

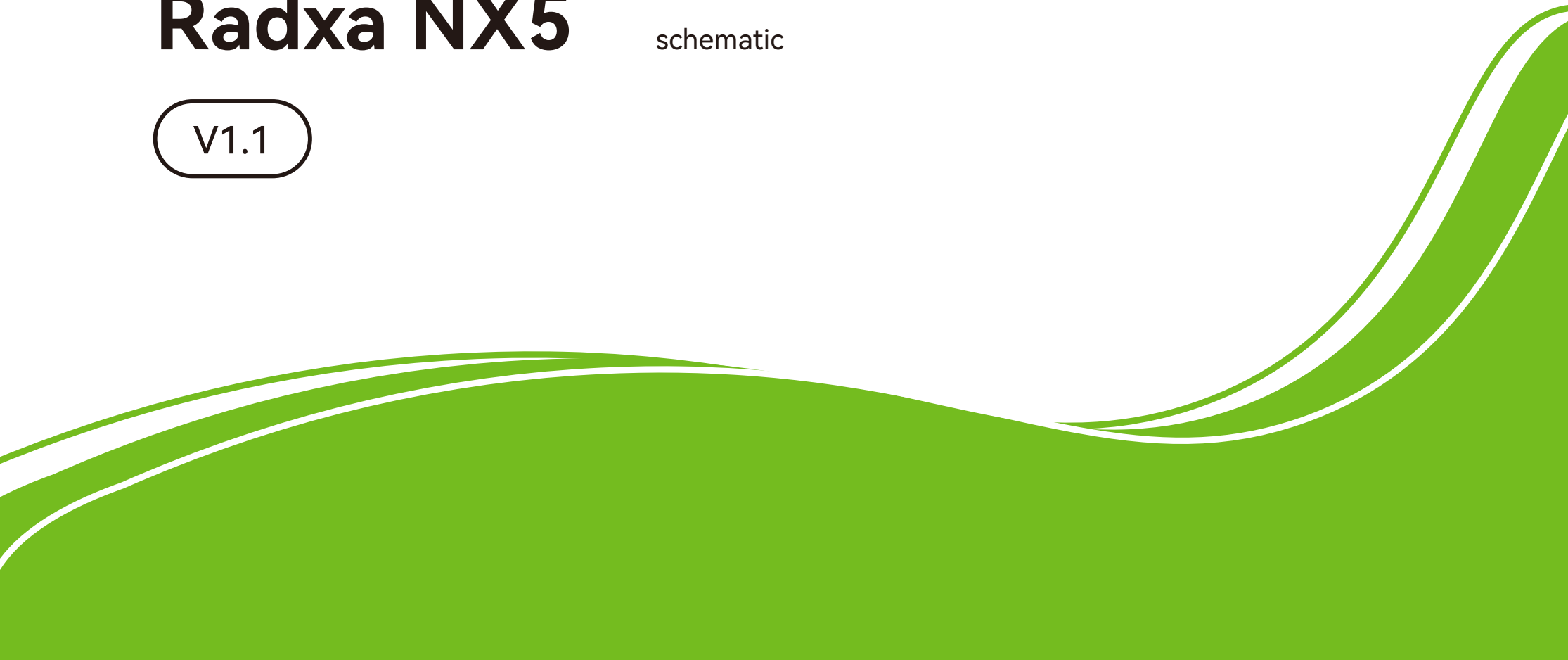

Radxa NX5

schematic

V1.1



CONTENT

- 01.Cover
- 02.Content
- 03.CONNECTOR
- 04.Ethernet-GEPHY RGMII1
- 05.Flash-SPI FLASH(opt)
- 06.eMMC Flash
- 07.Power-PMIC RK806-1
- 08.Power Ext Discrete
- 09.DRAM-LPDDR4/4X 200P 2X32bit
- 10.RK3588S Power/GND
- 11.RK3588S OSC/PLL/PMUIO
- 12.RK3588S DDR Controler
- 13.RK3588S Flash/SD Controller
- 14.RK3588S USB20/USB30/DP PHY
- 15.RK3588S SARADC/1.8V GPIO
- 16.RK3588S MIPI Interface
- 17.RK3588S HDMI/eDP Interface
- 18.RK3588S PCIE2/SATA3/USB3 PHY
- 19.RK3588S GPIO



Size	Title: Radxa NX5	REV
A4	Page Name: Content	1.1
Date: Thursday, October 19, 2023	Sheet 2	of 19

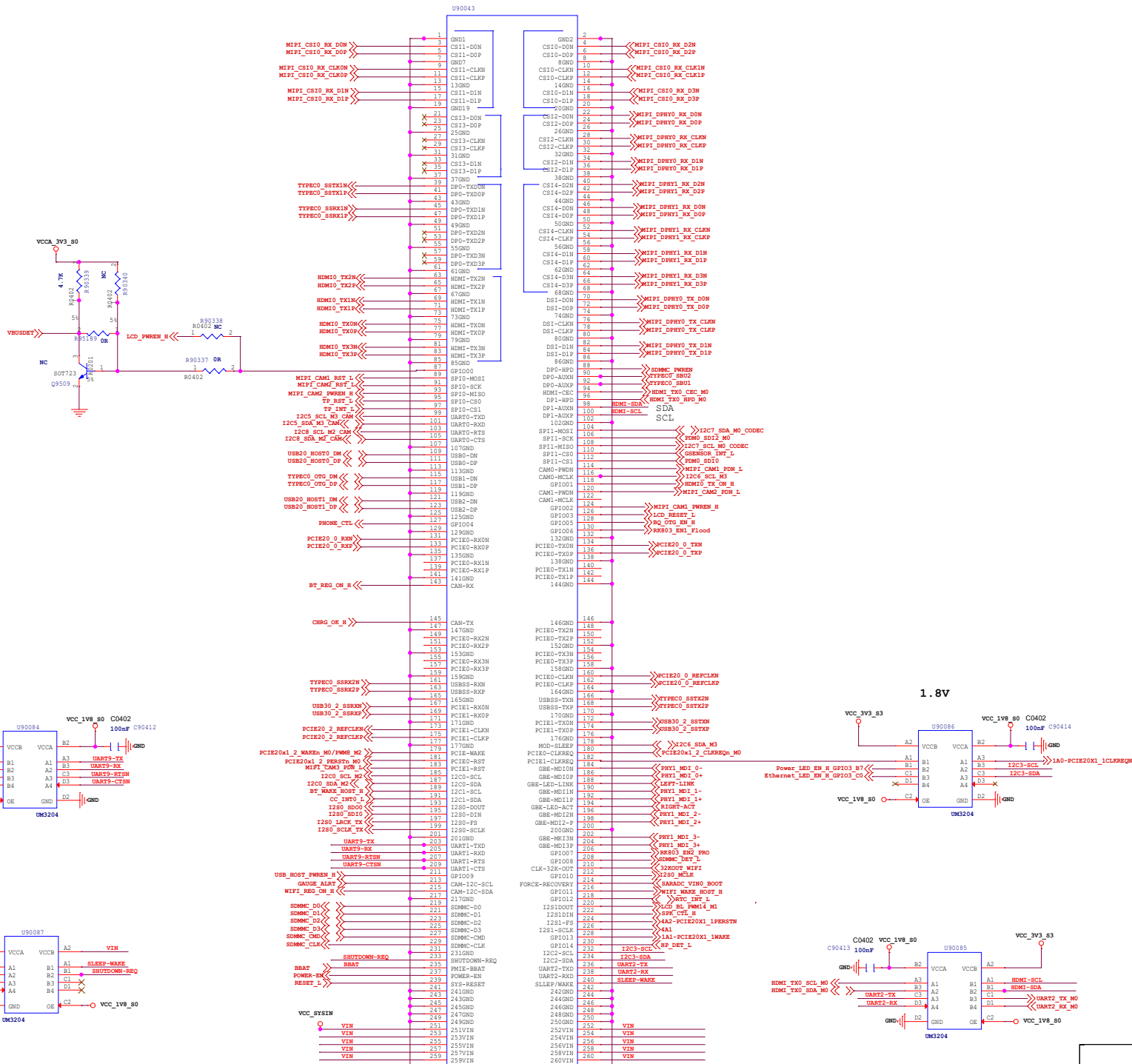

radxa

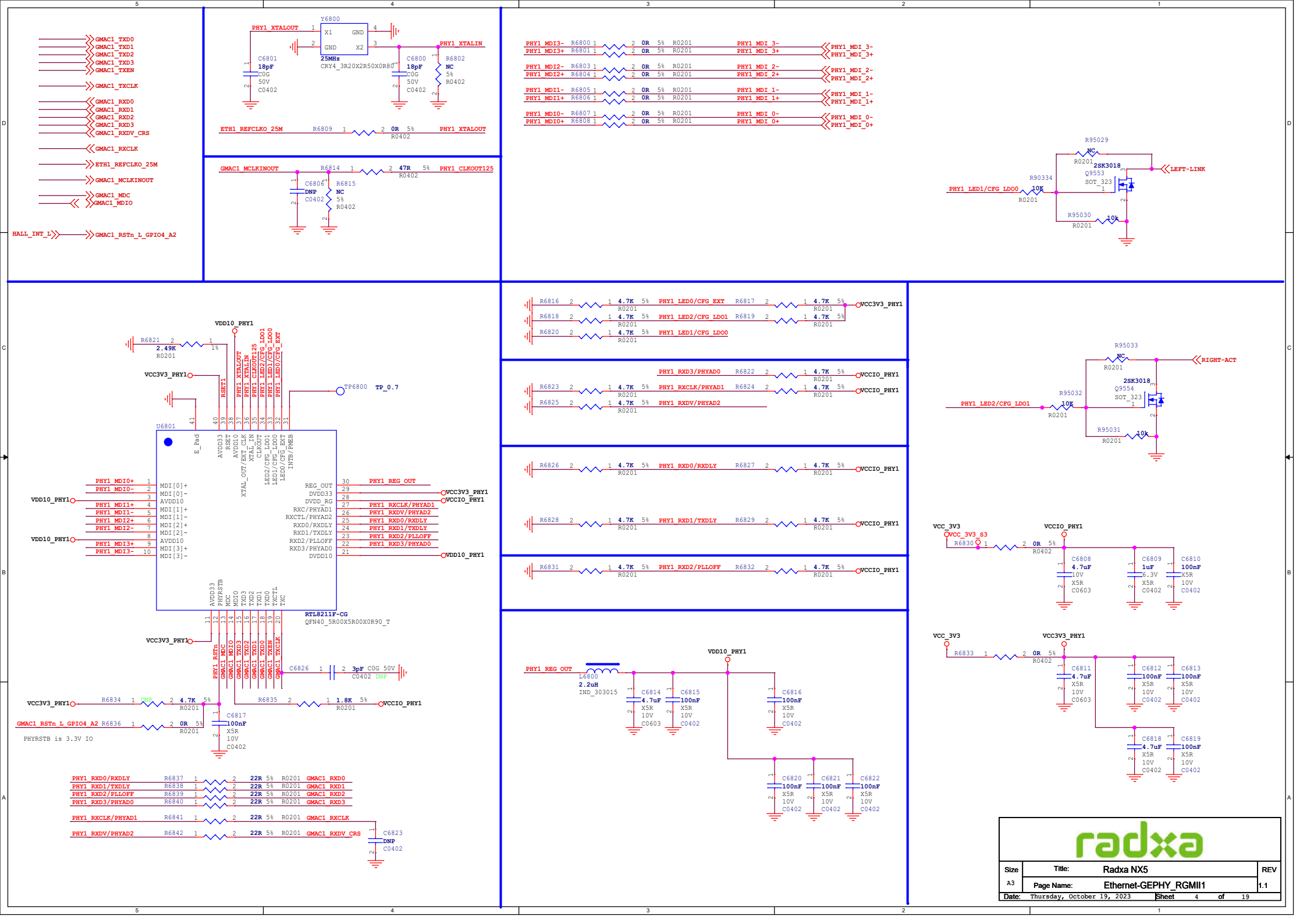

Size	Title: Radxa NX5	REV
C	Page Name: CONNECTOR	1.1
	Date: Thursday, October 19, 2023	Sheet 3 of 19



radxa

Size	Title	REV
A3	Radxa NX5	1.1
Date:	Page Name:	Sheet
Thursday, October 19, 2023	Ethernet-GEPHY_RGMII1	4 of 19

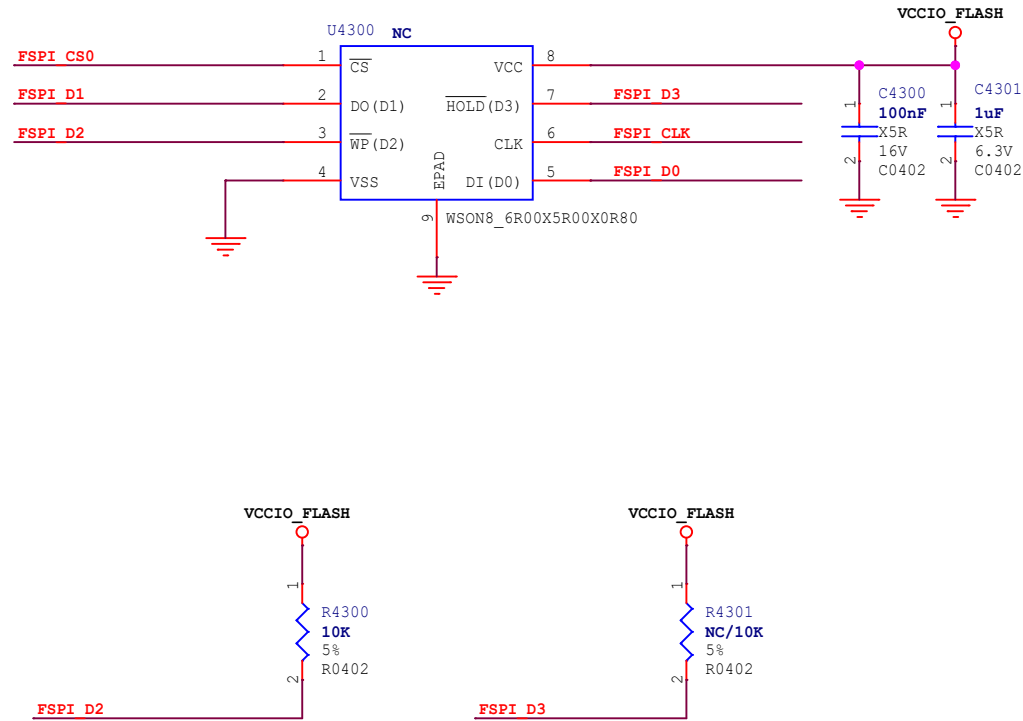
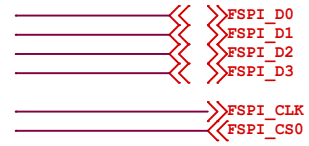
SPI FLASH



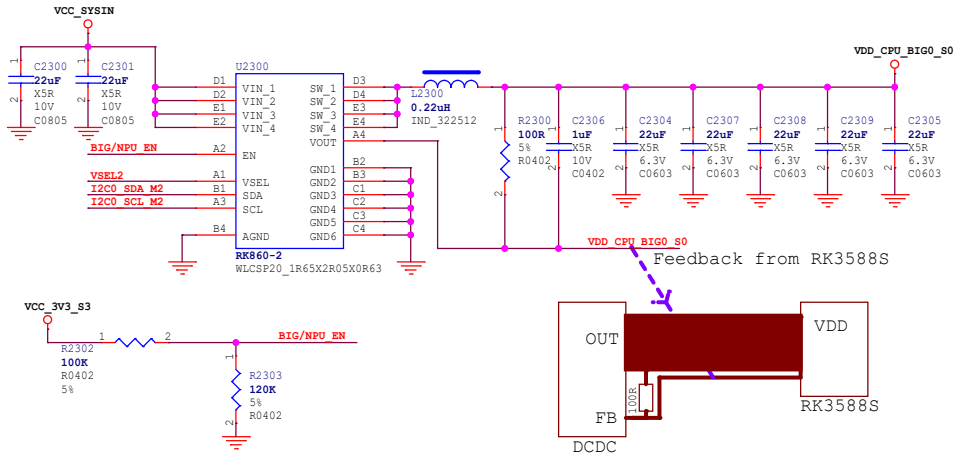

Size	Title: Radxa NX5	REV
A4	Page Name: Flash-SPI FLASH(opt)	1.1
Date: Thursday, October 19, 2023	Sheet 5 of 19	

VDD_CPU_BIG0

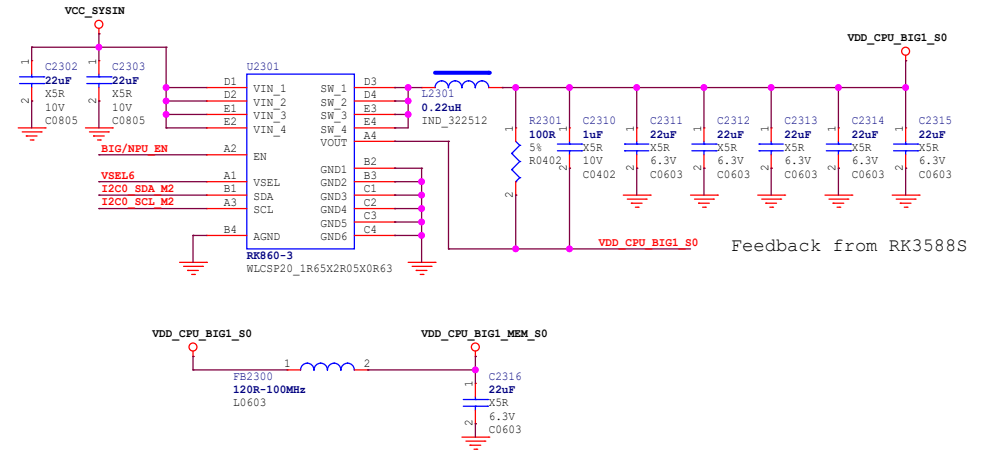

VDD_CPU_BIG1



VDD_NPU

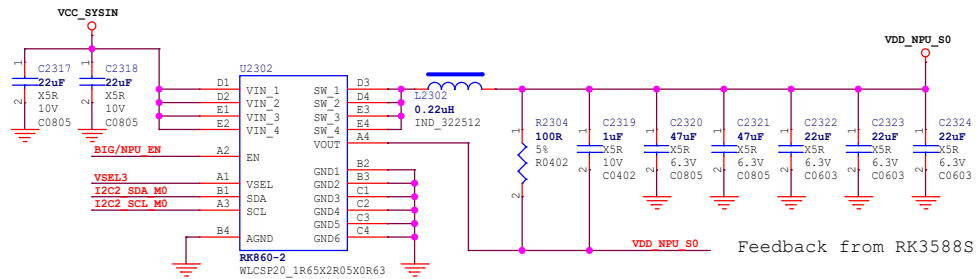

VCC_1V1_NLDO

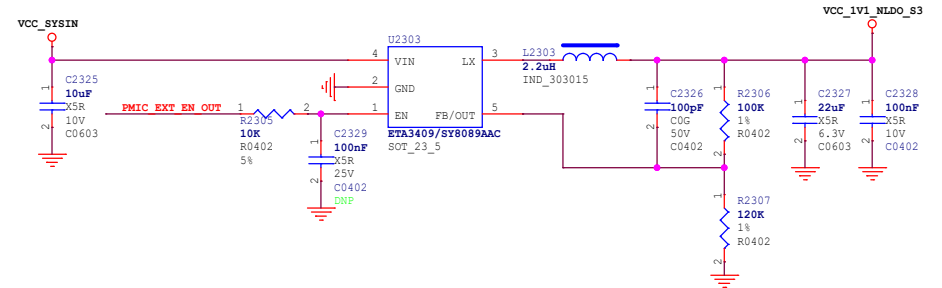

VCC_3V3_S0

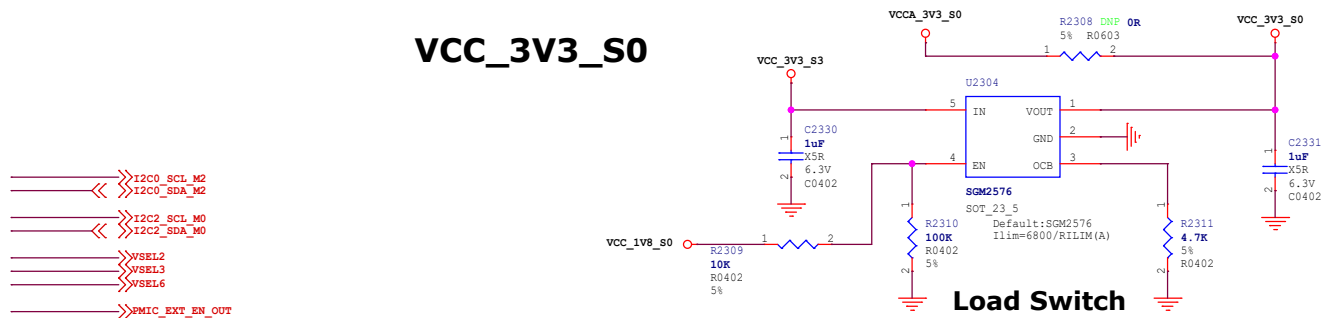

radxa

Size	Title: Radxa NX5	REV
A3	Page Name: Power_Ext Discrete	1.1
Date: Thursday, October 19, 2023	Sheet 8 of 19	

RK3588S (OSC/PLL/PMUIO1)

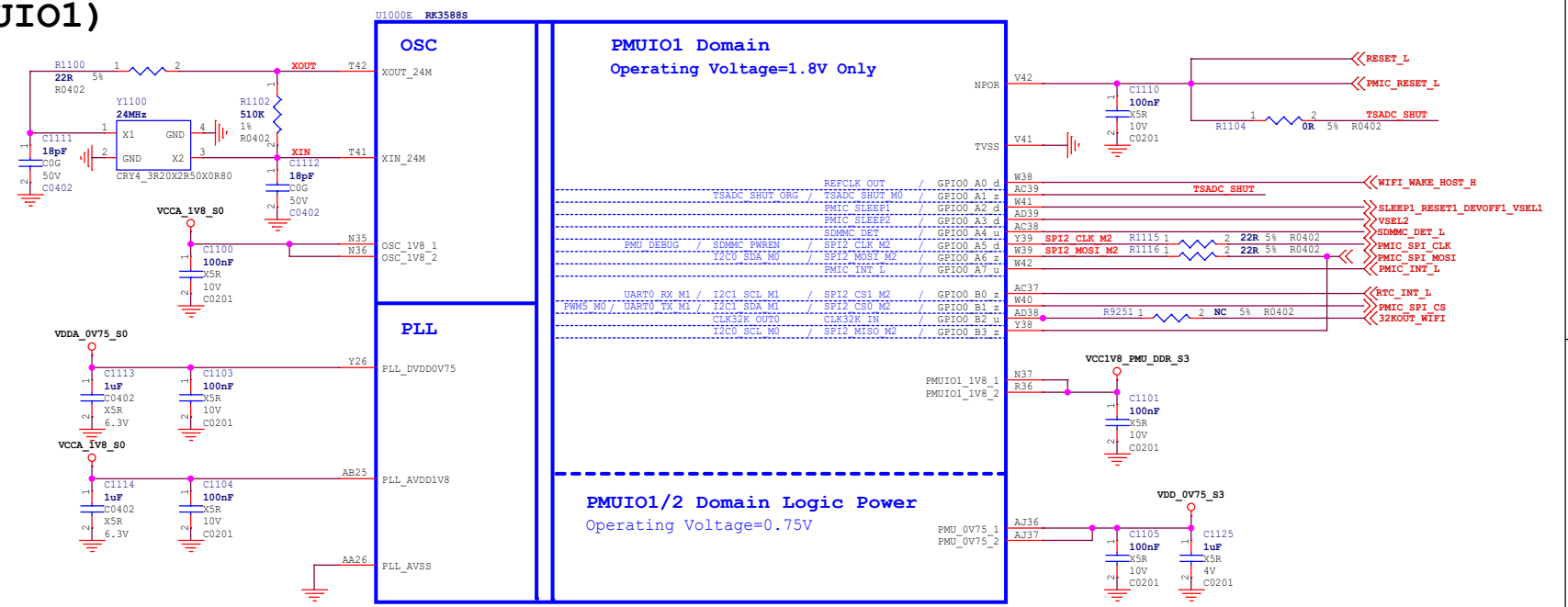

RK3588S (PMUIO2)

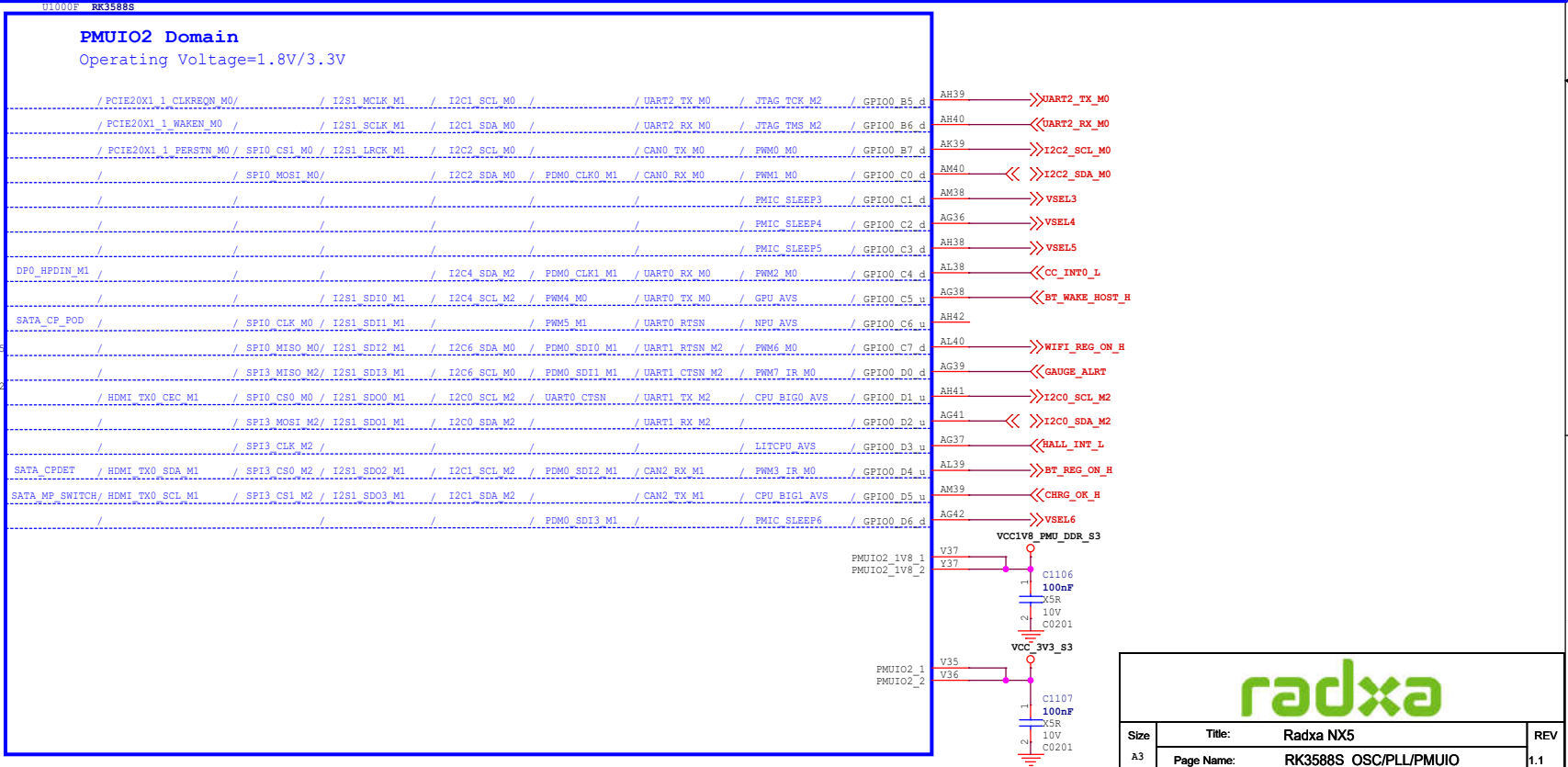
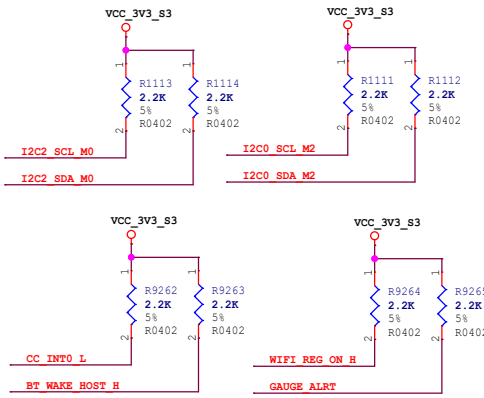



Size	Title: Radxa NX5	REV
A3	Page Name: RK3588S_OSC/PLL/PMUIO	1.1
Date:	Thursday, October 19, 2023	Sheet 11 of 19

RK3588S (EMMCIO Domain)

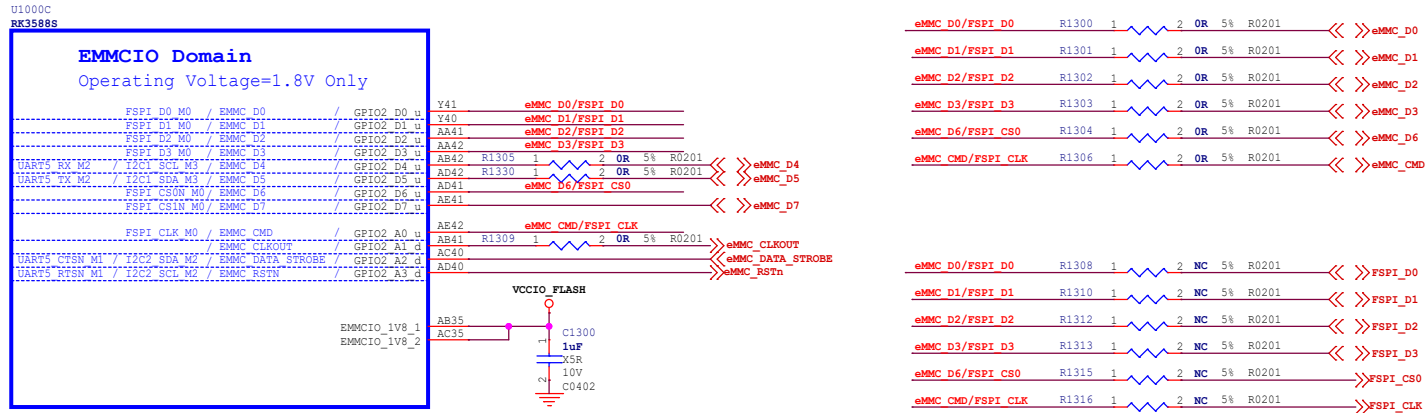

RK3588S (VCCIO2 Domain)

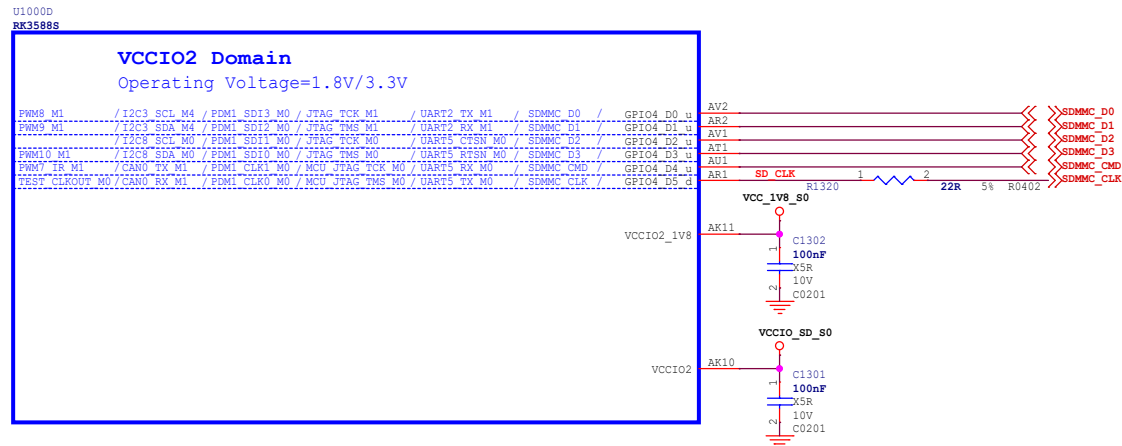

RK3588S (USB3.0/DP1.4)

U1000L RK3588S

USB 3.0 OTG of TYPECO /DP1.4 ALT

USB:U3/Gen1
DP:RBR/HBR/HBR2/HBR3

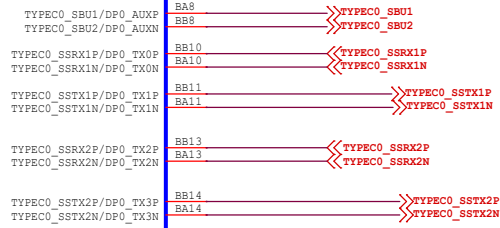

POWER

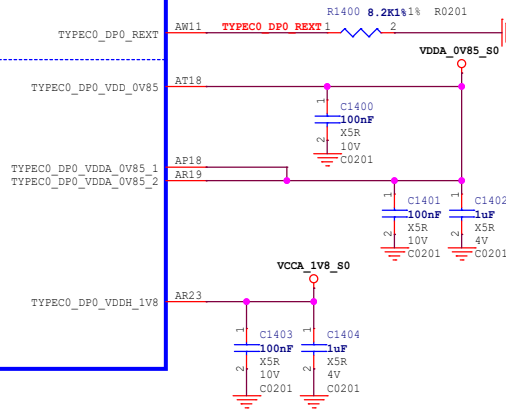

RK3588S (USB2.0)

U1000K RK3588S

USB2.0 OTG of TYPECO

HS/FS/LS
Download Port

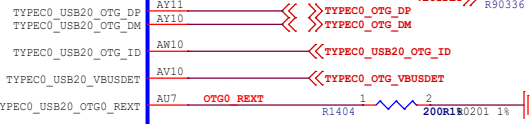

USB2.0 HOST0

HS/FS/LS



USB2.0 HOST1

HS/FS/LS

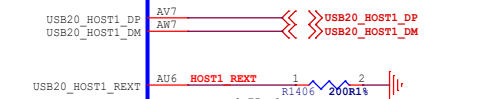

USB2.0 POWER

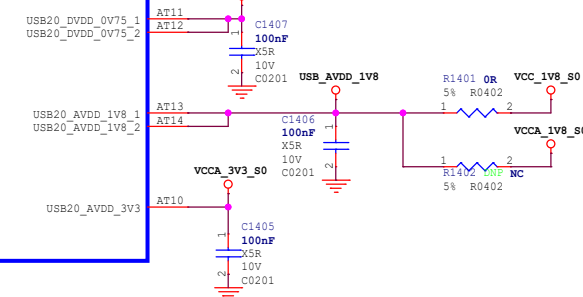

RK3588S (SARADC/OTP/TSADC)

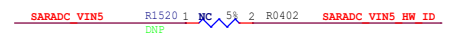
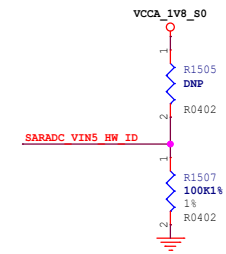
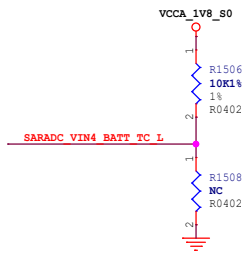
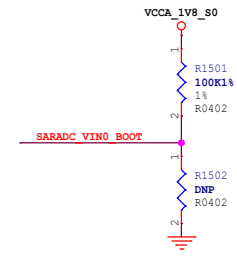
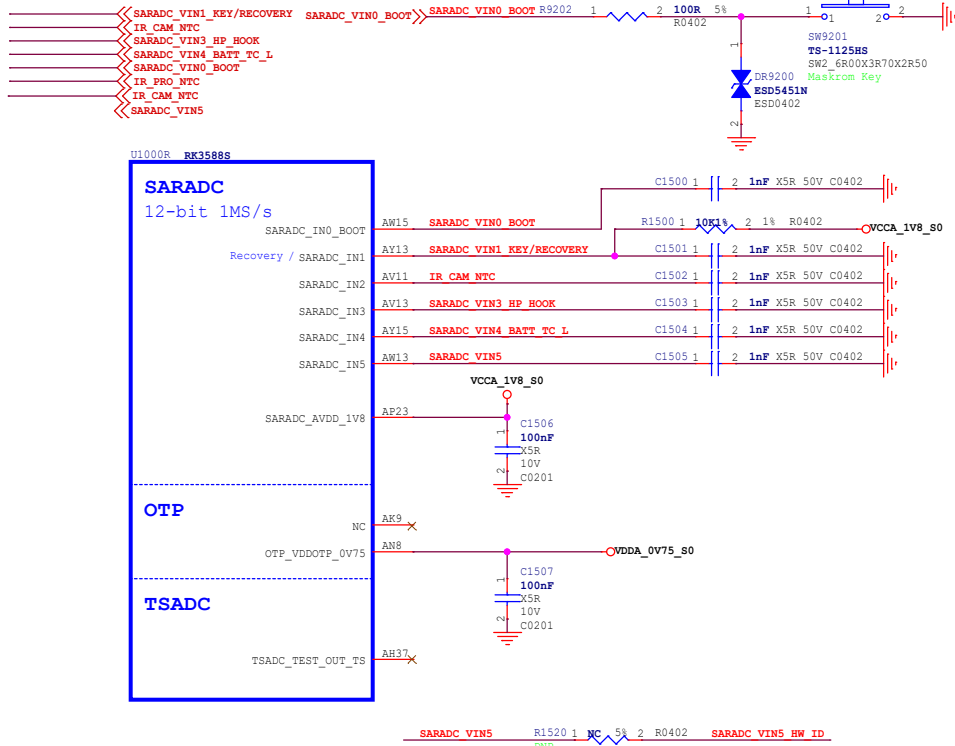

RK3588S (VCCIO1 Domain)

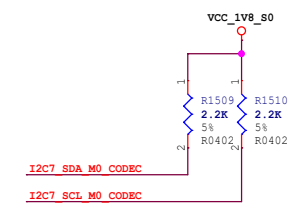
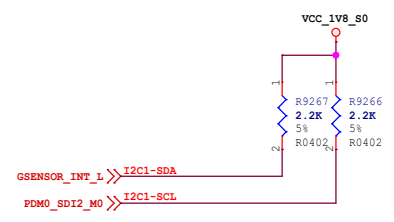
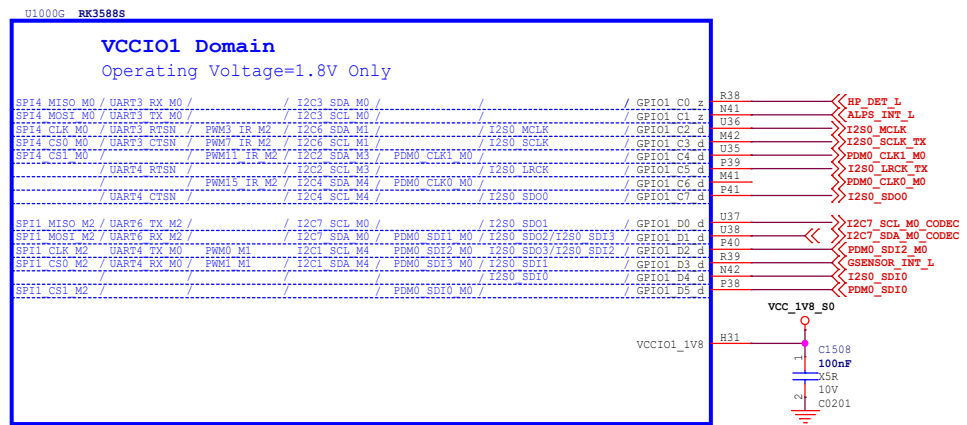

Size	Title: Radxa NX5	REV
A3	Page Name: RK3588S_SARADC/1.8V GPIO	1.1
Date: Thursday, October 19, 2023	Sheet 15 of 19	

RK3588S (HDMI2.1 TX/eDP1.3 TX)

U10000

HDMI TX/eDP1.3 MUX Port0

HDMI:V2.1 12Gbps
eDP: V1.3 5.4Gbps

HDMI_TX0_D0P/EDP_TX0_D0P BB4 EDP TX0 D0P/HDMI0 TX0P
HDMI_TX0_D0N/EDP_TX0_D0N BA4 EDP TX0 D0N/HDMI0 TX0N

HDMI_TX0_D1P/EDP_TX0_D1P BA5 EDP TX0 D1P/HDMI0 TX1P
HDMI_TX0_D1N/EDP_TX0_D1N BB5 EDP TX0 D1N/HDMI0 TX1N

HDMI_TX0_D2P/EDP_TX0_D2P BB7 EDP TX0 D2P/HDMI0 TX2P
HDMI_TX0_D2N/EDP_TX0_D2N BA7 EDP TX0 D2N/HDMI0 TX2N

HDMI_TX0_D3P/EDP_TX0_D3P BA2 EDP TX0 D3P/HDMI0 TX3P
HDMI_TX0_D3N/EDP_TX0_D3N BB2 EDP TX0 D3N/HDMI0 TX3N

HDMI_TX0_SBDP/EDP_TX0_AUXP BA1
HDMI_TX0_SBDN/EDP_TX0_AUXN AY1

Option1:eDP_TX0

EDP TX0 D0P/HDMI0 TX0P EDP TX0 D0P/HDMI0 TX0P >> EDP_TX0_D0P
EDP TX0 D0N/HDMI0 TX0N EDP TX0 D0N/HDMI0 TX0N >> EDP_TX0_D0N

EDP TX0 D1P/HDMI0 TX1P EDP TX0 D1P/HDMI0 TX1P >> EDP_TX0_D1P
EDP TX0 D1N/HDMI0 TX1N EDP TX0 D1N/HDMI0 TX1N >> EDP_TX0_D1N

EDP TX0 D2P/HDMI0 TX2P EDP TX0 D2P/HDMI0 TX2P >> EDP_TX0_D2P
EDP TX0 D2N/HDMI0 TX2N EDP TX0 D2N/HDMI0 TX2N >> EDP_TX0_D2N

EDP TX0 D3P/HDMI0 TX3P EDP TX0 D3P/HDMI0 TX3P >> EDP_TX0_D3P
EDP TX0 D3N/HDMI0 TX3N EDP TX0 D3N/HDMI0 TX3N >> EDP_TX0_D3N

EDP TX0 AUXP/HDMI0 TX_SBDP EDP TX0 AUXP >> EDP_TX0_AUXP
EDP TX0 AUXN/HDMI0 TX_SBDN EDP TX0 AUXN >> EDP_TX0_AUXN

Option2:HDMI_TX0

EDP TX0 D0P/HDMI0 TX0P >> HDMI0_TX0P
EDP TX0 D0N/HDMI0 TX0N >> HDMI0_TX0N

EDP TX0 D1P/HDMI0 TX1P >> HDMI0_TX1P
EDP TX0 D1N/HDMI0 TX1N >> HDMI0_TX1N

EDP TX0 D2P/HDMI0 TX2P >> HDMI0_TX2P
EDP TX0 D2N/HDMI0 TX2N >> HDMI0_TX2N

EDP TX0 D3P/HDMI0 TX3P >> HDMI0_TX3P
EDP TX0 D3N/HDMI0 TX3N >> HDMI0_TX3N

EDP TX0 AUXP/HDMI0 TX_SBDP >> HDMI0_TX_SBDP
EDP TX0 AUXN/HDMI0 TX_SBDN >> HDMI0_TX_SBDN

HDMI/eDP_TX0_REXT AY3 HDMI/eDP TX0_REXT R1708 1 8.2K 1% R0201 VDDA_0V75_S0

POWER

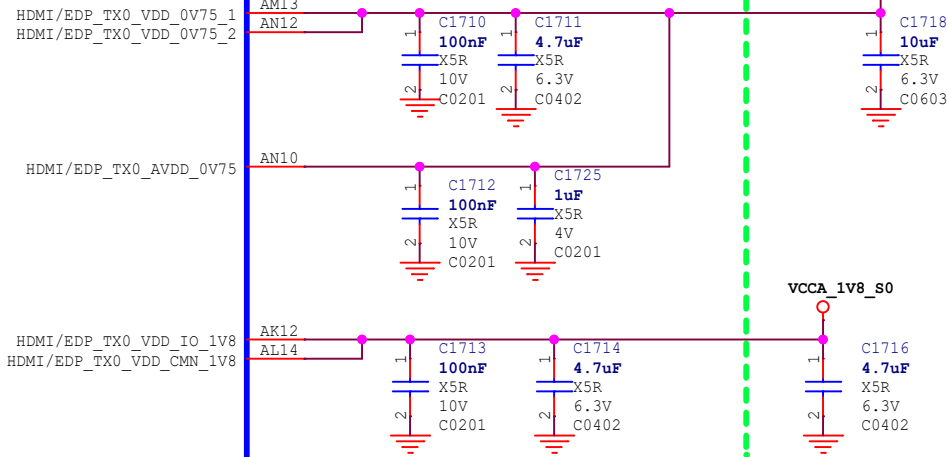

RK3588S



Size	Title: Radxa NX5	REV
A4	Page Name: RK3588S_HDMI/eDP Interface	1.1
Date: Thursday, October 19, 2023	Sheet 17 of 19	

RK3588S (PCIE20/SATA30/USB30)

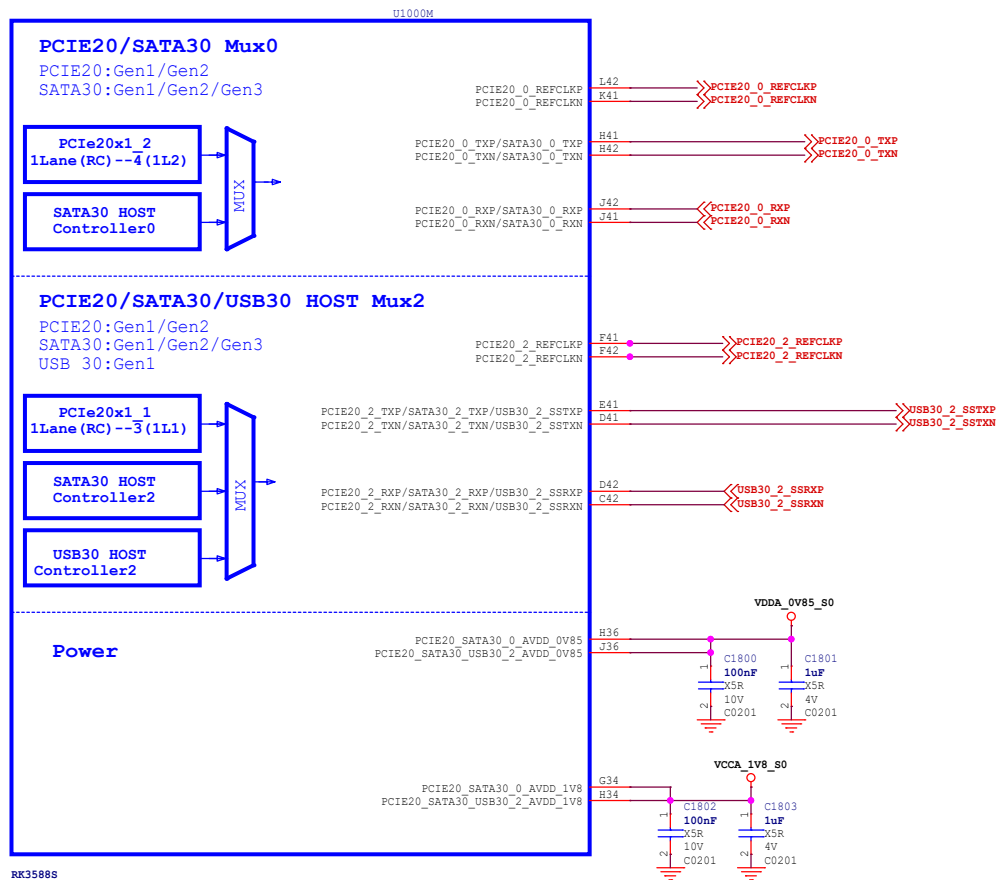

RK3588S

