

FCC Test Report

Report No.: RFBBUI-WTW-P21040655

FCC ID: TX2-RTL8852BE

Test Model: RTL8852BE

Received Date: Apr. 21, 2021

Test Date: May 05 to July 08, 2021

Issued Date: Aug. 02, 2021

Applicant: Realtek Semiconductor Corp.

Address: No. 2, Innovation Road II, Hsinchu Science Park, Hsinchu 300, Taiwan

Issued By: Bureau Veritas Consumer Products Services (H.K.) Ltd., Taoyuan Branch
Hsin Chu Laboratory

Lab Address: E-2, No.1, Li Hsin 1st Road, Hsinchu Science Park, Hsinchu City 300,
Taiwan

Test Location : E-2, No.1, Li Hsin 1st Road, Hsinchu Science Park, Hsinchu City 300,
Taiwan

**FCC Registration /
Designation Number:** 723255 / TW2022



This report is for your exclusive use. Any copying or replication of this report to or for any other person or entity, or use of our name or trademark, is permitted only with our prior written permission. This report sets forth our findings solely with respect to the test samples identified herein. The results set forth in this report are not indicative or representative of the quality or characteristics of the lot from which a test sample was taken or any similar or identical product unless specifically and expressly noted. Our report includes all of the tests requested by you and the results thereof based upon the information that you provided to us. You have 60 days from date of issuance of this report to notify us of any material error or omission caused by our negligence, provided, however, that such notice shall be in writing and shall specifically address the issue you wish to raise. A failure to raise such issue within the prescribed time shall constitute your unqualified acceptance of the completeness of this report, the tests conducted and the correctness of the report contents. Unless specific mention, the uncertainty of measurement has been explicitly taken into account to declare the compliance or non-compliance to the specification.

Table of Contents

Release Control Record	4
1 Certificate of Conformity	5
2 Summary of Test Results	6
2.1 Measurement Uncertainty.....	6
2.2 Modification Record.....	6
3 General Information	7
3.1 General Description of EUT.....	7
3.2 Description of Test Modes.....	10
3.2.1 Test Mode Applicability and Tested Channel Detail.....	11
3.3 Duty Cycle of Test Signal.....	14
3.4 Description of Support Units.....	18
3.4.1 Configuration of System under Test.....	19
3.5 General Description of Applied Standards and references.....	20
4 Test Types and Results	21
4.1 Radiated Emission and Bandedge Measurement.....	21
4.1.1 Limits of Radiated Emission and Bandedge Measurement.....	21
4.1.2 Test Instruments.....	22
4.1.3 Test Procedures.....	25
4.1.4 Deviation from Test Standard.....	25
4.1.5 Test Setup.....	26
4.1.6 EUT Operating Conditions.....	27
4.1.7 Test Results (Mode 1).....	28
4.1.8 Test Results (Mode 2).....	102
4.2 Conducted Emission Measurement.....	176
4.2.1 Limits of Conducted Emission Measurement.....	176
4.2.2 Test Instruments.....	176
4.2.3 Test Procedures.....	177
4.2.4 Deviation from Test Standard.....	177
4.2.5 Test Setup.....	177
4.2.6 EUT Operating Conditions.....	177
4.2.7 Test Results.....	178
4.3 6dB Bandwidth Measurement.....	180
4.3.1 Limits of 6dB Bandwidth Measurement.....	180
4.3.2 Test Setup.....	180
4.3.3 Test Instruments.....	180
4.3.4 Test Procedure.....	180
4.3.5 Deviation from Test Standard.....	180
4.3.6 EUT Operating Conditions.....	180
4.3.7 Test Result (Mode 1).....	181
4.3.8 Test Result (Mode 2).....	184
4.4 Conducted Output Power Measurement.....	187
4.4.1 Limits of Conducted Output Power Measurement.....	187
4.4.2 Test Setup.....	187
4.4.3 Test Instruments.....	187
4.4.4 Test Procedures.....	187
4.4.5 Deviation from Test Standard.....	187
4.4.6 EUT Operating Conditions.....	187
4.4.7 Test Results (Mode 1).....	188
4.4.8 Test Results (Mode 2).....	193
4.5 Power Spectral Density Measurement.....	196
4.5.1 Limits of Power Spectral Density Measurement.....	196
4.5.2 Test Setup.....	196
4.5.3 Test Instruments.....	196

4.5.4	Test Procedure	196
4.5.5	Deviation from Test Standard	196
4.5.6	EUT Operating Condition	196
4.5.7	Test Results (Mode 1).....	197
4.5.8	Test Results (Mode 2).....	202
4.6	Conducted Out of Band Emission Measurement.....	205
4.6.1	Limits of Conducted Out of Band Emission Measurement	205
4.6.2	Test Setup.....	205
4.6.3	Test Instruments	205
4.6.4	Test Procedure	205
4.6.5	Deviation from Test Standard	205
4.6.6	EUT Operating Condition	205
4.6.7	Test Results	205
5	Pictures of Test Arrangements.....	248
	Annex A - Band-Edge Measurement.....	249
	Annex A.1 - Test Results (Mode 1).....	249
	Annex A.2 - Test Results (Mode 2).....	277
	Appendix – Information of the Testing Laboratories	305

Release Control Record

Issue No.	Description	Date Issued
RFBUI-WTW-P21040655	Original release.	Aug. 02, 2021

1 Certificate of Conformity

Product: 11ax RTL8852BE Combo module

Brand: REALTEK

Test Model: RTL8852BE

Sample Status: Engineering sample

Applicant: Realtek Semiconductor Corp.

Test Date: May 05 to July 08, 2021

Standards: 47 CFR FCC Part 15, Subpart C (Section 15.247)
ANSI C63.10: 2013

The above equipment has been tested by **Bureau Veritas Consumer Products Services (H.K.) Ltd., Taoyuan Branch**, and found compliance with the requirement of the above standards. The test record, data evaluation & Equipment Under Test (EUT) configurations represented herein are true and accurate accounts of the measurements of the sample's EMC characteristics under the conditions specified in this report.

Prepared by : Cherry Chuo, **Date:** Aug. 02, 2021
Cherry Chuo / Specialist

Approved by : Clark Lin, **Date:** Aug. 02, 2021
Clark Lin / Technical Manager

2 Summary of Test Results

47 CFR FCC Part 15, Subpart C (Section 15.247)			
FCC Clause	Test Item	Result	Remarks
15.207	AC Power Conducted Emission	PASS	Meet the requirement of limit. Minimum passing margin is -14.65dB at 25.875 MHz.
15.205 / 15.209 / 15.247(d)	Radiated Emissions and Band Edge Measurement	PASS	Meet the requirement of limit. Minimum passing margin is -1.5 dB at 2488.00 MHz, 2484.60 MHz, 2483.50 MHz, 2388.26 MHz, 2388.17 MHz, 2484.74 MHz, 2485.36 MHz, 2483.85 MHz, 2388.78 MHz, 2483.90 MHz and 2389.62 MHz
15.247(d)	Antenna Port Emission	PASS	Meet the requirement of limit.
15.247(a)(2)	6dB bandwidth	PASS	Meet the requirement of limit.
15.247(b)	Conducted power	PASS	Meet the requirement of limit.
15.247(e)	Power Spectral Density	PASS	Meet the requirement of limit.
15.203	Antenna Requirement	PASS	Antenna connector is i-pex(MHF) not a standard connector.

Note:

- For 2.4GHz band compliance with rule 15.247(d) of the band-edge items, the test plots were recorded in Annex A. Test Procedures refer to report 4.1.3.
- Determining compliance based on the results of the compliance measurement, not taking into account measurement instrumentation uncertainty.

2.1 Measurement Uncertainty

Where relevant, the following measurement uncertainty levels have been estimated for tests performed on the EUT as specified in CISPR 16-4-2:

Measurement	Frequency	Expanded Uncertainty (k=2) (±)
Conducted Emissions at mains ports	150kHz ~ 30MHz	1.9 dB
Conducted emissions	-	2.5 dB
Radiated Emissions up to 1 GHz	9kHz ~ 30MHz	3.1 dB
	30MHz ~ 1GHz	5.1 dB
Radiated Emissions above 1 GHz	1GHz ~ 18GHz	5.1 dB
	18GHz ~ 40GHz	5.3 dB

2.2 Modification Record

There were no modifications required for compliance.

3 General Information

3.1 General Description of EUT

Product	11ax RTL8852BE Combo module
Brand	REALTEK
Test Model	RTL8852BE
Status of EUT	Engineering sample
Power Supply Rating	3.3Vdc from host equipment
Modulation Type	CCK, DQPSK, DBPSK for DSSS 64QAM, 16QAM, QPSK, BPSK for OFDM 256QAM for OFDM in 11ac mode and VHT (20/40) mode in 2.4GHz 1024QAM for OFDMA in 11ax HE mode
Modulation Technology	DSSS, OFDM, OFDMA
Transfer Rate	802.11b: up to 11 Mbps 802.11a/g: up to 54 Mbps 802.11n: up to 300 Mbps 802.11ac: up to 866.7 Mbps 802.11ax: up to 1201 Mbps
Operating Frequency	2.4GHz: 2.412 ~ 2.472 GHz 5GHz: 5.18 ~ 5.24 GHz, 5.26 ~ 5.32 GHz, 5.50 ~ 5.72 GHz, 5.745 ~ 5.825 GHz
Number of Channel	2.4GHz: 802.11b, 802.11g, 802.11n (HT20), VHT20, 802.11ax (HE20): 13, 802.11n (HT40), VHT40, 802.11ax (HE40): 9 5GHz: 802.11a, 802.11n (HT20), 802.11ac (VHT20), 802.11ax (HE20): 25 802.11n (HT40), 802.11ac (VHT40), 802.11ax (HE40): 12 802.11ac (VHT80), 802.11ax (HE80): 6
Output Power	For 2TX CDD Mode: 2.4 GHz: 307.683 mW 5.18 ~ 5.24 GHz: 247.192 mW 5.26 ~ 5.32 GHz: 248.568 mW 5.5 ~ 5.72 GHz: 244.863 mW 5.745 ~ 5.825 GHz: 348 mW Beamforming Mode: 2.4 GHz: 304.343 mW 5.18 ~ 5.24 GHz: 156.619 mW 5.26 ~ 5.32 GHz: 156.367 mW 5.5 ~ 5.72 GHz: 156.336 mW 5.745 ~ 5.825 GHz: 320.286 mW For 1TX 2.4 GHz: 175.792 mW 5.18 ~ 5.24 GHz: 172.187 mW 5.26 ~ 5.32 GHz: 173.38 mW 5.5 ~ 5.72 GHz: 171.791 mW 5.745 ~ 5.825 GHz: 176.604 mW
Antenna Type	Refer to Note
Antenna Connector	Refer to Note
Accessory Device	NA
Data Cable Supplied	NA

Note:

1. The EUT has below HW SKU configuration, as below table:

SKU No.	Interface	Description
1	PCIe + USB	Single antenna port
2	PCIe + USB	Dual antenna port
3	PCIe + UART	Dual antenna port

Note: From the above HW SKUs, for conducted emission & radiated below 1GHz the worse case was found in **SKU No.: 3** and other test items the worse case was found in **SKU No.: 2**. Therefore only the test data of the SKU was recorded in this report.

2. Simultaneously transmission condition.

Condition	Technology	
1	WLAN 5GHz	Bluetooth

Note: The emission of the simultaneous operation has been evaluated and no non-compliance was found.

3. The antennas provided to the EUT, please refer to the following table:

Ant. Set	RF Chain No.	Brand	Model	Ant. Net Gain (dBi)	Frequency Range (GHz)	Ant. Type	Connector Type	Cable Length (mm)
1	Chain 0	ARISTOTLE	RFA-27-JP326-MHF4300	3.5	2.4~2.4835	PIFA	i-pex(MHF)	300
				5	5.15~5.85			
				5	5.875~7.125			
	Chain 1	ARISTOTLE	RFA-27-JP326-MHF4300	3.5	2.4~2.4835	PIFA	i-pex(MHF)	300
				5	5.15~5.85			
				5	5.875~7.125			
2	Chain 0	ARISTOTLE	RFA-27-C38H1-MHF4300	3	2.4~2.4835	Dipole	i-pex(MHF)	300
				5	5.15~5.85			
				5	5.875~7.125			
	Chain 1	ARISTOTLE	RFA-27-C38H1-MHF4300	3	2.4~2.4835	Dipole	i-pex(MHF)	300
				5	5.15~5.85			
				5	5.875~7.125			

Note:

- From the above transmission chains, the worse case was found in transmission on Chain 0 for 1TX mode. Therefore only the test data of the mode was recorded in this report.
- The Bluetooth technology will fix transmission on Chain 1.
- Max. gain was selected for the final test, except for the radiated emissions test.

4. The EUT incorporates a MIMO function:

2.4GHz Band		
MODULATION MODE	TX & RX CONFIGURATION	
802.11b	2TX/1TX Diversity	2RX
802.11g	2TX/1TX Diversity	2RX
802.11n (HT20)	2TX/1TX Diversity	2RX
802.11n (HT40)	2TX/1TX Diversity	2RX
VHT20	2TX/1TX Diversity	2RX
VHT40	2TX/1TX Diversity	2RX
802.11ax (HE20)	2TX/1TX Diversity	2RX
802.11ax (HE40)	2TX/1TX Diversity	2RX
802.11ax (RU26/52/106/242/484)	2TX/1TX Diversity	2RX
5GHz Band		
MODULATION MODE	TX & RX CONFIGURATION	
802.11a	2TX/1TX Diversity	2RX
802.11n (HT20)	2TX/1TX Diversity	2RX
802.11n (HT40)	2TX/1TX Diversity	2RX
802.11ac (VHT20)	2TX/1TX Diversity	2RX
802.11ac (VHT40)	2TX/1TX Diversity	2RX
802.11ac (VHT80)	2TX/1TX Diversity	2RX
802.11ax (HE20)	2TX/1TX Diversity	2RX
802.11ax (HE40)	2TX/1TX Diversity	2RX
802.11ax (HE80)	2TX/1TX Diversity	2RX
802.11ax (RU26/52/106/242/484/996)	2TX/1TX Diversity	2RX

Note:

1. All of modulation mode support beamforming function except 802.11a/b/g modulation mode.
2. The EUT support Beamforming and CDD mode, therefore both mode were investigated and the worst case scenario was identified. The worst case data were presented in test report.
3. The modulation and bandwidth are similar for 802.11n mode for 20MHz (40MHz), VHT mode for 20MHz (40MHz) and 802.11ax mode for 20MHz (40MHz), therefore the manufacturer will control the power for 802.11n mode as same as the VHT mode and ax mode or more lower than it and investigated worst case to representative mode in test report. (Final test mode refer to section 3.2.1)

5. The above EUT information is declared by manufacturer and for more detailed features description, please refer to the manufacturer's specifications or User's Manual.
6. The above Antenna information is declared by manufacturer and for more detailed features description, please refer to the manufacturer's specifications, the laboratory shall not be held responsible.

3.2 Description of Test Modes

13 channels are provided for 802.11b, 802.11g, 802.11n (HT20), VHT20 and 802.11ax (HE20):

Channel	Frequency	Channel	Frequency
1	2412MHz	8	2447MHz
2	2417MHz	9	2452MHz
3	2422MHz	10	2457MHz
4	2427MHz	11	2462MHz
5	2432MHz	12	2467MHz
6	2437MHz	13	2472MHz
7	2442MHz		

9 channels are provided for 802.11n (HT40), VHT40 and 802.11ax (HE40):

Channel	Frequency	Channel	Frequency
3	2422MHz	8	2447MHz
4	2427MHz	9	2452MHz
5	2432MHz	10	2457MHz
6	2437MHz	11	2462MHz
7	2442MHz		

3.2.1 Test Mode Applicability and Tested Channel Detail

EUT CONFIGURE MODE	APPLICABLE TO				DESCRIPTION
	RE \geq 1G	RE $<$ 1G	PLC	APCM	
1	√	√	√	√	2TX
2	√	√	-	√	1TX

Where **RE \geq 1G**: Radiated Emission above 1GHz & Bandedge Measurement **RE $<$ 1G**: Radiated Emission below 1GHz

PLC: Power Line Conducted Emission **APCM**: Antenna Port Conducted Measurement

Note: 1. The EUT's PIFA antenna had been pre-tested on the positioned of each 3 axis. The worst case was found when positioned on **X-plane**.

2. For 20MHz bandwidth, 40MHz bandwidth and 80MHz bandwidth of RU mode, the worst case was found in 20MHz bandwidth. Therefore only the test data of the mode was recorded in this report.

Radiated Emission Test (Above 1GHz):

Pre-Scan has been conducted to determine the worst-case mode from all possible combinations between available modulations, data rates and antenna ports (if EUT with antenna diversity architecture).

Following channel(s) was (were) selected for the final test as listed below.

2TX (CDD Mode)						
MODE	AVAILABLE CHANNEL	TESTED CHANNEL	MODULATION TECHNOLOGY	MODULATION TYPE	Data Rate Parameter	RU Configuration
802.11b	1 to 13	1, 6, 11, 12, 13	DSSS	DBPSK	1Mb/s	-
802.11g	1 to 13	1, 6, 11, 12, 13	OFDM	BPSK	6Mb/s	-
802.11ax (HE20)	1 to 13	1, 6, 11, 12, 13	OFDMA	BPSK	MCS0	-
802.11ax (HE40)	3 to 11	3, 6, 9, 10, 11	OFDMA	BPSK	MCS0	-
802.11ax (RU26)	1 to 13	1, 6, 11, 12, 13	OFDMA	BPSK	MCS0	26/0, 26/4, 26/8, 26/8, 26/8
802.11ax (RU52)	1 to 13	1, 6, 11, 12, 13	OFDMA	BPSK	MCS0	52/37, 52/39, 52/40, 52/40, 52/40
802.11ax (RU106)	1 to 13	1, 6, 11, 12, 13	OFDMA	BPSK	MCS0	106/53, 106/54, 106/54, 106/54, 106/54
1TX						
MODE	AVAILABLE CHANNEL	TESTED CHANNEL	MODULATION TECHNOLOGY	MODULATION TYPE	Data Rate Parameter	RU Configuration
802.11b	1 to 13	1, 6, 11, 12, 13	DSSS	DBPSK	1Mb/s	-
802.11g	1 to 13	1, 6, 11, 12, 13	OFDM	BPSK	6Mb/s	-
802.11ax (HE20)	1 to 13	1, 6, 11, 12, 13	OFDMA	BPSK	MCS0	-
802.11ax (HE40)	3 to 11	3, 6, 9, 10, 11	OFDMA	BPSK	MCS0	-
802.11ax (RU26)	1 to 13	1, 6, 11, 12, 13	OFDMA	BPSK	MCS0	26/0, 26/4, 26/8, 26/8, 26/8
802.11ax (RU52)	1 to 13	1, 6, 11, 12, 13	OFDMA	BPSK	MCS0	52/37, 52/39, 52/40, 52/40, 52/40
802.11ax (RU106)	1 to 13	1, 6, 11, 12, 13	OFDMA	BPSK	MCS0	106/53, 106/54, 106/54, 106/54, 106/54

Radiated Emission Test (Below 1GHz):

- Pre-Scan has been conducted to determine the worst-case mode from all possible combinations between available modulations, data rates and antenna ports (if EUT with antenna diversity architecture).
- Following channel(s) was (were) selected for the final test as listed below.

1TX/2TX (CDD Mode)					
MODE	AVAILABLE CHANNEL	TESTED CHANNEL	MODULATION TECHNOLOGY	MODULATION TYPE	Data Rate Parameter
802.11g	1 to 13	6	OFDM	BPSK	6Mb/s

Power Line Conducted Emission Test:

- Pre-Scan has been conducted to determine the worst-case mode from all possible combinations between available modulations, data rates and antenna ports (if EUT with antenna diversity architecture).
- Following channel(s) was (were) selected for the final test as listed below.

2TX (CDD Mode)					
MODE	AVAILABLE CHANNEL	TESTED CHANNEL	MODULATION TECHNOLOGY	MODULATION TYPE	Data Rate Parameter
802.11g	1 to 13	6	OFDM	BPSK	6Mb/s

Antenna Port Conducted Measurement:

- This item includes all test value of each mode, but only includes spectrum plot of worst value of each mode.
- Pre-Scan has been conducted to determine the worst-case mode from all possible combinations between available modulations, data rates and antenna ports (if EUT with antenna diversity architecture).
- Following channel(s) was (were) selected for the final test as listed below.

2TX (CDD Mode)						
MODE	AVAILABLE CHANNEL	TESTED CHANNEL	MODULATION TECHNOLOGY	MODULATION TYPE	Data Rate Parameter	RU Configuration
802.11b	1 to 13	1, 6, 11, 12, 13	DSSS	DBPSK	1Mb/s	-
802.11g	1 to 13	1, 6, 11, 12, 13	OFDM	BPSK	6Mb/s	-
VHT20 (Output power only)	1 to 13	1, 6, 11, 12, 13	OFDM	BPSK	MCS0	-
VHT40 (Output power only)	3 to 11	3, 6, 9, 10, 11	OFDM	BPSK	MCS0	-
802.11ax (HE20)	1 to 13	1, 6, 11, 12, 13	OFDMA	BPSK	MCS0	-
802.11ax (HE40)	3 to 11	3, 6, 9, 10, 11	OFDMA	BPSK	MCS0	-
802.11ax (RU26)	1 to 13	1, 6, 11, 12, 13	OFDMA	BPSK	MCS0	26/0, 26/4, 26/8, 26/8, 26/8
802.11ax (RU52)	1 to 13	1, 6, 11, 12, 13	OFDMA	BPSK	MCS0	52/37, 52/39, 52/40, 52/40, 52/40
802.11ax (RU106)	1 to 13	1, 6, 11, 12, 13	OFDMA	BPSK	MCS0	106/53, 106/54, 106/54, 106/54, 106/54

2TX (Beamforming Mode) (output power only)

MODE	AVAILABLE CHANNEL	TESTED CHANNEL	MODULATION TECHNOLOGY	MODULATION TYPE	Data Rate Parameter
VHT20	1 to 13	1, 6, 11, 12, 13	OFDM	BPSK	MCS0
VHT40	3 to 11	3, 6, 9, 10, 11	OFDM	BPSK	MCS0
802.11ax (HE20)	1 to 13	1, 6, 11, 12, 13	OFDMA	BPSK	MCS0
802.11ax (HE40)	3 to 11	3, 6, 9, 10, 11	OFDMA	BPSK	MCS0

1TX

MODE	AVAILABLE CHANNEL	TESTED CHANNEL	MODULATION TECHNOLOGY	MODULATION TYPE	Data Rate Parameter	RU Configuration
802.11b	1 to 13	1, 6, 11, 12, 13	DSSS	DBPSK	1Mb/s	-
802.11g	1 to 13	1, 6, 11, 12, 13	OFDM	BPSK	6Mb/s	-
VHT20 (Output power only)	1 to 13	1, 6, 11, 12, 13	OFDM	BPSK	MCS0	-
VHT40 (Output power only)	3 to 11	3, 6, 9, 10, 11	OFDM	BPSK	MCS0	-
802.11ax (HE20)	1 to 13	1, 6, 11, 12, 13	OFDMA	BPSK	MCS0	-
802.11ax (HE40)	3 to 11	3, 6, 9, 10, 11	OFDMA	BPSK	MCS0	-
802.11ax (RU26)	1 to 13	1, 6, 11, 12, 13	OFDMA	BPSK	MCS0	26/0, 26/4, 26/8, 26/8, 26/8
802.11ax (RU52)	1 to 13	1, 6, 11, 12, 13	OFDMA	BPSK	MCS0	52/37, 52/39, 52/40, 52/40, 52/40
802.11ax (RU106)	1 to 13	1, 6, 11, 12, 13	OFDMA	BPSK	MCS0	106/53, 106/54, 106/54, 106/54, 106/54

Test Condition:

Applicable To	Environmental Conditions	Input Power (System)	Tested By
RE≥1G	25deg. C, 71%RH	120Vac, 60Hz	Sampson Chen
RE<1G	25deg. C, 71%RH	120Vac, 60Hz	Sampson Chen
PLC	25deg. C, 65%RH	120Vac, 60Hz	Sampson Chen
APCM	25deg. C, 60%RH	120Vac, 60Hz	Kevin Ko

3.3 Duty Cycle of Test Signal

For Mode 1:

Duty cycle of test signal is $\geq 98\%$, duty factor is not required.

802.11b: Duty cycle = $8.188 \text{ ms} / 8.203 \text{ ms} = 0.998$

802.11g: Duty cycle = $1.359 \text{ ms} / 1.375 \text{ ms} = 0.988$

802.11ax (HE20): Duty cycle = $0.985 \text{ ms} / 0.994 \text{ ms} = 0.991$

802.11ax (HE40): Duty cycle = $0.519 \text{ ms} / 0.528 \text{ ms} = 0.983$

802.11ax (RU26): Duty cycle = $4.881 / 4.893 = 0.998$

802.11ax (RU52): Duty cycle = $2.474 / 2.485 = 0.996$

802.11ax (RU106): Duty cycle = $1.2 / 1.208 = 0.993$

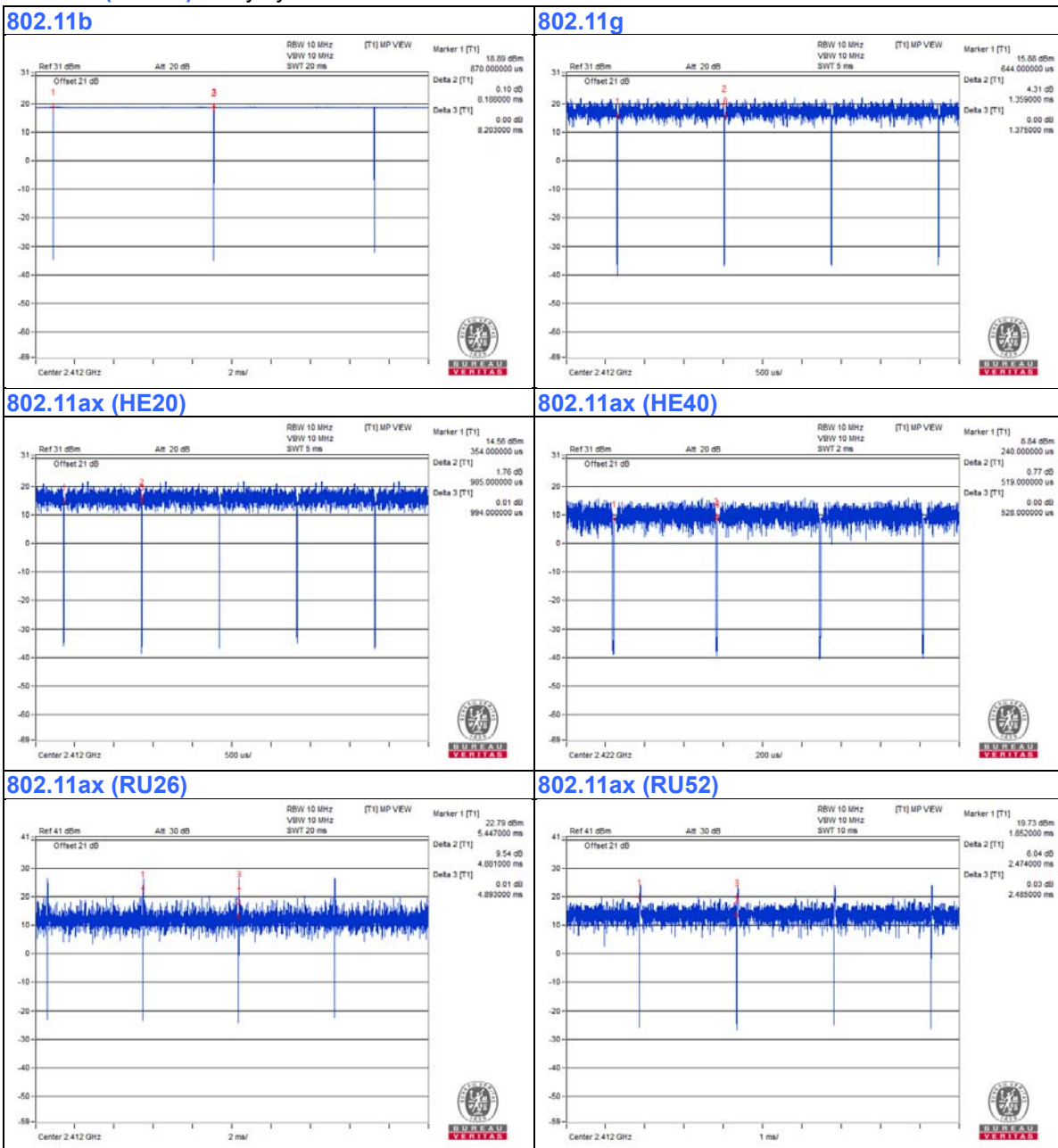

802.11ax (RU106)

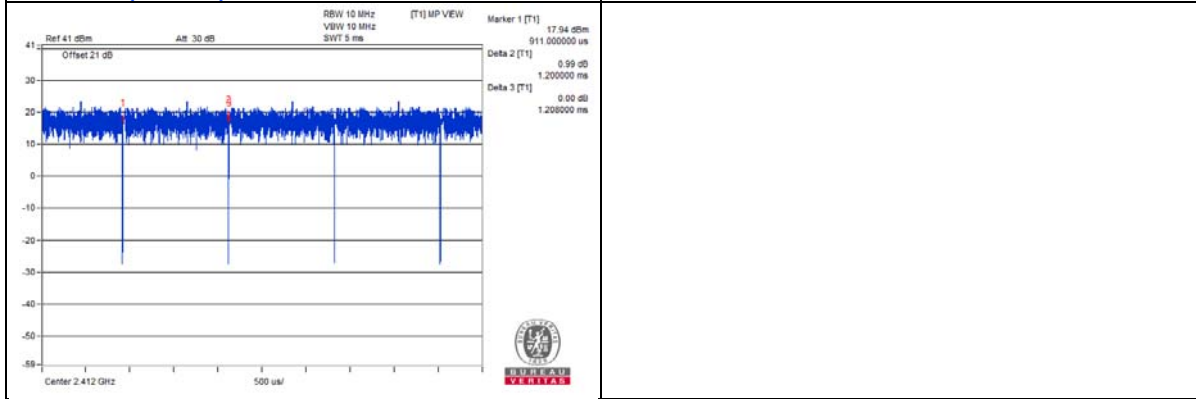

For Mode 2:

Duty cycle of test signal is $\geq 98\%$, duty factor is not required.

802.11b: Duty cycle = $8.188 \text{ ms} / 8.203 \text{ ms} = 0.998$

802.11g: Duty cycle = $1.359 \text{ ms} / 1.375 \text{ ms} = 0.988$

802.11ax (HE20): Duty cycle = $0.985 \text{ ms} / 0.994 \text{ ms} = 0.991$

802.11ax (HE40): Duty cycle = $0.519 \text{ ms} / 0.528 \text{ ms} = 0.983$

802.11ax (RU26): Duty cycle = $4.881 / 4.893 = 0.998$

802.11ax (RU52): Duty cycle = $2.474 / 2.485 = 0.996$

802.11ax (RU106): Duty cycle = $1.2 / 1.208 = 0.993$

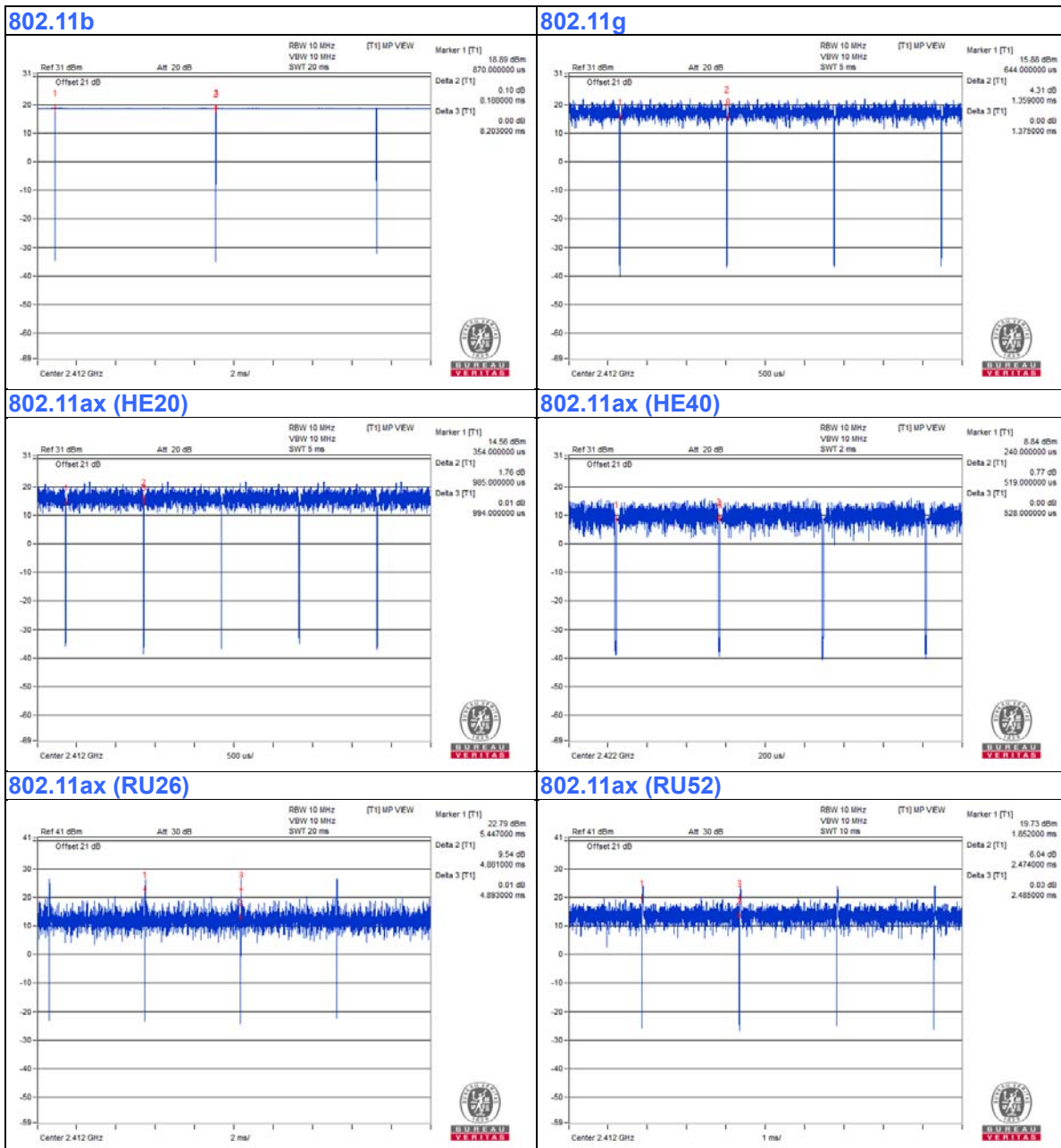

802.11ax (RU106)

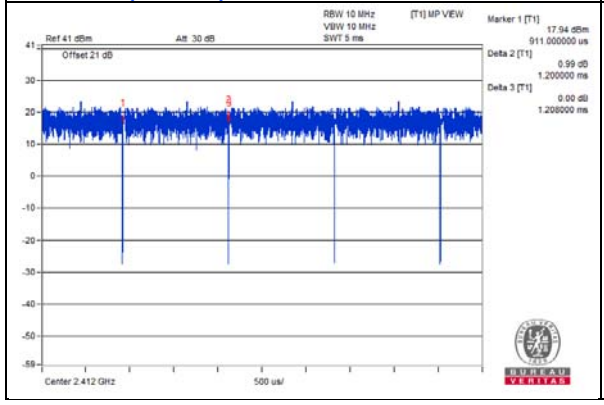

3.4 Description of Support Units

The EUT has been tested as an independent unit together with other necessary accessories or support units. The following support units or accessories were used to form a representative test configuration during the tests.

ID	Product	Brand	Model No.	Serial No.	FCC ID	Remarks
A.	Laptop	DELL	E6420	B92T3R1	FCC DoC	Provided by Lab
B.	Test Tool	Realtek	NA	NA	NA	Supplied by client
C.	Adapter	DELL	FA65NE0-00	NA	NA	Provided by Lab

Note:

1. All power cords of the above support units are non-shielded (1.8m).

ID	Descriptions	Qty.	Length (m)	Shielding (Yes/No)	Cores (Qty.)	Remarks
1.	DC Cable	1	1.8	No	1	Provided by Lab
2.	AC Cable	1	1	No	0	Provided by Lab

Note: The core(s) is(are) originally attached to the cable(s).

3.4.1 Configuration of System under Test
For AC Power Conducted Emissions test:

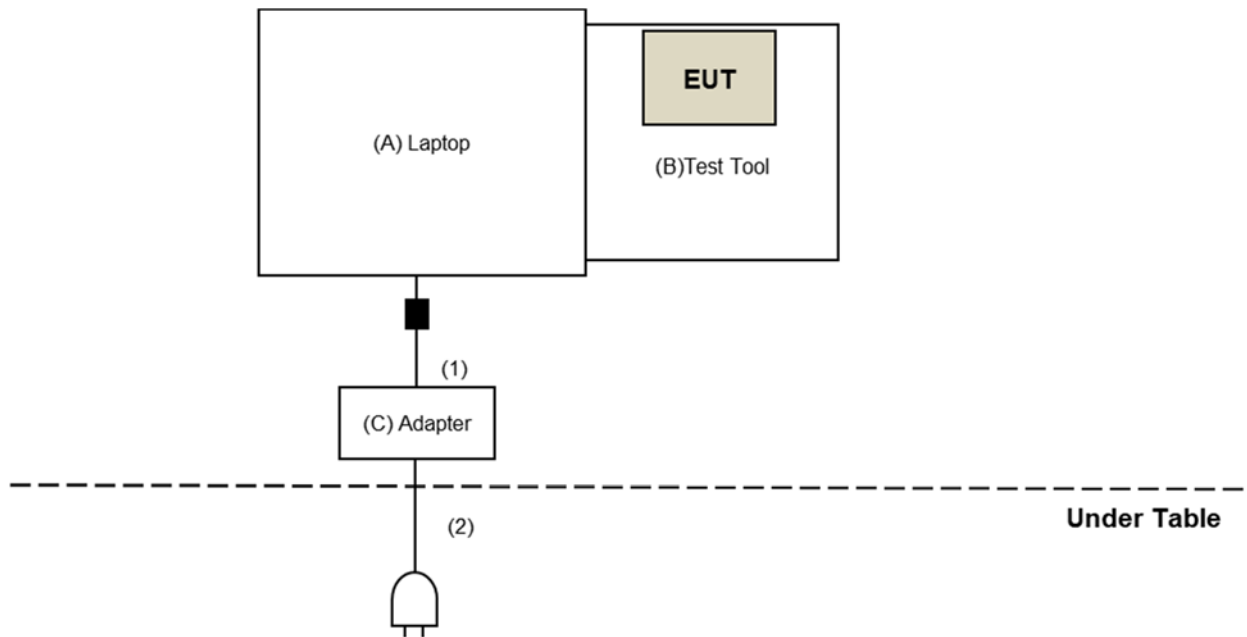

For Radiated Emissions test:

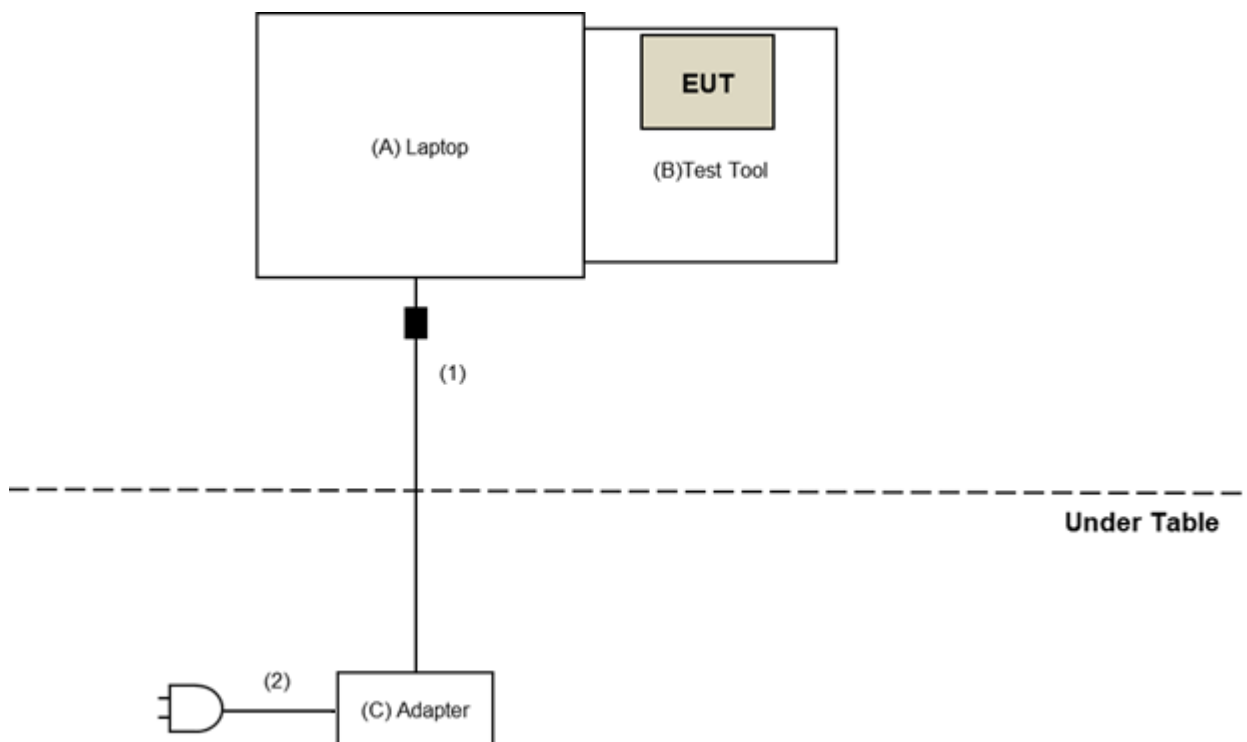

3.5 General Description of Applied Standards and references

The EUT is a RF Product. According to the specifications of the manufacturer, it must comply with the requirements of the following standards and references:

Test standard:

FCC Part 15, Subpart C (15.247)

ANSI C63.10-2013

All test items have been performed and recorded as per the above standards.

References Test Guidance:

KDB 558074 D01 15.247 Meas Guidance v05r02

KDB 662911 D01 Multiple Transmitter Output v02r01

All test items have been performed as a reference to the above KDB test guidance.

4 Test Types and Results

4.1 Radiated Emission and Bandedge Measurement

4.1.1 Limits of Radiated Emission and Bandedge Measurement

Radiated emissions which fall in the restricted bands must comply with the radiated emission limits specified as below table. Other emissions shall be at least 30dB below the highest level of the desired power:

Frequencies (MHz)	Field Strength (microvolts/meter)	Measurement Distance (meters)
0.009 ~ 0.490	2400/F(kHz)	300
0.490 ~ 1.705	24000/F(kHz)	30
1.705 ~ 30.0	30	30
30 ~ 88	100	3
88 ~ 216	150	3
216 ~ 960	200	3
Above 960	500	3

NOTE:

1. The lower limit shall apply at the transition frequencies.
2. Emission level (dBuV/m) = 20 log Emission level (uV/m).
3. For frequencies above 1000MHz, the field strength limits are based on average detector, however, the peak field strength of any emission shall not exceed the maximum permitted average limits, specified above by more than 20dB under any condition of modulation.

4.1.2 Test Instruments

For Radiated Emission (above 1GHz) and Bandedge test:

DESCRIPTION & MANUFACTURER	MODEL NO.	SERIAL NO.	CALIBRATED DATE	CALIBRATED UNTIL
Test Receiver R&S	ESR3	102528	Mar. 02, 2021	Mar. 01, 2022
Spectrum Analyzer Keysight	N9030B	MY57142938	Apr. 26, 2021	Apr. 25, 2022
Horn_Antenna SCHWARZBECK	BBHA 9120D	9120D-1819	Nov. 22, 2020	Nov. 21, 2021
Pre-Amplifier EMCI	EMC12630SE	980509	Apr. 26, 2021	Apr. 25, 2022
RF Cable EMCI	EMC104-SM-SM-1500	180503	Apr. 26, 2021	Apr. 25, 2022
RF Cable EMCI	EMC104-SM-SM-2000	180501	Apr. 26, 2021	Apr. 25, 2022
RF Cable EMCI	EMC104-SM-SM-6000	180506	Apr. 26, 2021	Apr. 25, 2022
Pre-Amplifier EMCI	EMC184045SE	980387	Jan. 11, 2021	Jan. 10, 2022
Horn_Antenna SCHWARZBECK	BBHA 9170	BBHA9170519	Nov. 22, 2020	Nov. 21, 2021
RF Cable	EMC102-KM-KM-1200	160924	Jan. 11, 2021	Jan. 10, 2022
RF Cable	EMC-KM-KM-4000	200214	Mar. 10, 2021	Mar. 09, 2022
Software	ADT_Radiated_V8.7.08	NA	NA	NA
Boresight Antenna Tower & Turn Table Max-Full	MF-7802BS	MF780208530	NA	NA

Note:

1. The calibration interval of the above test instruments is 12 months and the calibrations are traceable to NML/ROC and NIST/USA.
2. The test was performed in 966 Chamber No. 5.
3. Tested Date: May 05 to July 03, 2021

For Radiated Emission (below 1GHz) test:

DESCRIPTION & MANUFACTURER	MODEL NO.	SERIAL NO.	CALIBRATED DATE	CALIBRATED UNTIL
Test Receiver R&S	ESR3	102528	Mar. 02, 2021	Mar. 01, 2022
Spectrum Analyzer Keysight	N9030B	MY57142938	Apr. 26, 2021	Apr. 25, 2022
Pre-Amplifier EMCI	EMC001340	980142	May 24, 2021	May 23, 2022
Loop Antenna Electro-Metrics	EM-6879	264	Mar. 05, 2021	Mar. 04, 2022
RF Cable	5D-FB	LOOPCAB-001	Jan. 07, 2021	Jan. 06, 2022
RF Cable	5D-FB	LOOPCAB-002	Jan. 07, 2021	Jan. 06, 2022
Pre-Amplifier EMCI	EMC330N	980538	Apr. 26, 2021	Apr. 25, 2022
Trilog Broadband Antenna SCHWARZBECK	VULB9168	9168-0842	Nov. 03, 2020	Nov. 02, 2021
RF Cable	8D	966-5-1	Apr. 26, 2021	Apr. 25, 2022
RF Cable	8D	966-5-2	Apr. 26, 2021	Apr. 25, 2022
RF Cable	8D	966-5-3	Apr. 26, 2021	Apr. 25, 2022
Fixed attenuator Mini-Circuits	UNAT-5+	PAD-ATT5-02	Jan. 11, 2021	Jan. 10, 2022
Software	ADT_Radiated_V8.7.08	NA	NA	NA
Boresight Antenna Tower & Turn Table Max-Full	MF-7802BS	MF780208530	NA	NA

Note:

1. The calibration interval of the above test instruments is 12 months and the calibrations are traceable to NML/ROC and NIST/USA.
2. The test was performed in 966 Chamber No. 5.
3. Tested Date: June 19, 2021

For other test items:

DESCRIPTION & MANUFACTURER	MODEL NO.	SERIAL NO.	CALIBRATED DATE	CALIBRATED UNTIL
Spectrum Analyzer R&S	FSV40	101516	Mar. 08, 2021	Mar. 07, 2022
Power meter Anritsu	ML2495A	1529002	July 22, 2020	July 21, 2021
Power sensor Anritsu	MA2411B	1339443	May 31, 2021	May 30, 2022
10dB Attenuator Woken	MDCS18N-10	MDCS18N-10-01	Apr. 13, 2021	Apr. 12, 2022
Software	ADT_RF Test Software V6.6.5.4	NA	NA	NA

- NOTE:**
1. The test was performed in Oven room 2.
 2. The calibration interval of the above test instruments is 12 months and the calibrations are traceable to NML/ROC and NIST/USA.
 3. Tested Date: June 01 to July 08, 2021

4.1.3 Test Procedures

For Radiated emission below 30MHz

- a. The EUT was placed on the top of a rotating table 0.8 meters above the ground at a 3 meter chamber room. The table was rotated 360 degrees to determine the position of the highest radiation.
- b. The EUT was set 3 meters away from the interference-receiving antenna, which was mounted on the top of a variable-height antenna tower.
- c. Parallel, perpendicular, and ground-parallel orientations of the antenna are set to make the measurement.
- d. For each suspected emission, the EUT was arranged to its worst case and the rotatable table was turned from 0 degrees to 360 degrees to find the maximum reading.
- e. The test-receiver system was set to Quasi-Peak Detect Function and Specified Bandwidth with Maximum Hold Mode.

NOTE:

1. The resolution bandwidth and video bandwidth of test receiver/spectrum analyzer is 9kHz at frequency below 30MHz.

For Radiated emission above 30MHz

- a. The EUT was placed on the top of a rotating table 0.8 meters (for 30MHz ~ 1GHz) / 1.5 meters (for above 1GHz) above the ground at 3 meter chamber room for test. The table was rotated 360 degrees to determine the position of the highest radiation.
- b. The EUT was set 3 meters away from the interference-receiving antenna, which was mounted on the top of a variable-height antenna tower.
- c. The height of antenna is varied from one meter to four meters above the ground to determine the maximum value of the field strength. Both horizontal and vertical polarizations of the antenna are set to make the measurement.
- d. For each suspected emission, the EUT was arranged to its worst case and then the antenna was tuned to heights from 1 meter to 4 meters and the rotatable table was turned from 0 degrees to 360 degrees to find the maximum reading.
- e. The test-receiver system was set to quasi-peak detect function and specified bandwidth with maximum hold mode when the test frequency is below 1 GHz.
- f. The test-receiver system was set to peak and average detects function and specified bandwidth with maximum hold mode when the test frequency is above 1 GHz. If the peak reading value also meets average limit, measurement with the average detector is unnecessary.

Note:

1. The resolution bandwidth and video bandwidth of test receiver/spectrum analyzer is 120kHz for Quasi-peak detection (QP) at frequency below 1GHz.
2. The resolution bandwidth of test receiver/spectrum analyzer is 1 MHz and the video bandwidth is 3 MHz for Peak detection (PK) at frequency above 1GHz.
3. The resolution bandwidth of test receiver/spectrum analyzer is 1MHz and the video bandwidth is $\geq 1/T$ (Duty cycle < 98%) or 10Hz (Duty cycle $\geq 98\%$) for Average detection (AV) at frequency above 1GHz.
4. All modes of operation were investigated and the worst-case emissions are reported.

4.1.4 Deviation from Test Standard

No deviation.

4.1.5 Test Setup

For Radiated emission below 30MHz

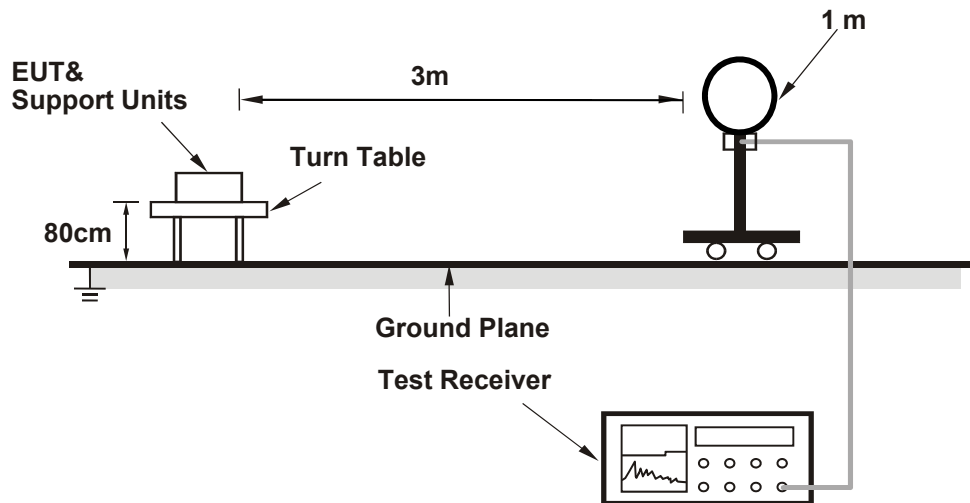

For Radiated emission 30MHz to 1GHz

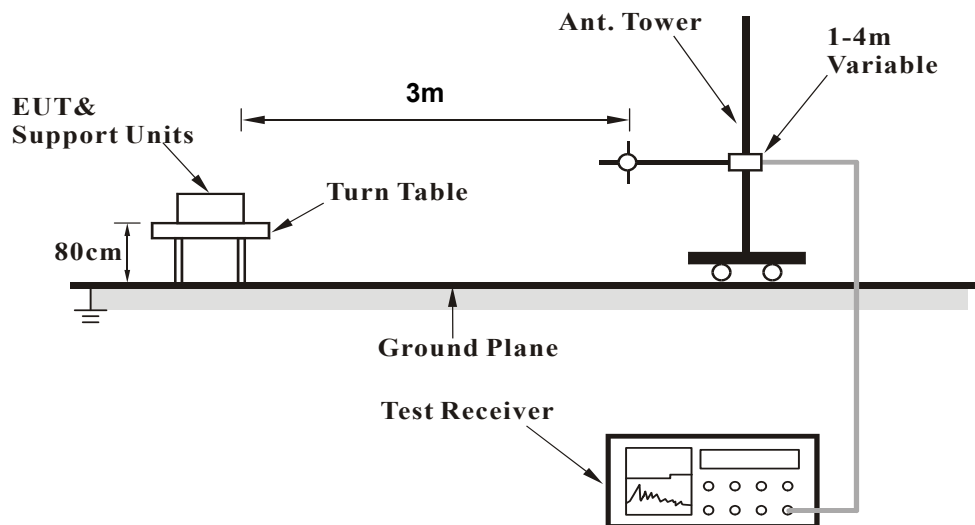

For Radiated emission above 1GHz

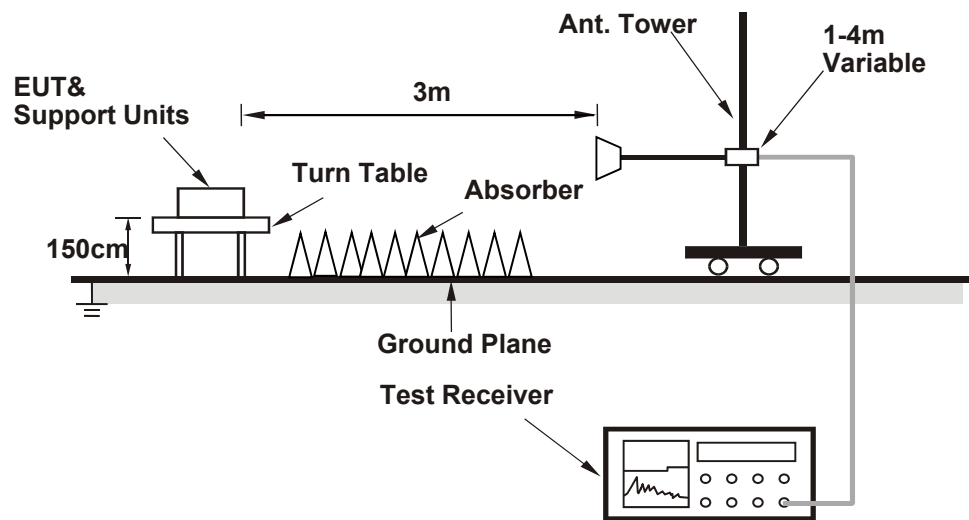

For the actual test configuration, please refer to the attached file (Test Setup Photo).

4.1.6 EUT Operating Conditions

- Connected the EUT with the Laptop which is placed on testing table.
- Controlling software (RTL8852B MP Toolkit V1.0.16) has been activated to set the EUT under transmission condition continuously at specific channel frequency.

4.1.7 Test Results (Mode 1)

Dipole Antenna

RF Mode	TX 802.11b	Channel	CH 1 : 2412 MHz
Frequency Range	1GHz ~ 25GHz	Detector Function	Peak (PK) Average (AV)

Antenna Polarity & Test Distance : Horizontal at 3 m

No	Frequency (MHz)	Emission Level (dBuV/m)	Limit (dBuV/m)	Margin (dB)	Antenna Height (m)	Table Angle (Degree)	Raw Value (dBuV)	Correction Factor (dB/m)
1	2373.90	55.7 PK	74.0	-18.3	1.50 H	118	58.3	-2.6
2	2373.90	44.0 AV	54.0	-10.0	1.50 H	118	46.6	-2.6
3	2389.00	52.5 PK	74.0	-21.5	1.50 H	118	55.2	-2.7
4	2389.00	44.3 AV	54.0	-9.7	1.50 H	118	47.0	-2.7
5	*2412.00	103.6 PK			1.50 H	118	106.3	-2.7
6	*2412.00	101.3 AV			1.50 H	118	104.0	-2.7
7	4824.00	45.5 PK	74.0	-28.5	1.04 H	269	43.7	1.8
8	4824.00	42.7 AV	54.0	-11.3	1.04 H	269	40.9	1.8

Antenna Polarity & Test Distance : Vertical at 3 m

No	Frequency (MHz)	Emission Level (dBuV/m)	Limit (dBuV/m)	Margin (dB)	Antenna Height (m)	Table Angle (Degree)	Raw Value (dBuV)	Correction Factor (dB/m)
1	2385.30	59.1 PK	74.0	-14.9	1.67 V	123	61.8	-2.7
2	2385.30	49.5 AV	54.0	-4.5	1.67 V	123	52.2	-2.7
3	*2412.00	113.7 PK			1.67 V	123	116.4	-2.7
4	*2412.00	111.3 AV			1.67 V	123	114.0	-2.7
5	4824.00	44.3 PK	74.0	-29.7	1.28 V	78	42.5	1.8
6	4824.00	41.3 AV	54.0	-12.7	1.28 V	78	39.5	1.8

Remarks:

1. Emission Level(dBuV/m) = Raw Value(dBuV) + Correction Factor(dB/m)
2. Correction Factor(dB/m) = Antenna Factor(dB/m) + Cable Factor(dB) – Pre-Amplifier Factor(dB)
3. Margin value = Emission Level – Limit value
4. The other emission levels were very low against the limit.
5. " * ": Fundamental frequency.

RF Mode	TX 802.11b	Channel	CH 6 : 2437 MHz
Frequency Range	1GHz ~ 25GHz	Detector Function	Peak (PK) Average (AV)

Antenna Polarity & Test Distance : Horizontal at 3 m

No	Frequency (MHz)	Emission Level (dBuV/m)	Limit (dBuV/m)	Margin (dB)	Antenna Height (m)	Table Angle (Degree)	Raw Value (dBuV)	Correction Factor (dB/m)
1	2390.00	54.3 PK	74.0	-19.7	1.46 H	132	57.0	-2.7
2	2390.00	41.3 AV	54.0	-12.7	1.46 H	132	44.0	-2.7
3	*2437.00	104.8 PK			1.46 H	132	107.5	-2.7
4	*2437.00	102.5 AV			1.46 H	132	105.2	-2.7
5	2483.50	57.3 PK	74.0	-16.7	1.46 H	132	60.1	-2.8
6	2483.50	41.9 AV	54.0	-12.1	1.46 H	132	44.7	-2.8
7	4874.00	45.9 PK	74.0	-28.1	1.01 H	267	44.2	1.7
8	4874.00	42.9 AV	54.0	-11.1	1.01 H	267	41.2	1.7
9	7311.00	49.3 PK	74.0	-24.7	1.48 H	288	42.1	7.2
10	7311.00	44.1 AV	54.0	-9.9	1.48 H	288	36.9	7.2

Antenna Polarity & Test Distance : Vertical at 3 m

No	Frequency (MHz)	Emission Level (dBuV/m)	Limit (dBuV/m)	Margin (dB)	Antenna Height (m)	Table Angle (Degree)	Raw Value (dBuV)	Correction Factor (dB/m)
1	2390.00	58.8 PK	74.0	-15.2	1.63 V	128	61.5	-2.7
2	2390.00	46.6 AV	54.0	-7.4	1.63 V	128	49.3	-2.7
3	*2437.00	114.3 PK			1.63 V	128	117.0	-2.7
4	*2437.00	112.6 AV			1.63 V	128	115.3	-2.7
5	2483.50	61.2 PK	74.0	-12.8	1.63 V	128	64.0	-2.8
6	2483.50	46.1 AV	54.0	-7.9	1.63 V	128	48.9	-2.8
7	4874.00	44.8 PK	74.0	-29.2	1.23 V	87	43.1	1.7
8	4874.00	41.8 AV	54.0	-12.2	1.23 V	87	40.1	1.7
9	7311.00	54.2 PK	74.0	-19.8	2.93 V	50	47.0	7.2
10	7311.00	50.8 AV	54.0	-3.2	2.93 V	50	43.6	7.2

Remarks:

1. Emission Level(dBuV/m) = Raw Value(dBuV) + Correction Factor(dB/m)
2. Correction Factor(dB/m) = Antenna Factor(dB/m) + Cable Factor(dB) – Pre-Amplifier Factor(dB)
3. Margin value = Emission Level – Limit value
4. The other emission levels were very low against the limit.
5. " * " : Fundamental frequency.

RF Mode	TX 802.11b	Channel	CH 11 : 2462 MHz
Frequency Range	1GHz ~ 25GHz	Detector Function	Peak (PK) Average (AV)

Antenna Polarity & Test Distance : Horizontal at 3 m

No	Frequency (MHz)	Emission Level (dBuV/m)	Limit (dBuV/m)	Margin (dB)	Antenna Height (m)	Table Angle (Degree)	Raw Value (dBuV)	Correction Factor (dB/m)
1	*2462.00	106.2 PK			1.48 H	112	109.0	-2.8
2	*2462.00	102.3 AV			1.48 H	112	105.1	-2.8
3	2483.50	55.8 PK	74.0	-18.2	1.48 H	112	58.6	-2.8
4	2483.50	45.4 AV	54.0	-8.6	1.48 H	112	48.2	-2.8
5	2491.70	57.1 PK	74.0	-16.9	1.48 H	112	59.9	-2.8
6	2491.70	44.8 AV	54.0	-9.2	1.48 H	112	47.6	-2.8
7	4924.00	44.9 PK	74.0	-29.1	1.00 H	258	43.1	1.8
8	4924.00	42.1 AV	54.0	-11.9	1.00 H	258	40.3	1.8
9	7386.00	46.7 PK	74.0	-27.3	1.45 H	302	39.3	7.4
10	7386.00	41.8 AV	54.0	-12.2	1.45 H	302	34.4	7.4

Antenna Polarity & Test Distance : Vertical at 3 m

No	Frequency (MHz)	Emission Level (dBuV/m)	Limit (dBuV/m)	Margin (dB)	Antenna Height (m)	Table Angle (Degree)	Raw Value (dBuV)	Correction Factor (dB/m)
1	*2462.00	113.5 PK			1.63 V	154	116.3	-2.8
2	*2462.00	111.0 AV			1.63 V	154	113.8	-2.8
3	2484.40	58.6 PK	74.0	-15.4	1.63 V	154	61.4	-2.8
4	2484.40	48.6 AV	54.0	-5.4	1.63 V	154	51.4	-2.8
5	2484.80	58.1 PK	74.0	-15.9	1.63 V	154	60.9	-2.8
6	2484.80	50.3 AV	54.0	-3.7	1.63 V	154	53.1	-2.8
7	4924.00	43.6 PK	74.0	-30.4	1.29 V	87	41.8	1.8
8	4924.00	40.9 AV	54.0	-13.1	1.29 V	87	39.1	1.8
9	7386.00	51.0 PK	74.0	-23.0	2.67 V	87	43.6	7.4
10	7386.00	47.3 AV	54.0	-6.7	2.67 V	87	39.9	7.4

Remarks:

1. Emission Level(dBuV/m) = Raw Value(dBuV) + Correction Factor(dB/m)
2. Correction Factor(dB/m) = Antenna Factor(dB/m) + Cable Factor(dB) – Pre-Amplifier Factor(dB)
3. Margin value = Emission Level – Limit value
4. The other emission levels were very low against the limit.
5. " * " : Fundamental frequency.

RF Mode	TX 802.11b	Channel	CH 12 : 2467 MHz
Frequency Range	1GHz ~ 25GHz	Detector Function	Peak (PK) Average (AV)

Antenna Polarity & Test Distance : Horizontal at 3 m

No	Frequency (MHz)	Emission Level (dBuV/m)	Limit (dBuV/m)	Margin (dB)	Antenna Height (m)	Table Angle (Degree)	Raw Value (dBuV)	Correction Factor (dB/m)
1	*2467.00	97.1 PK			1.49 H	113	99.9	-2.8
2	*2467.00	94.6 AV			1.49 H	113	97.4	-2.8
3	2484.70	55.3 PK	74.0	-18.7	1.49 H	113	58.1	-2.8
4	2484.70	44.4 AV	54.0	-9.6	1.49 H	113	47.2	-2.8
5	4934.00	45.0 PK	74.0	-29.0	1.05 H	269	43.2	1.8
6	4934.00	42.3 AV	54.0	-11.7	1.05 H	269	40.5	1.8
7	7401.00	46.9 PK	74.0	-27.1	1.43 H	292	39.4	7.5
8	7401.00	42.0 AV	54.0	-12.0	1.43 H	292	34.5	7.5

Antenna Polarity & Test Distance : Vertical at 3 m

No	Frequency (MHz)	Emission Level (dBuV/m)	Limit (dBuV/m)	Margin (dB)	Antenna Height (m)	Table Angle (Degree)	Raw Value (dBuV)	Correction Factor (dB/m)
1	*2467.00	107.6 PK			1.67 V	297	110.4	-2.8
2	*2467.00	105.2 AV			1.67 V	297	108.0	-2.8
3	2484.22	59.8 PK	74.0	-14.2	1.67 V	297	62.6	-2.8
4	2484.22	52.3 AV	54.0	-1.7	1.67 V	297	55.1	-2.8
5	4934.00	43.6 PK	74.0	-30.4	1.24 V	83	41.8	1.8
6	4934.00	40.9 AV	54.0	-13.1	1.24 V	83	39.1	1.8
7	7401.00	50.6 PK	74.0	-23.4	2.63 V	80	43.1	7.5
8	7401.00	47.1 AV	54.0	-6.9	2.63 V	80	39.6	7.5

Remarks:

1. Emission Level(dBuV/m) = Raw Value(dBuV) + Correction Factor(dB/m)
2. Correction Factor(dB/m) = Antenna Factor(dB/m) + Cable Factor(dB) – Pre-Amplifier Factor(dB)
3. Margin value = Emission Level – Limit value
4. The other emission levels were very low against the limit.
5. " * ": Fundamental frequency.

RF Mode	TX 802.11b	Channel	CH 13 : 2472 MHz
Frequency Range	1GHz ~ 25GHz	Detector Function	Peak (PK) Average (AV)

Antenna Polarity & Test Distance : Horizontal at 3 m

No	Frequency (MHz)	Emission Level (dBuV/m)	Limit (dBuV/m)	Margin (dB)	Antenna Height (m)	Table Angle (Degree)	Raw Value (dBuV)	Correction Factor (dB/m)
1	*2472.00	96.6 PK			1.46 H	116	99.4	-2.8
2	*2472.00	93.6 AV			1.46 H	116	96.4	-2.8
3	2483.50	57.0 PK	74.0	-17.0	1.46 H	116	59.8	-2.8
4	2483.50	46.5 AV	54.0	-7.5	1.46 H	116	49.3	-2.8
5	4944.00	44.6 PK	74.0	-29.4	1.05 H	249	42.8	1.8
6	4944.00	42.0 AV	54.0	-12.0	1.05 H	249	40.2	1.8
7	7416.00	46.9 PK	74.0	-27.1	1.41 H	302	39.4	7.5
8	7416.00	41.9 AV	54.0	-12.1	1.41 H	302	34.4	7.5

Antenna Polarity & Test Distance : Vertical at 3 m

No	Frequency (MHz)	Emission Level (dBuV/m)	Limit (dBuV/m)	Margin (dB)	Antenna Height (m)	Table Angle (Degree)	Raw Value (dBuV)	Correction Factor (dB/m)
1	*2472.00	104.7 PK			1.59 V	126	107.5	-2.8
2	*2472.00	102.2 AV			1.59 V	126	105.0	-2.8
3	2484.60	59.8 PK	74.0	-14.2	1.59 V	126	62.6	-2.8
4	2484.60	52.5 AV	54.0	-1.5	1.59 V	126	55.3	-2.8
5	4944.00	43.9 PK	74.0	-30.1	1.24 V	101	42.1	1.8
6	4944.00	41.4 AV	54.0	-12.6	1.24 V	101	39.6	1.8
7	7416.00	50.8 PK	74.0	-23.2	2.73 V	74	43.3	7.5
8	7416.00	47.3 AV	54.0	-6.7	2.73 V	74	39.8	7.5

Remarks:

1. Emission Level(dBuV/m) = Raw Value(dBuV) + Correction Factor(dB/m)
2. Correction Factor(dB/m) = Antenna Factor(dB/m) + Cable Factor(dB) – Pre-Amplifier Factor(dB)
3. Margin value = Emission Level – Limit value
4. The other emission levels were very low against the limit.
5. " * ": Fundamental frequency.

RF Mode	TX 802.11g	Channel	CH 1 : 2412 MHz
Frequency Range	1GHz ~ 25GHz	Detector Function	Peak (PK) Average (AV)

Antenna Polarity & Test Distance : Horizontal at 3 m

No	Frequency (MHz)	Emission Level (dBuV/m)	Limit (dBuV/m)	Margin (dB)	Antenna Height (m)	Table Angle (Degree)	Raw Value (dBuV)	Correction Factor (dB/m)
1	2390.00	58.2 PK	74.0	-15.8	1.24 H	109	60.9	-2.7
2	2390.00	45.1 AV	54.0	-8.9	1.24 H	109	47.8	-2.7
3	*2412.00	107.1 PK			1.24 H	109	109.8	-2.7
4	*2412.00	96.2 AV			1.24 H	109	98.9	-2.7
5	4824.00	44.6 PK	74.0	-29.4	1.00 H	268	42.8	1.8
6	4824.00	41.7 AV	54.0	-12.3	1.00 H	268	39.9	1.8

Antenna Polarity & Test Distance : Vertical at 3 m

No	Frequency (MHz)	Emission Level (dBuV/m)	Limit (dBuV/m)	Margin (dB)	Antenna Height (m)	Table Angle (Degree)	Raw Value (dBuV)	Correction Factor (dB/m)
1	2390.00	61.2 PK	74.0	-12.8	1.65 V	131	63.9	-2.7
2	2390.00	47.7 AV	54.0	-6.3	1.65 V	131	50.4	-2.7
3	*2412.00	114.1 PK			1.65 V	131	116.8	-2.7
4	*2412.00	105.0 AV			1.65 V	131	107.7	-2.7
5	4824.00	43.4 PK	74.0	-30.6	1.25 V	81	41.6	1.8
6	4824.00	40.6 AV	54.0	-13.4	1.25 V	81	38.8	1.8

Remarks:

1. Emission Level(dBuV/m) = Raw Value(dBuV) + Correction Factor(dB/m)
2. Correction Factor(dB/m) = Antenna Factor(dB/m) + Cable Factor(dB) – Pre-Amplifier Factor(dB)
3. Margin value = Emission Level – Limit value
4. The other emission levels were very low against the limit.
5. " * " : Fundamental frequency.

RF Mode	TX 802.11g	Channel	CH 6 : 2437 MHz
Frequency Range	1GHz ~ 25GHz	Detector Function	Peak (PK) Average (AV)

Antenna Polarity & Test Distance : Horizontal at 3 m

No	Frequency (MHz)	Emission Level (dBuV/m)	Limit (dBuV/m)	Margin (dB)	Antenna Height (m)	Table Angle (Degree)	Raw Value (dBuV)	Correction Factor (dB/m)
1	2390.00	54.9 PK	74.0	-19.1	1.28 H	96	57.6	-2.7
2	2390.00	41.6 AV	54.0	-12.4	1.28 H	96	44.3	-2.7
3	*2437.00	111.4 PK			1.28 H	96	114.1	-2.7
4	*2437.00	100.7 AV			1.28 H	96	103.4	-2.7
5	2483.50	57.8 PK	74.0	-16.2	1.28 H	96	60.6	-2.8
6	2483.50	42.1 AV	54.0	-11.9	1.28 H	96	44.9	-2.8
7	4874.00	45.2 PK	74.0	-28.8	1.05 H	257	43.5	1.7
8	4874.00	42.2 AV	54.0	-11.8	1.05 H	257	40.5	1.7
9	7311.00	46.7 PK	74.0	-27.3	1.46 H	288	39.5	7.2
10	7311.00	42.1 AV	54.0	-11.9	1.46 H	288	34.9	7.2

Antenna Polarity & Test Distance : Vertical at 3 m

No	Frequency (MHz)	Emission Level (dBuV/m)	Limit (dBuV/m)	Margin (dB)	Antenna Height (m)	Table Angle (Degree)	Raw Value (dBuV)	Correction Factor (dB/m)
1	2390.00	58.6 PK	74.0	-15.4	1.54 V	122	61.3	-2.7
2	2390.00	46.6 AV	54.0	-7.4	1.54 V	122	49.3	-2.7
3	*2437.00	119.6 PK			1.54 V	122	122.3	-2.7
4	*2437.00	110.6 AV			1.54 V	122	113.3	-2.7
5	2483.50	61.4 PK	74.0	-12.6	1.54 V	122	64.2	-2.8
6	2483.50	46.5 AV	54.0	-7.5	1.54 V	122	49.3	-2.8
7	4874.00	43.7 PK	74.0	-30.3	1.32 V	81	42.0	1.7
8	4874.00	41.2 AV	54.0	-12.8	1.32 V	81	39.5	1.7
9	7311.00	51.1 PK	74.0	-22.9	2.64 V	93	43.9	7.2
10	7311.00	47.5 AV	54.0	-6.5	2.64 V	93	40.3	7.2

Remarks:

1. Emission Level(dBuV/m) = Raw Value(dBuV) + Correction Factor(dB/m)
2. Correction Factor(dB/m) = Antenna Factor(dB/m) + Cable Factor(dB) – Pre-Amplifier Factor(dB)
3. Margin value = Emission Level – Limit value
4. The other emission levels were very low against the limit.
5. " * ": Fundamental frequency.

RF Mode	TX 802.11g	Channel	CH 11 : 2462 MHz
Frequency Range	1GHz ~ 25GHz	Detector Function	Peak (PK) Average (AV)

Antenna Polarity & Test Distance : Horizontal at 3 m

No	Frequency (MHz)	Emission Level (dBuV/m)	Limit (dBuV/m)	Margin (dB)	Antenna Height (m)	Table Angle (Degree)	Raw Value (dBuV)	Correction Factor (dB/m)
1	*2462.00	108.3 PK			1.50 H	115	111.1	-2.8
2	*2462.00	97.3 AV			1.50 H	115	100.1	-2.8
3	2483.50	57.6 PK	74.0	-16.4	1.50 H	115	60.4	-2.8
4	2483.50	46.0 AV	54.0	-8.0	1.50 H	115	48.8	-2.8
5	2484.30	60.4 PK	74.0	-13.6	1.50 H	115	63.2	-2.8
6	2484.30	45.8 AV	54.0	-8.2	1.50 H	115	48.6	-2.8
7	4924.00	45.3 PK	74.0	-28.7	1.05 H	269	43.5	1.8
8	4924.00	42.4 AV	54.0	-11.6	1.05 H	269	40.6	1.8
9	7386.00	47.2 PK	74.0	-26.8	1.47 H	303	39.8	7.4
10	7386.00	42.0 AV	54.0	-12.0	1.47 H	303	34.6	7.4

Antenna Polarity & Test Distance : Vertical at 3 m

No	Frequency (MHz)	Emission Level (dBuV/m)	Limit (dBuV/m)	Margin (dB)	Antenna Height (m)	Table Angle (Degree)	Raw Value (dBuV)	Correction Factor (dB/m)
1	*2462.00	113.9 PK			1.69 V	128	116.7	-2.8
2	*2462.00	105.3 AV			1.69 V	128	108.1	-2.8
3	2483.50	58.2 PK	74.0	-15.8	1.69 V	128	61.0	-2.8
4	2483.50	48.3 AV	54.0	-5.7	1.69 V	128	51.1	-2.8
5	2485.30	63.1 PK	74.0	-10.9	1.69 V	128	65.9	-2.8
6	2485.30	47.5 AV	54.0	-6.5	1.69 V	128	50.3	-2.8
7	4924.00	43.8 PK	74.0	-30.2	1.24 V	80	42.0	1.8
8	4924.00	41.0 AV	54.0	-13.0	1.24 V	80	39.2	1.8
9	7386.00	50.6 PK	74.0	-23.4	2.67 V	77	43.2	7.4
10	7386.00	47.1 AV	54.0	-6.9	2.67 V	77	39.7	7.4

Remarks:

1. Emission Level(dBuV/m) = Raw Value(dBuV) + Correction Factor(dB/m)
2. Correction Factor(dB/m) = Antenna Factor(dB/m) + Cable Factor(dB) – Pre-Amplifier Factor(dB)
3. Margin value = Emission Level – Limit value
4. The other emission levels were very low against the limit.
5. " * ": Fundamental frequency.

RF Mode	TX 802.11g	Channel	CH 12 : 2467 MHz
Frequency Range	1GHz ~ 25GHz	Detector Function	Peak (PK) Average (AV)

Antenna Polarity & Test Distance : Horizontal at 3 m

No	Frequency (MHz)	Emission Level (dBuV/m)	Limit (dBuV/m)	Margin (dB)	Antenna Height (m)	Table Angle (Degree)	Raw Value (dBuV)	Correction Factor (dB/m)
1	*2467.00	104.0 PK			1.54 H	113	106.8	-2.8
2	*2467.00	93.3 AV			1.54 H	113	96.1	-2.8
3	2483.50	58.3 PK	74.0	-15.7	1.54 H	113	61.1	-2.8
4	2483.50	45.6 AV	54.0	-8.4	1.54 H	113	48.4	-2.8
5	4934.00	45.9 PK	74.0	-28.1	1.04 H	264	44.1	1.8
6	4934.00	42.8 AV	54.0	-11.2	1.04 H	264	41.0	1.8
7	7401.00	47.2 PK	74.0	-26.8	1.50 H	306	39.7	7.5
8	7401.00	42.1 AV	54.0	-11.9	1.50 H	306	34.6	7.5

Antenna Polarity & Test Distance : Vertical at 3 m

No	Frequency (MHz)	Emission Level (dBuV/m)	Limit (dBuV/m)	Margin (dB)	Antenna Height (m)	Table Angle (Degree)	Raw Value (dBuV)	Correction Factor (dB/m)
1	*2467.00	110.0 PK			1.67 V	125	112.8	-2.8
2	*2467.00	101.0 AV			1.67 V	125	103.8	-2.8
3	2483.50	58.2 PK	74.0	-15.8	1.67 V	125	61.0	-2.8
4	2483.50	47.5 AV	54.0	-6.5	1.67 V	125	50.3	-2.8
5	2484.40	59.8 PK	74.0	-14.2	1.67 V	125	62.6	-2.8
6	2484.40	46.1 AV	54.0	-7.9	1.67 V	125	48.9	-2.8
7	4934.00	44.1 PK	74.0	-29.9	1.30 V	64	42.3	1.8
8	4934.00	41.1 AV	54.0	-12.9	1.30 V	64	39.3	1.8
9	7401.00	49.9 PK	74.0	-24.1	2.70 V	84	42.4	7.5
10	7401.00	46.6 AV	54.0	-7.4	2.70 V	84	39.1	7.5

Remarks:

1. Emission Level(dBuV/m) = Raw Value(dBuV) + Correction Factor(dB/m)
2. Correction Factor(dB/m) = Antenna Factor(dB/m) + Cable Factor(dB) – Pre-Amplifier Factor(dB)
3. Margin value = Emission Level – Limit value
4. The other emission levels were very low against the limit.
5. " * ": Fundamental frequency.

RF Mode	TX 802.11g	Channel	CH 13 : 2472 MHz
Frequency Range	1GHz ~ 25GHz	Detector Function	Peak (PK) Average (AV)

Antenna Polarity & Test Distance : Horizontal at 3 m

No	Frequency (MHz)	Emission Level (dBuV/m)	Limit (dBuV/m)	Margin (dB)	Antenna Height (m)	Table Angle (Degree)	Raw Value (dBuV)	Correction Factor (dB/m)
1	*2472.00	102.6 PK			1.44 H	112	105.4	-2.8
2	*2472.00	92.2 AV			1.44 H	112	95.0	-2.8
3	2483.50	59.7 PK	74.0	-14.3	1.44 H	112	62.5	-2.8
4	2483.50	45.6 AV	54.0	-8.4	1.44 H	112	48.4	-2.8
5	4944.00	45.2 PK	74.0	-28.8	1.08 H	268	43.4	1.8
6	4944.00	42.1 AV	54.0	-11.9	1.08 H	268	40.3	1.8
7	7416.00	47.1 PK	74.0	-26.9	1.50 H	288	39.6	7.5
8	7416.00	42.0 AV	54.0	-12.0	1.50 H	288	34.5	7.5

Antenna Polarity & Test Distance : Vertical at 3 m

No	Frequency (MHz)	Emission Level (dBuV/m)	Limit (dBuV/m)	Margin (dB)	Antenna Height (m)	Table Angle (Degree)	Raw Value (dBuV)	Correction Factor (dB/m)
1	*2472.00	109.2 PK			1.54 V	129	112.0	-2.8
2	*2472.00	100.0 AV			1.54 V	129	102.8	-2.8
3	2483.80	64.9 PK	74.0	-9.1	1.54 V	129	67.7	-2.8
4	2483.80	48.4 AV	54.0	-5.6	1.54 V	129	51.2	-2.8
5	4944.00	43.5 PK	74.0	-30.5	1.28 V	91	41.7	1.8
6	4944.00	40.9 AV	54.0	-13.1	1.28 V	91	39.1	1.8
7	7416.00	50.4 PK	74.0	-23.6	2.62 V	71	42.9	7.5
8	7416.00	47.0 AV	54.0	-7.0	2.62 V	71	39.5	7.5

Remarks:

1. Emission Level(dBuV/m) = Raw Value(dBuV) + Correction Factor(dB/m)
2. Correction Factor(dB/m) = Antenna Factor(dB/m) + Cable Factor(dB) – Pre-Amplifier Factor(dB)
3. Margin value = Emission Level – Limit value
4. The other emission levels were very low against the limit.
5. " * ": Fundamental frequency.

RF Mode	TX 802.11ax (HE20)	Channel	CH 1 : 2412 MHz
Frequency Range	1GHz ~ 25GHz	Detector Function	Peak (PK) Average (AV)

Antenna Polarity & Test Distance : Horizontal at 3 m

No	Frequency (MHz)	Emission Level (dBuV/m)	Limit (dBuV/m)	Margin (dB)	Antenna Height (m)	Table Angle (Degree)	Raw Value (dBuV)	Correction Factor (dB/m)
1	2378.80	57.4 PK	74.0	-16.6	1.26 H	111	60.0	-2.6
2	2378.80	44.7 AV	54.0	-9.3	1.26 H	111	47.3	-2.6
3	2390.00	56.3 PK	74.0	-17.7	1.26 H	111	59.0	-2.7
4	2390.00	45.3 AV	54.0	-8.7	1.26 H	111	48.0	-2.7
5	*2412.00	104.9 PK			1.26 H	111	107.6	-2.7
6	*2412.00	94.3 AV			1.26 H	111	97.0	-2.7
7	4824.00	44.8 PK	74.0	-29.2	1.04 H	267	43.0	1.8
8	4824.00	42.0 AV	54.0	-12.0	1.04 H	267	40.2	1.8

Antenna Polarity & Test Distance : Vertical at 3 m

No	Frequency (MHz)	Emission Level (dBuV/m)	Limit (dBuV/m)	Margin (dB)	Antenna Height (m)	Table Angle (Degree)	Raw Value (dBuV)	Correction Factor (dB/m)
1	2384.60	61.0 PK	74.0	-13.0	1.71 V	127	63.6	-2.6
2	2384.60	47.1 AV	54.0	-6.9	1.71 V	127	49.7	-2.6
3	2390.00	58.5 PK	74.0	-15.5	1.71 V	127	61.2	-2.7
4	2390.00	48.1 AV	54.0	-5.9	1.71 V	127	50.8	-2.7
5	*2412.00	115.8 PK			1.71 V	127	118.5	-2.7
6	*2412.00	105.0 AV			1.71 V	127	107.7	-2.7
7	4824.00	43.4 PK	74.0	-30.6	1.34 V	88	41.6	1.8
8	4824.00	40.7 AV	54.0	-13.3	1.34 V	88	38.9	1.8

Remarks:

1. Emission Level(dBuV/m) = Raw Value(dBuV) + Correction Factor(dB/m)
2. Correction Factor(dB/m) = Antenna Factor(dB/m) + Cable Factor(dB) – Pre-Amplifier Factor(dB)
3. Margin value = Emission Level – Limit value
4. The other emission levels were very low against the limit.
5. " * ": Fundamental frequency.

RF Mode	TX 802.11ax (HE20)	Channel	CH 6 : 2437 MHz
Frequency Range	1GHz ~ 25GHz	Detector Function	Peak (PK) Average (AV)

Antenna Polarity & Test Distance : Horizontal at 3 m

No	Frequency (MHz)	Emission Level (dBuV/m)	Limit (dBuV/m)	Margin (dB)	Antenna Height (m)	Table Angle (Degree)	Raw Value (dBuV)	Correction Factor (dB/m)
1	2390.00	53.6 PK	74.0	-20.4	1.24 H	109	56.3	-2.7
2	2390.00	40.9 AV	54.0	-13.1	1.24 H	109	43.6	-2.7
3	*2437.00	111.3 PK			1.24 H	109	114.0	-2.7
4	*2437.00	100.6 AV			1.24 H	109	103.3	-2.7
5	2483.50	57.2 PK	74.0	-16.8	1.24 H	109	60.0	-2.8
6	2483.50	41.9 AV	54.0	-12.1	1.24 H	109	44.7	-2.8
7	4874.00	45.0 PK	74.0	-29.0	1.04 H	246	43.3	1.7
8	4874.00	42.5 AV	54.0	-11.5	1.04 H	246	40.8	1.7
9	7311.00	46.8 PK	74.0	-27.2	1.40 H	286	39.6	7.2
10	7311.00	42.0 AV	54.0	-12.0	1.40 H	286	34.8	7.2

Antenna Polarity & Test Distance : Vertical at 3 m

No	Frequency (MHz)	Emission Level (dBuV/m)	Limit (dBuV/m)	Margin (dB)	Antenna Height (m)	Table Angle (Degree)	Raw Value (dBuV)	Correction Factor (dB/m)
1	2390.00	58.6 PK	74.0	-15.4	1.66 V	127	61.3	-2.7
2	2390.00	46.8 AV	54.0	-7.2	1.66 V	127	49.5	-2.7
3	*2437.00	119.4 PK			1.66 V	127	122.1	-2.7
4	*2437.00	110.4 AV			1.66 V	127	113.1	-2.7
5	2483.50	61.9 PK	74.0	-12.1	1.66 V	127	64.7	-2.8
6	2483.50	46.8 AV	54.0	-7.2	1.66 V	127	49.6	-2.8
7	4874.00	44.1 PK	74.0	-29.9	1.25 V	82	42.4	1.7
8	4874.00	41.3 AV	54.0	-12.7	1.25 V	82	39.6	1.7
9	7311.00	51.2 PK	74.0	-22.8	2.71 V	91	44.0	7.2
10	7311.00	47.6 AV	54.0	-6.4	2.71 V	91	40.4	7.2

Remarks:

1. Emission Level(dBuV/m) = Raw Value(dBuV) + Correction Factor(dB/m)
2. Correction Factor(dB/m) = Antenna Factor(dB/m) + Cable Factor(dB) – Pre-Amplifier Factor(dB)
3. Margin value = Emission Level – Limit value
4. The other emission levels were very low against the limit.
5. " * ": Fundamental frequency.

RF Mode	TX 802.11ax (HE20)	Channel	CH 11 : 2462 MHz
Frequency Range	1GHz ~ 25GHz	Detector Function	Peak (PK) Average (AV)

Antenna Polarity & Test Distance : Horizontal at 3 m

No	Frequency (MHz)	Emission Level (dBuV/m)	Limit (dBuV/m)	Margin (dB)	Antenna Height (m)	Table Angle (Degree)	Raw Value (dBuV)	Correction Factor (dB/m)
1	*2462.00	106.3 PK			1.50 H	115	109.1	-2.8
2	*2462.00	95.5 AV			1.50 H	115	98.3	-2.8
3	2483.50	57.2 PK	74.0	-16.8	1.50 H	115	60.0	-2.8
4	2483.50	46.2 AV	54.0	-7.8	1.50 H	115	49.0	-2.8
5	4924.00	45.0 PK	74.0	-29.0	1.03 H	258	43.2	1.8
6	4924.00	42.5 AV	54.0	-11.5	1.03 H	258	40.7	1.8
7	7386.00	46.6 PK	74.0	-27.4	1.40 H	304	39.2	7.4
8	7386.00	41.5 AV	54.0	-12.5	1.40 H	304	34.1	7.4

Antenna Polarity & Test Distance : Vertical at 3 m

No	Frequency (MHz)	Emission Level (dBuV/m)	Limit (dBuV/m)	Margin (dB)	Antenna Height (m)	Table Angle (Degree)	Raw Value (dBuV)	Correction Factor (dB/m)
1	*2462.00	115.6 PK			1.36 V	98	118.4	-2.8
2	*2462.00	104.9 AV			1.36 V	98	107.7	-2.8
3	2483.50	63.2 PK	74.0	-10.8	1.36 V	98	66.0	-2.8
4	2483.50	50.1 AV	54.0	-3.9	1.36 V	98	52.9	-2.8
5	4924.00	43.1 PK	74.0	-30.9	1.23 V	86	41.3	1.8
6	4924.00	40.6 AV	54.0	-13.4	1.23 V	86	38.8	1.8
7	7386.00	51.1 PK	74.0	-22.9	2.68 V	101	43.7	7.4
8	7386.00	47.6 AV	54.0	-6.4	2.68 V	101	40.2	7.4

Remarks:

1. Emission Level(dBuV/m) = Raw Value(dBuV) + Correction Factor(dB/m)
2. Correction Factor(dB/m) = Antenna Factor(dB/m) + Cable Factor(dB) – Pre-Amplifier Factor(dB)
3. Margin value = Emission Level – Limit value
4. The other emission levels were very low against the limit.
5. " * ": Fundamental frequency.

RF Mode	TX 802.11ax (HE20)	Channel	CH 12 : 2467 MHz
Frequency Range	1GHz ~ 25GHz	Detector Function	Peak (PK) Average (AV)

Antenna Polarity & Test Distance : Horizontal at 3 m

No	Frequency (MHz)	Emission Level (dBuV/m)	Limit (dBuV/m)	Margin (dB)	Antenna Height (m)	Table Angle (Degree)	Raw Value (dBuV)	Correction Factor (dB/m)
1	*2467.00	101.9 PK			1.40 H	111	104.7	-2.8
2	*2467.00	92.2 AV			1.40 H	111	95.0	-2.8
3	2489.20	58.3 PK	74.0	-15.7	1.40 H	111	61.1	-2.8
4	2489.20	45.2 AV	54.0	-8.8	1.40 H	111	48.0	-2.8
5	4934.00	44.9 PK	74.0	-29.1	1.00 H	253	43.1	1.8
6	4934.00	41.9 AV	54.0	-12.1	1.00 H	253	40.1	1.8
7	7401.00	46.2 PK	74.0	-27.8	1.42 H	312	38.7	7.5
8	7401.00	41.5 AV	54.0	-12.5	1.42 H	312	34.0	7.5

Antenna Polarity & Test Distance : Vertical at 3 m

No	Frequency (MHz)	Emission Level (dBuV/m)	Limit (dBuV/m)	Margin (dB)	Antenna Height (m)	Table Angle (Degree)	Raw Value (dBuV)	Correction Factor (dB/m)
1	*2467.00	112.5 PK			1.61 V	124	115.3	-2.8
2	*2467.00	101.5 AV			1.61 V	124	104.3	-2.8
3	2483.50	65.5 PK	74.0	-8.5	1.61 V	124	68.3	-2.8
4	2483.50	48.1 AV	54.0	-5.9	1.61 V	124	50.9	-2.8
5	4934.00	43.6 PK	74.0	-30.4	1.29 V	94	41.8	1.8
6	4934.00	40.6 AV	54.0	-13.4	1.29 V	94	38.8	1.8
7	7401.00	51.0 PK	74.0	-23.0	2.67 V	103	43.5	7.5
8	7401.00	47.2 AV	54.0	-6.8	2.67 V	103	39.7	7.5

Remarks:

1. Emission Level(dBuV/m) = Raw Value(dBuV) + Correction Factor(dB/m)
2. Correction Factor(dB/m) = Antenna Factor(dB/m) + Cable Factor(dB) – Pre-Amplifier Factor(dB)
3. Margin value = Emission Level – Limit value
4. The other emission levels were very low against the limit.
5. " * ": Fundamental frequency.

RF Mode	TX 802.11ax (HE20)	Channel	CH 13 : 2472 MHz
Frequency Range	1GHz ~ 25GHz	Detector Function	Peak (PK) Average (AV)

Antenna Polarity & Test Distance : Horizontal at 3 m

No	Frequency (MHz)	Emission Level (dBuV/m)	Limit (dBuV/m)	Margin (dB)	Antenna Height (m)	Table Angle (Degree)	Raw Value (dBuV)	Correction Factor (dB/m)
1	*2472.00	102.3 PK			1.47 H	113	105.1	-2.8
2	*2472.00	91.6 AV			1.47 H	113	94.4	-2.8
3	2483.50	58.3 PK	74.0	-15.7	1.47 H	113	61.1	-2.8
4	2483.50	46.1 AV	54.0	-7.9	1.47 H	113	48.9	-2.8
5	4944.00	45.1 PK	74.0	-28.9	1.05 H	251	43.3	1.8
6	4944.00	42.2 AV	54.0	-11.8	1.05 H	251	40.4	1.8
7	7416.00	47.2 PK	74.0	-26.8	1.45 H	293	39.7	7.5
8	7416.00	42.2 AV	54.0	-11.8	1.45 H	293	34.7	7.5

Antenna Polarity & Test Distance : Vertical at 3 m

No	Frequency (MHz)	Emission Level (dBuV/m)	Limit (dBuV/m)	Margin (dB)	Antenna Height (m)	Table Angle (Degree)	Raw Value (dBuV)	Correction Factor (dB/m)
1	*2472.00	110.6 PK			1.52 V	125	113.4	-2.8
2	*2472.00	100.3 AV			1.52 V	125	103.1	-2.8
3	2483.50	71.5 PK	74.0	-2.5	1.52 V	125	74.3	-2.8
4	2483.50	48.7 AV	54.0	-5.3	1.52 V	125	51.5	-2.8
5	4944.00	43.1 PK	74.0	-30.9	1.24 V	93	41.3	1.8
6	4944.00	40.5 AV	54.0	-13.5	1.24 V	93	38.7	1.8
7	7416.00	51.2 PK	74.0	-22.8	2.65 V	77	43.7	7.5
8	7416.00	47.8 AV	54.0	-6.2	2.65 V	77	40.3	7.5

Remarks:

1. Emission Level(dBuV/m) = Raw Value(dBuV) + Correction Factor(dB/m)
2. Correction Factor(dB/m) = Antenna Factor(dB/m) + Cable Factor(dB) – Pre-Amplifier Factor(dB)
3. Margin value = Emission Level – Limit value
4. The other emission levels were very low against the limit.
5. " * ": Fundamental frequency.

RF Mode	TX 802.11ax (HE40)	Channel	CH 3 : 2422 MHz
Frequency Range	1GHz ~ 25GHz	Detector Function	Peak (PK) Average (AV)

Antenna Polarity & Test Distance : Horizontal at 3 m

No	Frequency (MHz)	Emission Level (dBuV/m)	Limit (dBuV/m)	Margin (dB)	Antenna Height (m)	Table Angle (Degree)	Raw Value (dBuV)	Correction Factor (dB/m)
1	2383.80	57.8 PK	74.0	-16.2	1.43 H	113	60.4	-2.6
2	2383.80	45.3 AV	54.0	-8.7	1.43 H	113	47.9	-2.6
3	*2422.00	101.4 PK			1.43 H	113	104.1	-2.7
4	*2422.00	90.5 AV			1.43 H	113	93.2	-2.7
5	4844.00	44.9 PK	74.0	-29.1	1.01 H	267	43.1	1.8
6	4844.00	42.0 AV	54.0	-12.0	1.01 H	267	40.2	1.8
7	7266.00	47.0 PK	74.0	-27.0	1.39 H	314	39.7	7.3
8	7266.00	42.2 AV	54.0	-11.8	1.39 H	314	34.9	7.3

Antenna Polarity & Test Distance : Vertical at 3 m

No	Frequency (MHz)	Emission Level (dBuV/m)	Limit (dBuV/m)	Margin (dB)	Antenna Height (m)	Table Angle (Degree)	Raw Value (dBuV)	Correction Factor (dB/m)
1	2387.60	61.2 PK	74.0	-12.8	1.55 V	124	63.9	-2.7
2	2387.60	49.3 AV	54.0	-4.7	1.55 V	124	52.0	-2.7
3	*2422.00	111.4 PK			1.55 V	124	114.1	-2.7
4	*2422.00	100.4 AV			1.55 V	124	103.1	-2.7
5	4844.00	44.2 PK	74.0	-29.8	1.25 V	92	42.4	1.8
6	4844.00	41.3 AV	54.0	-12.7	1.25 V	92	39.5	1.8
7	7266.00	51.2 PK	74.0	-22.8	2.73 V	95	43.9	7.3
8	7266.00	47.7 AV	54.0	-6.3	2.73 V	95	40.4	7.3

Remarks:

1. Emission Level(dBuV/m) = Raw Value(dBuV) + Correction Factor(dB/m)
2. Correction Factor(dB/m) = Antenna Factor(dB/m) + Cable Factor(dB) – Pre-Amplifier Factor(dB)
3. Margin value = Emission Level – Limit value
4. The other emission levels were very low against the limit.
5. " * ": Fundamental frequency.

RF Mode	TX 802.11ax (HE40)	Channel	CH 6 : 2437 MHz
Frequency Range	1GHz ~ 25GHz	Detector Function	Peak (PK) Average (AV)

Antenna Polarity & Test Distance : Horizontal at 3 m

No	Frequency (MHz)	Emission Level (dBuV/m)	Limit (dBuV/m)	Margin (dB)	Antenna Height (m)	Table Angle (Degree)	Raw Value (dBuV)	Correction Factor (dB/m)
1	2390.00	63.8 PK	74.0	-10.2	1.41 H	108	66.5	-2.7
2	2390.00	47.6 AV	54.0	-6.4	1.41 H	108	50.3	-2.7
3	*2437.00	104.5 PK			1.41 H	108	107.2	-2.7
4	*2437.00	93.8 AV			1.41 H	108	96.5	-2.7
5	2483.50	68.3 PK	74.0	-5.7	1.41 H	108	71.1	-2.8
6	2483.50	48.2 AV	54.0	-5.8	1.41 H	108	51.0	-2.8
7	4874.00	44.8 PK	74.0	-29.2	1.00 H	260	43.1	1.7
8	4874.00	41.7 AV	54.0	-12.3	1.00 H	260	40.0	1.7
9	7311.00	46.6 PK	74.0	-27.4	1.48 H	309	39.4	7.2
10	7311.00	41.9 AV	54.0	-12.1	1.48 H	309	34.7	7.2

Antenna Polarity & Test Distance : Vertical at 3 m

No	Frequency (MHz)	Emission Level (dBuV/m)	Limit (dBuV/m)	Margin (dB)	Antenna Height (m)	Table Angle (Degree)	Raw Value (dBuV)	Correction Factor (dB/m)
1	2390.00	67.6 PK	74.0	-6.4	1.31 V	100	70.3	-2.7
2	2390.00	51.7 AV	54.0	-2.3	1.31 V	100	54.4	-2.7
3	*2437.00	114.2 PK			1.31 V	100	116.9	-2.7
4	*2437.00	103.1 AV			1.31 V	100	105.8	-2.7
5	2483.50	72.3 PK	74.0	-1.7	1.31 V	100	75.1	-2.8
6	2483.50	52.5 AV	54.0	-1.5	1.31 V	100	55.3	-2.8
7	4874.00	44.1 PK	74.0	-29.9	1.29 V	94	42.4	1.7
8	4874.00	41.2 AV	54.0	-12.8	1.29 V	94	39.5	1.7
9	7311.00	51.6 PK	74.0	-22.4	2.67 V	76	44.4	7.2
10	7311.00	47.6 AV	54.0	-6.4	2.67 V	76	40.4	7.2

Remarks:

1. Emission Level(dBuV/m) = Raw Value(dBuV) + Correction Factor(dB/m)
2. Correction Factor(dB/m) = Antenna Factor(dB/m) + Cable Factor(dB) – Pre-Amplifier Factor(dB)
3. Margin value = Emission Level – Limit value
4. The other emission levels were very low against the limit.
5. " * " : Fundamental frequency.

RF Mode	TX 802.11ax (HE40)	Channel	CH 9 : 2452 MHz
Frequency Range	1GHz ~ 25GHz	Detector Function	Peak (PK) Average (AV)

Antenna Polarity & Test Distance : Horizontal at 3 m

No	Frequency (MHz)	Emission Level (dBuV/m)	Limit (dBuV/m)	Margin (dB)	Antenna Height (m)	Table Angle (Degree)	Raw Value (dBuV)	Correction Factor (dB/m)
1	*2452.00	102.5 PK			1.26 H	113	105.2	-2.7
2	*2452.00	91.4 AV			1.26 H	113	94.1	-2.7
3	2483.50	56.8 PK	74.0	-17.2	1.26 H	113	59.6	-2.8
4	2483.50	46.5 AV	54.0	-7.5	1.26 H	113	49.3	-2.8
5	2487.50	58.1 PK	74.0	-15.9	1.26 H	113	60.9	-2.8
6	2487.50	46.1 AV	54.0	-7.9	1.26 H	113	48.9	-2.8
7	4904.00	45.0 PK	74.0	-29.0	1.04 H	251	43.3	1.7
8	4904.00	42.2 AV	54.0	-11.8	1.04 H	251	40.5	1.7
9	7356.00	46.8 PK	74.0	-27.2	1.42 H	305	39.5	7.3
10	7356.00	41.8 AV	54.0	-12.2	1.42 H	305	34.5	7.3

Antenna Polarity & Test Distance : Vertical at 3 m

No	Frequency (MHz)	Emission Level (dBuV/m)	Limit (dBuV/m)	Margin (dB)	Antenna Height (m)	Table Angle (Degree)	Raw Value (dBuV)	Correction Factor (dB/m)
1	*2452.00	112.1 PK			1.21 V	100	114.8	-2.7
2	*2452.00	100.8 AV			1.21 V	100	103.5	-2.7
3	2483.50	61.8 PK	74.0	-12.2	1.21 V	100	64.6	-2.8
4	2483.50	51.2 AV	54.0	-2.8	1.21 V	100	54.0	-2.8
5	2487.40	64.0 PK	74.0	-10.0	1.21 V	100	66.8	-2.8
6	2487.40	50.6 AV	54.0	-3.4	1.21 V	100	53.4	-2.8
7	4904.00	43.4 PK	74.0	-30.6	1.29 V	76	41.7	1.7
8	4904.00	40.7 AV	54.0	-13.3	1.29 V	76	39.0	1.7
9	7356.00	51.3 PK	74.0	-22.7	2.63 V	84	44.0	7.3
10	7356.00	47.5 AV	54.0	-6.5	2.63 V	84	40.2	7.3

Remarks:

1. Emission Level(dBuV/m) = Raw Value(dBuV) + Correction Factor(dB/m)
2. Correction Factor(dB/m) = Antenna Factor(dB/m) + Cable Factor(dB) – Pre-Amplifier Factor(dB)
3. Margin value = Emission Level – Limit value
4. The other emission levels were very low against the limit.
5. " * ": Fundamental frequency.

RF Mode	TX 802.11ax (HE40)	Channel	CH 10 : 2457 MHz
Frequency Range	1GHz ~ 25GHz	Detector Function	Peak (PK) Average (AV)

Antenna Polarity & Test Distance : Horizontal at 3 m

No	Frequency (MHz)	Emission Level (dBuV/m)	Limit (dBuV/m)	Margin (dB)	Antenna Height (m)	Table Angle (Degree)	Raw Value (dBuV)	Correction Factor (dB/m)
1	*2457.00	99.5 PK			1.51 H	115	102.2	-2.7
2	*2457.00	88.3 AV			1.51 H	115	91.0	-2.7
3	2483.50	55.9 PK	74.0	-18.1	1.51 H	115	58.7	-2.8
4	2483.50	45.7 AV	54.0	-8.3	1.51 H	115	48.5	-2.8
5	2486.90	58.0 PK	74.0	-16.0	1.51 H	115	60.8	-2.8
6	2486.90	45.4 AV	54.0	-8.6	1.51 H	115	48.2	-2.8
7	4914.00	44.8 PK	74.0	-29.2	1.00 H	274	43.1	1.7
8	4914.00	42.2 AV	54.0	-11.8	1.00 H	274	40.5	1.7
9	7371.00	47.0 PK	74.0	-27.0	1.44 H	303	39.7	7.3
10	7371.00	42.3 AV	54.0	-11.7	1.44 H	303	35.0	7.3

Antenna Polarity & Test Distance : Vertical at 3 m

No	Frequency (MHz)	Emission Level (dBuV/m)	Limit (dBuV/m)	Margin (dB)	Antenna Height (m)	Table Angle (Degree)	Raw Value (dBuV)	Correction Factor (dB/m)
1	*2457.00	108.8 PK			1.58 V	129	111.5	-2.7
2	*2457.00	97.6 AV			1.58 V	129	100.3	-2.7
3	2483.50	58.4 PK	74.0	-15.6	1.58 V	129	61.2	-2.8
4	2483.50	47.8 AV	54.0	-6.2	1.58 V	129	50.6	-2.8
5	2495.00	60.0 PK	74.0	-14.0	1.58 V	129	62.8	-2.8
6	2495.00	47.2 AV	54.0	-6.8	1.58 V	129	50.0	-2.8
7	4914.00	43.3 PK	74.0	-30.7	1.30 V	94	41.6	1.7
8	4914.00	40.5 AV	54.0	-13.5	1.30 V	94	38.8	1.7
9	7371.00	50.8 PK	74.0	-23.2	2.67 V	98	43.5	7.3
10	7371.00	47.2 AV	54.0	-6.8	2.67 V	98	39.9	7.3

Remarks:

1. Emission Level(dBuV/m) = Raw Value(dBuV) + Correction Factor(dB/m)
2. Correction Factor(dB/m) = Antenna Factor(dB/m) + Cable Factor(dB) – Pre-Amplifier Factor(dB)
3. Margin value = Emission Level – Limit value
4. The other emission levels were very low against the limit.
5. " * ": Fundamental frequency.

RF Mode	TX 802.11ax (HE40)	Channel	CH 11 : 2462 MHz
Frequency Range	1GHz ~ 25GHz	Detector Function	Peak (PK) Average (AV)

Antenna Polarity & Test Distance : Horizontal at 3 m

No	Frequency (MHz)	Emission Level (dBuV/m)	Limit (dBuV/m)	Margin (dB)	Antenna Height (m)	Table Angle (Degree)	Raw Value (dBuV)	Correction Factor (dB/m)
1	*2462.00	99.2 PK			1.54 H	114	102.0	-2.8
2	*2462.00	87.6 AV			1.54 H	114	90.4	-2.8
3	2483.50	56.3 PK	74.0	-17.7	1.54 H	114	59.1	-2.8
4	2483.50	45.4 AV	54.0	-8.6	1.54 H	114	48.2	-2.8
5	4924.00	44.4 PK	74.0	-29.6	1.01 H	251	42.6	1.8
6	4924.00	41.7 AV	54.0	-12.3	1.01 H	251	39.9	1.8
7	7386.00	46.9 PK	74.0	-27.1	1.41 H	308	39.5	7.4
8	7386.00	42.0 AV	54.0	-12.0	1.41 H	308	34.6	7.4

Antenna Polarity & Test Distance : Vertical at 3 m

No	Frequency (MHz)	Emission Level (dBuV/m)	Limit (dBuV/m)	Margin (dB)	Antenna Height (m)	Table Angle (Degree)	Raw Value (dBuV)	Correction Factor (dB/m)
1	*2462.00	108.0 PK			1.68 V	122	110.8	-2.8
2	*2462.00	96.6 AV			1.68 V	122	99.4	-2.8
3	2483.50	59.6 PK	74.0	-14.4	1.68 V	122	62.4	-2.8
4	2483.50	47.7 AV	54.0	-6.3	1.68 V	122	50.5	-2.8
5	4924.00	42.9 PK	74.0	-31.1	1.31 V	98	41.1	1.8
6	4924.00	40.4 AV	54.0	-13.6	1.31 V	98	38.6	1.8
7	7386.00	51.2 PK	74.0	-22.8	2.64 V	94	43.8	7.4
8	7386.00	47.6 AV	54.0	-6.4	2.64 V	94	40.2	7.4

Remarks:

1. Emission Level(dBuV/m) = Raw Value(dBuV) + Correction Factor(dB/m)
2. Correction Factor(dB/m) = Antenna Factor(dB/m) + Cable Factor(dB) – Pre-Amplifier Factor(dB)
3. Margin value = Emission Level – Limit value
4. The other emission levels were very low against the limit.
5. " * ": Fundamental frequency.

RF Mode	TX 20MHz Preamble 802.11ax (RU26)	Channel	CH 1 : 2412 MHz
Frequency Range	1GHz ~ 25GHz	Detector Function	Peak (PK) Average (AV)

Antenna Polarity & Test Distance : Horizontal at 3 m

No	Frequency (MHz)	Emission Level (dBuV/m)	Limit (dBuV/m)	Margin (dB)	Antenna Height (m)	Table Angle (Degree)	Raw Value (dBuV)	Correction Factor (dB/m)
1	2388.71	64.9 PK	74.0	-9.1	1.00 H	112	67.6	-2.7
2	2388.71	43.9 AV	54.0	-10.1	1.00 H	112	46.6	-2.7
3	*2412.00	113.9 PK			1.00 H	112	116.6	-2.7
4	*2412.00	102.2 AV			1.00 H	112	104.9	-2.7
5	4824.00	44.3 PK	74.0	-29.7	1.31 H	283	42.5	1.8
6	4824.00	33.1 AV	54.0	-20.9	1.31 H	283	31.3	1.8

Antenna Polarity & Test Distance : Vertical at 3 m

No	Frequency (MHz)	Emission Level (dBuV/m)	Limit (dBuV/m)	Margin (dB)	Antenna Height (m)	Table Angle (Degree)	Raw Value (dBuV)	Correction Factor (dB/m)
1	2387.62	72.3 PK	74.0	-1.7	1.22 V	22	75.0	-2.7
2	2387.62	46.0 AV	54.0	-8.0	1.22 V	22	48.7	-2.7
3	*2412.00	123.4 PK			1.22 V	22	126.1	-2.7
4	*2412.00	111.0 AV			1.22 V	22	113.7	-2.7
5	4824.00	47.7 PK	74.0	-26.3	1.22 V	86	45.9	1.8
6	4824.00	36.5 AV	54.0	-17.5	1.22 V	86	34.7	1.8

Remarks:

1. Emission Level(dBuV/m) = Raw Value(dBuV) + Correction Factor(dB/m)
2. Correction Factor(dB/m) = Antenna Factor(dB/m) + Cable Factor(dB) – Pre-Amplifier Factor(dB)
3. Margin value = Emission Level – Limit value
4. The other emission levels were very low against the limit.
5. " * " : Fundamental frequency.

RF Mode	TX 20MHz Preamble 802.11ax (RU26)	Channel	CH 6 : 2437 MHz
Frequency Range	1GHz ~ 25GHz	Detector Function	Peak (PK) Average (AV)

Antenna Polarity & Test Distance : Horizontal at 3 m

No	Frequency (MHz)	Emission Level (dBuV/m)	Limit (dBuV/m)	Margin (dB)	Antenna Height (m)	Table Angle (Degree)	Raw Value (dBuV)	Correction Factor (dB/m)
1	2390.00	55.1 PK	74.0	-18.9	1.03 H	113	57.8	-2.7
2	2390.00	43.1 AV	54.0	-10.9	1.03 H	113	45.8	-2.7
3	*2437.00	116.9 PK			1.03 H	113	119.6	-2.7
4	*2437.00	105.6 AV			1.03 H	113	108.3	-2.7
5	2483.50	56.3 PK	74.0	-17.7	1.03 H	113	59.1	-2.8
6	2483.50	43.7 AV	54.0	-10.3	1.03 H	113	46.5	-2.8
7	4874.00	44.5 PK	74.0	-29.5	1.33 H	267	42.8	1.7
8	4874.00	33.4 AV	54.0	-20.6	1.33 H	267	31.7	1.7
9	7311.00	63.4 PK	74.0	-10.6	1.11 H	304	56.2	7.2
10	7311.00	47.1 AV	54.0	-6.9	1.11 H	304	39.9	7.2

Antenna Polarity & Test Distance : Vertical at 3 m

No	Frequency (MHz)	Emission Level (dBuV/m)	Limit (dBuV/m)	Margin (dB)	Antenna Height (m)	Table Angle (Degree)	Raw Value (dBuV)	Correction Factor (dB/m)
1	2390.00	56.6 PK	74.0	-17.4	1.26 V	20	59.3	-2.7
2	2390.00	44.0 AV	54.0	-10.0	1.26 V	20	46.7	-2.7
3	*2437.00	126.3 PK			1.26 V	20	129.0	-2.7
4	*2437.00	115.8 AV			1.26 V	20	118.5	-2.7
5	2483.50	57.9 PK	74.0	-16.1	1.26 V	20	60.7	-2.8
6	2483.50	44.1 AV	54.0	-9.9	1.26 V	20	46.9	-2.8
7	4874.00	47.2 PK	74.0	-26.8	1.27 V	91	45.5	1.7
8	4874.00	35.0 AV	54.0	-19.0	1.27 V	91	33.3	1.7
9	7311.00	67.1 PK	74.0	-6.9	1.25 V	48	59.9	7.2
10	7311.00	50.9 AV	54.0	-3.1	1.25 V	48	43.7	7.2

Remarks:

1. Emission Level(dBuV/m) = Raw Value(dBuV) + Correction Factor(dB/m)
2. Correction Factor(dB/m) = Antenna Factor(dB/m) + Cable Factor(dB) – Pre-Amplifier Factor(dB)
3. Margin value = Emission Level – Limit value
4. The other emission levels were very low against the limit.
5. " * " : Fundamental frequency.

RF Mode	TX 20MHz Preamble 802.11ax (RU26)	Channel	CH 11 : 2462 MHz
Frequency Range	1GHz ~ 25GHz	Detector Function	Peak (PK) Average (AV)

Antenna Polarity & Test Distance : Horizontal at 3 m

No	Frequency (MHz)	Emission Level (dBuV/m)	Limit (dBuV/m)	Margin (dB)	Antenna Height (m)	Table Angle (Degree)	Raw Value (dBuV)	Correction Factor (dB/m)
1	*2462.00	112.9 PK			1.19 H	109	115.7	-2.8
2	*2462.00	101.3 AV			1.19 H	109	104.1	-2.8
3	2483.90	65.6 PK	74.0	-8.4	1.19 H	109	68.4	-2.8
4	2483.90	43.2 AV	54.0	-10.8	1.19 H	109	46.0	-2.8
5	4924.00	44.7 PK	74.0	-29.3	1.33 H	274	42.9	1.8
6	4924.00	33.8 AV	54.0	-20.2	1.33 H	274	32.0	1.8
7	7386.00	59.4 PK	74.0	-14.6	1.10 H	295	52.0	7.4
8	7386.00	44.3 AV	54.0	-9.7	1.10 H	295	36.9	7.4

Antenna Polarity & Test Distance : Vertical at 3 m

No	Frequency (MHz)	Emission Level (dBuV/m)	Limit (dBuV/m)	Margin (dB)	Antenna Height (m)	Table Angle (Degree)	Raw Value (dBuV)	Correction Factor (dB/m)
1	*2462.00	124.0 PK			1.51 V	285	126.8	-2.8
2	*2462.00	111.1 AV			1.51 V	285	113.9	-2.8
3	2483.50	72.3 PK	74.0	-1.7	1.51 V	285	75.1	-2.8
4	2483.50	45.6 AV	54.0	-8.4	1.51 V	285	48.4	-2.8
5	4924.00	47.0 PK	74.0	-27.0	1.27 V	92	45.2	1.8
6	4924.00	36.0 AV	54.0	-18.0	1.27 V	92	34.2	1.8
7	7386.00	66.1 PK	74.0	-7.9	1.27 V	58	58.7	7.4
8	7386.00	47.9 AV	54.0	-6.1	1.27 V	58	40.5	7.4

Remarks:

1. Emission Level(dBuV/m) = Raw Value(dBuV) + Correction Factor(dB/m)
2. Correction Factor(dB/m) = Antenna Factor(dB/m) + Cable Factor(dB) – Pre-Amplifier Factor(dB)
3. Margin value = Emission Level – Limit value
4. The other emission levels were very low against the limit.
5. " * ": Fundamental frequency.

RF Mode	TX 20MHz Preamble 802.11ax (RU26)	Channel	CH 12 : 2467 MHz
Frequency Range	1GHz ~ 25GHz	Detector Function	Peak (PK) Average (AV)

Antenna Polarity & Test Distance : Horizontal at 3 m

No	Frequency (MHz)	Emission Level (dBuV/m)	Limit (dBuV/m)	Margin (dB)	Antenna Height (m)	Table Angle (Degree)	Raw Value (dBuV)	Correction Factor (dB/m)
1	*2467.00	109.5 PK			1.15 H	104	112.3	-2.8
2	*2467.00	99.3 AV			1.15 H	104	102.1	-2.8
3	2484.00	69.3 PK	74.0	-4.7	1.15 H	104	72.1	-2.8
4	2484.00	43.1 AV	54.0	-10.9	1.15 H	104	45.9	-2.8
5	4934.00	44.9 PK	74.0	-29.1	1.38 H	264	43.1	1.8
6	4934.00	33.6 AV	54.0	-20.4	1.38 H	264	31.8	1.8
7	7401.00	63.7 PK	74.0	-10.3	1.12 H	318	56.2	7.5
8	7401.00	47.4 AV	54.0	-6.6	1.12 H	318	39.9	7.5

Antenna Polarity & Test Distance : Vertical at 3 m

No	Frequency (MHz)	Emission Level (dBuV/m)	Limit (dBuV/m)	Margin (dB)	Antenna Height (m)	Table Angle (Degree)	Raw Value (dBuV)	Correction Factor (dB/m)
1	*2467.00	119.9 PK			1.50 V	283	122.7	-2.8
2	*2467.00	108.0 AV			1.50 V	283	110.8	-2.8
3	2485.36	72.5 PK	74.0	-1.5	1.50 V	283	75.3	-2.8
4	2485.36	46.1 AV	54.0	-7.9	1.50 V	283	48.9	-2.8
5	4934.00	47.5 PK	74.0	-26.5	1.27 V	101	45.7	1.8
6	4934.00	36.5 AV	54.0	-17.5	1.27 V	101	34.7	1.8
7	7401.00	66.4 PK	74.0	-7.6	1.21 V	62	58.9	7.5
8	7401.00	48.3 AV	54.0	-5.7	1.21 V	62	40.8	7.5

Remarks:

1. Emission Level(dBuV/m) = Raw Value(dBuV) + Correction Factor(dB/m)
2. Correction Factor(dB/m) = Antenna Factor(dB/m) + Cable Factor(dB) – Pre-Amplifier Factor(dB)
3. Margin value = Emission Level – Limit value
4. The other emission levels were very low against the limit.
5. " * ": Fundamental frequency.

RF Mode	TX 20MHz Preamble 802.11ax (RU26)	Channel	CH 13 : 2472 MHz
Frequency Range	1GHz ~ 25GHz	Detector Function	Peak (PK) Average (AV)

Antenna Polarity & Test Distance : Horizontal at 3 m

No	Frequency (MHz)	Emission Level (dBuV/m)	Limit (dBuV/m)	Margin (dB)	Antenna Height (m)	Table Angle (Degree)	Raw Value (dBuV)	Correction Factor (dB/m)
1	*2472.00	104.2 PK			1.13 H	100	107.0	-2.8
2	*2472.00	91.9 AV			1.13 H	100	94.7	-2.8
3	2484.91	58.2 PK	74.0	-15.8	1.13 H	100	61.0	-2.8
4	2484.91	43.3 AV	54.0	-10.7	1.13 H	100	46.1	-2.8
5	4944.00	44.5 PK	74.0	-29.5	1.38 H	275	42.7	1.8
6	4944.00	33.4 AV	54.0	-20.6	1.38 H	275	31.6	1.8
7	7416.00	63.3 PK	74.0	-10.7	1.06 H	310	55.8	7.5
8	7416.00	47.2 AV	54.0	-6.8	1.06 H	310	39.7	7.5

Antenna Polarity & Test Distance : Vertical at 3 m

No	Frequency (MHz)	Emission Level (dBuV/m)	Limit (dBuV/m)	Margin (dB)	Antenna Height (m)	Table Angle (Degree)	Raw Value (dBuV)	Correction Factor (dB/m)
1	*2472.00	115.2 PK			1.76 V	149	118.0	-2.8
2	*2472.00	103.5 AV			1.76 V	149	106.3	-2.8
3	2483.50	72.5 PK	74.0	-1.5	1.76 V	149	75.3	-2.8
4	2483.50	47.5 AV	54.0	-6.5	1.76 V	149	50.3	-2.8
5	4944.00	47.1 PK	74.0	-26.9	1.22 V	85	45.3	1.8
6	4944.00	36.1 AV	54.0	-17.9	1.22 V	85	34.3	1.8
7	7416.00	66.6 PK	74.0	-7.4	1.23 V	44	59.1	7.5
8	7416.00	48.2 AV	54.0	-5.8	1.23 V	44	40.7	7.5

Remarks:

1. Emission Level(dBuV/m) = Raw Value(dBuV) + Correction Factor(dB/m)
2. Correction Factor(dB/m) = Antenna Factor(dB/m) + Cable Factor(dB) – Pre-Amplifier Factor(dB)
3. Margin value = Emission Level – Limit value
4. The other emission levels were very low against the limit.
5. " * ": Fundamental frequency.

RF Mode	TX 20MHz Preamble 802.11ax (RU52)	Channel	CH 1 : 2412 MHz
Frequency Range	1GHz ~ 25GHz	Detector Function	Peak (PK) Average (AV)

Antenna Polarity & Test Distance : Horizontal at 3 m

No	Frequency (MHz)	Emission Level (dBuV/m)	Limit (dBuV/m)	Margin (dB)	Antenna Height (m)	Table Angle (Degree)	Raw Value (dBuV)	Correction Factor (dB/m)
1	2388.00	64.5 PK	74.0	-9.5	1.05 H	116	67.2	-2.7
2	2388.00	44.2 AV	54.0	-9.8	1.05 H	116	46.9	-2.7
3	*2412.00	113.3 PK			1.05 H	116	116.0	-2.7
4	*2412.00	101.3 AV			1.05 H	116	104.0	-2.7
5	4824.00	44.4 PK	74.0	-29.6	1.36 H	254	42.6	1.8
6	4824.00	33.1 AV	54.0	-20.9	1.36 H	254	31.3	1.8

Antenna Polarity & Test Distance : Vertical at 3 m

No	Frequency (MHz)	Emission Level (dBuV/m)	Limit (dBuV/m)	Margin (dB)	Antenna Height (m)	Table Angle (Degree)	Raw Value (dBuV)	Correction Factor (dB/m)
1	2363.30	60.1 PK	74.0	-13.9	1.25 V	26	62.8	-2.7
2	2363.30	47.7 AV	54.0	-6.3	1.25 V	26	50.4	-2.7
3	2387.76	72.4 PK	74.0	-1.6	1.25 V	26	75.1	-2.7
4	2387.76	46.8 AV	54.0	-7.2	1.25 V	26	49.5	-2.7
5	*2412.00	123.4 PK			1.25 V	26	126.1	-2.7
6	*2412.00	111.9 AV			1.25 V	26	114.6	-2.7
7	4824.00	47.9 PK	74.0	-26.1	1.21 V	75	46.1	1.8
8	4824.00	36.5 AV	54.0	-17.5	1.21 V	75	34.7	1.8

Remarks:

1. Emission Level(dBuV/m) = Raw Value(dBuV) + Correction Factor(dB/m)
2. Correction Factor(dB/m) = Antenna Factor(dB/m) + Cable Factor(dB) – Pre-Amplifier Factor(dB)
3. Margin value = Emission Level – Limit value
4. The other emission levels were very low against the limit.
5. " * ": Fundamental frequency.

RF Mode	TX 20MHz Preamble 802.11ax (RU52)	Channel	CH 6 : 2437 MHz
Frequency Range	1GHz ~ 25GHz	Detector Function	Peak (PK) Average (AV)

Antenna Polarity & Test Distance : Horizontal at 3 m

No	Frequency (MHz)	Emission Level (dBuV/m)	Limit (dBuV/m)	Margin (dB)	Antenna Height (m)	Table Angle (Degree)	Raw Value (dBuV)	Correction Factor (dB/m)
1	2390.00	55.0 PK	74.0	-19.0	1.09 H	114	57.7	-2.7
2	2390.00	42.8 AV	54.0	-11.2	1.09 H	114	45.5	-2.7
3	*2437.00	116.4 PK			1.09 H	114	119.1	-2.7
4	*2437.00	104.1 AV			1.09 H	114	106.8	-2.7
5	2483.50	56.6 PK	74.0	-17.4	1.09 H	114	59.4	-2.8
6	2483.50	44.1 AV	54.0	-9.9	1.09 H	114	46.9	-2.8
7	4874.00	43.9 PK	74.0	-30.1	1.27 H	270	42.2	1.7
8	4874.00	31.6 AV	54.0	-22.4	1.27 H	270	29.9	1.7
9	7311.00	61.9 PK	74.0	-12.1	1.14 H	299	54.7	7.2
10	7311.00	46.8 AV	54.0	-7.2	1.14 H	299	39.6	7.2

Antenna Polarity & Test Distance : Vertical at 3 m

No	Frequency (MHz)	Emission Level (dBuV/m)	Limit (dBuV/m)	Margin (dB)	Antenna Height (m)	Table Angle (Degree)	Raw Value (dBuV)	Correction Factor (dB/m)
1	2390.00	57.3 PK	74.0	-16.7	1.29 V	23	60.0	-2.7
2	2390.00	45.2 AV	54.0	-8.8	1.29 V	23	47.9	-2.7
3	*2437.00	125.0 PK			1.29 V	23	127.7	-2.7
4	*2437.00	114.3 AV			1.29 V	23	117.0	-2.7
5	2483.50	58.1 PK	74.0	-15.9	1.29 V	23	60.9	-2.8
6	2483.50	45.3 AV	54.0	-8.7	1.29 V	23	48.1	-2.8
7	4874.00	45.0 PK	74.0	-29.0	1.26 V	98	43.3	1.7
8	4874.00	33.0 AV	54.0	-21.0	1.26 V	98	31.3	1.7
9	7311.00	65.5 PK	74.0	-8.5	2.77 V	49	58.3	7.2
10	7311.00	50.3 AV	54.0	-3.7	2.77 V	49	43.1	7.2

Remarks:

1. Emission Level(dBuV/m) = Raw Value(dBuV) + Correction Factor(dB/m)
2. Correction Factor(dB/m) = Antenna Factor(dB/m) + Cable Factor(dB) – Pre-Amplifier Factor(dB)
3. Margin value = Emission Level – Limit value
4. The other emission levels were very low against the limit.
5. " * ": Fundamental frequency.

RF Mode	TX 20MHz Preamble 802.11ax (RU52)	Channel	CH 11 : 2462 MHz
Frequency Range	1GHz ~ 25GHz	Detector Function	Peak (PK) Average (AV)

Antenna Polarity & Test Distance : Horizontal at 3 m

No	Frequency (MHz)	Emission Level (dBuV/m)	Limit (dBuV/m)	Margin (dB)	Antenna Height (m)	Table Angle (Degree)	Raw Value (dBuV)	Correction Factor (dB/m)
1	*2462.00	112.9 PK			1.17 H	111	115.7	-2.8
2	*2462.00	100.8 AV			1.17 H	111	103.6	-2.8
3	2484.12	61.1 PK	74.0	-12.9	1.17 H	111	63.9	-2.8
4	2484.12	43.7 AV	54.0	-10.3	1.17 H	111	46.5	-2.8
5	4924.00	44.6 PK	74.0	-29.4	1.37 H	266	42.8	1.8
6	4924.00	33.6 AV	54.0	-20.4	1.37 H	266	31.8	1.8
7	7386.00	63.0 PK	74.0	-11.0	1.07 H	301	55.6	7.4
8	7386.00	46.8 AV	54.0	-7.2	1.07 H	301	39.4	7.4

Antenna Polarity & Test Distance : Vertical at 3 m

No	Frequency (MHz)	Emission Level (dBuV/m)	Limit (dBuV/m)	Margin (dB)	Antenna Height (m)	Table Angle (Degree)	Raw Value (dBuV)	Correction Factor (dB/m)
1	*2462.00	122.6 PK			1.53 V	294	125.4	-2.8
2	*2462.00	111.2 AV			1.53 V	294	114.0	-2.8
3	2483.50	72.5 PK	74.0	-1.5	1.53 V	294	75.3	-2.8
4	2483.50	47.7 AV	54.0	-6.3	1.53 V	294	50.5	-2.8
5	4924.00	47.0 PK	74.0	-27.0	1.25 V	99	45.2	1.8
6	4924.00	35.8 AV	54.0	-18.2	1.25 V	99	34.0	1.8
7	7386.00	66.3 PK	74.0	-7.7	1.23 V	62	58.9	7.4
8	7386.00	48.3 AV	54.0	-5.7	1.23 V	62	40.9	7.4

Remarks:

1. Emission Level(dBuV/m) = Raw Value(dBuV) + Correction Factor(dB/m)
2. Correction Factor(dB/m) = Antenna Factor(dB/m) + Cable Factor(dB) – Pre-Amplifier Factor(dB)
3. Margin value = Emission Level – Limit value
4. The other emission levels were very low against the limit.
5. " * ": Fundamental frequency.

RF Mode	TX 20MHz Preamble 802.11ax (RU52)	Channel	CH 12 : 2467 MHz
Frequency Range	1GHz ~ 25GHz	Detector Function	Peak (PK) Average (AV)

Antenna Polarity & Test Distance : Horizontal at 3 m

No	Frequency (MHz)	Emission Level (dBuV/m)	Limit (dBuV/m)	Margin (dB)	Antenna Height (m)	Table Angle (Degree)	Raw Value (dBuV)	Correction Factor (dB/m)
1	*2467.00	106.8 PK			1.15 H	109	109.6	-2.8
2	*2467.00	94.8 AV			1.15 H	109	97.6	-2.8
3	2483.50	58.9 PK	74.0	-15.1	1.15 H	109	61.7	-2.8
4	2483.50	43.1 AV	54.0	-10.9	1.15 H	109	45.9	-2.8
5	4934.00	44.0 PK	74.0	-30.0	1.36 H	271	42.2	1.8
6	4934.00	33.1 AV	54.0	-20.9	1.36 H	271	31.3	1.8
7	7401.00	63.5 PK	74.0	-10.5	1.11 H	312	56.0	7.5
8	7401.00	47.0 AV	54.0	-7.0	1.11 H	312	39.5	7.5

Antenna Polarity & Test Distance : Vertical at 3 m

No	Frequency (MHz)	Emission Level (dBuV/m)	Limit (dBuV/m)	Margin (dB)	Antenna Height (m)	Table Angle (Degree)	Raw Value (dBuV)	Correction Factor (dB/m)
1	*2467.00	118.3 PK			1.58 V	280	121.1	-2.8
2	*2467.00	106.9 AV			1.58 V	280	109.7	-2.8
3	2483.63	72.3 PK	74.0	-1.7	1.58 V	280	75.1	-2.8
4	2483.63	47.3 AV	54.0	-6.7	1.58 V	280	50.1	-2.8
5	4934.00	46.9 PK	74.0	-27.1	1.27 V	86	45.1	1.8
6	4934.00	35.9 AV	54.0	-18.1	1.27 V	86	34.1	1.8
7	7401.00	66.7 PK	74.0	-7.3	1.27 V	69	59.2	7.5
8	7401.00	48.2 AV	54.0	-5.8	1.27 V	69	40.7	7.5

Remarks:

1. Emission Level(dBuV/m) = Raw Value(dBuV) + Correction Factor(dB/m)
2. Correction Factor(dB/m) = Antenna Factor(dB/m) + Cable Factor(dB) – Pre-Amplifier Factor(dB)
3. Margin value = Emission Level – Limit value
4. The other emission levels were very low against the limit.
5. " * ": Fundamental frequency.

RF Mode	TX 20MHz Preamble 802.11ax (RU52)	Channel	CH 13 : 2472 MHz
Frequency Range	1GHz ~ 25GHz	Detector Function	Peak (PK) Average (AV)

Antenna Polarity & Test Distance : Horizontal at 3 m

No	Frequency (MHz)	Emission Level (dBuV/m)	Limit (dBuV/m)	Margin (dB)	Antenna Height (m)	Table Angle (Degree)	Raw Value (dBuV)	Correction Factor (dB/m)
1	*2472.00	102.3 PK			1.10 H	103	105.1	-2.8
2	*2472.00	92.0 AV			1.10 H	103	94.8	-2.8
3	2484.53	61.5 PK	74.0	-12.5	1.10 H	103	64.3	-2.8
4	2484.53	43.2 AV	54.0	-10.8	1.10 H	103	46.0	-2.8
5	4944.00	44.3 PK	74.0	-29.7	1.27 H	279	42.5	1.8
6	4944.00	33.2 AV	54.0	-20.8	1.27 H	279	31.4	1.8
7	7416.00	63.7 PK	74.0	-10.3	1.06 H	318	56.2	7.5
8	7416.00	47.1 AV	54.0	-6.9	1.06 H	318	39.6	7.5

Antenna Polarity & Test Distance : Vertical at 3 m

No	Frequency (MHz)	Emission Level (dBuV/m)	Limit (dBuV/m)	Margin (dB)	Antenna Height (m)	Table Angle (Degree)	Raw Value (dBuV)	Correction Factor (dB/m)
1	*2472.00	114.6 PK			1.67 V	139	117.4	-2.8
2	*2472.00	103.8 AV			1.67 V	139	106.6	-2.8
3	2483.50	72.0 PK	74.0	-2.0	1.67 V	139	74.8	-2.8
4	2483.50	49.3 AV	54.0	-4.7	1.67 V	139	52.1	-2.8
5	4944.00	47.5 PK	74.0	-26.5	1.23 V	95	45.7	1.8
6	4944.00	36.2 AV	54.0	-17.8	1.23 V	95	34.4	1.8
7	7416.00	66.5 PK	74.0	-7.5	1.30 V	56	59.0	7.5
8	7416.00	48.2 AV	54.0	-5.8	1.30 V	56	40.7	7.5

Remarks:

1. Emission Level(dBuV/m) = Raw Value(dBuV) + Correction Factor(dB/m)
2. Correction Factor(dB/m) = Antenna Factor(dB/m) + Cable Factor(dB) – Pre-Amplifier Factor(dB)
3. Margin value = Emission Level – Limit value
4. The other emission levels were very low against the limit.
5. " * ": Fundamental frequency.

RF Mode	TX 20MHz Preamble 802.11ax (RU106)	Channel	CH 1 : 2412 MHz
Frequency Range	1GHz ~ 25GHz	Detector Function	Peak (PK) Average (AV)

Antenna Polarity & Test Distance : Horizontal at 3 m

No	Frequency (MHz)	Emission Level (dBuV/m)	Limit (dBuV/m)	Margin (dB)	Antenna Height (m)	Table Angle (Degree)	Raw Value (dBuV)	Correction Factor (dB/m)
1	2390.00	64.4 PK	74.0	-9.6	1.11 H	115	67.1	-2.7
2	2390.00	45.3 AV	54.0	-8.7	1.11 H	115	48.0	-2.7
3	*2412.00	111.2 PK			1.11 H	115	113.9	-2.7
4	*2412.00	99.9 AV			1.11 H	115	102.6	-2.7
5	4824.00	44.7 PK	74.0	-29.3	1.33 H	262	42.9	1.8
6	4824.00	33.8 AV	54.0	-20.2	1.33 H	262	32.0	1.8

Antenna Polarity & Test Distance : Vertical at 3 m

No	Frequency (MHz)	Emission Level (dBuV/m)	Limit (dBuV/m)	Margin (dB)	Antenna Height (m)	Table Angle (Degree)	Raw Value (dBuV)	Correction Factor (dB/m)
1	2387.90	72.4 PK	74.0	-1.6	1.46 V	247	75.1	-2.7
2	2387.90	48.5 AV	54.0	-5.5	1.46 V	247	51.2	-2.7
3	2390.00	71.5 PK	74.0	-2.5	1.46 V	247	74.2	-2.7
4	2390.00	49.8 AV	54.0	-4.2	1.46 V	247	52.5	-2.7
5	*2412.00	120.8 PK			1.46 V	247	123.5	-2.7
6	*2412.00	109.6 AV			1.46 V	247	112.3	-2.7
7	4824.00	47.6 PK	74.0	-26.4	1.27 V	74	45.8	1.8
8	4824.00	36.4 AV	54.0	-17.6	1.27 V	74	34.6	1.8

Remarks:

1. Emission Level(dBuV/m) = Raw Value(dBuV) + Correction Factor(dB/m)
2. Correction Factor(dB/m) = Antenna Factor(dB/m) + Cable Factor(dB) – Pre-Amplifier Factor(dB)
3. Margin value = Emission Level – Limit value
4. The other emission levels were very low against the limit.
5. " * " : Fundamental frequency.

RF Mode	TX 20MHz Preamble 802.11ax (RU106)	Channel	CH 6 : 2437 MHz
Frequency Range	1GHz ~ 25GHz	Detector Function	Peak (PK) Average (AV)

Antenna Polarity & Test Distance : Horizontal at 3 m

No	Frequency (MHz)	Emission Level (dBuV/m)	Limit (dBuV/m)	Margin (dB)	Antenna Height (m)	Table Angle (Degree)	Raw Value (dBuV)	Correction Factor (dB/m)
1	2390.00	55.4 PK	74.0	-18.6	1.10 H	115	58.1	-2.7
2	2390.00	43.1 AV	54.0	-10.9	1.10 H	115	45.8	-2.7
3	*2437.00	114.3 PK			1.10 H	115	117.0	-2.7
4	*2437.00	102.1 AV			1.10 H	115	104.8	-2.7
5	2483.50	56.4 PK	74.0	-17.6	1.10 H	115	59.2	-2.8
6	2483.50	43.8 AV	54.0	-10.2	1.10 H	115	46.6	-2.8
7	4874.00	43.7 PK	74.0	-30.3	1.39 H	267	42.0	1.7
8	4874.00	30.2 AV	54.0	-23.8	1.39 H	267	28.5	1.7
9	7311.00	59.1 PK	74.0	-14.9	1.11 H	319	51.9	7.2
10	7311.00	45.1 AV	54.0	-8.9	1.11 H	319	37.9	7.2

Antenna Polarity & Test Distance : Vertical at 3 m

No	Frequency (MHz)	Emission Level (dBuV/m)	Limit (dBuV/m)	Margin (dB)	Antenna Height (m)	Table Angle (Degree)	Raw Value (dBuV)	Correction Factor (dB/m)
1	2390.00	59.0 PK	74.0	-15.0	1.50 V	238	61.7	-2.7
2	2390.00	45.9 AV	54.0	-8.1	1.50 V	238	48.6	-2.7
3	*2437.00	123.6 PK			1.50 V	238	126.3	-2.7
4	*2437.00	112.8 AV			1.50 V	238	115.5	-2.7
5	2483.50	66.8 PK	74.0	-7.2	1.50 V	238	69.6	-2.8
6	2483.50	46.7 AV	54.0	-7.3	1.50 V	238	49.5	-2.8
7	4874.00	47.6 PK	74.0	-26.4	1.24 V	89	45.9	1.7
8	4874.00	36.7 AV	54.0	-17.3	1.24 V	89	35.0	1.7
9	7311.00	63.7 PK	74.0	-10.3	1.27 V	51	56.5	7.2
10	7311.00	49.2 AV	54.0	-4.8	1.27 V	51	42.0	7.2

Remarks:

1. Emission Level(dBuV/m) = Raw Value(dBuV) + Correction Factor(dB/m)
2. Correction Factor(dB/m) = Antenna Factor(dB/m) + Cable Factor(dB) – Pre-Amplifier Factor(dB)
3. Margin value = Emission Level – Limit value
4. The other emission levels were very low against the limit.
5. " * " : Fundamental frequency.

RF Mode	TX 20MHz Preamble 802.11ax (RU106)	Channel	CH 11 : 2462 MHz
Frequency Range	1GHz ~ 25GHz	Detector Function	Peak (PK) Average (AV)

Antenna Polarity & Test Distance : Horizontal at 3 m

No	Frequency (MHz)	Emission Level (dBuV/m)	Limit (dBuV/m)	Margin (dB)	Antenna Height (m)	Table Angle (Degree)	Raw Value (dBuV)	Correction Factor (dB/m)
1	*2462.00	110.2 PK			1.17 H	110	113.0	-2.8
2	*2462.00	98.5 AV			1.17 H	110	101.3	-2.8
3	2485.00	61.3 PK	74.0	-12.7	1.17 H	110	64.1	-2.8
4	2485.00	44.6 AV	54.0	-9.4	1.17 H	110	47.4	-2.8
5	4924.00	44.0 PK	74.0	-30.0	1.33 H	252	42.2	1.8
6	4924.00	33.0 AV	54.0	-21.0	1.33 H	252	31.2	1.8
7	7386.00	63.4 PK	74.0	-10.6	1.13 H	305	56.0	7.4
8	7386.00	47.4 AV	54.0	-6.6	1.13 H	305	40.0	7.4

Antenna Polarity & Test Distance : Vertical at 3 m

No	Frequency (MHz)	Emission Level (dBuV/m)	Limit (dBuV/m)	Margin (dB)	Antenna Height (m)	Table Angle (Degree)	Raw Value (dBuV)	Correction Factor (dB/m)
1	*2462.00	119.1 PK			1.48 V	256	121.9	-2.8
2	*2462.00	108.3 AV			1.48 V	256	111.1	-2.8
3	2484.30	72.2 PK	74.0	-1.8	1.48 V	256	75.0	-2.8
4	2484.30	48.4 AV	54.0	-5.6	1.48 V	256	51.2	-2.8
5	4924.00	46.8 PK	74.0	-27.2	1.25 V	82	45.0	1.8
6	4924.00	36.1 AV	54.0	-17.9	1.25 V	82	34.3	1.8
7	7386.00	66.2 PK	74.0	-7.8	1.22 V	50	58.8	7.4
8	7386.00	47.8 AV	54.0	-6.2	1.22 V	50	40.4	7.4

Remarks:

1. Emission Level(dBuV/m) = Raw Value(dBuV) + Correction Factor(dB/m)
2. Correction Factor(dB/m) = Antenna Factor(dB/m) + Cable Factor(dB) – Pre-Amplifier Factor(dB)
3. Margin value = Emission Level – Limit value
4. The other emission levels were very low against the limit.
5. " * ": Fundamental frequency.

RF Mode	TX 20MHz Preamble 802.11ax (RU106)	Channel	CH 12 : 2467 MHz
Frequency Range	1GHz ~ 25GHz	Detector Function	Peak (PK) Average (AV)

Antenna Polarity & Test Distance : Horizontal at 3 m

No	Frequency (MHz)	Emission Level (dBuV/m)	Limit (dBuV/m)	Margin (dB)	Antenna Height (m)	Table Angle (Degree)	Raw Value (dBuV)	Correction Factor (dB/m)
1	*2467.00	107.3 PK			1.20 H	108	110.1	-2.8
2	*2467.00	96.0 AV			1.20 H	108	98.8	-2.8
3	2483.50	64.2 PK	74.0	-9.8	1.20 H	108	67.0	-2.8
4	2483.50	44.3 AV	54.0	-9.7	1.20 H	108	47.1	-2.8
5	4934.00	43.9 PK	74.0	-30.1	1.33 H	253	42.1	1.8
6	4934.00	33.0 AV	54.0	-21.0	1.33 H	253	31.2	1.8
7	7401.00	63.1 PK	74.0	-10.9	1.10 H	317	55.6	7.5
8	7401.00	46.9 AV	54.0	-7.1	1.10 H	317	39.4	7.5

Antenna Polarity & Test Distance : Vertical at 3 m

No	Frequency (MHz)	Emission Level (dBuV/m)	Limit (dBuV/m)	Margin (dB)	Antenna Height (m)	Table Angle (Degree)	Raw Value (dBuV)	Correction Factor (dB/m)
1	*2467.00	117.7 PK			1.52 V	292	120.5	-2.8
2	*2467.00	106.5 AV			1.52 V	292	109.3	-2.8
3	2483.50	72.1 PK	74.0	-1.9	1.52 V	292	74.9	-2.8
4	2483.50	47.9 AV	54.0	-6.1	1.52 V	292	50.7	-2.8
5	4934.00	47.0 PK	74.0	-27.0	1.26 V	93	45.2	1.8
6	4934.00	36.0 AV	54.0	-18.0	1.26 V	93	34.2	1.8
7	7401.00	65.6 PK	74.0	-8.4	1.24 V	56	58.1	7.5
8	7401.00	47.5 AV	54.0	-6.5	1.24 V	56	40.0	7.5

Remarks:

1. Emission Level(dBuV/m) = Raw Value(dBuV) + Correction Factor(dB/m)
2. Correction Factor(dB/m) = Antenna Factor(dB/m) + Cable Factor(dB) – Pre-Amplifier Factor(dB)
3. Margin value = Emission Level – Limit value
4. The other emission levels were very low against the limit.
5. " * ": Fundamental frequency.

RF Mode	TX 20MHz Preamble 802.11ax (RU106)	Channel	CH 13 : 2472 MHz
Frequency Range	1GHz ~ 25GHz	Detector Function	Peak (PK) Average (AV)

Antenna Polarity & Test Distance : Horizontal at 3 m

No	Frequency (MHz)	Emission Level (dBuV/m)	Limit (dBuV/m)	Margin (dB)	Antenna Height (m)	Table Angle (Degree)	Raw Value (dBuV)	Correction Factor (dB/m)
1	*2472.00	102.2 PK			1.14 H	112	105.0	-2.8
2	*2472.00	91.4 AV			1.14 H	112	94.2	-2.8
3	2484.90	61.0 PK	74.0	-13.0	1.14 H	112	63.8	-2.8
4	2484.90	43.4 AV	54.0	-10.6	1.14 H	112	46.2	-2.8
5	4944.00	44.5 PK	74.0	-29.5	1.31 H	256	42.7	1.8
6	4944.00	33.4 AV	54.0	-20.6	1.31 H	256	31.6	1.8
7	7416.00	63.0 PK	74.0	-11.0	1.07 H	315	55.5	7.5
8	7416.00	46.7 AV	54.0	-7.3	1.07 H	315	39.2	7.5

Antenna Polarity & Test Distance : Vertical at 3 m

No	Frequency (MHz)	Emission Level (dBuV/m)	Limit (dBuV/m)	Margin (dB)	Antenna Height (m)	Table Angle (Degree)	Raw Value (dBuV)	Correction Factor (dB/m)
1	*2472.00	112.9 PK			1.46 V	281	115.7	-2.8
2	*2472.00	102.1 AV			1.46 V	281	104.9	-2.8
3	2483.50	72.4 PK	74.0	-1.6	1.46 V	281	75.2	-2.8
4	2483.50	48.4 AV	54.0	-5.6	1.46 V	281	51.2	-2.8
5	4944.00	46.9 PK	74.0	-27.1	1.21 V	91	45.1	1.8
6	4944.00	35.9 AV	54.0	-18.1	1.21 V	91	34.1	1.8
7	7416.00	66.8 PK	74.0	-7.2	1.30 V	47	59.3	7.5
8	7416.00	48.4 AV	54.0	-5.6	1.30 V	47	40.9	7.5

Remarks:

1. Emission Level(dBuV/m) = Raw Value(dBuV) + Correction Factor(dB/m)
2. Correction Factor(dB/m) = Antenna Factor(dB/m) + Cable Factor(dB) – Pre-Amplifier Factor(dB)
3. Margin value = Emission Level – Limit value
4. The other emission levels were very low against the limit.
5. " * ": Fundamental frequency.

Below 1GHz Data:

RF Mode	TX 802.11g	Channel	CH 6 : 2437 MHz
Frequency Range	9kHz ~ 1GHz	Detector Function	Quasi-Peak (QP)

Antenna Polarity & Test Distance : Horizontal at 3 m								
No	Frequency (MHz)	Emission Level (dBuV/m)	Limit (dBuV/m)	Margin (dB)	Antenna Height (m)	Table Angle (Degree)	Raw Value (dBuV)	Correction Factor (dB/m)
1	119.44	38.0 QP	43.5	-5.5	3.00 H	347	53.1	-15.1
2	166.58	35.3 QP	43.5	-8.2	2.00 H	148	48.4	-13.1
3	226.39	33.6 QP	46.0	-12.4	2.00 H	123	49.5	-15.9
4	298.80	34.9 QP	46.0	-11.1	1.50 H	84	47.2	-12.3
5	336.39	33.7 QP	46.0	-12.3	1.50 H	334	45.0	-11.3
6	574.63	26.8 QP	46.0	-19.2	1.50 H	121	33.0	-6.2

Remarks:

1. Emission Level(dBuV/m) = Raw Value(dBuV) + Correction Factor(dB/m)
2. Correction Factor(dB/m) = Antenna Factor(dB/m) + Cable Factor(dB) – Pre-Amplifier Factor(dB)
3. Margin value = Emission Level – Limit value
4. The other emission levels were very low against the limit of frequency range 30MHz~1000MHz.
5. The emission levels were very low against the limit of frequency range 9kHz~30MHz: the amplitude of spurious emissions attenuated more than 20 dB below the permissible value to be report.

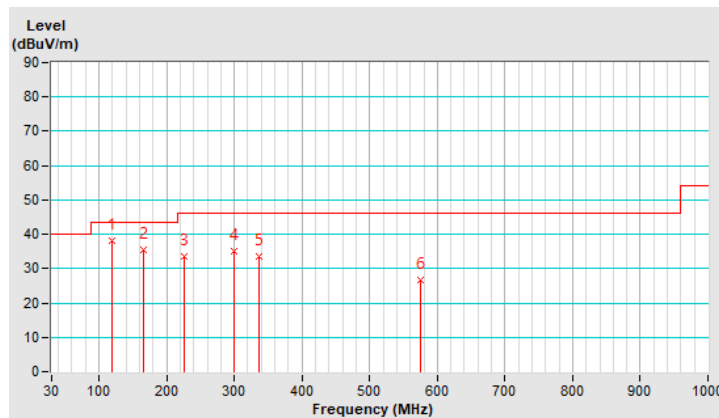

RF Mode	TX 802.11g	Channel	CH 6 : 2437 MHz
Frequency Range	9kHz ~ 1GHz	Detector Function	Quasi-Peak (QP)

Antenna Polarity & Test Distance : Vertical at 3 m								
No	Frequency (MHz)	Emission Level (dBuV/m)	Limit (dBuV/m)	Margin (dB)	Antenna Height (m)	Table Angle (Degree)	Raw Value (dBuV)	Correction Factor (dB/m)
1	125.45	29.1 QP	43.5	-14.4	1.00 V	37	43.6	-14.5
2	166.58	32.1 QP	43.5	-11.4	1.50 V	229	45.2	-13.1
3	223.43	31.3 QP	46.0	-14.7	1.00 V	135	47.3	-16.0
4	340.42	26.4 QP	46.0	-19.6	1.50 V	184	37.7	-11.3
5	498.58	24.6 QP	46.0	-21.4	1.50 V	43	32.3	-7.7
6	949.80	32.8 QP	46.0	-13.2	1.00 V	140	33.4	-0.6

Remarks:

1. Emission Level(dBuV/m) = Raw Value(dBuV) + Correction Factor(dB/m)
2. Correction Factor(dB/m) = Antenna Factor(dB/m) + Cable Factor(dB) – Pre-Amplifier Factor(dB)
3. Margin value = Emission Level – Limit value
4. The other emission levels were very low against the limit of frequency range 30MHz~1000MHz.
5. The emission levels were very low against the limit of frequency range 9kHz~30MHz: the amplitude of spurious emissions attenuated more than 20 dB below the permissible value to be report.

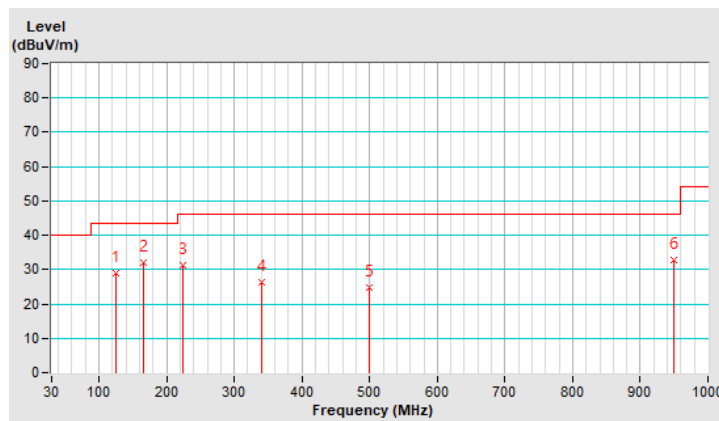

PIFA Antenna

Above 1GHz Data :

RF Mode	TX 802.11b	Channel	CH 1 : 2412 MHz
Frequency Range	1GHz ~ 25GHz	Detector Function	Peak (PK) Average (AV)

Antenna Polarity & Test Distance : Horizontal at 3 m

No	Frequency (MHz)	Emission Level (dBuV/m)	Limit (dBuV/m)	Margin (dB)	Antenna Height (m)	Table Angle (Degree)	Raw Value (dBuV)	Correction Factor (dB/m)
1	2386.14	57.7 PK	74.0	-16.3	1.26 H	278	60.4	-2.7
2	2386.14	47.7 AV	54.0	-6.3	1.26 H	278	50.4	-2.7
3	*2412.00	111.1 PK			1.26 H	278	113.8	-2.7
4	*2412.00	108.7 AV			1.26 H	278	111.4	-2.7
5	4824.00	45.3 PK	74.0	-28.7	2.07 H	118	43.5	1.8
6	4824.00	43.5 AV	54.0	-10.5	2.07 H	118	41.7	1.8

Antenna Polarity & Test Distance : Vertical at 3 m

No	Frequency (MHz)	Emission Level (dBuV/m)	Limit (dBuV/m)	Margin (dB)	Antenna Height (m)	Table Angle (Degree)	Raw Value (dBuV)	Correction Factor (dB/m)
1	2389.00	55.6 PK	74.0	-18.4	1.77 V	150	58.3	-2.7
2	2389.00	44.8 AV	54.0	-9.2	1.77 V	150	47.5	-2.7
3	*2412.00	106.1 PK			1.77 V	150	108.8	-2.7
4	*2412.00	103.9 AV			1.77 V	150	106.6	-2.7
5	4824.00	44.2 PK	74.0	-29.8	2.59 V	348	42.4	1.8
6	4824.00	40.3 AV	54.0	-13.7	2.59 V	348	38.5	1.8

Remarks:

1. Emission Level(dBuV/m) = Raw Value(dBuV) + Correction Factor(dB/m)
2. Correction Factor(dB/m) = Antenna Factor(dB/m) + Cable Factor(dB) – Pre-Amplifier Factor(dB)
3. Margin value = Emission Level – Limit value
4. The other emission levels were very low against the limit.
5. " * " : Fundamental frequency.

RF Mode	TX 802.11b	Channel	CH 6 : 2437 MHz
Frequency Range	1GHz ~ 25GHz	Detector Function	Peak (PK) Average (AV)

Antenna Polarity & Test Distance : Horizontal at 3 m

No	Frequency (MHz)	Emission Level (dBuV/m)	Limit (dBuV/m)	Margin (dB)	Antenna Height (m)	Table Angle (Degree)	Raw Value (dBuV)	Correction Factor (dB/m)
1	2390.00	58.4 PK	74.0	-15.6	1.29 H	262	61.1	-2.7
2	2390.00	45.7 AV	54.0	-8.3	1.29 H	262	48.4	-2.7
3	*2437.00	111.0 PK			1.29 H	262	113.7	-2.7
4	*2437.00	108.7 AV			1.29 H	262	111.4	-2.7
5	2483.50	59.1 PK	74.0	-14.9	1.29 H	262	61.9	-2.8
6	2483.50	44.5 AV	54.0	-9.5	1.29 H	262	47.3	-2.8
7	4874.00	47.0 PK	74.0	-27.0	1.57 H	290	45.3	1.7
8	4874.00	44.6 AV	54.0	-9.4	1.57 H	290	42.9	1.7
9	7311.00	54.3 PK	74.0	-19.7	2.57 H	97	47.1	7.2
10	7311.00	50.8 AV	54.0	-3.2	2.57 H	97	43.6	7.2

Antenna Polarity & Test Distance : Vertical at 3 m

No	Frequency (MHz)	Emission Level (dBuV/m)	Limit (dBuV/m)	Margin (dB)	Antenna Height (m)	Table Angle (Degree)	Raw Value (dBuV)	Correction Factor (dB/m)
1	2390.00	55.8 PK	74.0	-18.2	1.77 V	162	58.5	-2.7
2	2390.00	43.4 AV	54.0	-10.6	1.77 V	162	46.1	-2.7
3	*2437.00	106.1 PK			1.77 V	162	108.8	-2.7
4	*2437.00	103.7 AV			1.77 V	162	106.4	-2.7
5	2483.50	55.1 PK	74.0	-18.9	1.77 V	162	57.9	-2.8
6	2483.50	41.9 AV	54.0	-12.1	1.77 V	162	44.7	-2.8
7	4874.00	43.7 PK	74.0	-30.3	2.60 V	352	42.0	1.7
8	4874.00	39.9 AV	54.0	-14.1	2.60 V	352	38.2	1.7
9	7311.00	46.7 PK	74.0	-27.3	1.13 V	129	39.5	7.2
10	7311.00	38.7 AV	54.0	-15.3	1.13 V	129	31.5	7.2

Remarks:

1. Emission Level(dBuV/m) = Raw Value(dBuV) + Correction Factor(dB/m)
2. Correction Factor(dB/m) = Antenna Factor(dB/m) + Cable Factor(dB) – Pre-Amplifier Factor(dB)
3. Margin value = Emission Level – Limit value
4. The other emission levels were very low against the limit.
5. " * " : Fundamental frequency.

RF Mode	TX 802.11b	Channel	CH 11 : 2462 MHz
Frequency Range	1GHz ~ 25GHz	Detector Function	Peak (PK) Average (AV)

Antenna Polarity & Test Distance : Horizontal at 3 m

No	Frequency (MHz)	Emission Level (dBuV/m)	Limit (dBuV/m)	Margin (dB)	Antenna Height (m)	Table Angle (Degree)	Raw Value (dBuV)	Correction Factor (dB/m)
1	*2462.00	111.0 PK			1.16 H	283	113.8	-2.8
2	*2462.00	108.6 AV			1.16 H	283	111.4	-2.8
3	2487.91	58.2 PK	74.0	-15.8	1.16 H	283	61.0	-2.8
4	2487.91	49.9 AV	54.0	-4.1	1.16 H	283	52.7	-2.8
5	4924.00	47.5 PK	74.0	-26.5	1.51 H	295	45.7	1.8
6	4924.00	45.2 AV	54.0	-8.8	1.51 H	295	43.4	1.8
7	7386.00	54.1 PK	74.0	-19.9	2.63 H	96	46.7	7.4
8	7386.00	50.8 AV	54.0	-3.2	2.63 H	96	43.4	7.4

Antenna Polarity & Test Distance : Vertical at 3 m

No	Frequency (MHz)	Emission Level (dBuV/m)	Limit (dBuV/m)	Margin (dB)	Antenna Height (m)	Table Angle (Degree)	Raw Value (dBuV)	Correction Factor (dB/m)
1	*2462.00	106.2 PK			1.71 V	146	109.0	-2.8
2	*2462.00	103.9 AV			1.71 V	146	106.7	-2.8
3	2487.77	57.7 PK	74.0	-16.3	1.71 V	146	60.5	-2.8
4	2487.77	47.8 AV	54.0	-6.2	1.71 V	146	50.6	-2.8
5	4924.00	44.3 PK	74.0	-29.7	2.62 V	359	42.5	1.8
6	4924.00	40.0 AV	54.0	-14.0	2.62 V	359	38.2	1.8
7	7386.00	46.3 PK	74.0	-27.7	1.06 V	118	38.9	7.4
8	7386.00	38.2 AV	54.0	-15.8	1.06 V	118	30.8	7.4

Remarks:

1. Emission Level(dBuV/m) = Raw Value(dBuV) + Correction Factor(dB/m)
2. Correction Factor(dB/m) = Antenna Factor(dB/m) + Cable Factor(dB) – Pre-Amplifier Factor(dB)
3. Margin value = Emission Level – Limit value
4. The other emission levels were very low against the limit.
5. " * ": Fundamental frequency.

RF Mode	TX 802.11b	Channel	CH 12 : 2467 MHz
Frequency Range	1GHz ~ 25GHz	Detector Function	Peak (PK) Average (AV)

Antenna Polarity & Test Distance : Horizontal at 3 m

No	Frequency (MHz)	Emission Level (dBuV/m)	Limit (dBuV/m)	Margin (dB)	Antenna Height (m)	Table Angle (Degree)	Raw Value (dBuV)	Correction Factor (dB/m)
1	*2467.00	106.6 PK			1.14 H	345	109.4	-2.8
2	*2467.00	104.2 AV			1.14 H	345	107.0	-2.8
3	2483.50	59.6 PK	74.0	-14.4	1.14 H	345	62.4	-2.8
4	2483.50	49.3 AV	54.0	-4.7	1.14 H	345	52.1	-2.8
5	2485.00	58.1 PK	74.0	-15.9	1.14 H	345	60.9	-2.8
6	2485.00	52.2 AV	54.0	-1.8	1.14 H	345	55.0	-2.8
7	4934.00	46.8 PK	74.0	-27.2	1.57 H	290	45.0	1.8
8	4934.00	44.8 AV	54.0	-9.2	1.57 H	290	43.0	1.8
9	7401.00	51.4 PK	74.0	-22.6	2.67 H	90	43.9	7.5
10	7401.00	47.8 AV	54.0	-6.2	2.67 H	90	40.3	7.5

Antenna Polarity & Test Distance : Vertical at 3 m

No	Frequency (MHz)	Emission Level (dBuV/m)	Limit (dBuV/m)	Margin (dB)	Antenna Height (m)	Table Angle (Degree)	Raw Value (dBuV)	Correction Factor (dB/m)
1	*2467.00	101.6 PK			1.60 V	138	104.4	-2.8
2	*2467.00	99.2 AV			1.60 V	138	102.0	-2.8
3	2483.50	56.7 PK	74.0	-17.3	1.60 V	138	59.5	-2.8
4	2483.50	46.5 AV	54.0	-7.5	1.60 V	138	49.3	-2.8
5	2485.10	56.4 PK	74.0	-17.6	1.60 V	138	59.2	-2.8
6	2485.10	47.8 AV	54.0	-6.2	1.60 V	138	50.6	-2.8
7	4934.00	44.3 PK	74.0	-29.7	2.66 V	347	42.5	1.8
8	4934.00	40.3 AV	54.0	-13.7	2.66 V	347	38.5	1.8
9	7401.00	46.6 PK	74.0	-27.4	1.08 V	133	39.1	7.5
10	7401.00	38.7 AV	54.0	-15.3	1.08 V	133	31.2	7.5

Remarks:

1. Emission Level(dBuV/m) = Raw Value(dBuV) + Correction Factor(dB/m)
2. Correction Factor(dB/m) = Antenna Factor(dB/m) + Cable Factor(dB) – Pre-Amplifier Factor(dB)
3. Margin value = Emission Level – Limit value
4. The other emission levels were very low against the limit.
5. " * " : Fundamental frequency.

RF Mode	TX 802.11b	Channel	CH 13 : 2472 MHz
Frequency Range	1GHz ~ 25GHz	Detector Function	Peak (PK) Average (AV)

Antenna Polarity & Test Distance : Horizontal at 3 m

No	Frequency (MHz)	Emission Level (dBuV/m)	Limit (dBuV/m)	Margin (dB)	Antenna Height (m)	Table Angle (Degree)	Raw Value (dBuV)	Correction Factor (dB/m)
1	*2472.00	102.6 PK			1.18 H	279	105.4	-2.8
2	*2472.00	100.4 AV			1.18 H	279	103.2	-2.8
3	2484.62	60.2 PK	74.0	-13.8	1.18 H	279	63.0	-2.8
4	2484.62	51.5 AV	54.0	-2.5	1.18 H	279	54.3	-2.8
5	4944.00	42.6 PK	74.0	-31.4	1.46 H	309	40.8	1.8
6	4944.00	40.3 AV	54.0	-13.7	1.46 H	309	38.5	1.8
7	7416.00	49.4 PK	74.0	-24.6	2.64 H	85	41.9	7.5
8	7416.00	46.2 AV	54.0	-7.8	2.64 H	85	38.7	7.5

Antenna Polarity & Test Distance : Vertical at 3 m

No	Frequency (MHz)	Emission Level (dBuV/m)	Limit (dBuV/m)	Margin (dB)	Antenna Height (m)	Table Angle (Degree)	Raw Value (dBuV)	Correction Factor (dB/m)
1	*2472.00	97.7 PK			1.76 V	143	100.5	-2.8
2	*2472.00	95.4 AV			1.76 V	143	98.2	-2.8
3	2484.61	56.9 PK	74.0	-17.1	1.76 V	143	59.7	-2.8
4	2484.61	48.0 AV	54.0	-6.0	1.76 V	143	50.8	-2.8
5	4944.00	44.7 PK	74.0	-29.3	2.70 V	336	42.9	1.8
6	4944.00	40.6 AV	54.0	-13.4	2.70 V	336	38.8	1.8
7	7416.00	46.2 PK	74.0	-27.8	1.04 V	145	38.7	7.5
8	7416.00	38.3 AV	54.0	-15.7	1.04 V	145	30.8	7.5

Remarks:

1. Emission Level(dBuV/m) = Raw Value(dBuV) + Correction Factor(dB/m)
2. Correction Factor(dB/m) = Antenna Factor(dB/m) + Cable Factor(dB) – Pre-Amplifier Factor(dB)
3. Margin value = Emission Level – Limit value
4. The other emission levels were very low against the limit.
5. " * ": Fundamental frequency.

RF Mode	TX 802.11g	Channel	CH 1 : 2412 MHz
Frequency Range	1GHz ~ 25GHz	Detector Function	Peak (PK) Average (AV)

Antenna Polarity & Test Distance : Horizontal at 3 m

No	Frequency (MHz)	Emission Level (dBuV/m)	Limit (dBuV/m)	Margin (dB)	Antenna Height (m)	Table Angle (Degree)	Raw Value (dBuV)	Correction Factor (dB/m)
1	2390.00	57.8 PK	74.0	-16.2	1.25 H	279	60.5	-2.7
2	2390.00	45.7 AV	54.0	-8.3	1.25 H	279	48.4	-2.7
3	*2412.00	110.9 PK			1.25 H	279	113.6	-2.7
4	*2412.00	102.0 AV			1.25 H	279	104.7	-2.7
5	4824.00	47.2 PK	74.0	-26.8	1.56 H	280	45.4	1.8
6	4824.00	45.3 AV	54.0	-8.7	1.56 H	280	43.5	1.8

Antenna Polarity & Test Distance : Vertical at 3 m

No	Frequency (MHz)	Emission Level (dBuV/m)	Limit (dBuV/m)	Margin (dB)	Antenna Height (m)	Table Angle (Degree)	Raw Value (dBuV)	Correction Factor (dB/m)
1	2390.00	57.2 PK	74.0	-16.8	1.70 V	140	59.9	-2.7
2	2390.00	44.3 AV	54.0	-9.7	1.70 V	140	47.0	-2.7
3	*2412.00	107.7 PK			1.70 V	140	110.4	-2.7
4	*2412.00	97.8 AV			1.70 V	140	100.5	-2.7
5	4824.00	44.4 PK	74.0	-29.6	2.63 V	342	42.6	1.8
6	4824.00	40.2 AV	54.0	-13.8	2.63 V	342	38.4	1.8

Remarks:

1. Emission Level(dBuV/m) = Raw Value(dBuV) + Correction Factor(dB/m)
2. Correction Factor(dB/m) = Antenna Factor(dB/m) + Cable Factor(dB) – Pre-Amplifier Factor(dB)
3. Margin value = Emission Level – Limit value
4. The other emission levels were very low against the limit.
5. " * ": Fundamental frequency.

RF Mode	TX 802.11g	Channel	CH 6 : 2437 MHz
Frequency Range	1GHz ~ 25GHz	Detector Function	Peak (PK) Average (AV)

Antenna Polarity & Test Distance : Horizontal at 3 m

No	Frequency (MHz)	Emission Level (dBuV/m)	Limit (dBuV/m)	Margin (dB)	Antenna Height (m)	Table Angle (Degree)	Raw Value (dBuV)	Correction Factor (dB/m)
1	2390.00	58.0 PK	74.0	-16.0	1.26 H	286	60.7	-2.7
2	2390.00	45.5 AV	54.0	-8.5	1.26 H	286	48.2	-2.7
3	*2437.00	115.9 PK			1.26 H	286	118.6	-2.7
4	*2437.00	107.2 AV			1.26 H	286	109.9	-2.7
5	2483.50	60.2 PK	74.0	-13.8	1.26 H	286	63.0	-2.8
6	2483.50	45.3 AV	54.0	-8.7	1.26 H	286	48.1	-2.8
7	4874.00	46.3 PK	74.0	-27.7	1.58 H	295	44.6	1.7
8	4874.00	44.1 AV	54.0	-9.9	1.58 H	295	42.4	1.7
9	7311.00	64.0 PK	74.0	-10.0	2.56 H	97	56.8	7.2
10	7311.00	50.9 AV	54.0	-3.1	2.56 H	97	43.7	7.2

Antenna Polarity & Test Distance : Vertical at 3 m

No	Frequency (MHz)	Emission Level (dBuV/m)	Limit (dBuV/m)	Margin (dB)	Antenna Height (m)	Table Angle (Degree)	Raw Value (dBuV)	Correction Factor (dB/m)
1	2390.00	56.1 PK	74.0	-17.9	1.68 V	137	58.8	-2.7
2	2390.00	43.4 AV	54.0	-10.6	1.68 V	137	46.1	-2.7
3	*2437.00	112.3 PK			1.68 V	137	115.0	-2.7
4	*2437.00	102.4 AV			1.68 V	137	105.1	-2.7
5	2483.50	55.5 PK	74.0	-18.5	1.68 V	137	58.3	-2.8
6	2483.50	42.1 AV	54.0	-11.9	1.68 V	137	44.9	-2.8
7	4874.00	44.9 PK	74.0	-29.1	2.60 V	333	43.2	1.7
8	4874.00	40.7 AV	54.0	-13.3	2.60 V	333	39.0	1.7
9	7311.00	46.7 PK	74.0	-27.3	1.07 V	130	39.5	7.2
10	7311.00	38.6 AV	54.0	-15.4	1.07 V	130	31.4	7.2

Remarks:

1. Emission Level(dBuV/m) = Raw Value(dBuV) + Correction Factor(dB/m)
2. Correction Factor(dB/m) = Antenna Factor(dB/m) + Cable Factor(dB) – Pre-Amplifier Factor(dB)
3. Margin value = Emission Level – Limit value
4. The other emission levels were very low against the limit.
5. " * " : Fundamental frequency.

RF Mode	TX 802.11g	Channel	CH 11 : 2462 MHz
Frequency Range	1GHz ~ 25GHz	Detector Function	Peak (PK) Average (AV)

Antenna Polarity & Test Distance : Horizontal at 3 m

No	Frequency (MHz)	Emission Level (dBuV/m)	Limit (dBuV/m)	Margin (dB)	Antenna Height (m)	Table Angle (Degree)	Raw Value (dBuV)	Correction Factor (dB/m)
1	*2462.00	110.6 PK			1.17 H	273	113.4	-2.8
2	*2462.00	101.7 AV			1.17 H	273	104.5	-2.8
3	2483.50	60.8 PK	74.0	-13.2	1.17 H	273	63.6	-2.8
4	2483.50	47.1 AV	54.0	-6.9	1.17 H	273	49.9	-2.8
5	4924.00	46.5 PK	74.0	-27.5	1.61 H	285	44.7	1.8
6	4924.00	44.7 AV	54.0	-9.3	1.61 H	285	42.9	1.8
7	7386.00	51.2 PK	74.0	-22.8	2.68 H	98	43.8	7.4
8	7386.00	47.4 AV	54.0	-6.6	2.68 H	98	40.0	7.4

Antenna Polarity & Test Distance : Vertical at 3 m

No	Frequency (MHz)	Emission Level (dBuV/m)	Limit (dBuV/m)	Margin (dB)	Antenna Height (m)	Table Angle (Degree)	Raw Value (dBuV)	Correction Factor (dB/m)
1	*2462.00	107.7 PK			1.68 V	135	110.5	-2.8
2	*2462.00	98.1 AV			1.68 V	135	100.9	-2.8
3	2483.50	58.1 PK	74.0	-15.9	1.68 V	135	60.9	-2.8
4	2483.50	45.7 AV	54.0	-8.3	1.68 V	135	48.5	-2.8
5	4924.00	43.8 PK	74.0	-30.2	2.56 V	350	42.0	1.8
6	4924.00	39.9 AV	54.0	-14.1	2.56 V	350	38.1	1.8
7	7386.00	46.5 PK	74.0	-27.5	1.18 V	121	39.1	7.4
8	7386.00	38.3 AV	54.0	-15.7	1.18 V	121	30.9	7.4

Remarks:

1. Emission Level(dBuV/m) = Raw Value(dBuV) + Correction Factor(dB/m)
2. Correction Factor(dB/m) = Antenna Factor(dB/m) + Cable Factor(dB) – Pre-Amplifier Factor(dB)
3. Margin value = Emission Level – Limit value
4. The other emission levels were very low against the limit.
5. " * ": Fundamental frequency.

RF Mode	TX 802.11g	Channel	CH 12 : 2467 MHz
Frequency Range	1GHz ~ 25GHz	Detector Function	Peak (PK) Average (AV)

Antenna Polarity & Test Distance : Horizontal at 3 m

No	Frequency (MHz)	Emission Level (dBuV/m)	Limit (dBuV/m)	Margin (dB)	Antenna Height (m)	Table Angle (Degree)	Raw Value (dBuV)	Correction Factor (dB/m)
1	*2467.00	106.5 PK			1.15 H	277	109.3	-2.8
2	*2467.00	98.0 AV			1.15 H	277	100.8	-2.8
3	2483.50	59.8 PK	74.0	-14.2	1.15 H	277	62.6	-2.8
4	2483.50	46.3 AV	54.0	-7.7	1.15 H	277	49.1	-2.8
5	4934.00	46.6 PK	74.0	-27.4	1.54 H	288	44.8	1.8
6	4934.00	44.8 AV	54.0	-9.2	1.54 H	288	43.0	1.8
7	7401.00	50.9 PK	74.0	-23.1	2.69 H	100	43.4	7.5
8	7401.00	47.3 AV	54.0	-6.7	2.69 H	100	39.8	7.5

Antenna Polarity & Test Distance : Vertical at 3 m

No	Frequency (MHz)	Emission Level (dBuV/m)	Limit (dBuV/m)	Margin (dB)	Antenna Height (m)	Table Angle (Degree)	Raw Value (dBuV)	Correction Factor (dB/m)
1	*2467.00	103.7 PK			1.77 V	139	106.5	-2.8
2	*2467.00	94.1 AV			1.77 V	139	96.9	-2.8
3	2483.50	56.4 PK	74.0	-17.6	1.77 V	139	59.2	-2.8
4	2483.50	44.9 AV	54.0	-9.1	1.77 V	139	47.7	-2.8
5	4934.00	43.9 PK	74.0	-30.1	2.65 V	332	42.1	1.8
6	4934.00	40.2 AV	54.0	-13.8	2.65 V	332	38.4	1.8
7	7401.00	46.8 PK	74.0	-27.2	1.03 V	126	39.3	7.5
8	7401.00	38.8 AV	54.0	-15.2	1.03 V	126	31.3	7.5

Remarks:

1. Emission Level(dBuV/m) = Raw Value(dBuV) + Correction Factor(dB/m)
2. Correction Factor(dB/m) = Antenna Factor(dB/m) + Cable Factor(dB) – Pre-Amplifier Factor(dB)
3. Margin value = Emission Level – Limit value
4. The other emission levels were very low against the limit.
5. " * ": Fundamental frequency.

RF Mode	TX 802.11g	Channel	CH 13 : 2472 MHz
Frequency Range	1GHz ~ 25GHz	Detector Function	Peak (PK) Average (AV)

Antenna Polarity & Test Distance : Horizontal at 3 m

No	Frequency (MHz)	Emission Level (dBuV/m)	Limit (dBuV/m)	Margin (dB)	Antenna Height (m)	Table Angle (Degree)	Raw Value (dBuV)	Correction Factor (dB/m)
1	*2472.00	106.6 PK			1.15 H	277	109.4	-2.8
2	*2472.00	96.7 AV			1.15 H	277	99.5	-2.8
3	2483.50	59.4 PK	74.0	-14.6	1.15 H	277	62.2	-2.8
4	2483.50	47.0 AV	54.0	-7.0	1.15 H	277	49.8	-2.8
5	4944.00	46.3 PK	74.0	-27.7	1.54 H	287	44.5	1.8
6	4944.00	44.4 AV	54.0	-9.6	1.54 H	287	42.6	1.8
7	7416.00	51.1 PK	74.0	-22.9	2.64 H	96	43.6	7.5
8	7416.00	47.3 AV	54.0	-6.7	2.64 H	96	39.8	7.5

Antenna Polarity & Test Distance : Vertical at 3 m

No	Frequency (MHz)	Emission Level (dBuV/m)	Limit (dBuV/m)	Margin (dB)	Antenna Height (m)	Table Angle (Degree)	Raw Value (dBuV)	Correction Factor (dB/m)
1	*2472.00	102.9 PK			1.81 V	149	105.7	-2.8
2	*2472.00	93.0 AV			1.81 V	149	95.8	-2.8
3	2483.50	57.1 PK	74.0	-16.9	1.81 V	149	59.9	-2.8
4	2483.50	45.5 AV	54.0	-8.5	1.81 V	149	48.3	-2.8
5	4944.00	43.4 PK	74.0	-30.6	2.55 V	349	41.6	1.8
6	4944.00	39.7 AV	54.0	-14.3	2.55 V	349	37.9	1.8
7	7416.00	46.4 PK	74.0	-27.6	1.22 V	129	38.9	7.5
8	7416.00	38.0 AV	54.0	-16.0	1.22 V	129	30.5	7.5

Remarks:

1. Emission Level(dBuV/m) = Raw Value(dBuV) + Correction Factor(dB/m)
2. Correction Factor(dB/m) = Antenna Factor(dB/m) + Cable Factor(dB) – Pre-Amplifier Factor(dB)
3. Margin value = Emission Level – Limit value
4. The other emission levels were very low against the limit.
5. " * ": Fundamental frequency.

RF Mode	TX 802.11ax (HE20)	Channel	CH 1 : 2412 MHz
Frequency Range	1GHz ~ 25GHz	Detector Function	Peak (PK) Average (AV)

Antenna Polarity & Test Distance : Horizontal at 3 m

No	Frequency (MHz)	Emission Level (dBuV/m)	Limit (dBuV/m)	Margin (dB)	Antenna Height (m)	Table Angle (Degree)	Raw Value (dBuV)	Correction Factor (dB/m)
1	2390.00	58.2 PK	74.0	-15.8	1.23 H	279	60.9	-2.7
2	2390.00	45.6 AV	54.0	-8.4	1.23 H	279	48.3	-2.7
3	*2412.00	110.8 PK			1.23 H	279	113.5	-2.7
4	*2412.00	100.3 AV			1.23 H	279	103.0	-2.7
5	4824.00	47.3 PK	74.0	-26.7	1.56 H	280	45.5	1.8
6	4824.00	45.0 AV	54.0	-9.0	1.56 H	280	43.2	1.8

Antenna Polarity & Test Distance : Vertical at 3 m

No	Frequency (MHz)	Emission Level (dBuV/m)	Limit (dBuV/m)	Margin (dB)	Antenna Height (m)	Table Angle (Degree)	Raw Value (dBuV)	Correction Factor (dB/m)
1	2390.00	56.1 PK	74.0	-17.9	1.76 V	141	58.8	-2.7
2	2390.00	44.1 AV	54.0	-9.9	1.76 V	141	46.8	-2.7
3	*2412.00	107.4 PK			1.76 V	141	110.1	-2.7
4	*2412.00	96.4 AV			1.76 V	141	99.1	-2.7
5	4824.00	43.9 PK	74.0	-30.1	2.65 V	357	42.1	1.8
6	4824.00	39.9 AV	54.0	-14.1	2.65 V	357	38.1	1.8

Remarks:

1. Emission Level(dBuV/m) = Raw Value(dBuV) + Correction Factor(dB/m)
2. Correction Factor(dB/m) = Antenna Factor(dB/m) + Cable Factor(dB) – Pre-Amplifier Factor(dB)
3. Margin value = Emission Level – Limit value
4. The other emission levels were very low against the limit.
5. " * " : Fundamental frequency.

RF Mode	TX 802.11ax (HE20)	Channel	CH 6 : 2437 MHz
Frequency Range	1GHz ~ 25GHz	Detector Function	Peak (PK) Average (AV)

Antenna Polarity & Test Distance : Horizontal at 3 m

No	Frequency (MHz)	Emission Level (dBuV/m)	Limit (dBuV/m)	Margin (dB)	Antenna Height (m)	Table Angle (Degree)	Raw Value (dBuV)	Correction Factor (dB/m)
1	2390.00	58.1 PK	74.0	-15.9	1.18 H	281	60.8	-2.7
2	2390.00	45.6 AV	54.0	-8.4	1.18 H	281	48.3	-2.7
3	*2437.00	117.7 PK			1.18 H	281	120.4	-2.7
4	*2437.00	106.8 AV			1.18 H	281	109.5	-2.7
5	2483.50	59.9 PK	74.0	-14.1	1.18 H	281	62.7	-2.8
6	2483.50	45.0 AV	54.0	-9.0	1.18 H	281	47.8	-2.8
7	4874.00	46.9 PK	74.0	-27.1	1.60 H	289	45.2	1.7
8	4874.00	44.9 AV	54.0	-9.1	1.60 H	289	43.2	1.7
9	7311.00	63.4 PK	74.0	-10.6	2.58 H	99	56.2	7.2
10	7311.00	50.5 AV	54.0	-3.5	2.58 H	99	43.3	7.2

Antenna Polarity & Test Distance : Vertical at 3 m

No	Frequency (MHz)	Emission Level (dBuV/m)	Limit (dBuV/m)	Margin (dB)	Antenna Height (m)	Table Angle (Degree)	Raw Value (dBuV)	Correction Factor (dB/m)
1	2390.00	55.4 PK	74.0	-18.6	1.81 V	130	58.1	-2.7
2	2390.00	43.0 AV	54.0	-11.0	1.81 V	130	45.7	-2.7
3	*2437.00	113.3 PK			1.81 V	130	116.0	-2.7
4	*2437.00	102.2 AV			1.81 V	130	104.9	-2.7
5	2483.50	55.7 PK	74.0	-18.3	1.81 V	130	58.5	-2.8
6	2483.50	42.4 AV	54.0	-11.6	1.81 V	130	45.2	-2.8
7	4874.00	42.7 PK	74.0	-31.3	2.58 V	344	41.0	1.7
8	4874.00	39.3 AV	54.0	-14.7	2.58 V	344	37.6	1.7
9	7311.00	46.5 PK	74.0	-27.5	1.18 V	143	39.3	7.2
10	7311.00	38.3 AV	54.0	-15.7	1.18 V	143	31.1	7.2

Remarks:

1. Emission Level(dBuV/m) = Raw Value(dBuV) + Correction Factor(dB/m)
2. Correction Factor(dB/m) = Antenna Factor(dB/m) + Cable Factor(dB) – Pre-Amplifier Factor(dB)
3. Margin value = Emission Level – Limit value
4. The other emission levels were very low against the limit.
5. " * ": Fundamental frequency.

RF Mode	TX 802.11ax (HE20)	Channel	CH 11 : 2462 MHz
Frequency Range	1GHz ~ 25GHz	Detector Function	Peak (PK) Average (AV)

Antenna Polarity & Test Distance : Horizontal at 3 m

No	Frequency (MHz)	Emission Level (dBuV/m)	Limit (dBuV/m)	Margin (dB)	Antenna Height (m)	Table Angle (Degree)	Raw Value (dBuV)	Correction Factor (dB/m)
1	*2462.00	111.3 PK			1.20 H	275	114.1	-2.8
2	*2462.00	100.7 AV			1.20 H	275	103.5	-2.8
3	2483.50	60.5 PK	74.0	-13.5	1.20 H	275	63.3	-2.8
4	2483.50	47.0 AV	54.0	-7.0	1.20 H	275	49.8	-2.8
5	4924.00	47.3 PK	74.0	-26.7	1.59 H	279	45.5	1.8
6	4924.00	45.1 AV	54.0	-8.9	1.59 H	279	43.3	1.8
7	7386.00	51.4 PK	74.0	-22.6	2.61 H	91	44.0	7.4
8	7386.00	47.8 AV	54.0	-6.2	2.61 H	91	40.4	7.4

Antenna Polarity & Test Distance : Vertical at 3 m

No	Frequency (MHz)	Emission Level (dBuV/m)	Limit (dBuV/m)	Margin (dB)	Antenna Height (m)	Table Angle (Degree)	Raw Value (dBuV)	Correction Factor (dB/m)
1	*2462.00	107.8 PK			1.70 V	156	110.6	-2.8
2	*2462.00	96.6 AV			1.70 V	156	99.4	-2.8
3	2483.50	60.8 PK	74.0	-13.2	1.70 V	156	63.6	-2.8
4	2483.50	46.0 AV	54.0	-8.0	1.70 V	156	48.8	-2.8
5	4924.00	43.3 PK	74.0	-30.7	2.52 V	349	41.5	1.8
6	4924.00	39.7 AV	54.0	-14.3	2.52 V	349	37.9	1.8
7	7386.00	46.4 PK	74.0	-27.6	1.20 V	123	39.0	7.4
8	7386.00	37.9 AV	54.0	-16.1	1.20 V	123	30.5	7.4

Remarks:

1. Emission Level(dBuV/m) = Raw Value(dBuV) + Correction Factor(dB/m)
2. Correction Factor(dB/m) = Antenna Factor(dB/m) + Cable Factor(dB) – Pre-Amplifier Factor(dB)
3. Margin value = Emission Level – Limit value
4. The other emission levels were very low against the limit.
5. " * ": Fundamental frequency.

RF Mode	TX 802.11ax (HE20)	Channel	CH 12 : 2467 MHz
Frequency Range	1GHz ~ 25GHz	Detector Function	Peak (PK) Average (AV)

Antenna Polarity & Test Distance : Horizontal at 3 m

No	Frequency (MHz)	Emission Level (dBuV/m)	Limit (dBuV/m)	Margin (dB)	Antenna Height (m)	Table Angle (Degree)	Raw Value (dBuV)	Correction Factor (dB/m)
1	*2467.00	107.8 PK			1.17 H	283	110.6	-2.8
2	*2467.00	97.2 AV			1.17 H	283	100.0	-2.8
3	2483.50	59.8 PK	74.0	-14.2	1.17 H	283	62.6	-2.8
4	2483.50	46.1 AV	54.0	-7.9	1.17 H	283	48.9	-2.8
5	4934.00	46.0 PK	74.0	-28.0	1.51 H	295	44.2	1.8
6	4934.00	44.3 AV	54.0	-9.7	1.51 H	295	42.5	1.8
7	7401.00	51.8 PK	74.0	-22.2	2.69 H	95	44.3	7.5
8	7401.00	48.1 AV	54.0	-5.9	2.69 H	95	40.6	7.5

Antenna Polarity & Test Distance : Vertical at 3 m

No	Frequency (MHz)	Emission Level (dBuV/m)	Limit (dBuV/m)	Margin (dB)	Antenna Height (m)	Table Angle (Degree)	Raw Value (dBuV)	Correction Factor (dB/m)
1	*2467.00	104.4 PK			1.96 V	143	107.2	-2.8
2	*2467.00	93.3 AV			1.96 V	143	96.1	-2.8
3	2483.50	56.8 PK	74.0	-17.2	1.96 V	143	59.6	-2.8
4	2483.50	45.0 AV	54.0	-9.0	1.96 V	143	47.8	-2.8
5	4934.00	42.9 PK	74.0	-31.1	2.60 V	347	41.1	1.8
6	4934.00	39.2 AV	54.0	-14.8	2.60 V	347	37.4	1.8
7	7401.00	46.4 PK	74.0	-27.6	1.16 V	145	38.9	7.5
8	7401.00	38.1 AV	54.0	-15.9	1.16 V	145	30.6	7.5

Remarks:

1. Emission Level(dBuV/m) = Raw Value(dBuV) + Correction Factor(dB/m)
2. Correction Factor(dB/m) = Antenna Factor(dB/m) + Cable Factor(dB) – Pre-Amplifier Factor(dB)
3. Margin value = Emission Level – Limit value
4. The other emission levels were very low against the limit.
5. " * ": Fundamental frequency.

RF Mode	TX 802.11ax (HE20)	Channel	CH 13 : 2472 MHz
Frequency Range	1GHz ~ 25GHz	Detector Function	Peak (PK) Average (AV)

Antenna Polarity & Test Distance : Horizontal at 3 m

No	Frequency (MHz)	Emission Level (dBuV/m)	Limit (dBuV/m)	Margin (dB)	Antenna Height (m)	Table Angle (Degree)	Raw Value (dBuV)	Correction Factor (dB/m)
1	*2472.00	107.1 PK			1.13 H	278	109.9	-2.8
2	*2472.00	96.3 AV			1.13 H	278	99.1	-2.8
3	2483.50	65.4 PK	74.0	-8.6	1.13 H	278	68.2	-2.8
4	2483.50	46.9 AV	54.0	-7.1	1.13 H	278	49.7	-2.8
5	4944.00	46.5 PK	74.0	-27.5	1.59 H	278	44.7	1.8
6	4944.00	44.5 AV	54.0	-9.5	1.59 H	278	42.7	1.8
7	7416.00	51.5 PK	74.0	-22.5	2.68 H	98	44.0	7.5
8	7416.00	48.2 AV	54.0	-5.8	2.68 H	98	40.7	7.5

Antenna Polarity & Test Distance : Vertical at 3 m

No	Frequency (MHz)	Emission Level (dBuV/m)	Limit (dBuV/m)	Margin (dB)	Antenna Height (m)	Table Angle (Degree)	Raw Value (dBuV)	Correction Factor (dB/m)
1	*2472.00	103.6 PK			1.89 V	155	106.4	-2.8
2	*2472.00	92.6 AV			1.89 V	155	95.4	-2.8
3	2483.50	58.3 PK	74.0	-15.7	1.89 V	155	61.1	-2.8
4	2483.50	45.1 AV	54.0	-8.9	1.89 V	155	47.9	-2.8
5	4944.00	43.1 PK	74.0	-30.9	2.58 V	354	41.3	1.8
6	4944.00	39.6 AV	54.0	-14.4	2.58 V	354	37.8	1.8
7	7416.00	46.5 PK	74.0	-27.5	1.23 V	119	39.0	7.5
8	7416.00	38.2 AV	54.0	-15.8	1.23 V	119	30.7	7.5

Remarks:

1. Emission Level(dBuV/m) = Raw Value(dBuV) + Correction Factor(dB/m)
2. Correction Factor(dB/m) = Antenna Factor(dB/m) + Cable Factor(dB) – Pre-Amplifier Factor(dB)
3. Margin value = Emission Level – Limit value
4. The other emission levels were very low against the limit.
5. " * ": Fundamental frequency.

RF Mode	TX 802.11ax (HE40)	Channel	CH 3 : 2422 MHz
Frequency Range	1GHz ~ 25GHz	Detector Function	Peak (PK) Average (AV)

Antenna Polarity & Test Distance : Horizontal at 3 m

No	Frequency (MHz)	Emission Level (dBuV/m)	Limit (dBuV/m)	Margin (dB)	Antenna Height (m)	Table Angle (Degree)	Raw Value (dBuV)	Correction Factor (dB/m)
1	2390.00	57.6 PK	74.0	-16.4	1.00 H	277	60.3	-2.7
2	2390.00	45.6 AV	54.0	-8.4	1.00 H	277	48.3	-2.7
3	*2422.00	107.4 PK			1.00 H	277	110.1	-2.7
4	*2422.00	95.3 AV			1.00 H	277	98.0	-2.7
5	4844.00	46.8 PK	74.0	-27.2	1.59 H	294	45.0	1.8
6	4844.00	44.5 AV	54.0	-9.5	1.59 H	294	42.7	1.8
7	7266.00	51.1 PK	74.0	-22.9	2.69 H	89	43.8	7.3
8	7266.00	47.3 AV	54.0	-6.7	2.69 H	89	40.0	7.3

Antenna Polarity & Test Distance : Vertical at 3 m

No	Frequency (MHz)	Emission Level (dBuV/m)	Limit (dBuV/m)	Margin (dB)	Antenna Height (m)	Table Angle (Degree)	Raw Value (dBuV)	Correction Factor (dB/m)
1	2390.00	55.7 PK	74.0	-18.3	1.91 V	161	58.4	-2.7
2	2390.00	43.7 AV	54.0	-10.3	1.91 V	161	46.4	-2.7
3	*2422.00	103.3 PK			1.91 V	161	106.0	-2.7
4	*2422.00	91.3 AV			1.91 V	161	94.0	-2.7
5	4844.00	43.3 PK	74.0	-30.7	2.52 V	335	41.5	1.8
6	4844.00	39.7 AV	54.0	-14.3	2.52 V	335	37.9	1.8
7	7266.00	46.3 PK	74.0	-27.7	1.27 V	123	39.0	7.3
8	7266.00	37.8 AV	54.0	-16.2	1.27 V	123	30.5	7.3

Remarks:

1. Emission Level(dBuV/m) = Raw Value(dBuV) + Correction Factor(dB/m)
2. Correction Factor(dB/m) = Antenna Factor(dB/m) + Cable Factor(dB) – Pre-Amplifier Factor(dB)
3. Margin value = Emission Level – Limit value
4. The other emission levels were very low against the limit.
5. " * ": Fundamental frequency.

RF Mode	TX 802.11ax (HE40)	Channel	CH 6 : 2437 MHz
Frequency Range	1GHz ~ 25GHz	Detector Function	Peak (PK) Average (AV)

Antenna Polarity & Test Distance : Horizontal at 3 m

No	Frequency (MHz)	Emission Level (dBuV/m)	Limit (dBuV/m)	Margin (dB)	Antenna Height (m)	Table Angle (Degree)	Raw Value (dBuV)	Correction Factor (dB/m)
1	2390.00	62.0 PK	74.0	-12.0	1.06 H	290	64.7	-2.7
2	2390.00	47.5 AV	54.0	-6.5	1.06 H	290	50.2	-2.7
3	*2437.00	110.3 PK			1.06 H	290	113.0	-2.7
4	*2437.00	98.4 AV			1.06 H	290	101.1	-2.7
5	2483.50	66.7 PK	74.0	-7.3	1.06 H	290	69.5	-2.8
6	2483.50	50.1 AV	54.0	-3.9	1.06 H	290	52.9	-2.8
7	4874.00	46.2 PK	74.0	-27.8	1.52 H	285	44.5	1.7
8	4874.00	44.3 AV	54.0	-9.7	1.52 H	285	42.6	1.7
9	7311.00	51.9 PK	74.0	-22.1	2.70 H	95	44.7	7.2
10	7311.00	48.2 AV	54.0	-5.8	2.70 H	95	41.0	7.2

Antenna Polarity & Test Distance : Vertical at 3 m

No	Frequency (MHz)	Emission Level (dBuV/m)	Limit (dBuV/m)	Margin (dB)	Antenna Height (m)	Table Angle (Degree)	Raw Value (dBuV)	Correction Factor (dB/m)
1	2390.00	58.9 PK	74.0	-15.1	1.95 V	153	61.6	-2.7
2	2390.00	44.6 AV	54.0	-9.4	1.95 V	153	47.3	-2.7
3	*2437.00	106.6 PK			1.95 V	153	109.3	-2.7
4	*2437.00	94.6 AV			1.95 V	153	97.3	-2.7
5	2483.50	63.8 PK	74.0	-10.2	1.95 V	153	66.6	-2.8
6	2483.50	47.3 AV	54.0	-6.7	1.95 V	153	50.1	-2.8
7	4874.00	43.2 PK	74.0	-30.8	2.58 V	347	41.5	1.7
8	4874.00	39.7 AV	54.0	-14.3	2.58 V	347	38.0	1.7
9	7311.00	46.2 PK	74.0	-27.8	1.22 V	136	39.0	7.2
10	7311.00	38.1 AV	54.0	-15.9	1.22 V	136	30.9	7.2

Remarks:

1. Emission Level(dBuV/m) = Raw Value(dBuV) + Correction Factor(dB/m)
2. Correction Factor(dB/m) = Antenna Factor(dB/m) + Cable Factor(dB) – Pre-Amplifier Factor(dB)
3. Margin value = Emission Level – Limit value
4. The other emission levels were very low against the limit.
5. " * ": Fundamental frequency.

RF Mode	TX 802.11ax (HE40)	Channel	CH 9 : 2452 MHz
Frequency Range	1GHz ~ 25GHz	Detector Function	Peak (PK) Average (AV)

Antenna Polarity & Test Distance : Horizontal at 3 m

No	Frequency (MHz)	Emission Level (dBuV/m)	Limit (dBuV/m)	Margin (dB)	Antenna Height (m)	Table Angle (Degree)	Raw Value (dBuV)	Correction Factor (dB/m)
1	*2452.00	107.3 PK			1.05 H	273	110.0	-2.7
2	*2452.00	95.1 AV			1.05 H	273	97.8	-2.7
3	2483.50	60.3 PK	74.0	-13.7	1.05 H	273	63.1	-2.8
4	2483.50	48.7 AV	54.0	-5.3	1.05 H	273	51.5	-2.8
5	4904.00	47.3 PK	74.0	-26.7	1.63 H	280	45.6	1.7
6	4904.00	45.2 AV	54.0	-8.8	1.63 H	280	43.5	1.7
7	7356.00	51.8 PK	74.0	-22.2	2.62 H	101	44.5	7.3
8	7356.00	48.0 AV	54.0	-6.0	2.62 H	101	40.7	7.3

Antenna Polarity & Test Distance : Vertical at 3 m

No	Frequency (MHz)	Emission Level (dBuV/m)	Limit (dBuV/m)	Margin (dB)	Antenna Height (m)	Table Angle (Degree)	Raw Value (dBuV)	Correction Factor (dB/m)
1	*2452.00	103.1 PK			1.93 V	164	105.8	-2.7
2	*2452.00	91.2 AV			1.93 V	164	93.9	-2.7
3	2483.50	58.9 PK	74.0	-15.1	1.93 V	164	61.7	-2.8
4	2483.50	46.1 AV	54.0	-7.9	1.93 V	164	48.9	-2.8
5	4904.00	43.4 PK	74.0	-30.6	2.52 V	340	41.7	1.7
6	4904.00	39.6 AV	54.0	-14.4	2.52 V	340	37.9	1.7
7	7356.00	46.2 PK	74.0	-27.8	1.19 V	126	38.9	7.3
8	7356.00	37.7 AV	54.0	-16.3	1.19 V	126	30.4	7.3

Remarks:

1. Emission Level(dBuV/m) = Raw Value(dBuV) + Correction Factor(dB/m)
2. Correction Factor(dB/m) = Antenna Factor(dB/m) + Cable Factor(dB) – Pre-Amplifier Factor(dB)
3. Margin value = Emission Level – Limit value
4. The other emission levels were very low against the limit.
5. " * ": Fundamental frequency.

RF Mode	TX 802.11ax (HE40)	Channel	CH 10 : 2457 MHz
Frequency Range	1GHz ~ 25GHz	Detector Function	Peak (PK) Average (AV)

Antenna Polarity & Test Distance : Horizontal at 3 m

No	Frequency (MHz)	Emission Level (dBuV/m)	Limit (dBuV/m)	Margin (dB)	Antenna Height (m)	Table Angle (Degree)	Raw Value (dBuV)	Correction Factor (dB/m)
1	*2457.00	104.3 PK			1.09 H	280	107.0	-2.7
2	*2457.00	92.3 AV			1.09 H	280	95.0	-2.7
3	2483.50	58.9 PK	74.0	-15.1	1.09 H	280	61.7	-2.8
4	2483.50	45.9 AV	54.0	-8.1	1.09 H	280	48.7	-2.8
5	4914.00	46.6 PK	74.0	-27.4	1.56 H	281	44.9	1.7
6	4914.00	44.7 AV	54.0	-9.3	1.56 H	281	43.0	1.7
7	7371.00	51.8 PK	74.0	-22.2	2.70 H	82	44.5	7.3
8	7371.00	48.0 AV	54.0	-6.0	2.70 H	82	40.7	7.3

Antenna Polarity & Test Distance : Vertical at 3 m

No	Frequency (MHz)	Emission Level (dBuV/m)	Limit (dBuV/m)	Margin (dB)	Antenna Height (m)	Table Angle (Degree)	Raw Value (dBuV)	Correction Factor (dB/m)
1	*2457.00	100.4 PK			1.95 V	137	103.1	-2.7
2	*2457.00	88.6 AV			1.95 V	137	91.3	-2.7
3	2483.50	56.6 PK	74.0	-17.4	1.95 V	137	59.4	-2.8
4	2483.50	44.4 AV	54.0	-9.6	1.95 V	137	47.2	-2.8
5	4914.00	43.4 PK	74.0	-30.6	2.54 V	341	41.7	1.7
6	4914.00	39.7 AV	54.0	-14.3	2.54 V	341	38.0	1.7
7	7371.00	46.7 PK	74.0	-27.3	1.18 V	129	39.4	7.3
8	7371.00	38.3 AV	54.0	-15.7	1.18 V	129	31.0	7.3

Remarks:

1. Emission Level(dBuV/m) = Raw Value(dBuV) + Correction Factor(dB/m)
2. Correction Factor(dB/m) = Antenna Factor(dB/m) + Cable Factor(dB) – Pre-Amplifier Factor(dB)
3. Margin value = Emission Level – Limit value
4. The other emission levels were very low against the limit.
5. " * ": Fundamental frequency.

RF Mode	TX 802.11ax (HE40)	Channel	CH 11 : 2462 MHz
Frequency Range	1GHz ~ 25GHz	Detector Function	Peak (PK) Average (AV)

Antenna Polarity & Test Distance : Horizontal at 3 m

No	Frequency (MHz)	Emission Level (dBuV/m)	Limit (dBuV/m)	Margin (dB)	Antenna Height (m)	Table Angle (Degree)	Raw Value (dBuV)	Correction Factor (dB/m)
1	*2462.00	103.8 PK			1.14 H	270	106.6	-2.8
2	*2462.00	91.6 AV			1.14 H	270	94.4	-2.8
3	2483.50	57.7 PK	74.0	-16.3	1.14 H	270	60.5	-2.8
4	2483.50	46.0 AV	54.0	-8.0	1.14 H	270	48.8	-2.8
5	4924.00	46.7 PK	74.0	-27.3	1.60 H	300	44.9	1.8
6	4924.00	44.6 AV	54.0	-9.4	1.60 H	300	42.8	1.8
7	7386.00	51.2 PK	74.0	-22.8	2.64 H	83	43.8	7.4
8	7386.00	47.9 AV	54.0	-6.1	2.64 H	83	40.5	7.4

Antenna Polarity & Test Distance : Vertical at 3 m

No	Frequency (MHz)	Emission Level (dBuV/m)	Limit (dBuV/m)	Margin (dB)	Antenna Height (m)	Table Angle (Degree)	Raw Value (dBuV)	Correction Factor (dB/m)
1	*2462.00	99.5 PK			1.88 V	150	102.3	-2.8
2	*2462.00	87.9 AV			1.88 V	150	90.7	-2.8
3	2483.50	55.8 PK	74.0	-18.2	1.88 V	150	58.6	-2.8
4	2483.50	43.9 AV	54.0	-10.1	1.88 V	150	46.7	-2.8
5	4924.00	43.6 PK	74.0	-30.4	2.58 V	347	41.8	1.8
6	4924.00	40.0 AV	54.0	-14.0	2.58 V	347	38.2	1.8
7	7386.00	46.4 PK	74.0	-27.6	1.24 V	143	39.0	7.4
8	7386.00	37.9 AV	54.0	-16.1	1.24 V	143	30.5	7.4

Remarks:

1. Emission Level(dBuV/m) = Raw Value(dBuV) + Correction Factor(dB/m)
2. Correction Factor(dB/m) = Antenna Factor(dB/m) + Cable Factor(dB) – Pre-Amplifier Factor(dB)
3. Margin value = Emission Level – Limit value
4. The other emission levels were very low against the limit.
5. " * ": Fundamental frequency.

RF Mode	TX 20MHz Preamble 802.11ax (RU26)	Channel	CH 1 : 2412 MHz
Frequency Range	1GHz ~ 25GHz	Detector Function	Peak (PK) Average (AV)

Antenna Polarity & Test Distance : Horizontal at 3 m

No	Frequency (MHz)	Emission Level (dBuV/m)	Limit (dBuV/m)	Margin (dB)	Antenna Height (m)	Table Angle (Degree)	Raw Value (dBuV)	Correction Factor (dB/m)
1	2387.15	63.7 PK	74.0	-10.3	2.95 H	116	66.4	-2.7
2	2387.15	47.3 AV	54.0	-6.7	2.95 H	116	50.0	-2.7
3	2388.78	72.5 PK	74.0	-1.5	2.95 H	116	75.2	-2.7
4	2388.78	46.8 AV	54.0	-7.2	2.95 H	116	49.5	-2.7
5	*2412.00	124.1 PK			2.95 H	116	126.8	-2.7
6	*2412.00	112.8 AV			2.95 H	116	115.5	-2.7
7	4824.00	49.9 PK	74.0	-24.1	1.35 H	297	48.1	1.8
8	4824.00	37.7 AV	54.0	-16.3	1.35 H	297	35.9	1.8

Antenna Polarity & Test Distance : Vertical at 3 m

No	Frequency (MHz)	Emission Level (dBuV/m)	Limit (dBuV/m)	Margin (dB)	Antenna Height (m)	Table Angle (Degree)	Raw Value (dBuV)	Correction Factor (dB/m)
1	2388.32	65.5 PK	74.0	-8.5	2.10 V	142	68.2	-2.7
2	2388.32	43.9 AV	54.0	-10.1	2.10 V	142	46.6	-2.7
3	*2412.00	116.5 PK			2.10 V	142	119.2	-2.7
4	*2412.00	104.9 AV			2.10 V	142	107.6	-2.7
5	4824.00	45.4 PK	74.0	-28.6	1.43 V	50	43.6	1.8
6	4824.00	33.8 AV	54.0	-20.2	1.43 V	50	32.0	1.8

Remarks:

1. Emission Level(dBuV/m) = Raw Value(dBuV) + Correction Factor(dB/m)
2. Correction Factor(dB/m) = Antenna Factor(dB/m) + Cable Factor(dB) – Pre-Amplifier Factor(dB)
3. Margin value = Emission Level – Limit value
4. The other emission levels were very low against the limit.
5. " * " : Fundamental frequency.

RF Mode	TX 20MHz Preamble 802.11ax (RU26)	Channel	CH 6 : 2437 MHz
Frequency Range	1GHz ~ 25GHz	Detector Function	Peak (PK) Average (AV)

Antenna Polarity & Test Distance : Horizontal at 3 m

No	Frequency (MHz)	Emission Level (dBuV/m)	Limit (dBuV/m)	Margin (dB)	Antenna Height (m)	Table Angle (Degree)	Raw Value (dBuV)	Correction Factor (dB/m)
1	2390.00	56.0 PK	74.0	-18.0	2.93 H	128	58.7	-2.7
2	2390.00	43.6 AV	54.0	-10.4	2.93 H	128	46.3	-2.7
3	*2437.00	128.3 PK			2.93 H	128	131.0	-2.7
4	*2437.00	115.4 AV			2.93 H	128	118.1	-2.7
5	2483.50	59.9 PK	74.0	-14.1	2.93 H	128	62.7	-2.8
6	2483.50	45.6 AV	54.0	-8.4	2.93 H	128	48.4	-2.8
7	4874.00	50.2 PK	74.0	-23.8	1.43 H	284	48.5	1.7
8	4874.00	37.7 AV	54.0	-16.3	1.43 H	284	36.0	1.7
9	7311.00	66.6 PK	74.0	-7.4	2.60 H	88	59.4	7.2
10	7311.00	50.7 AV	54.0	-3.3	2.60 H	88	43.5	7.2

Antenna Polarity & Test Distance : Vertical at 3 m

No	Frequency (MHz)	Emission Level (dBuV/m)	Limit (dBuV/m)	Margin (dB)	Antenna Height (m)	Table Angle (Degree)	Raw Value (dBuV)	Correction Factor (dB/m)
1	2390.00	55.6 PK	74.0	-18.4	2.06 V	139	58.3	-2.7
2	2390.00	43.0 AV	54.0	-11.0	2.06 V	139	45.7	-2.7
3	*2437.00	119.2 PK			2.06 V	139	121.9	-2.7
4	*2437.00	107.5 AV			2.06 V	139	110.2	-2.7
5	2483.50	57.0 PK	74.0	-17.0	2.06 V	139	59.8	-2.8
6	2483.50	43.0 AV	54.0	-11.0	2.06 V	139	45.8	-2.8
7	4874.00	45.2 PK	74.0	-28.8	1.46 V	50	43.5	1.7
8	4874.00	33.7 AV	54.0	-20.3	1.46 V	50	32.0	1.7
9	7311.00	63.6 PK	74.0	-10.4	1.84 V	58	56.4	7.2
10	7311.00	47.9 AV	54.0	-6.1	1.84 V	58	40.7	7.2

Remarks:

1. Emission Level(dBuV/m) = Raw Value(dBuV) + Correction Factor(dB/m)
2. Correction Factor(dB/m) = Antenna Factor(dB/m) + Cable Factor(dB) – Pre-Amplifier Factor(dB)
3. Margin value = Emission Level – Limit value
4. The other emission levels were very low against the limit.
5. " * ": Fundamental frequency.

RF Mode	TX 20MHz Preamble 802.11ax (RU26)	Channel	CH 11 : 2462 MHz
Frequency Range	1GHz ~ 25GHz	Detector Function	Peak (PK) Average (AV)

Antenna Polarity & Test Distance : Horizontal at 3 m

No	Frequency (MHz)	Emission Level (dBuV/m)	Limit (dBuV/m)	Margin (dB)	Antenna Height (m)	Table Angle (Degree)	Raw Value (dBuV)	Correction Factor (dB/m)
1	*2462.00	126.1 PK			2.50 H	107	128.9	-2.8
2	*2462.00	112.9 AV			2.50 H	107	115.7	-2.8
3	2485.94	72.4 PK	74.0	-1.6	2.50 H	107	75.2	-2.8
4	2485.94	47.0 AV	54.0	-7.0	2.50 H	107	49.8	-2.8
5	4924.00	50.0 PK	74.0	-24.0	1.34 H	293	48.2	1.8
6	4924.00	37.5 AV	54.0	-16.5	1.34 H	293	35.7	1.8
7	7386.00	66.1 PK	74.0	-7.9	2.67 H	86	58.7	7.4
8	7386.00	47.8 AV	54.0	-6.2	2.67 H	86	40.4	7.4

Antenna Polarity & Test Distance : Vertical at 3 m

No	Frequency (MHz)	Emission Level (dBuV/m)	Limit (dBuV/m)	Margin (dB)	Antenna Height (m)	Table Angle (Degree)	Raw Value (dBuV)	Correction Factor (dB/m)
1	*2462.00	116.1 PK			1.99 V	143	118.9	-2.8
2	*2462.00	104.2 AV			1.99 V	143	107.0	-2.8
3	2486.10	63.3 PK	74.0	-10.7	1.99 V	143	66.1	-2.8
4	2486.10	43.4 AV	54.0	-10.6	1.99 V	143	46.2	-2.8
5	4924.00	44.9 PK	74.0	-29.1	1.44 V	61	43.1	1.8
6	4924.00	33.2 AV	54.0	-20.8	1.44 V	61	31.4	1.8
7	7386.00	58.5 PK	74.0	-15.5	1.85 V	51	51.1	7.4
8	7386.00	43.7 AV	54.0	-10.3	1.85 V	51	36.3	7.4

Remarks:

1. Emission Level(dBuV/m) = Raw Value(dBuV) + Correction Factor(dB/m)
2. Correction Factor(dB/m) = Antenna Factor(dB/m) + Cable Factor(dB) – Pre-Amplifier Factor(dB)
3. Margin value = Emission Level – Limit value
4. The other emission levels were very low against the limit.
5. " * ": Fundamental frequency.

RF Mode	TX 20MHz Preamble 802.11ax (RU26)	Channel	CH 12 : 2467 MHz
Frequency Range	1GHz ~ 25GHz	Detector Function	Peak (PK) Average (AV)

Antenna Polarity & Test Distance : Horizontal at 3 m

No	Frequency (MHz)	Emission Level (dBuV/m)	Limit (dBuV/m)	Margin (dB)	Antenna Height (m)	Table Angle (Degree)	Raw Value (dBuV)	Correction Factor (dB/m)
1	*2467.00	123.1 PK			2.49 H	111	125.9	-2.8
2	*2467.00	110.4 AV			2.49 H	111	113.2	-2.8
3	2483.68	72.1 PK	74.0	-1.9	2.49 H	111	74.9	-2.8
4	2483.68	47.4 AV	54.0	-6.6	2.49 H	111	50.2	-2.8
5	4934.00	50.0 PK	74.0	-24.0	1.31 H	292	48.2	1.8
6	4934.00	37.4 AV	54.0	-16.6	1.31 H	292	35.6	1.8
7	7401.00	66.2 PK	74.0	-7.8	2.66 H	95	58.7	7.5
8	7401.00	48.1 AV	54.0	-5.9	2.66 H	95	40.6	7.5

Antenna Polarity & Test Distance : Vertical at 3 m

No	Frequency (MHz)	Emission Level (dBuV/m)	Limit (dBuV/m)	Margin (dB)	Antenna Height (m)	Table Angle (Degree)	Raw Value (dBuV)	Correction Factor (dB/m)
1	*2467.00	114.6 PK			2.01 V	138	117.4	-2.8
2	*2467.00	102.1 AV			2.01 V	138	104.9	-2.8
3	2484.00	64.0 PK	74.0	-10.0	2.01 V	138	66.8	-2.8
4	2484.00	43.7 AV	54.0	-10.3	2.01 V	138	46.5	-2.8
5	4934.00	44.3 PK	74.0	-29.7	1.47 V	75	42.5	1.8
6	4934.00	32.7 AV	54.0	-21.3	1.47 V	75	30.9	1.8
7	7401.00	58.7 PK	74.0	-15.3	1.88 V	53	51.2	7.5
8	7401.00	43.8 AV	54.0	-10.2	1.88 V	53	36.3	7.5

Remarks:

1. Emission Level(dBuV/m) = Raw Value(dBuV) + Correction Factor(dB/m)
2. Correction Factor(dB/m) = Antenna Factor(dB/m) + Cable Factor(dB) – Pre-Amplifier Factor(dB)
3. Margin value = Emission Level – Limit value
4. The other emission levels were very low against the limit.
5. " * ": Fundamental frequency.

RF Mode	TX 20MHz Preamble 802.11ax (RU26)	Channel	CH 13 : 2472 MHz
Frequency Range	1GHz ~ 25GHz	Detector Function	Peak (PK) Average (AV)

Antenna Polarity & Test Distance : Horizontal at 3 m

No	Frequency (MHz)	Emission Level (dBuV/m)	Limit (dBuV/m)	Margin (dB)	Antenna Height (m)	Table Angle (Degree)	Raw Value (dBuV)	Correction Factor (dB/m)
1	*2472.00	113.2 PK			1.25 H	330	116.0	-2.8
2	*2472.00	102.4 AV			1.25 H	330	105.2	-2.8
3	2483.50	72.3 PK	74.0	-1.7	1.25 H	330	75.1	-2.8
4	2483.50	48.3 AV	54.0	-5.7	1.25 H	330	51.1	-2.8
5	4944.00	49.6 PK	74.0	-24.4	1.31 H	298	47.8	1.8
6	4944.00	37.1 AV	54.0	-16.9	1.31 H	298	35.3	1.8
7	7416.00	65.9 PK	74.0	-8.1	2.71 H	82	58.4	7.5
8	7416.00	47.9 AV	54.0	-6.1	2.71 H	82	40.4	7.5

Antenna Polarity & Test Distance : Vertical at 3 m

No	Frequency (MHz)	Emission Level (dBuV/m)	Limit (dBuV/m)	Margin (dB)	Antenna Height (m)	Table Angle (Degree)	Raw Value (dBuV)	Correction Factor (dB/m)
1	*2472.00	113.0 PK			2.86 V	79	115.8	-2.8
2	*2472.00	100.7 AV			2.86 V	79	103.5	-2.8
3	2483.50	71.8 PK	74.0	-2.2	2.86 V	79	74.6	-2.8
4	2483.50	47.2 AV	54.0	-6.8	2.86 V	79	50.0	-2.8
5	4944.00	45.3 PK	74.0	-28.7	1.45 V	57	43.5	1.8
6	4944.00	33.7 AV	54.0	-20.3	1.45 V	57	31.9	1.8
7	7416.00	58.3 PK	74.0	-15.7	1.84 V	46	50.8	7.5
8	7416.00	43.6 AV	54.0	-10.4	1.84 V	46	36.1	7.5

Remarks:

1. Emission Level(dBuV/m) = Raw Value(dBuV) + Correction Factor(dB/m)
2. Correction Factor(dB/m) = Antenna Factor(dB/m) + Cable Factor(dB) – Pre-Amplifier Factor(dB)
3. Margin value = Emission Level – Limit value
4. The other emission levels were very low against the limit.
5. " * ": Fundamental frequency.

RF Mode	TX 20MHz Preamble 802.11ax (RU52)	Channel	CH 1 : 2412 MHz
Frequency Range	1GHz ~ 25GHz	Detector Function	Peak (PK) Average (AV)

Antenna Polarity & Test Distance : Horizontal at 3 m

No	Frequency (MHz)	Emission Level (dBuV/m)	Limit (dBuV/m)	Margin (dB)	Antenna Height (m)	Table Angle (Degree)	Raw Value (dBuV)	Correction Factor (dB/m)
1	2386.88	72.4 PK	74.0	-1.6	2.74 H	108	75.1	-2.7
2	2386.88	48.5 AV	54.0	-5.5	2.74 H	108	51.2	-2.7
3	2390.00	63.6 PK	74.0	-10.4	2.74 H	108	66.3	-2.7
4	2390.00	49.2 AV	54.0	-4.8	2.74 H	108	51.9	-2.7
5	*2412.00	121.9 PK			2.74 H	108	124.6	-2.7
6	*2412.00	111.0 AV			2.74 H	108	113.7	-2.7
7	4824.00	50.1 PK	74.0	-23.9	1.36 H	290	48.3	1.8
8	4824.00	37.7 AV	54.0	-16.3	1.36 H	290	35.9	1.8

Antenna Polarity & Test Distance : Vertical at 3 m

No	Frequency (MHz)	Emission Level (dBuV/m)	Limit (dBuV/m)	Margin (dB)	Antenna Height (m)	Table Angle (Degree)	Raw Value (dBuV)	Correction Factor (dB/m)
1	2386.90	63.7 PK	74.0	-10.3	2.08 V	149	66.4	-2.7
2	2386.90	44.9 AV	54.0	-9.1	2.08 V	149	47.6	-2.7
3	*2412.00	116.8 PK			2.08 V	149	119.5	-2.7
4	*2412.00	104.4 AV			2.08 V	149	107.1	-2.7
5	4824.00	45.7 PK	74.0	-28.3	1.50 V	53	43.9	1.8
6	4824.00	34.1 AV	54.0	-19.9	1.50 V	53	32.3	1.8

Remarks:

1. Emission Level(dBuV/m) = Raw Value(dBuV) + Correction Factor(dB/m)
2. Correction Factor(dB/m) = Antenna Factor(dB/m) + Cable Factor(dB) – Pre-Amplifier Factor(dB)
3. Margin value = Emission Level – Limit value
4. The other emission levels were very low against the limit.
5. " * " : Fundamental frequency.

RF Mode	TX 20MHz Preamble 802.11ax (RU52)	Channel	CH 6 : 2437 MHz
Frequency Range	1GHz ~ 25GHz	Detector Function	Peak (PK) Average (AV)

Antenna Polarity & Test Distance : Horizontal at 3 m

No	Frequency (MHz)	Emission Level (dBuV/m)	Limit (dBuV/m)	Margin (dB)	Antenna Height (m)	Table Angle (Degree)	Raw Value (dBuV)	Correction Factor (dB/m)
1	2390.00	55.6 PK	74.0	-18.4	2.76 H	121	58.3	-2.7
2	2390.00	43.2 AV	54.0	-10.8	2.76 H	121	45.9	-2.7
3	*2437.00	123.8 PK			2.76 H	121	126.5	-2.7
4	*2437.00	112.6 AV			2.76 H	121	115.3	-2.7
5	2483.50	59.4 PK	74.0	-14.6	2.76 H	121	62.2	-2.8
6	2483.50	44.9 AV	54.0	-9.1	2.76 H	121	47.7	-2.8
7	4874.00	50.6 PK	74.0	-23.4	1.41 H	300	48.9	1.7
8	4874.00	38.1 AV	54.0	-15.9	1.41 H	300	36.4	1.7
9	7311.00	63.9 PK	74.0	-10.1	2.61 H	89	56.7	7.2
10	7311.00	50.8 AV	54.0	-3.2	2.61 H	89	43.6	7.2

Antenna Polarity & Test Distance : Vertical at 3 m

No	Frequency (MHz)	Emission Level (dBuV/m)	Limit (dBuV/m)	Margin (dB)	Antenna Height (m)	Table Angle (Degree)	Raw Value (dBuV)	Correction Factor (dB/m)
1	2390.00	55.9 PK	74.0	-18.1	2.03 V	163	58.6	-2.7
2	2390.00	43.5 AV	54.0	-10.5	2.03 V	163	46.2	-2.7
3	*2437.00	118.3 PK			2.03 V	163	121.0	-2.7
4	*2437.00	106.4 AV			2.03 V	163	109.1	-2.7
5	2483.50	57.0 PK	74.0	-17.0	2.03 V	163	59.8	-2.8
6	2483.50	43.3 AV	54.0	-10.7	2.03 V	163	46.1	-2.8
7	4874.00	44.7 PK	74.0	-29.3	1.45 V	50	43.0	1.7
8	4874.00	32.9 AV	54.0	-21.1	1.45 V	50	31.2	1.7
9	7311.00	58.2 PK	74.0	-15.8	1.91 V	48	51.0	7.2
10	7311.00	43.4 AV	54.0	-10.6	1.91 V	48	36.2	7.2

Remarks:

1. Emission Level(dBuV/m) = Raw Value(dBuV) + Correction Factor(dB/m)
2. Correction Factor(dB/m) = Antenna Factor(dB/m) + Cable Factor(dB) – Pre-Amplifier Factor(dB)
3. Margin value = Emission Level – Limit value
4. The other emission levels were very low against the limit.
5. " * " : Fundamental frequency.

RF Mode	TX 20MHz Preamble 802.11ax (RU52)	Channel	CH 11 : 2462 MHz
Frequency Range	1GHz ~ 25GHz	Detector Function	Peak (PK) Average (AV)

Antenna Polarity & Test Distance : Horizontal at 3 m

No	Frequency (MHz)	Emission Level (dBuV/m)	Limit (dBuV/m)	Margin (dB)	Antenna Height (m)	Table Angle (Degree)	Raw Value (dBuV)	Correction Factor (dB/m)
1	*2462.00	123.4 PK			2.70 H	116	126.2	-2.8
2	*2462.00	112.2 AV			2.70 H	116	115.0	-2.8
3	2483.50	72.2 PK	74.0	-1.8	2.70 H	116	75.0	-2.8
4	2483.50	49.6 AV	54.0	-4.4	2.70 H	116	52.4	-2.8
5	4924.00	49.7 PK	74.0	-24.3	1.30 H	304	47.9	1.8
6	4924.00	37.1 AV	54.0	-16.9	1.30 H	304	35.3	1.8
7	7386.00	66.7 PK	74.0	-7.3	2.65 H	100	59.3	7.4
8	7386.00	48.2 AV	54.0	-5.8	2.65 H	100	40.8	7.4

Antenna Polarity & Test Distance : Vertical at 3 m

No	Frequency (MHz)	Emission Level (dBuV/m)	Limit (dBuV/m)	Margin (dB)	Antenna Height (m)	Table Angle (Degree)	Raw Value (dBuV)	Correction Factor (dB/m)
1	*2462.00	116.5 PK			2.02 V	146	119.3	-2.8
2	*2462.00	104.1 AV			2.02 V	146	106.9	-2.8
3	2483.50	64.5 PK	74.0	-9.5	2.02 V	146	67.3	-2.8
4	2483.50	44.3 AV	54.0	-9.7	2.02 V	146	47.1	-2.8
5	4924.00	45.1 PK	74.0	-28.9	1.47 V	63	43.3	1.8
6	4924.00	33.4 AV	54.0	-20.6	1.47 V	63	31.6	1.8
7	7386.00	58.7 PK	74.0	-15.3	1.78 V	61	51.3	7.4
8	7386.00	44.0 AV	54.0	-10.0	1.78 V	61	36.6	7.4

Remarks:

1. Emission Level(dBuV/m) = Raw Value(dBuV) + Correction Factor(dB/m)
2. Correction Factor(dB/m) = Antenna Factor(dB/m) + Cable Factor(dB) – Pre-Amplifier Factor(dB)
3. Margin value = Emission Level – Limit value
4. The other emission levels were very low against the limit.
5. " * ": Fundamental frequency.

RF Mode	TX 20MHz Preamble 802.11ax (RU52)	Channel	CH 12 : 2467 MHz
Frequency Range	1GHz ~ 25GHz	Detector Function	Peak (PK) Average (AV)

Antenna Polarity & Test Distance : Horizontal at 3 m

No	Frequency (MHz)	Emission Level (dBuV/m)	Limit (dBuV/m)	Margin (dB)	Antenna Height (m)	Table Angle (Degree)	Raw Value (dBuV)	Correction Factor (dB/m)
1	*2467.00	118.1 PK			2.75 H	112	120.9	-2.8
2	*2467.00	106.7 AV			2.75 H	112	109.5	-2.8
3	2483.50	72.1 PK	74.0	-1.9	2.75 H	112	74.9	-2.8
4	2483.50	47.1 AV	54.0	-6.9	2.75 H	112	49.9	-2.8
5	4934.00	50.2 PK	74.0	-23.8	1.29 H	286	48.4	1.8
6	4934.00	38.0 AV	54.0	-16.0	1.29 H	286	36.2	1.8
7	7401.00	65.6 PK	74.0	-8.4	2.71 H	74	58.1	7.5
8	7401.00	47.3 AV	54.0	-6.7	2.71 H	74	39.8	7.5

Antenna Polarity & Test Distance : Vertical at 3 m

No	Frequency (MHz)	Emission Level (dBuV/m)	Limit (dBuV/m)	Margin (dB)	Antenna Height (m)	Table Angle (Degree)	Raw Value (dBuV)	Correction Factor (dB/m)
1	*2467.00	111.1 PK			1.97 V	139	113.9	-2.8
2	*2467.00	98.9 AV			1.97 V	139	101.7	-2.8
3	2483.50	62.7 PK	74.0	-11.3	1.97 V	139	65.5	-2.8
4	2483.50	43.9 AV	54.0	-10.1	1.97 V	139	46.7	-2.8
5	4934.00	45.1 PK	74.0	-28.9	1.41 V	41	43.3	1.8
6	4934.00	33.3 AV	54.0	-20.7	1.41 V	41	31.5	1.8
7	7401.00	57.9 PK	74.0	-16.1	1.80 V	56	50.4	7.5
8	7401.00	43.3 AV	54.0	-10.7	1.80 V	56	35.8	7.5

Remarks:

1. Emission Level(dBuV/m) = Raw Value(dBuV) + Correction Factor(dB/m)
2. Correction Factor(dB/m) = Antenna Factor(dB/m) + Cable Factor(dB) – Pre-Amplifier Factor(dB)
3. Margin value = Emission Level – Limit value
4. The other emission levels were very low against the limit.
5. " * ": Fundamental frequency.

RF Mode	TX 20MHz Preamble 802.11ax (RU52)	Channel	CH 13 : 2472 MHz
Frequency Range	1GHz ~ 25GHz	Detector Function	Peak (PK) Average (AV)

Antenna Polarity & Test Distance : Horizontal at 3 m

No	Frequency (MHz)	Emission Level (dBuV/m)	Limit (dBuV/m)	Margin (dB)	Antenna Height (m)	Table Angle (Degree)	Raw Value (dBuV)	Correction Factor (dB/m)
1	*2472.00	113.2 PK			1.18 H	331	116.0	-2.8
2	*2472.00	102.0 AV			1.18 H	331	104.8	-2.8
3	2483.50	62.2 PK	74.0	-11.8	1.18 H	331	65.0	-2.8
4	2483.50	49.1 AV	54.0	-4.9	1.18 H	331	51.9	-2.8
5	2483.90	72.5 PK	74.0	-1.5	1.18 H	331	75.3	-2.8
6	2483.90	47.2 AV	54.0	-6.8	1.18 H	331	50.0	-2.8
7	4944.00	50.0 PK	74.0	-24.0	1.33 H	289	48.2	1.8
8	4944.00	37.3 AV	54.0	-16.7	1.33 H	289	35.5	1.8
9	7416.00	66.3 PK	74.0	-7.7	2.73 H	80	58.8	7.5
10	7416.00	48.3 AV	54.0	-5.7	2.73 H	80	40.8	7.5

Antenna Polarity & Test Distance : Vertical at 3 m

No	Frequency (MHz)	Emission Level (dBuV/m)	Limit (dBuV/m)	Margin (dB)	Antenna Height (m)	Table Angle (Degree)	Raw Value (dBuV)	Correction Factor (dB/m)
1	*2472.00	111.2 PK			2.98 V	71	114.0	-2.8
2	*2472.00	99.8 AV			2.98 V	71	102.6	-2.8
3	2484.15	71.7 PK	74.0	-2.3	2.98 V	71	74.5	-2.8
4	2484.15	46.0 AV	54.0	-8.0	2.98 V	71	48.8	-2.8
5	4944.00	45.5 PK	74.0	-28.5	1.50 V	41	43.7	1.8
6	4944.00	33.8 AV	54.0	-20.2	1.50 V	41	32.0	1.8
7	7416.00	58.4 PK	74.0	-15.6	1.88 V	55	50.9	7.5
8	7416.00	43.7 AV	54.0	-10.3	1.88 V	55	36.2	7.5

Remarks:

1. Emission Level(dBuV/m) = Raw Value(dBuV) + Correction Factor(dB/m)
2. Correction Factor(dB/m) = Antenna Factor(dB/m) + Cable Factor(dB) – Pre-Amplifier Factor(dB)
3. Margin value = Emission Level – Limit value
4. The other emission levels were very low against the limit.
5. " * ": Fundamental frequency.

RF Mode	TX 20MHz Preamble 802.11ax (RU106)	Channel	CH 1 : 2412 MHz
Frequency Range	1GHz ~ 25GHz	Detector Function	Peak (PK) Average (AV)

Antenna Polarity & Test Distance : Horizontal at 3 m

No	Frequency (MHz)	Emission Level (dBuV/m)	Limit (dBuV/m)	Margin (dB)	Antenna Height (m)	Table Angle (Degree)	Raw Value (dBuV)	Correction Factor (dB/m)
1	2389.62	72.5 PK	74.0	-1.5	2.88 H	119	75.2	-2.7
2	2389.62	48.9 AV	54.0	-5.1	2.88 H	119	51.6	-2.7
3	*2412.00	121.6 PK			2.88 H	119	124.3	-2.7
4	*2412.00	109.7 AV			2.88 H	119	112.4	-2.7
5	4824.00	50.2 PK	74.0	-23.8	1.36 H	280	48.4	1.8
6	4824.00	37.7 AV	54.0	-16.3	1.36 H	280	35.9	1.8

Antenna Polarity & Test Distance : Vertical at 3 m

No	Frequency (MHz)	Emission Level (dBuV/m)	Limit (dBuV/m)	Margin (dB)	Antenna Height (m)	Table Angle (Degree)	Raw Value (dBuV)	Correction Factor (dB/m)
1	2390.00	60.0 PK	74.0	-14.0	1.99 V	137	62.7	-2.7
2	2390.00	44.9 AV	54.0	-9.1	1.99 V	137	47.6	-2.7
3	*2412.00	113.4 PK			1.99 V	137	116.1	-2.7
4	*2412.00	102.5 AV			1.99 V	137	105.2	-2.7
5	4824.00	45.2 PK	74.0	-28.8	1.41 V	52	43.4	1.8
6	4824.00	33.5 AV	54.0	-20.5	1.41 V	52	31.7	1.8

Remarks:

1. Emission Level(dBuV/m) = Raw Value(dBuV) + Correction Factor(dB/m)
2. Correction Factor(dB/m) = Antenna Factor(dB/m) + Cable Factor(dB) – Pre-Amplifier Factor(dB)
3. Margin value = Emission Level – Limit value
4. The other emission levels were very low against the limit.
5. " * ": Fundamental frequency.

RF Mode	TX 20MHz Preamble 802.11ax (RU106)	Channel	CH 6 : 2437 MHz
Frequency Range	1GHz ~ 25GHz	Detector Function	Peak (PK) Average (AV)

Antenna Polarity & Test Distance : Horizontal at 3 m

No	Frequency (MHz)	Emission Level (dBuV/m)	Limit (dBuV/m)	Margin (dB)	Antenna Height (m)	Table Angle (Degree)	Raw Value (dBuV)	Correction Factor (dB/m)
1	2390.00	55.9 PK	74.0	-18.1	1.34 H	324	58.6	-2.7
2	2390.00	43.7 AV	54.0	-10.3	1.34 H	324	46.4	-2.7
3	*2437.00	121.4 PK			1.34 H	324	124.1	-2.7
4	*2437.00	111.3 AV			1.34 H	324	114.0	-2.7
5	2483.50	59.4 PK	74.0	-14.6	1.34 H	324	62.2	-2.8
6	2483.50	45.1 AV	54.0	-8.9	1.34 H	324	47.9	-2.8
7	4874.00	50.2 PK	74.0	-23.8	1.36 H	269	48.5	1.7
8	4874.00	37.6 AV	54.0	-16.4	1.36 H	269	35.9	1.7
9	7311.00	62.5 PK	74.0	-11.5	2.58 H	88	55.3	7.2
10	7311.00	50.7 AV	54.0	-3.3	2.58 H	88	43.5	7.2

Antenna Polarity & Test Distance : Vertical at 3 m

No	Frequency (MHz)	Emission Level (dBuV/m)	Limit (dBuV/m)	Margin (dB)	Antenna Height (m)	Table Angle (Degree)	Raw Value (dBuV)	Correction Factor (dB/m)
1	2390.00	55.6 PK	74.0	-18.4	2.02 V	136	58.3	-2.7
2	2390.00	43.1 AV	54.0	-10.9	2.02 V	136	45.8	-2.7
3	*2437.00	115.6 PK			2.02 V	136	118.3	-2.7
4	*2437.00	104.3 AV			2.02 V	136	107.0	-2.7
5	2483.50	57.4 PK	74.0	-16.6	2.02 V	136	60.2	-2.8
6	2483.50	43.5 AV	54.0	-10.5	2.02 V	136	46.3	-2.8
7	4874.00	44.9 PK	74.0	-29.1	1.39 V	76	43.2	1.7
8	4874.00	32.9 AV	54.0	-21.1	1.39 V	76	31.2	1.7
9	7311.00	58.0 PK	74.0	-16.0	1.80 V	63	50.8	7.2
10	7311.00	43.3 AV	54.0	-10.7	1.80 V	63	36.1	7.2

Remarks:

1. Emission Level(dBuV/m) = Raw Value(dBuV) + Correction Factor(dB/m)
2. Correction Factor(dB/m) = Antenna Factor(dB/m) + Cable Factor(dB) – Pre-Amplifier Factor(dB)
3. Margin value = Emission Level – Limit value
4. The other emission levels were very low against the limit.
5. " * ": Fundamental frequency.

RF Mode	TX 20MHz Preamble 802.11ax (RU106)	Channel	CH 11 : 2462 MHz
Frequency Range	1GHz ~ 25GHz	Detector Function	Peak (PK) Average (AV)

Antenna Polarity & Test Distance : Horizontal at 3 m

No	Frequency (MHz)	Emission Level (dBuV/m)	Limit (dBuV/m)	Margin (dB)	Antenna Height (m)	Table Angle (Degree)	Raw Value (dBuV)	Correction Factor (dB/m)
1	*2462.00	121.4 PK			2.50 H	112	124.2	-2.8
2	*2462.00	110.0 AV			2.50 H	112	112.8	-2.8
3	2483.83	72.0 PK	74.0	-2.0	2.50 H	112	74.8	-2.8
4	2483.83	50.5 AV	54.0	-3.5	2.50 H	112	53.3	-2.8
5	4924.00	50.5 PK	74.0	-23.5	1.37 H	299	48.7	1.8
6	4924.00	38.0 AV	54.0	-16.0	1.37 H	299	36.2	1.8
7	7386.00	65.8 PK	74.0	-8.2	2.68 H	73	58.4	7.4
8	7386.00	47.7 AV	54.0	-6.3	2.68 H	73	40.3	7.4

Antenna Polarity & Test Distance : Vertical at 3 m

No	Frequency (MHz)	Emission Level (dBuV/m)	Limit (dBuV/m)	Margin (dB)	Antenna Height (m)	Table Angle (Degree)	Raw Value (dBuV)	Correction Factor (dB/m)
1	*2462.00	113.1 PK			2.00 V	144	115.9	-2.8
2	*2462.00	102.3 AV			2.00 V	144	105.1	-2.8
3	2484.70	64.3 PK	74.0	-9.7	2.00 V	144	67.1	-2.8
4	2484.70	45.1 AV	54.0	-8.9	2.00 V	144	47.9	-2.8
5	4924.00	44.9 PK	74.0	-29.1	1.50 V	59	43.1	1.8
6	4924.00	33.4 AV	54.0	-20.6	1.50 V	59	31.6	1.8
7	7386.00	58.5 PK	74.0	-15.5	1.80 V	57	51.1	7.4
8	7386.00	43.9 AV	54.0	-10.1	1.80 V	57	36.5	7.4

Remarks:

1. Emission Level(dBuV/m) = Raw Value(dBuV) + Correction Factor(dB/m)
2. Correction Factor(dB/m) = Antenna Factor(dB/m) + Cable Factor(dB) – Pre-Amplifier Factor(dB)
3. Margin value = Emission Level – Limit value
4. The other emission levels were very low against the limit.
5. " * ": Fundamental frequency.

RF Mode	TX 20MHz Preamble 802.11ax (RU106)	Channel	CH 12 : 2467 MHz
Frequency Range	1GHz ~ 25GHz	Detector Function	Peak (PK) Average (AV)

Antenna Polarity & Test Distance : Horizontal at 3 m

No	Frequency (MHz)	Emission Level (dBuV/m)	Limit (dBuV/m)	Margin (dB)	Antenna Height (m)	Table Angle (Degree)	Raw Value (dBuV)	Correction Factor (dB/m)
1	*2467.00	119.2 PK			2.52 H	109	122.0	-2.8
2	*2467.00	107.9 AV			2.52 H	109	110.7	-2.8
3	2483.76	72.4 PK	74.0	-1.6	2.52 H	109	75.2	-2.8
4	2483.76	51.6 AV	54.0	-2.4	2.52 H	109	54.4	-2.8
5	4934.00	50.5 PK	74.0	-23.5	1.28 H	308	48.7	1.8
6	4934.00	37.8 AV	54.0	-16.2	1.28 H	308	36.0	1.8
7	7401.00	66.5 PK	74.0	-7.5	2.64 H	88	59.0	7.5
8	7401.00	48.2 AV	54.0	-5.8	2.64 H	88	40.7	7.5

Antenna Polarity & Test Distance : Vertical at 3 m

No	Frequency (MHz)	Emission Level (dBuV/m)	Limit (dBuV/m)	Margin (dB)	Antenna Height (m)	Table Angle (Degree)	Raw Value (dBuV)	Correction Factor (dB/m)
1	*2467.00	110.7 PK			2.03 V	147	113.5	-2.8
2	*2467.00	99.8 AV			2.03 V	147	102.6	-2.8
3	2484.00	64.1 PK	74.0	-9.9	2.03 V	147	66.9	-2.8
4	2484.00	45.2 AV	54.0	-8.8	2.03 V	147	48.0	-2.8
5	4934.00	45.2 PK	74.0	-28.8	1.41 V	48	43.4	1.8
6	4934.00	33.8 AV	54.0	-20.2	1.41 V	48	32.0	1.8
7	7401.00	59.0 PK	74.0	-15.0	1.81 V	54	51.5	7.5
8	7401.00	44.0 AV	54.0	-10.0	1.81 V	54	36.5	7.5

Remarks:

1. Emission Level(dBuV/m) = Raw Value(dBuV) + Correction Factor(dB/m)
2. Correction Factor(dB/m) = Antenna Factor(dB/m) + Cable Factor(dB) – Pre-Amplifier Factor(dB)
3. Margin value = Emission Level – Limit value
4. The other emission levels were very low against the limit.
5. " * ": Fundamental frequency.

RF Mode	TX 20MHz Preamble 802.11ax (RU106)	Channel	CH 13 : 2472 MHz
Frequency Range	1GHz ~ 25GHz	Detector Function	Peak (PK) Average (AV)

Antenna Polarity & Test Distance : Horizontal at 3 m

No	Frequency (MHz)	Emission Level (dBuV/m)	Limit (dBuV/m)	Margin (dB)	Antenna Height (m)	Table Angle (Degree)	Raw Value (dBuV)	Correction Factor (dB/m)
1	*2472.00	111.7 PK			2.51 H	111	114.5	-2.8
2	*2472.00	100.8 AV			2.51 H	111	103.6	-2.8
3	2483.89	72.4 PK	74.0	-1.6	2.51 H	111	75.2	-2.8
4	2483.89	51.7 AV	54.0	-2.3	2.51 H	111	54.5	-2.8
5	4944.00	49.9 PK	74.0	-24.1	1.38 H	309	48.1	1.8
6	4944.00	37.1 AV	54.0	-16.9	1.38 H	309	35.3	1.8
7	7416.00	66.1 PK	74.0	-7.9	2.69 H	74	58.6	7.5
8	7416.00	48.0 AV	54.0	-6.0	2.69 H	74	40.5	7.5

Antenna Polarity & Test Distance : Vertical at 3 m

No	Frequency (MHz)	Emission Level (dBuV/m)	Limit (dBuV/m)	Margin (dB)	Antenna Height (m)	Table Angle (Degree)	Raw Value (dBuV)	Correction Factor (dB/m)
1	*2472.00	105.8 PK			2.07 V	146	108.6	-2.8
2	*2472.00	94.9 AV			2.07 V	146	97.7	-2.8
3	2483.50	65.0 PK	74.0	-9.0	2.07 V	146	67.8	-2.8
4	2483.50	45.7 AV	54.0	-8.3	2.07 V	146	48.5	-2.8
5	4944.00	45.3 PK	74.0	-28.7	1.51 V	43	43.5	1.8
6	4944.00	33.9 AV	54.0	-20.1	1.51 V	43	32.1	1.8
7	7416.00	58.0 PK	74.0	-16.0	1.87 V	32	50.5	7.5
8	7416.00	43.2 AV	54.0	-10.8	1.87 V	32	35.7	7.5

Remarks:

1. Emission Level(dBuV/m) = Raw Value(dBuV) + Correction Factor(dB/m)
2. Correction Factor(dB/m) = Antenna Factor(dB/m) + Cable Factor(dB) – Pre-Amplifier Factor(dB)
3. Margin value = Emission Level – Limit value
4. The other emission levels were very low against the limit.
5. " * ": Fundamental frequency.

Below 1GHz Data:

RF Mode	TX 802.11g	Channel	CH 6 : 2437 MHz
Frequency Range	9kHz ~ 1GHz	Detector Function	Quasi-Peak (QP)

Antenna Polarity & Test Distance : Horizontal at 3 m								
No	Frequency (MHz)	Emission Level (dBuV/m)	Limit (dBuV/m)	Margin (dB)	Antenna Height (m)	Table Angle (Degree)	Raw Value (dBuV)	Correction Factor (dB/m)
1	119.79	38.4 QP	43.5	-5.1	3.00 H	340	53.5	-15.1
2	167.31	35.5 QP	43.5	-8.0	2.00 H	133	48.6	-13.1
3	227.06	33.8 QP	46.0	-12.2	2.00 H	127	49.7	-15.9
4	299.38	35.3 QP	46.0	-10.7	1.50 H	89	47.6	-12.3
5	336.79	34.1 QP	46.0	-11.9	1.50 H	325	45.4	-11.3
6	574.55	26.4 QP	46.0	-19.6	1.50 H	120	32.6	-6.2

Remarks:

1. Emission Level(dBuV/m) = Raw Value(dBuV) + Correction Factor(dB/m)
2. Correction Factor(dB/m) = Antenna Factor(dB/m) + Cable Factor(dB) – Pre-Amplifier Factor(dB)
3. Margin value = Emission Level – Limit value
4. The other emission levels were very low against the limit of frequency range 30MHz~1000MHz.
5. The emission levels were very low against the limit of frequency range 9kHz~30MHz: the amplitude of spurious emissions attenuated more than 20 dB below the permissible value to be report.

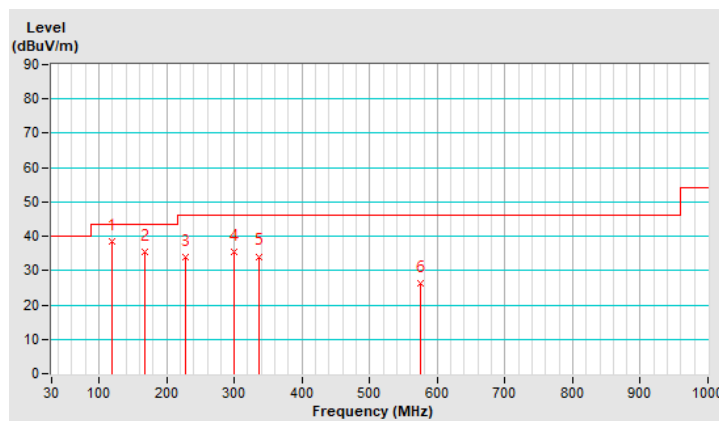

RF Mode	TX 802.11g	Channel	CH 6 : 2437 MHz
Frequency Range	9kHz ~ 1GHz	Detector Function	Quasi-Peak (QP)

Antenna Polarity & Test Distance : Vertical at 3 m								
No	Frequency (MHz)	Emission Level (dBuV/m)	Limit (dBuV/m)	Margin (dB)	Antenna Height (m)	Table Angle (Degree)	Raw Value (dBuV)	Correction Factor (dB/m)
1	125.39	28.6 QP	43.5	-14.9	1.00 V	26	43.1	-14.5
2	166.68	31.8 QP	43.5	-11.7	1.50 V	239	44.8	-13.0
3	224.18	31.6 QP	46.0	-14.4	1.00 V	123	47.6	-16.0
4	340.61	26.0 QP	46.0	-20.0	1.50 V	189	37.3	-11.3
5	498.65	24.4 QP	46.0	-21.6	1.50 V	37	32.1	-7.7
6	950.47	32.8 QP	46.0	-13.2	1.00 V	125	33.4	-0.6

Remarks:

1. Emission Level(dBuV/m) = Raw Value(dBuV) + Correction Factor(dB/m)
2. Correction Factor(dB/m) = Antenna Factor(dB/m) + Cable Factor(dB) – Pre-Amplifier Factor(dB)
3. Margin value = Emission Level – Limit value
4. The other emission levels were very low against the limit of frequency range 30MHz~1000MHz.
5. The emission levels were very low against the limit of frequency range 9kHz~30MHz: the amplitude of spurious emissions attenuated more than 20 dB below the permissible value to be report.

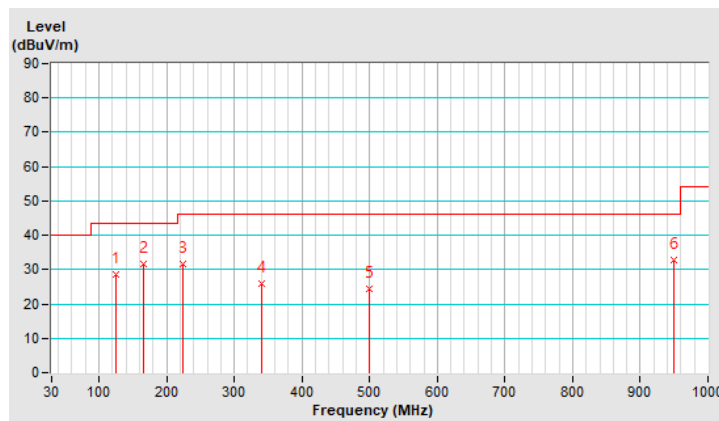

4.1.8 Test Results (Mode 2)

Dipole Antenna

Above 1GHz Data :

RF Mode	TX 802.11b	Channel	CH 1 : 2412 MHz
Frequency Range	1GHz ~ 25GHz	Detector Function	Peak (PK) Average (AV)

Antenna Polarity & Test Distance : Horizontal at 3 m								
No	Frequency (MHz)	Emission Level (dBuV/m)	Limit (dBuV/m)	Margin (dB)	Antenna Height (m)	Table Angle (Degree)	Raw Value (dBuV)	Correction Factor (dB/m)
1	2387.25	56.3 PK	74.0	-17.7	1.48 H	112	59.0	-2.7
2	2387.25	45.0 AV	54.0	-9.0	1.48 H	112	47.7	-2.7
3	*2412.00	99.3 PK			1.48 H	112	102.0	-2.7
4	*2412.00	96.9 AV			1.48 H	112	99.6	-2.7
5	4824.00	39.0 PK	74.0	-35.0	1.60 H	187	37.2	1.8
6	4824.00	34.2 AV	54.0	-19.8	1.60 H	187	32.4	1.8

Antenna Polarity & Test Distance : Vertical at 3 m								
No	Frequency (MHz)	Emission Level (dBuV/m)	Limit (dBuV/m)	Margin (dB)	Antenna Height (m)	Table Angle (Degree)	Raw Value (dBuV)	Correction Factor (dB/m)
1	2387.25	59.1 PK	74.0	-14.9	1.00 V	286	61.8	-2.7
2	2387.25	51.3 AV	54.0	-2.7	1.00 V	286	54.0	-2.7
3	*2412.00	111.7 PK			1.00 V	286	114.4	-2.7
4	*2412.00	109.5 AV			1.00 V	286	112.2	-2.7
5	4824.00	44.3 PK	74.0	-29.7	1.25 V	268	42.5	1.8
6	4824.00	40.5 AV	54.0	-13.5	1.25 V	268	38.7	1.8

Remarks:

1. Emission Level(dBuV/m) = Raw Value(dBuV) + Correction Factor(dB/m)
2. Correction Factor(dB/m) = Antenna Factor(dB/m) + Cable Factor(dB) – Pre-Amplifier Factor(dB)
3. Margin value = Emission Level – Limit value
4. The other emission levels were very low against the limit.
5. " * ": Fundamental frequency.

RF Mode	TX 802.11b	Channel	CH 6 : 2437 MHz
Frequency Range	1GHz ~ 25GHz	Detector Function	Peak (PK) Average (AV)

Antenna Polarity & Test Distance : Horizontal at 3 m

No	Frequency (MHz)	Emission Level (dBuV/m)	Limit (dBuV/m)	Margin (dB)	Antenna Height (m)	Table Angle (Degree)	Raw Value (dBuV)	Correction Factor (dB/m)
1	2390.00	52.4 PK	74.0	-21.6	1.51 H	114	55.1	-2.7
2	2390.00	38.6 AV	54.0	-15.4	1.51 H	114	41.3	-2.7
3	*2437.00	98.5 PK			1.51 H	114	101.2	-2.7
4	*2437.00	95.9 AV			1.51 H	114	98.6	-2.7
5	2483.50	55.1 PK	74.0	-18.9	1.51 H	114	57.9	-2.8
6	2483.50	40.1 AV	54.0	-13.9	1.51 H	114	42.9	-2.8
7	4874.00	39.3 PK	74.0	-34.7	1.65 H	176	37.6	1.7
8	4874.00	34.5 AV	54.0	-19.5	1.65 H	176	32.8	1.7
9	7311.00	45.4 PK	74.0	-28.6	1.97 H	195	38.2	7.2
10	7311.00	39.7 AV	54.0	-14.3	1.97 H	195	32.5	7.2

Antenna Polarity & Test Distance : Vertical at 3 m

No	Frequency (MHz)	Emission Level (dBuV/m)	Limit (dBuV/m)	Margin (dB)	Antenna Height (m)	Table Angle (Degree)	Raw Value (dBuV)	Correction Factor (dB/m)
1	2390.00	58.8 PK	74.0	-15.2	1.72 V	326	61.5	-2.7
2	2390.00	44.9 AV	54.0	-9.1	1.72 V	326	47.6	-2.7
3	*2437.00	110.6 PK			1.72 V	326	113.3	-2.7
4	*2437.00	109.1 AV			1.72 V	326	111.8	-2.7
5	2483.50	60.2 PK	74.0	-13.8	1.72 V	326	63.0	-2.8
6	2483.50	46.0 AV	54.0	-8.0	1.72 V	326	48.8	-2.8
7	4874.00	42.8 PK	74.0	-31.2	1.30 V	277	41.1	1.7
8	4874.00	38.4 AV	54.0	-15.6	1.30 V	277	36.7	1.7
9	7311.00	49.7 PK	74.0	-24.3	1.66 V	266	42.5	7.2
10	7311.00	44.3 AV	54.0	-9.7	1.66 V	266	37.1	7.2

Remarks:

1. Emission Level(dBuV/m) = Raw Value(dBuV) + Correction Factor(dB/m)
2. Correction Factor(dB/m) = Antenna Factor(dB/m) + Cable Factor(dB) – Pre-Amplifier Factor(dB)
3. Margin value = Emission Level – Limit value
4. The other emission levels were very low against the limit.
5. " * " : Fundamental frequency.

RF Mode	TX 802.11b	Channel	CH 11 : 2462 MHz
Frequency Range	1GHz ~ 25GHz	Detector Function	Peak (PK) Average (AV)

Antenna Polarity & Test Distance : Horizontal at 3 m

No	Frequency (MHz)	Emission Level (dBuV/m)	Limit (dBuV/m)	Margin (dB)	Antenna Height (m)	Table Angle (Degree)	Raw Value (dBuV)	Correction Factor (dB/m)
1	*2462.00	98.5 PK			1.24 H	219	101.3	-2.8
2	*2462.00	96.2 AV			1.24 H	219	99.0	-2.8
3	2488.00	55.5 PK	74.0	-18.5	1.24 H	219	58.3	-2.8
4	2488.00	43.6 AV	54.0	-10.4	1.24 H	219	46.4	-2.8
5	4924.00	39.4 PK	74.0	-34.6	1.68 H	180	37.6	1.8
6	4924.00	34.7 AV	54.0	-19.3	1.68 H	180	32.9	1.8
7	7386.00	45.0 PK	74.0	-29.0	1.95 H	191	37.6	7.4
8	7386.00	39.3 AV	54.0	-14.7	1.95 H	191	31.9	7.4

Antenna Polarity & Test Distance : Vertical at 3 m

No	Frequency (MHz)	Emission Level (dBuV/m)	Limit (dBuV/m)	Margin (dB)	Antenna Height (m)	Table Angle (Degree)	Raw Value (dBuV)	Correction Factor (dB/m)
1	*2462.00	111.6 PK			1.69 V	307	114.4	-2.8
2	*2462.00	109.3 AV			1.69 V	307	112.1	-2.8
3	2488.00	60.2 PK	74.0	-13.8	1.69 V	307	63.0	-2.8
4	2488.00	52.5 AV	54.0	-1.5	1.69 V	307	55.3	-2.8
5	4924.00	44.0 PK	74.0	-30.0	1.16 V	288	42.2	1.8
6	4924.00	40.0 AV	54.0	-14.0	1.16 V	288	38.2	1.8
7	7386.00	50.4 PK	74.0	-23.6	1.50 V	278	43.0	7.4
8	7386.00	43.9 AV	54.0	-10.1	1.50 V	278	36.5	7.4

Remarks:

1. Emission Level(dBuV/m) = Raw Value(dBuV) + Correction Factor(dB/m)
2. Correction Factor(dB/m) = Antenna Factor(dB/m) + Cable Factor(dB) – Pre-Amplifier Factor(dB)
3. Margin value = Emission Level – Limit value
4. The other emission levels were very low against the limit.
5. " * ": Fundamental frequency.

RF Mode	TX 802.11b	Channel	CH 12 : 2467 MHz
Frequency Range	1GHz ~ 25GHz	Detector Function	Peak (PK) Average (AV)

Antenna Polarity & Test Distance : Horizontal at 3 m

No	Frequency (MHz)	Emission Level (dBuV/m)	Limit (dBuV/m)	Margin (dB)	Antenna Height (m)	Table Angle (Degree)	Raw Value (dBuV)	Correction Factor (dB/m)
1	*2467.00	95.2 PK			1.22 H	215	98.0	-2.8
2	*2467.00	93.0 AV			1.22 H	215	95.8	-2.8
3	2483.50	56.6 PK	74.0	-17.4	1.22 H	215	59.4	-2.8
4	2483.50	44.8 AV	54.0	-9.2	1.22 H	215	47.6	-2.8
5	4934.00	39.1 PK	74.0	-34.9	1.70 H	164	37.3	1.8
6	4934.00	34.6 AV	54.0	-19.4	1.70 H	164	32.8	1.8
7	7401.00	46.1 PK	74.0	-27.9	2.01 H	210	38.6	7.5
8	7401.00	40.2 AV	54.0	-13.8	2.01 H	210	32.7	7.5

Antenna Polarity & Test Distance : Vertical at 3 m

No	Frequency (MHz)	Emission Level (dBuV/m)	Limit (dBuV/m)	Margin (dB)	Antenna Height (m)	Table Angle (Degree)	Raw Value (dBuV)	Correction Factor (dB/m)
1	*2467.00	108.4 PK			1.64 V	306	111.2	-2.8
2	*2467.00	106.1 AV			1.64 V	306	108.9	-2.8
3	2485.21	59.9 PK	74.0	-14.1	1.64 V	306	62.7	-2.8
4	2485.21	52.1 AV	54.0	-1.9	1.64 V	306	54.9	-2.8
5	4934.00	42.7 PK	74.0	-31.3	1.34 V	269	40.9	1.8
6	4934.00	38.3 AV	54.0	-15.7	1.34 V	269	36.5	1.8
7	7401.00	50.1 PK	74.0	-23.9	1.66 V	267	42.6	7.5
8	7401.00	44.4 AV	54.0	-9.6	1.66 V	267	36.9	7.5

Remarks:

1. Emission Level(dBuV/m) = Raw Value(dBuV) + Correction Factor(dB/m)
2. Correction Factor(dB/m) = Antenna Factor(dB/m) + Cable Factor(dB) – Pre-Amplifier Factor(dB)
3. Margin value = Emission Level – Limit value
4. The other emission levels were very low against the limit.
5. " * ": Fundamental frequency.

RF Mode	TX 802.11b	Channel	CH 13 : 2472 MHz
Frequency Range	1GHz ~ 25GHz	Detector Function	Peak (PK) Average (AV)

Antenna Polarity & Test Distance : Horizontal at 3 m

No	Frequency (MHz)	Emission Level (dBuV/m)	Limit (dBuV/m)	Margin (dB)	Antenna Height (m)	Table Angle (Degree)	Raw Value (dBuV)	Correction Factor (dB/m)
1	*2472.00	91.1 PK			1.26 H	221	93.9	-2.8
2	*2472.00	89.4 AV			1.26 H	221	92.2	-2.8
3	2487.35	55.3 PK	74.0	-18.7	1.26 H	221	58.1	-2.8
4	2487.35	43.9 AV	54.0	-10.1	1.26 H	221	46.7	-2.8
5	4944.00	39.9 PK	74.0	-34.1	1.61 H	168	38.1	1.8
6	4944.00	34.9 AV	54.0	-19.1	1.61 H	168	33.1	1.8
7	7416.00	45.7 PK	74.0	-28.3	2.01 H	209	38.2	7.5
8	7416.00	40.2 AV	54.0	-13.8	2.01 H	209	32.7	7.5

Antenna Polarity & Test Distance : Vertical at 3 m

No	Frequency (MHz)	Emission Level (dBuV/m)	Limit (dBuV/m)	Margin (dB)	Antenna Height (m)	Table Angle (Degree)	Raw Value (dBuV)	Correction Factor (dB/m)
1	*2472.00	104.6 PK			1.63 V	303	107.4	-2.8
2	*2472.00	102.4 AV			1.63 V	303	105.2	-2.8
3	2486.72	58.7 PK	74.0	-15.3	1.63 V	303	61.5	-2.8
4	2486.72	51.8 AV	54.0	-2.2	1.63 V	303	54.6	-2.8
5	4944.00	43.3 PK	74.0	-30.7	1.26 V	285	41.5	1.8
6	4944.00	38.7 AV	54.0	-15.3	1.26 V	285	36.9	1.8
7	7416.00	49.5 PK	74.0	-24.5	1.71 V	261	42.0	7.5
8	7416.00	43.8 AV	54.0	-10.2	1.71 V	261	36.3	7.5

Remarks:

1. Emission Level(dBuV/m) = Raw Value(dBuV) + Correction Factor(dB/m)
2. Correction Factor(dB/m) = Antenna Factor(dB/m) + Cable Factor(dB) – Pre-Amplifier Factor(dB)
3. Margin value = Emission Level – Limit value
4. The other emission levels were very low against the limit.
5. " * ": Fundamental frequency.

RF Mode	TX 802.11g	Channel	CH 1 : 2412 MHz
Frequency Range	1GHz ~ 25GHz	Detector Function	Peak (PK) Average (AV)

Antenna Polarity & Test Distance : Horizontal at 3 m

No	Frequency (MHz)	Emission Level (dBuV/m)	Limit (dBuV/m)	Margin (dB)	Antenna Height (m)	Table Angle (Degree)	Raw Value (dBuV)	Correction Factor (dB/m)
1	2390.00	64.4 PK	74.0	-9.6	1.00 H	149	67.1	-2.7
2	2390.00	47.6 AV	54.0	-6.4	1.00 H	149	50.3	-2.7
3	*2412.00	103.1 PK			1.00 H	149	105.8	-2.7
4	*2412.00	92.9 AV			1.00 H	149	95.6	-2.7
5	4824.00	39.5 PK	74.0	-34.5	1.64 H	164	37.7	1.8
6	4824.00	34.5 AV	54.0	-19.5	1.64 H	164	32.7	1.8

Antenna Polarity & Test Distance : Vertical at 3 m

No	Frequency (MHz)	Emission Level (dBuV/m)	Limit (dBuV/m)	Margin (dB)	Antenna Height (m)	Table Angle (Degree)	Raw Value (dBuV)	Correction Factor (dB/m)
1	2390.00	70.8 PK	74.0	-3.2	1.28 V	238	73.5	-2.7
2	2390.00	52.4 AV	54.0	-1.6	1.28 V	238	55.1	-2.7
3	*2412.00	112.8 PK			1.28 V	238	115.5	-2.7
4	*2412.00	103.8 AV			1.28 V	238	106.5	-2.7
5	4824.00	43.5 PK	74.0	-30.5	1.19 V	285	41.7	1.8
6	4824.00	38.8 AV	54.0	-15.2	1.19 V	285	37.0	1.8

Remarks:

1. Emission Level(dBuV/m) = Raw Value(dBuV) + Correction Factor(dB/m)
2. Correction Factor(dB/m) = Antenna Factor(dB/m) + Cable Factor(dB) – Pre-Amplifier Factor(dB)
3. Margin value = Emission Level – Limit value
4. The other emission levels were very low against the limit.
5. " * " : Fundamental frequency.

RF Mode	TX 802.11g	Channel	CH 6 : 2437 MHz
Frequency Range	1GHz ~ 25GHz	Detector Function	Peak (PK) Average (AV)

Antenna Polarity & Test Distance : Horizontal at 3 m

No	Frequency (MHz)	Emission Level (dBuV/m)	Limit (dBuV/m)	Margin (dB)	Antenna Height (m)	Table Angle (Degree)	Raw Value (dBuV)	Correction Factor (dB/m)
1	2390.00	52.7 PK	74.0	-21.3	1.05 H	153	55.4	-2.7
2	2390.00	39.1 AV	54.0	-14.9	1.05 H	153	41.8	-2.7
3	*2437.00	104.8 PK			1.05 H	153	107.5	-2.7
4	*2437.00	94.4 AV			1.05 H	153	97.1	-2.7
5	2483.50	55.3 PK	74.0	-18.7	1.05 H	153	58.1	-2.8
6	2483.50	40.1 AV	54.0	-13.9	1.05 H	153	42.9	-2.8
7	4874.00	39.4 PK	74.0	-34.6	1.65 H	160	37.7	1.7
8	4874.00	34.8 AV	54.0	-19.2	1.65 H	160	33.1	1.7
9	7311.00	45.6 PK	74.0	-28.4	1.98 H	207	38.4	7.2
10	7311.00	39.7 AV	54.0	-14.3	1.98 H	207	32.5	7.2

Antenna Polarity & Test Distance : Vertical at 3 m

No	Frequency (MHz)	Emission Level (dBuV/m)	Limit (dBuV/m)	Margin (dB)	Antenna Height (m)	Table Angle (Degree)	Raw Value (dBuV)	Correction Factor (dB/m)
1	2390.00	59.1 PK	74.0	-14.9	1.31 V	126	61.8	-2.7
2	2390.00	45.2 AV	54.0	-8.8	1.31 V	126	47.9	-2.7
3	*2437.00	115.6 PK			1.31 V	126	118.3	-2.7
4	*2437.00	105.1 AV			1.31 V	126	107.8	-2.7
5	2483.50	60.1 PK	74.0	-13.9	1.31 V	126	62.9	-2.8
6	2483.50	45.8 AV	54.0	-8.2	1.31 V	126	48.6	-2.8
7	4874.00	42.8 PK	74.0	-31.2	1.24 V	294	41.1	1.7
8	4874.00	38.3 AV	54.0	-15.7	1.24 V	294	36.6	1.7
9	7311.00	55.0 PK	74.0	-19.0	1.67 V	264	47.8	7.2
10	7311.00	41.1 AV	54.0	-12.9	1.67 V	264	33.9	7.2

Remarks:

1. Emission Level(dBuV/m) = Raw Value(dBuV) + Correction Factor(dB/m)
2. Correction Factor(dB/m) = Antenna Factor(dB/m) + Cable Factor(dB) – Pre-Amplifier Factor(dB)
3. Margin value = Emission Level – Limit value
4. The other emission levels were very low against the limit.
5. " * " : Fundamental frequency.

RF Mode	TX 802.11g	Channel	CH 11 : 2462 MHz
Frequency Range	1GHz ~ 25GHz	Detector Function	Peak (PK) Average (AV)

Antenna Polarity & Test Distance : Horizontal at 3 m

No	Frequency (MHz)	Emission Level (dBuV/m)	Limit (dBuV/m)	Margin (dB)	Antenna Height (m)	Table Angle (Degree)	Raw Value (dBuV)	Correction Factor (dB/m)
1	*2462.00	99.1 PK			1.24 H	221	101.9	-2.8
2	*2462.00	89.0 AV			1.24 H	221	91.8	-2.8
3	2483.50	60.1 PK	74.0	-13.9	1.24 H	221	62.9	-2.8
4	2483.50	44.8 AV	54.0	-9.2	1.24 H	221	47.6	-2.8
5	4924.00	39.7 PK	74.0	-34.3	1.65 H	165	37.9	1.8
6	4924.00	34.6 AV	54.0	-19.4	1.65 H	165	32.8	1.8
7	7386.00	45.5 PK	74.0	-28.5	1.93 H	194	38.1	7.4
8	7386.00	39.6 AV	54.0	-14.4	1.93 H	194	32.2	7.4

Antenna Polarity & Test Distance : Vertical at 3 m

No	Frequency (MHz)	Emission Level (dBuV/m)	Limit (dBuV/m)	Margin (dB)	Antenna Height (m)	Table Angle (Degree)	Raw Value (dBuV)	Correction Factor (dB/m)
1	*2462.00	112.9 PK			1.69 V	304	115.7	-2.8
2	*2462.00	103.8 AV			1.69 V	304	106.6	-2.8
3	2483.50	68.6 PK	74.0	-5.4	1.69 V	304	71.4	-2.8
4	2483.50	52.1 AV	54.0	-1.9	1.69 V	304	54.9	-2.8
5	4924.00	43.4 PK	74.0	-30.6	1.20 V	305	41.6	1.8
6	4924.00	38.7 AV	54.0	-15.3	1.20 V	305	36.9	1.8
7	7386.00	55.3 PK	74.0	-18.7	1.66 V	279	47.9	7.4
8	7386.00	41.1 AV	54.0	-12.9	1.66 V	279	33.7	7.4

Remarks:

1. Emission Level(dBuV/m) = Raw Value(dBuV) + Correction Factor(dB/m)
2. Correction Factor(dB/m) = Antenna Factor(dB/m) + Cable Factor(dB) – Pre-Amplifier Factor(dB)
3. Margin value = Emission Level – Limit value
4. The other emission levels were very low against the limit.
5. " * ": Fundamental frequency.

RF Mode	TX 802.11g	Channel	CH 12 : 2467 MHz
Frequency Range	1GHz ~ 25GHz	Detector Function	Peak (PK) Average (AV)

Antenna Polarity & Test Distance : Horizontal at 3 m

No	Frequency (MHz)	Emission Level (dBuV/m)	Limit (dBuV/m)	Margin (dB)	Antenna Height (m)	Table Angle (Degree)	Raw Value (dBuV)	Correction Factor (dB/m)
1	*2467.00	101.5 PK			1.44 H	112	104.3	-2.8
2	*2467.00	93.1 AV			1.44 H	112	95.9	-2.8
3	2483.50	55.8 PK	74.0	-18.2	1.44 H	112	58.6	-2.8
4	2483.50	44.2 AV	54.0	-9.8	1.44 H	112	47.0	-2.8
5	4934.00	38.9 PK	74.0	-35.1	1.59 H	176	37.1	1.8
6	4934.00	34.2 AV	54.0	-19.8	1.59 H	176	32.4	1.8
7	7401.00	45.6 PK	74.0	-28.4	1.96 H	203	38.1	7.5
8	7401.00	39.8 AV	54.0	-14.2	1.96 H	203	32.3	7.5

Antenna Polarity & Test Distance : Vertical at 3 m

No	Frequency (MHz)	Emission Level (dBuV/m)	Limit (dBuV/m)	Margin (dB)	Antenna Height (m)	Table Angle (Degree)	Raw Value (dBuV)	Correction Factor (dB/m)
1	*2467.00	106.2 PK			1.19 V	81	109.0	-2.8
2	*2467.00	96.1 AV			1.19 V	81	98.9	-2.8
3	2483.50	60.3 PK	74.0	-13.7	1.19 V	81	63.1	-2.8
4	2483.50	46.5 AV	54.0	-7.5	1.19 V	81	49.3	-2.8
5	4934.00	42.2 PK	74.0	-31.8	1.23 V	281	40.4	1.8
6	4934.00	37.9 AV	54.0	-16.1	1.23 V	281	36.1	1.8
7	7401.00	54.4 PK	74.0	-19.6	1.65 V	280	46.9	7.5
8	7401.00	40.6 AV	54.0	-13.4	1.65 V	280	33.1	7.5

Remarks:

1. Emission Level(dBuV/m) = Raw Value(dBuV) + Correction Factor(dB/m)
2. Correction Factor(dB/m) = Antenna Factor(dB/m) + Cable Factor(dB) – Pre-Amplifier Factor(dB)
3. Margin value = Emission Level – Limit value
4. The other emission levels were very low against the limit.
5. " * ": Fundamental frequency.

RF Mode	TX 802.11g	Channel	CH 13 : 2472 MHz
Frequency Range	1GHz ~ 25GHz	Detector Function	Peak (PK) Average (AV)

Antenna Polarity & Test Distance : Horizontal at 3 m

No	Frequency (MHz)	Emission Level (dBuV/m)	Limit (dBuV/m)	Margin (dB)	Antenna Height (m)	Table Angle (Degree)	Raw Value (dBuV)	Correction Factor (dB/m)
1	*2472.00	101.1 PK			1.50 H	123	103.9	-2.8
2	*2472.00	92.1 AV			1.50 H	123	94.9	-2.8
3	2483.50	57.2 PK	74.0	-16.8	1.50 H	123	60.0	-2.8
4	2483.50	44.4 AV	54.0	-9.6	1.50 H	123	47.2	-2.8
5	4944.00	39.8 PK	74.0	-34.2	1.65 H	173	38.0	1.8
6	4944.00	34.7 AV	54.0	-19.3	1.65 H	173	32.9	1.8
7	7416.00	45.5 PK	74.0	-28.5	2.02 H	185	38.0	7.5
8	7416.00	39.6 AV	54.0	-14.4	2.02 H	185	32.1	7.5

Antenna Polarity & Test Distance : Vertical at 3 m

No	Frequency (MHz)	Emission Level (dBuV/m)	Limit (dBuV/m)	Margin (dB)	Antenna Height (m)	Table Angle (Degree)	Raw Value (dBuV)	Correction Factor (dB/m)
1	*2472.00	104.8 PK			1.05 V	84	107.6	-2.8
2	*2472.00	94.8 AV			1.05 V	84	97.6	-2.8
3	2488.25	62.3 PK	74.0	-11.7	1.05 V	84	65.1	-2.8
4	2488.25	46.5 AV	54.0	-7.5	1.05 V	84	49.3	-2.8
5	4944.00	42.3 PK	74.0	-31.7	1.25 V	294	40.5	1.8
6	4944.00	38.0 AV	54.0	-16.0	1.25 V	294	36.2	1.8
7	7416.00	55.2 PK	74.0	-18.8	1.68 V	264	47.7	7.5
8	7416.00	41.0 AV	54.0	-13.0	1.68 V	264	33.5	7.5

Remarks:

1. Emission Level(dBuV/m) = Raw Value(dBuV) + Correction Factor(dB/m)
2. Correction Factor(dB/m) = Antenna Factor(dB/m) + Cable Factor(dB) – Pre-Amplifier Factor(dB)
3. Margin value = Emission Level – Limit value
4. The other emission levels were very low against the limit.
5. " * ": Fundamental frequency.

RF Mode	TX 802.11ax (HE20)	Channel	CH 1 : 2412 MHz
Frequency Range	1GHz ~ 25GHz	Detector Function	Peak (PK) Average (AV)

Antenna Polarity & Test Distance : Horizontal at 3 m

No	Frequency (MHz)	Emission Level (dBuV/m)	Limit (dBuV/m)	Margin (dB)	Antenna Height (m)	Table Angle (Degree)	Raw Value (dBuV)	Correction Factor (dB/m)
1	2390.00	65.1 PK	74.0	-8.9	1.05 H	153	67.8	-2.7
2	2390.00	49.5 AV	54.0	-4.5	1.05 H	153	52.2	-2.7
3	*2412.00	105.1 PK			1.05 H	153	107.8	-2.7
4	*2412.00	92.6 AV			1.05 H	153	95.3	-2.7
5	4824.00	39.2 PK	74.0	-34.8	1.65 H	171	37.4	1.8
6	4824.00	34.3 AV	54.0	-19.7	1.65 H	171	32.5	1.8

Antenna Polarity & Test Distance : Vertical at 3 m

No	Frequency (MHz)	Emission Level (dBuV/m)	Limit (dBuV/m)	Margin (dB)	Antenna Height (m)	Table Angle (Degree)	Raw Value (dBuV)	Correction Factor (dB/m)
1	2390.00	69.1 PK	74.0	-4.9	1.26 V	235	71.8	-2.7
2	2390.00	52.2 AV	54.0	-1.8	1.26 V	235	54.9	-2.7
3	*2412.00	114.8 PK			1.26 V	235	117.5	-2.7
4	*2412.00	103.7 AV			1.26 V	235	106.4	-2.7
5	4824.00	42.8 PK	74.0	-31.2	1.19 V	285	41.0	1.8
6	4824.00	38.3 AV	54.0	-15.7	1.19 V	285	36.5	1.8

Remarks:

1. Emission Level(dBuV/m) = Raw Value(dBuV) + Correction Factor(dB/m)
2. Correction Factor(dB/m) = Antenna Factor(dB/m) + Cable Factor(dB) – Pre-Amplifier Factor(dB)
3. Margin value = Emission Level – Limit value
4. The other emission levels were very low against the limit.
5. " * " : Fundamental frequency.

RF Mode	TX 802.11ax (HE20)	Channel	CH 6 : 2437 MHz
Frequency Range	1GHz ~ 25GHz	Detector Function	Peak (PK) Average (AV)

Antenna Polarity & Test Distance : Horizontal at 3 m

No	Frequency (MHz)	Emission Level (dBuV/m)	Limit (dBuV/m)	Margin (dB)	Antenna Height (m)	Table Angle (Degree)	Raw Value (dBuV)	Correction Factor (dB/m)
1	2390.00	52.3 PK	74.0	-21.7	1.10 H	166	55.0	-2.7
2	2390.00	38.6 AV	54.0	-15.4	1.10 H	166	41.3	-2.7
3	*2437.00	107.4 PK			1.10 H	166	110.1	-2.7
4	*2437.00	94.8 AV			1.10 H	166	97.5	-2.7
5	2483.50	54.9 PK	74.0	-19.1	1.10 H	166	57.7	-2.8
6	2483.50	40.2 AV	54.0	-13.8	1.10 H	166	43.0	-2.8
7	4874.00	39.9 PK	74.0	-34.1	1.66 H	182	38.2	1.7
8	4874.00	34.8 AV	54.0	-19.2	1.66 H	182	33.1	1.7
9	7311.00	45.9 PK	74.0	-28.1	1.99 H	181	38.7	7.2
10	7311.00	40.1 AV	54.0	-13.9	1.99 H	181	32.9	7.2

Antenna Polarity & Test Distance : Vertical at 3 m

No	Frequency (MHz)	Emission Level (dBuV/m)	Limit (dBuV/m)	Margin (dB)	Antenna Height (m)	Table Angle (Degree)	Raw Value (dBuV)	Correction Factor (dB/m)
1	2390.00	58.6 PK	74.0	-15.4	1.21 V	301	61.3	-2.7
2	2390.00	45.5 AV	54.0	-8.5	1.21 V	301	48.2	-2.7
3	*2437.00	116.2 PK			1.21 V	301	118.9	-2.7
4	*2437.00	105.2 AV			1.21 V	301	107.9	-2.7
5	2483.50	61.4 PK	74.0	-12.6	1.21 V	301	64.2	-2.8
6	2483.50	46.0 AV	54.0	-8.0	1.21 V	301	48.8	-2.8
7	4874.00	42.1 PK	74.0	-31.9	1.26 V	287	40.4	1.7
8	4874.00	37.8 AV	54.0	-16.2	1.26 V	287	36.1	1.7
9	7311.00	55.2 PK	74.0	-18.8	1.70 V	255	48.0	7.2
10	7311.00	41.3 AV	54.0	-12.7	1.70 V	255	34.1	7.2

Remarks:

1. Emission Level(dBuV/m) = Raw Value(dBuV) + Correction Factor(dB/m)
2. Correction Factor(dB/m) = Antenna Factor(dB/m) + Cable Factor(dB) – Pre-Amplifier Factor(dB)
3. Margin value = Emission Level – Limit value
4. The other emission levels were very low against the limit.
5. " * " : Fundamental frequency.

RF Mode	TX 802.11ax (HE20)	Channel	CH 11 : 2462 MHz
Frequency Range	1GHz ~ 25GHz	Detector Function	Peak (PK) Average (AV)

Antenna Polarity & Test Distance : Horizontal at 3 m

No	Frequency (MHz)	Emission Level (dBuV/m)	Limit (dBuV/m)	Margin (dB)	Antenna Height (m)	Table Angle (Degree)	Raw Value (dBuV)	Correction Factor (dB/m)
1	*2462.00	100.3 PK			1.25 H	219	103.1	-2.8
2	*2462.00	88.9 AV			1.25 H	219	91.7	-2.8
3	2483.50	58.3 PK	74.0	-15.7	1.25 H	219	61.1	-2.8
4	2483.50	45.2 AV	54.0	-8.8	1.25 H	219	48.0	-2.8
5	4924.00	39.2 PK	74.0	-34.8	1.63 H	173	37.4	1.8
6	4924.00	34.4 AV	54.0	-19.6	1.63 H	173	32.6	1.8
7	7386.00	45.6 PK	74.0	-28.4	2.01 H	194	38.2	7.4
8	7386.00	40.0 AV	54.0	-14.0	2.01 H	194	32.6	7.4

Antenna Polarity & Test Distance : Vertical at 3 m

No	Frequency (MHz)	Emission Level (dBuV/m)	Limit (dBuV/m)	Margin (dB)	Antenna Height (m)	Table Angle (Degree)	Raw Value (dBuV)	Correction Factor (dB/m)
1	*2462.00	114.2 PK			1.68 V	306	117.0	-2.8
2	*2462.00	102.9 AV			1.68 V	306	105.7	-2.8
3	2483.50	67.0 PK	74.0	-7.0	1.68 V	306	69.8	-2.8
4	2483.50	52.2 AV	54.0	-1.8	1.68 V	306	55.0	-2.8
5	4924.00	43.0 PK	74.0	-31.0	1.20 V	303	41.2	1.8
6	4924.00	38.5 AV	54.0	-15.5	1.20 V	303	36.7	1.8
7	7386.00	55.1 PK	74.0	-18.9	1.63 V	253	47.7	7.4
8	7386.00	41.0 AV	54.0	-13.0	1.63 V	253	33.6	7.4

Remarks:

1. Emission Level(dBuV/m) = Raw Value(dBuV) + Correction Factor(dB/m)
2. Correction Factor(dB/m) = Antenna Factor(dB/m) + Cable Factor(dB) – Pre-Amplifier Factor(dB)
3. Margin value = Emission Level – Limit value
4. The other emission levels were very low against the limit.
5. " * ": Fundamental frequency.

RF Mode	TX 802.11ax (HE20)	Channel	CH 12 : 2467 MHz
Frequency Range	1GHz ~ 25GHz	Detector Function	Peak (PK) Average (AV)

Antenna Polarity & Test Distance : Horizontal at 3 m

No	Frequency (MHz)	Emission Level (dBuV/m)	Limit (dBuV/m)	Margin (dB)	Antenna Height (m)	Table Angle (Degree)	Raw Value (dBuV)	Correction Factor (dB/m)
1	*2467.00	103.5 PK			1.50 H	116	106.3	-2.8
2	*2467.00	92.6 AV			1.50 H	116	95.4	-2.8
3	2483.50	56.3 PK	74.0	-17.7	1.50 H	116	59.1	-2.8
4	2483.50	44.1 AV	54.0	-9.9	1.50 H	116	46.9	-2.8
5	4934.00	39.4 PK	74.0	-34.6	1.66 H	191	37.6	1.8
6	4934.00	34.5 AV	54.0	-19.5	1.66 H	191	32.7	1.8
7	7401.00	45.9 PK	74.0	-28.1	2.03 H	193	38.4	7.5
8	7401.00	39.9 AV	54.0	-14.1	2.03 H	193	32.4	7.5

Antenna Polarity & Test Distance : Vertical at 3 m

No	Frequency (MHz)	Emission Level (dBuV/m)	Limit (dBuV/m)	Margin (dB)	Antenna Height (m)	Table Angle (Degree)	Raw Value (dBuV)	Correction Factor (dB/m)
1	*2467.00	107.7 PK			1.01 V	76	110.5	-2.8
2	*2467.00	95.6 AV			1.01 V	76	98.4	-2.8
3	2483.50	62.6 PK	74.0	-11.4	1.01 V	76	65.4	-2.8
4	2483.50	47.3 AV	54.0	-6.7	1.01 V	76	50.1	-2.8
5	4934.00	42.8 PK	74.0	-31.2	1.29 V	292	41.0	1.8
6	4934.00	38.2 AV	54.0	-15.8	1.29 V	292	36.4	1.8
7	7401.00	54.5 PK	74.0	-19.5	1.70 V	252	47.0	7.5
8	7401.00	40.6 AV	54.0	-13.4	1.70 V	252	33.1	7.5

Remarks:

1. Emission Level(dBuV/m) = Raw Value(dBuV) + Correction Factor(dB/m)
2. Correction Factor(dB/m) = Antenna Factor(dB/m) + Cable Factor(dB) – Pre-Amplifier Factor(dB)
3. Margin value = Emission Level – Limit value
4. The other emission levels were very low against the limit.
5. " * ": Fundamental frequency.

RF Mode	TX 802.11ax (HE20)	Channel	CH 13 : 2472 MHz
Frequency Range	1GHz ~ 25GHz	Detector Function	Peak (PK) Average (AV)

Antenna Polarity & Test Distance : Horizontal at 3 m

No	Frequency (MHz)	Emission Level (dBuV/m)	Limit (dBuV/m)	Margin (dB)	Antenna Height (m)	Table Angle (Degree)	Raw Value (dBuV)	Correction Factor (dB/m)
1	*2472.00	102.6 PK			1.59 H	122	105.4	-2.8
2	*2472.00	91.4 AV			1.59 H	122	94.2	-2.8
3	2483.50	61.8 PK	74.0	-12.2	1.59 H	122	64.6	-2.8
4	2483.50	44.0 AV	54.0	-10.0	1.59 H	122	46.8	-2.8
5	4944.00	39.5 PK	74.0	-34.5	1.70 H	173	37.7	1.8
6	4944.00	34.9 AV	54.0	-19.1	1.70 H	173	33.1	1.8
7	7416.00	45.5 PK	74.0	-28.5	2.01 H	193	38.0	7.5
8	7416.00	39.6 AV	54.0	-14.4	2.01 H	193	32.1	7.5

Antenna Polarity & Test Distance : Vertical at 3 m

No	Frequency (MHz)	Emission Level (dBuV/m)	Limit (dBuV/m)	Margin (dB)	Antenna Height (m)	Table Angle (Degree)	Raw Value (dBuV)	Correction Factor (dB/m)
1	*2472.00	106.1 PK			1.06 V	85	108.9	-2.8
2	*2472.00	94.5 AV			1.06 V	85	97.3	-2.8
3	2483.50	68.4 PK	74.0	-5.6	1.06 V	85	71.2	-2.8
4	2483.50	45.3 AV	54.0	-8.7	1.06 V	85	48.1	-2.8
5	4944.00	42.5 PK	74.0	-31.5	1.24 V	305	40.7	1.8
6	4944.00	38.0 AV	54.0	-16.0	1.24 V	305	36.2	1.8
7	7416.00	55.4 PK	74.0	-18.6	1.68 V	264	47.9	7.5
8	7416.00	41.3 AV	54.0	-12.7	1.68 V	264	33.8	7.5

Remarks:

1. Emission Level(dBuV/m) = Raw Value(dBuV) + Correction Factor(dB/m)
2. Correction Factor(dB/m) = Antenna Factor(dB/m) + Cable Factor(dB) – Pre-Amplifier Factor(dB)
3. Margin value = Emission Level – Limit value
4. The other emission levels were very low against the limit.
5. " * ": Fundamental frequency.

RF Mode	TX 802.11ax (HE40)	Channel	CH 3 : 2422 MHz
Frequency Range	1GHz ~ 25GHz	Detector Function	Peak (PK) Average (AV)

Antenna Polarity & Test Distance : Horizontal at 3 m

No	Frequency (MHz)	Emission Level (dBuV/m)	Limit (dBuV/m)	Margin (dB)	Antenna Height (m)	Table Angle (Degree)	Raw Value (dBuV)	Correction Factor (dB/m)
1	2388.00	65.2 PK	74.0	-8.8	1.03 H	148	67.9	-2.7
2	2388.00	46.8 AV	54.0	-7.2	1.03 H	148	49.5	-2.7
3	*2422.00	101.1 PK			1.03 H	148	103.8	-2.7
4	*2422.00	88.8 AV			1.03 H	148	91.5	-2.7
5	4844.00	38.9 PK	74.0	-35.1	1.60 H	173	37.1	1.8
6	4844.00	34.4 AV	54.0	-19.6	1.60 H	173	32.6	1.8
7	7266.00	44.9 PK	74.0	-29.1	1.95 H	192	37.6	7.3
8	7266.00	39.2 AV	54.0	-14.8	1.95 H	192	31.9	7.3

Antenna Polarity & Test Distance : Vertical at 3 m

No	Frequency (MHz)	Emission Level (dBuV/m)	Limit (dBuV/m)	Margin (dB)	Antenna Height (m)	Table Angle (Degree)	Raw Value (dBuV)	Correction Factor (dB/m)
1	2387.82	72.2 PK	74.0	-1.8	1.58 V	160	74.9	-2.7
2	2387.82	51.7 AV	54.0	-2.3	1.58 V	160	54.4	-2.7
3	*2422.00	111.1 PK			1.58 V	160	113.8	-2.7
4	*2422.00	99.5 AV			1.58 V	160	102.2	-2.7
5	4844.00	43.0 PK	74.0	-31.0	1.21 V	299	41.2	1.8
6	4844.00	38.2 AV	54.0	-15.8	1.21 V	299	36.4	1.8
7	7266.00	54.4 PK	74.0	-19.6	1.73 V	280	47.1	7.3
8	7266.00	40.7 AV	54.0	-13.3	1.73 V	280	33.4	7.3

Remarks:

1. Emission Level(dBuV/m) = Raw Value(dBuV) + Correction Factor(dB/m)
2. Correction Factor(dB/m) = Antenna Factor(dB/m) + Cable Factor(dB) – Pre-Amplifier Factor(dB)
3. Margin value = Emission Level – Limit value
4. The other emission levels were very low against the limit.
5. " * ": Fundamental frequency.

RF Mode	TX 802.11ax (HE40)	Channel	CH 6 : 2437 MHz
Frequency Range	1GHz ~ 25GHz	Detector Function	Peak (PK) Average (AV)

Antenna Polarity & Test Distance : Horizontal at 3 m

No	Frequency (MHz)	Emission Level (dBuV/m)	Limit (dBuV/m)	Margin (dB)	Antenna Height (m)	Table Angle (Degree)	Raw Value (dBuV)	Correction Factor (dB/m)
1	2390.00	62.0 PK	74.0	-12.0	1.01 H	159	64.7	-2.7
2	2390.00	44.5 AV	54.0	-9.5	1.01 H	159	47.2	-2.7
3	*2437.00	101.3 PK			1.01 H	159	104.0	-2.7
4	*2437.00	89.1 AV			1.01 H	159	91.8	-2.7
5	2483.50	62.3 PK	74.0	-11.7	1.01 H	159	65.1	-2.8
6	2483.50	45.5 AV	54.0	-8.5	1.01 H	159	48.3	-2.8
7	4874.00	39.3 PK	74.0	-34.7	1.70 H	175	37.6	1.7
8	4874.00	34.2 AV	54.0	-19.8	1.70 H	175	32.5	1.7
9	7311.00	45.7 PK	74.0	-28.3	1.95 H	185	38.5	7.2
10	7311.00	40.0 AV	54.0	-14.0	1.95 H	185	32.8	7.2

Antenna Polarity & Test Distance : Vertical at 3 m

No	Frequency (MHz)	Emission Level (dBuV/m)	Limit (dBuV/m)	Margin (dB)	Antenna Height (m)	Table Angle (Degree)	Raw Value (dBuV)	Correction Factor (dB/m)
1	2390.00	68.2 PK	74.0	-5.8	1.60 V	293	70.9	-2.7
2	2390.00	50.9 AV	54.0	-3.1	1.60 V	293	53.6	-2.7
3	*2437.00	110.9 PK			1.60 V	293	113.6	-2.7
4	*2437.00	98.9 AV			1.60 V	293	101.6	-2.7
5	2483.50	70.8 PK	74.0	-3.2	1.60 V	293	73.6	-2.8
6	2483.50	52.3 AV	54.0	-1.7	1.60 V	293	55.1	-2.8
7	4874.00	43.1 PK	74.0	-30.9	1.24 V	285	41.4	1.7
8	4874.00	38.4 AV	54.0	-15.6	1.24 V	285	36.7	1.7
9	7311.00	54.8 PK	74.0	-19.2	1.67 V	279	47.6	7.2
10	7311.00	40.8 AV	54.0	-13.2	1.67 V	279	33.6	7.2

Remarks:

1. Emission Level(dBuV/m) = Raw Value(dBuV) + Correction Factor(dB/m)
2. Correction Factor(dB/m) = Antenna Factor(dB/m) + Cable Factor(dB) – Pre-Amplifier Factor(dB)
3. Margin value = Emission Level – Limit value
4. The other emission levels were very low against the limit.
5. " * ": Fundamental frequency.

RF Mode	TX 802.11ax (HE40)	Channel	CH 9 : 2452 MHz
Frequency Range	1GHz ~ 25GHz	Detector Function	Peak (PK) Average (AV)

Antenna Polarity & Test Distance : Horizontal at 3 m

No	Frequency (MHz)	Emission Level (dBuV/m)	Limit (dBuV/m)	Margin (dB)	Antenna Height (m)	Table Angle (Degree)	Raw Value (dBuV)	Correction Factor (dB/m)
1	*2452.00	98.2 PK			1.05 H	220	100.9	-2.7
2	*2452.00	85.6 AV			1.05 H	220	88.3	-2.7
3	2488.64	56.8 PK	74.0	-17.2	1.05 H	220	59.6	-2.8
4	2488.64	43.7 AV	54.0	-10.3	1.05 H	220	46.5	-2.8
5	4904.00	38.9 PK	74.0	-35.1	1.69 H	161	37.2	1.7
6	4904.00	34.1 AV	54.0	-19.9	1.69 H	161	32.4	1.7
7	7356.00	46.0 PK	74.0	-28.0	1.91 H	206	38.7	7.3
8	7356.00	40.0 AV	54.0	-14.0	1.91 H	206	32.7	7.3

Antenna Polarity & Test Distance : Vertical at 3 m

No	Frequency (MHz)	Emission Level (dBuV/m)	Limit (dBuV/m)	Margin (dB)	Antenna Height (m)	Table Angle (Degree)	Raw Value (dBuV)	Correction Factor (dB/m)
1	*2452.00	110.7 PK			1.13 V	295	113.4	-2.7
2	*2452.00	98.6 AV			1.13 V	295	101.3	-2.7
3	2486.73	70.3 PK	74.0	-3.7	1.13 V	295	73.1	-2.8
4	2486.73	52.2 AV	54.0	-1.8	1.13 V	295	55.0	-2.8
5	2489.91	71.3 PK	74.0	-2.7	1.13 V	295	74.1	-2.8
6	2489.91	52.1 AV	54.0	-1.9	1.13 V	295	54.9	-2.8
7	4904.00	42.7 PK	74.0	-31.3	1.29 V	299	41.0	1.7
8	4904.00	38.4 AV	54.0	-15.6	1.29 V	299	36.7	1.7
9	7356.00	54.7 PK	74.0	-19.3	1.62 V	269	47.4	7.3
10	7356.00	40.6 AV	54.0	-13.4	1.62 V	269	33.3	7.3

Remarks:

1. Emission Level(dBuV/m) = Raw Value(dBuV) + Correction Factor(dB/m)
2. Correction Factor(dB/m) = Antenna Factor(dB/m) + Cable Factor(dB) – Pre-Amplifier Factor(dB)
3. Margin value = Emission Level – Limit value
4. The other emission levels were very low against the limit.
5. " * ": Fundamental frequency.

RF Mode	TX 802.11ax (HE40)	Channel	CH 10 : 2457 MHz
Frequency Range	1GHz ~ 25GHz	Detector Function	Peak (PK) Average (AV)

Antenna Polarity & Test Distance : Horizontal at 3 m

No	Frequency (MHz)	Emission Level (dBuV/m)	Limit (dBuV/m)	Margin (dB)	Antenna Height (m)	Table Angle (Degree)	Raw Value (dBuV)	Correction Factor (dB/m)
1	*2457.00	97.9 PK			1.06 H	215	100.6	-2.7
2	*2457.00	85.4 AV			1.06 H	215	88.1	-2.7
3	2493.27	59.0 PK	74.0	-15.0	1.06 H	215	61.8	-2.8
4	2493.27	43.9 AV	54.0	-10.1	1.06 H	215	46.7	-2.8
5	4914.00	39.0 PK	74.0	-35.0	1.67 H	184	37.3	1.7
6	4914.00	34.1 AV	54.0	-19.9	1.67 H	184	32.4	1.7
7	7371.00	45.6 PK	74.0	-28.4	2.01 H	180	38.3	7.3
8	7371.00	40.1 AV	54.0	-13.9	2.01 H	180	32.8	7.3

Antenna Polarity & Test Distance : Vertical at 3 m

No	Frequency (MHz)	Emission Level (dBuV/m)	Limit (dBuV/m)	Margin (dB)	Antenna Height (m)	Table Angle (Degree)	Raw Value (dBuV)	Correction Factor (dB/m)
1	*2457.00	110.6 PK			1.09 V	291	113.3	-2.7
2	*2457.00	98.2 AV			1.09 V	291	100.9	-2.7
3	2484.73	68.0 PK	74.0	-6.0	1.09 V	291	70.8	-2.8
4	2484.73	52.4 AV	54.0	-1.6	1.09 V	291	55.2	-2.8
5	2493.28	69.8 PK	74.0	-4.2	1.09 V	291	72.6	-2.8
6	2493.28	51.7 AV	54.0	-2.3	1.09 V	291	54.5	-2.8
7	4914.00	42.3 PK	74.0	-31.7	1.18 V	302	40.6	1.7
8	4914.00	37.8 AV	54.0	-16.2	1.18 V	302	36.1	1.7
9	7371.00	54.8 PK	74.0	-19.2	1.62 V	253	47.5	7.3
10	7371.00	41.1 AV	54.0	-12.9	1.62 V	253	33.8	7.3

Remarks:

1. Emission Level(dBuV/m) = Raw Value(dBuV) + Correction Factor(dB/m)
2. Correction Factor(dB/m) = Antenna Factor(dB/m) + Cable Factor(dB) – Pre-Amplifier Factor(dB)
3. Margin value = Emission Level – Limit value
4. The other emission levels were very low against the limit.
5. " * ": Fundamental frequency.

RF Mode	TX 802.11ax (HE40)	Channel	CH 11 : 2462 MHz
Frequency Range	1GHz ~ 25GHz	Detector Function	Peak (PK) Average (AV)

Antenna Polarity & Test Distance : Horizontal at 3 m

No	Frequency (MHz)	Emission Level (dBuV/m)	Limit (dBuV/m)	Margin (dB)	Antenna Height (m)	Table Angle (Degree)	Raw Value (dBuV)	Correction Factor (dB/m)
1	*2462.00	97.6 PK			1.10 H	210	100.4	-2.8
2	*2462.00	85.1 AV			1.10 H	210	87.9	-2.8
3	2488.53	61.5 PK	74.0	-12.5	1.10 H	210	64.3	-2.8
4	2488.53	44.8 AV	54.0	-9.2	1.10 H	210	47.6	-2.8
5	4924.00	39.6 PK	74.0	-34.4	1.66 H	169	37.8	1.8
6	4924.00	35.0 AV	54.0	-19.0	1.66 H	169	33.2	1.8
7	7386.00	45.3 PK	74.0	-28.7	2.00 H	206	37.9	7.4
8	7386.00	39.4 AV	54.0	-14.6	2.00 H	206	32.0	7.4

Antenna Polarity & Test Distance : Vertical at 3 m

No	Frequency (MHz)	Emission Level (dBuV/m)	Limit (dBuV/m)	Margin (dB)	Antenna Height (m)	Table Angle (Degree)	Raw Value (dBuV)	Correction Factor (dB/m)
1	*2462.00	1009.1 PK			1.22 V	237	1011.9	-2.8
2	*2462.00	97.0 AV			1.22 V	237	99.8	-2.8
3	2483.50	66.5 PK	74.0	-7.5	1.22 V	237	69.3	-2.8
4	2483.50	52.3 AV	54.0	-1.7	1.22 V	237	55.1	-2.8
5	4924.00	43.5 PK	74.0	-30.5	1.29 V	278	41.7	1.8
6	4924.00	38.8 AV	54.0	-15.2	1.29 V	278	37.0	1.8
7	7386.00	54.3 PK	74.0	-19.7	1.68 V	279	46.9	7.4
8	7386.00	40.6 AV	54.0	-13.4	1.68 V	279	33.2	7.4

Remarks:

1. Emission Level(dBuV/m) = Raw Value(dBuV) + Correction Factor(dB/m)
2. Correction Factor(dB/m) = Antenna Factor(dB/m) + Cable Factor(dB) – Pre-Amplifier Factor(dB)
3. Margin value = Emission Level – Limit value
4. The other emission levels were very low against the limit.
5. " * ": Fundamental frequency.

RF Mode	TX 20MHz Preamble 802.11ax (RU26)	Channel	CH 1 : 2412 MHz
Frequency Range	1GHz ~ 25GHz	Detector Function	Peak (PK) Average (AV)

Antenna Polarity & Test Distance : Horizontal at 3 m

No	Frequency (MHz)	Emission Level (dBuV/m)	Limit (dBuV/m)	Margin (dB)	Antenna Height (m)	Table Angle (Degree)	Raw Value (dBuV)	Correction Factor (dB/m)
1	2386.80	60.1 PK	74.0	-13.9	1.60 H	113	62.8	-2.7
2	2386.80	43.8 AV	54.0	-10.2	1.60 H	113	46.5	-2.7
3	2390.00	66.1 PK	74.0	-7.9	1.60 H	113	68.8	-2.7
4	2390.00	43.5 AV	54.0	-10.5	1.60 H	113	46.2	-2.7
5	*2412.00	113.7 PK			1.60 H	113	116.4	-2.7
6	*2412.00	102.0 AV			1.60 H	113	104.7	-2.7
7	4824.00	42.6 PK	74.0	-31.4	1.30 H	220	40.8	1.8
8	4824.00	31.2 AV	54.0	-22.8	1.30 H	220	29.4	1.8

Antenna Polarity & Test Distance : Vertical at 3 m

No	Frequency (MHz)	Emission Level (dBuV/m)	Limit (dBuV/m)	Margin (dB)	Antenna Height (m)	Table Angle (Degree)	Raw Value (dBuV)	Correction Factor (dB/m)
1	2387.70	70.8 PK	74.0	-3.2	1.59 V	159	73.5	-2.7
2	2387.70	46.3 AV	54.0	-7.7	1.59 V	159	49.0	-2.7
3	2388.26	72.5 PK	74.0	-1.5	1.59 V	159	75.2	-2.7
4	2388.26	46.0 AV	54.0	-8.0	1.59 V	159	48.7	-2.7
5	*2412.00	120.6 PK			1.59 V	159	123.3	-2.7
6	*2412.00	109.1 AV			1.59 V	159	111.8	-2.7
7	4824.00	46.3 PK	74.0	-27.7	1.57 V	70	44.5	1.8
8	4824.00	35.1 AV	54.0	-18.9	1.57 V	70	33.3	1.8

Remarks:

1. Emission Level(dBuV/m) = Raw Value(dBuV) + Correction Factor(dB/m)
2. Correction Factor(dB/m) = Antenna Factor(dB/m) + Cable Factor(dB) – Pre-Amplifier Factor(dB)
3. Margin value = Emission Level – Limit value
4. The other emission levels were very low against the limit.
5. " * ": Fundamental frequency.

RF Mode	TX 20MHz Preamble 802.11ax (RU26)	Channel	CH 6 : 2437 MHz
Frequency Range	1GHz ~ 25GHz	Detector Function	Peak (PK) Average (AV)

Antenna Polarity & Test Distance : Horizontal at 3 m

No	Frequency (MHz)	Emission Level (dBuV/m)	Limit (dBuV/m)	Margin (dB)	Antenna Height (m)	Table Angle (Degree)	Raw Value (dBuV)	Correction Factor (dB/m)
1	2390.00	54.9 PK	74.0	-19.1	1.56 H	105	57.6	-2.7
2	2390.00	41.8 AV	54.0	-12.2	1.56 H	105	44.5	-2.7
3	*2437.00	117.3 PK			1.56 H	105	120.0	-2.7
4	*2437.00	106.3 AV			1.56 H	105	109.0	-2.7
5	2483.50	56.2 PK	74.0	-17.8	1.56 H	105	59.0	-2.8
6	2483.50	42.5 AV	54.0	-11.5	1.56 H	105	45.3	-2.8
7	4874.00	42.9 PK	74.0	-31.1	1.37 H	223	41.2	1.7
8	4874.00	31.4 AV	54.0	-22.6	1.37 H	223	29.7	1.7
9	7311.00	62.5 PK	74.0	-11.5	1.06 H	274	55.3	7.2
10	7311.00	47.0 AV	54.0	-7.0	1.06 H	274	39.8	7.2

Antenna Polarity & Test Distance : Vertical at 3 m

No	Frequency (MHz)	Emission Level (dBuV/m)	Limit (dBuV/m)	Margin (dB)	Antenna Height (m)	Table Angle (Degree)	Raw Value (dBuV)	Correction Factor (dB/m)
1	2390.00	57.3 PK	74.0	-16.7	1.59 V	144	60.0	-2.7
2	2390.00	43.4 AV	54.0	-10.6	1.59 V	144	46.1	-2.7
3	*2437.00	123.5 PK			1.59 V	144	126.2	-2.7
4	*2437.00	114.7 AV			1.59 V	144	117.4	-2.7
5	2483.50	58.6 PK	74.0	-15.4	1.59 V	144	61.4	-2.8
6	2483.50	43.8 AV	54.0	-10.2	1.59 V	144	46.6	-2.8
7	4874.00	46.6 PK	74.0	-27.4	1.50 V	87	44.9	1.7
8	4874.00	35.5 AV	54.0	-18.5	1.50 V	87	33.8	1.7
9	7311.00	64.6 PK	74.0	-9.4	1.50 V	46	57.4	7.2
10	7311.00	50.5 AV	54.0	-3.5	1.50 V	46	43.3	7.2

Remarks:

1. Emission Level(dBuV/m) = Raw Value(dBuV) + Correction Factor(dB/m)
2. Correction Factor(dB/m) = Antenna Factor(dB/m) + Cable Factor(dB) – Pre-Amplifier Factor(dB)
3. Margin value = Emission Level – Limit value
4. The other emission levels were very low against the limit.
5. " * " : Fundamental frequency.

RF Mode	TX 20MHz Preamble 802.11ax (RU26)	Channel	CH 11 : 2462 MHz
Frequency Range	1GHz ~ 25GHz	Detector Function	Peak (PK) Average (AV)

Antenna Polarity & Test Distance : Horizontal at 3 m

No	Frequency (MHz)	Emission Level (dBuV/m)	Limit (dBuV/m)	Margin (dB)	Antenna Height (m)	Table Angle (Degree)	Raw Value (dBuV)	Correction Factor (dB/m)
1	*2462.00	112.1 PK			1.27 H	113	114.9	-2.8
2	*2462.00	101.0 AV			1.27 H	113	103.8	-2.8
3	2483.50	68.0 PK	74.0	-6.0	1.27 H	113	70.8	-2.8
4	2483.50	43.4 AV	54.0	-10.6	1.27 H	113	46.2	-2.8
5	4924.00	42.7 PK	74.0	-31.3	1.34 H	232	40.9	1.8
6	4924.00	31.2 AV	54.0	-22.8	1.34 H	232	29.4	1.8
7	7386.00	57.4 PK	74.0	-16.6	1.06 H	273	50.0	7.4
8	7386.00	42.2 AV	54.0	-11.8	1.06 H	273	34.8	7.4

Antenna Polarity & Test Distance : Vertical at 3 m

No	Frequency (MHz)	Emission Level (dBuV/m)	Limit (dBuV/m)	Margin (dB)	Antenna Height (m)	Table Angle (Degree)	Raw Value (dBuV)	Correction Factor (dB/m)
1	*2462.00	122.1 PK			1.60 V	245	124.9	-2.8
2	*2462.00	109.1 AV			1.60 V	245	111.9	-2.8
3	2483.82	72.4 PK	74.0	-1.6	1.60 V	245	75.2	-2.8
4	2483.82	45.3 AV	54.0	-8.7	1.60 V	245	48.1	-2.8
5	4924.00	46.5 PK	74.0	-27.5	1.53 V	78	44.7	1.8
6	4924.00	35.2 AV	54.0	-18.8	1.53 V	78	33.4	1.8
7	7386.00	64.2 PK	74.0	-9.8	1.49 V	61	56.8	7.4
8	7386.00	46.8 AV	54.0	-7.2	1.49 V	61	39.4	7.4

Remarks:

1. Emission Level(dBuV/m) = Raw Value(dBuV) + Correction Factor(dB/m)
2. Correction Factor(dB/m) = Antenna Factor(dB/m) + Cable Factor(dB) – Pre-Amplifier Factor(dB)
3. Margin value = Emission Level – Limit value
4. The other emission levels were very low against the limit.
5. " * ": Fundamental frequency.

RF Mode	TX 20MHz Preamble 802.11ax (RU26)	Channel	CH 12 : 2467 MHz
Frequency Range	1GHz ~ 25GHz	Detector Function	Peak (PK) Average (AV)

Antenna Polarity & Test Distance : Horizontal at 3 m

No	Frequency (MHz)	Emission Level (dBuV/m)	Limit (dBuV/m)	Margin (dB)	Antenna Height (m)	Table Angle (Degree)	Raw Value (dBuV)	Correction Factor (dB/m)
1	*2467.00	109.3 PK			1.35 H	110	112.1	-2.8
2	*2467.00	98.1 AV			1.35 H	110	100.9	-2.8
3	2484.90	71.3 PK	74.0	-2.7	1.35 H	110	74.1	-2.8
4	2484.90	43.4 AV	54.0	-10.6	1.35 H	110	46.2	-2.8
5	4934.00	42.0 PK	74.0	-32.0	1.29 H	243	40.2	1.8
6	4934.00	30.7 AV	54.0	-23.3	1.29 H	243	28.9	1.8
7	7401.00	56.8 PK	74.0	-17.2	1.04 H	286	49.3	7.5
8	7401.00	41.7 AV	54.0	-12.3	1.04 H	286	34.2	7.5

Antenna Polarity & Test Distance : Vertical at 3 m

No	Frequency (MHz)	Emission Level (dBuV/m)	Limit (dBuV/m)	Margin (dB)	Antenna Height (m)	Table Angle (Degree)	Raw Value (dBuV)	Correction Factor (dB/m)
1	*2467.00	119.2 PK			1.64 V	250	122.0	-2.8
2	*2467.00	106.3 AV			1.64 V	250	109.1	-2.8
3	2485.08	72.4 PK	74.0	-1.6	1.64 V	250	75.2	-2.8
4	2485.08	45.1 AV	54.0	-8.9	1.64 V	250	47.9	-2.8
5	4934.00	46.1 PK	74.0	-27.9	1.52 V	62	44.3	1.8
6	4934.00	35.0 AV	54.0	-19.0	1.52 V	62	33.2	1.8
7	7401.00	64.3 PK	74.0	-9.7	1.50 V	48	56.8	7.5
8	7401.00	47.1 AV	54.0	-6.9	1.50 V	48	39.6	7.5

Remarks:

1. Emission Level(dBuV/m) = Raw Value(dBuV) + Correction Factor(dB/m)
2. Correction Factor(dB/m) = Antenna Factor(dB/m) + Cable Factor(dB) – Pre-Amplifier Factor(dB)
3. Margin value = Emission Level – Limit value
4. The other emission levels were very low against the limit.
5. " * ": Fundamental frequency.

RF Mode	TX 20MHz Preamble 802.11ax (RU26)	Channel	CH 13 : 2472 MHz
Frequency Range	1GHz ~ 25GHz	Detector Function	Peak (PK) Average (AV)

Antenna Polarity & Test Distance : Horizontal at 3 m

No	Frequency (MHz)	Emission Level (dBuV/m)	Limit (dBuV/m)	Margin (dB)	Antenna Height (m)	Table Angle (Degree)	Raw Value (dBuV)	Correction Factor (dB/m)
1	*2472.00	106.1 PK			1.43 H	115	108.9	-2.8
2	*2472.00	93.4 AV			1.43 H	115	96.2	-2.8
3	2483.50	65.9 PK	74.0	-8.1	1.43 H	115	68.7	-2.8
4	2483.50	44.6 AV	54.0	-9.4	1.43 H	115	47.4	-2.8
5	4944.00	42.4 PK	74.0	-31.6	1.40 H	238	40.6	1.8
6	4944.00	31.0 AV	54.0	-23.0	1.40 H	238	29.2	1.8
7	7416.00	57.1 PK	74.0	-16.9	1.01 H	282	49.6	7.5
8	7416.00	41.8 AV	54.0	-12.2	1.01 H	282	34.3	7.5

Antenna Polarity & Test Distance : Vertical at 3 m

No	Frequency (MHz)	Emission Level (dBuV/m)	Limit (dBuV/m)	Margin (dB)	Antenna Height (m)	Table Angle (Degree)	Raw Value (dBuV)	Correction Factor (dB/m)
1	*2472.00	113.9 PK			1.57 V	311	116.7	-2.8
2	*2472.00	101.2 AV			1.57 V	311	104.0	-2.8
3	2483.50	72.5 PK	74.0	-1.5	1.57 V	311	75.3	-2.8
4	2483.50	47.9 AV	54.0	-6.1	1.57 V	311	50.7	-2.8
5	4944.00	47.0 PK	74.0	-27.0	1.51 V	86	45.2	1.8
6	4944.00	35.7 AV	54.0	-18.3	1.51 V	86	33.9	1.8
7	7416.00	64.1 PK	74.0	-9.9	1.53 V	75	56.6	7.5
8	7416.00	46.7 AV	54.0	-7.3	1.53 V	75	39.2	7.5

Remarks:

1. Emission Level(dBuV/m) = Raw Value(dBuV) + Correction Factor(dB/m)
2. Correction Factor(dB/m) = Antenna Factor(dB/m) + Cable Factor(dB) – Pre-Amplifier Factor(dB)
3. Margin value = Emission Level – Limit value
4. The other emission levels were very low against the limit.
5. " * ": Fundamental frequency.

RF Mode	TX 20MHz Preamble 802.11ax (RU52)	Channel	CH 1 : 2412 MHz
Frequency Range	1GHz ~ 25GHz	Detector Function	Peak (PK) Average (AV)

Antenna Polarity & Test Distance : Horizontal at 3 m

No	Frequency (MHz)	Emission Level (dBuV/m)	Limit (dBuV/m)	Margin (dB)	Antenna Height (m)	Table Angle (Degree)	Raw Value (dBuV)	Correction Factor (dB/m)
1	2388.22	66.5 PK	74.0	-7.5	1.58 H	116	69.2	-2.7
2	2388.22	44.6 AV	54.0	-9.4	1.58 H	116	47.3	-2.7
3	2390.00	63.7 PK	74.0	-10.3	1.58 H	116	66.4	-2.7
4	2390.00	45.2 AV	54.0	-8.8	1.58 H	116	47.9	-2.7
5	*2412.00	113.0 PK			1.58 H	116	115.7	-2.7
6	*2412.00	101.9 AV			1.58 H	116	104.6	-2.7
7	4824.00	42.7 PK	74.0	-31.3	1.34 H	247	40.9	1.8
8	4824.00	31.1 AV	54.0	-22.9	1.34 H	247	29.3	1.8

Antenna Polarity & Test Distance : Vertical at 3 m

No	Frequency (MHz)	Emission Level (dBuV/m)	Limit (dBuV/m)	Margin (dB)	Antenna Height (m)	Table Angle (Degree)	Raw Value (dBuV)	Correction Factor (dB/m)
1	2388.17	72.5 PK	74.0	-1.5	1.56 V	164	75.2	-2.7
2	2388.17	47.6 AV	54.0	-6.4	1.56 V	164	50.3	-2.7
3	2390.00	70.8 PK	74.0	-3.2	1.56 V	164	73.5	-2.7
4	2390.00	48.3 AV	54.0	-5.7	1.56 V	164	51.0	-2.7
5	*2412.00	120.8 PK			1.56 V	164	123.5	-2.7
6	*2412.00	109.1 AV			1.56 V	164	111.8	-2.7
7	4824.00	46.6 PK	74.0	-27.4	1.57 V	85	44.8	1.8
8	4824.00	35.4 AV	54.0	-18.6	1.57 V	85	33.6	1.8

Remarks:

1. Emission Level(dBuV/m) = Raw Value(dBuV) + Correction Factor(dB/m)
2. Correction Factor(dB/m) = Antenna Factor(dB/m) + Cable Factor(dB) – Pre-Amplifier Factor(dB)
3. Margin value = Emission Level – Limit value
4. The other emission levels were very low against the limit.
5. " * ": Fundamental frequency.

RF Mode	TX 20MHz Preamble 802.11ax (RU52)	Channel	CH 6 : 2437 MHz
Frequency Range	1GHz ~ 25GHz	Detector Function	Peak (PK) Average (AV)

Antenna Polarity & Test Distance : Horizontal at 3 m

No	Frequency (MHz)	Emission Level (dBuV/m)	Limit (dBuV/m)	Margin (dB)	Antenna Height (m)	Table Angle (Degree)	Raw Value (dBuV)	Correction Factor (dB/m)
1	2390.00	55.6 PK	74.0	-18.4	1.62 H	101	58.3	-2.7
2	2390.00	42.3 AV	54.0	-11.7	1.62 H	101	45.0	-2.7
3	*2437.00	115.3 PK			1.62 H	101	118.0	-2.7
4	*2437.00	104.1 AV			1.62 H	101	106.8	-2.7
5	2483.50	55.8 PK	74.0	-18.2	1.62 H	101	58.6	-2.8
6	2483.50	42.3 AV	54.0	-11.7	1.62 H	101	45.1	-2.8
7	4874.00	43.4 PK	74.0	-30.6	1.36 H	226	41.7	1.7
8	4874.00	31.7 AV	54.0	-22.3	1.36 H	226	30.0	1.7
9	7311.00	57.8 PK	74.0	-16.2	1.08 H	258	50.6	7.2
10	7311.00	42.5 AV	54.0	-11.5	1.08 H	258	35.3	7.2

Antenna Polarity & Test Distance : Vertical at 3 m

No	Frequency (MHz)	Emission Level (dBuV/m)	Limit (dBuV/m)	Margin (dB)	Antenna Height (m)	Table Angle (Degree)	Raw Value (dBuV)	Correction Factor (dB/m)
1	2390.00	57.9 PK	74.0	-16.1	1.54 V	172	60.6	-2.7
2	2390.00	43.7 AV	54.0	-10.3	1.54 V	172	46.4	-2.7
3	*2437.00	121.7 PK			1.54 V	172	124.4	-2.7
4	*2437.00	111.8 AV			1.54 V	172	114.5	-2.7
5	2483.50	60.8 PK	74.0	-13.2	1.54 V	172	63.6	-2.8
6	2483.50	44.6 AV	54.0	-9.4	1.54 V	172	47.4	-2.8
7	4874.00	46.7 PK	74.0	-27.3	1.56 V	69	45.0	1.7
8	4874.00	35.6 AV	54.0	-18.4	1.56 V	69	33.9	1.7
9	7311.00	61.8 PK	74.0	-12.2	1.44 V	59	54.6	7.2
10	7311.00	48.1 AV	54.0	-5.9	1.44 V	59	40.9	7.2

Remarks:

1. Emission Level(dBuV/m) = Raw Value(dBuV) + Correction Factor(dB/m)
2. Correction Factor(dB/m) = Antenna Factor(dB/m) + Cable Factor(dB) – Pre-Amplifier Factor(dB)
3. Margin value = Emission Level – Limit value
4. The other emission levels were very low against the limit.
5. " * ": Fundamental frequency.

RF Mode	TX 20MHz Preamble 802.11ax (RU52)	Channel	CH 11 : 2462 MHz
Frequency Range	1GHz ~ 25GHz	Detector Function	Peak (PK) Average (AV)

Antenna Polarity & Test Distance : Horizontal at 3 m

No	Frequency (MHz)	Emission Level (dBuV/m)	Limit (dBuV/m)	Margin (dB)	Antenna Height (m)	Table Angle (Degree)	Raw Value (dBuV)	Correction Factor (dB/m)
1	*2462.00	110.9 PK			1.30 H	110	113.7	-2.8
2	*2462.00	100.4 AV			1.30 H	110	103.2	-2.8
3	2483.50	66.5 PK	74.0	-7.5	1.30 H	110	69.3	-2.8
4	2483.50	43.9 AV	54.0	-10.1	1.30 H	110	46.7	-2.8
5	4924.00	42.5 PK	74.0	-31.5	1.30 H	234	40.7	1.8
6	4924.00	31.1 AV	54.0	-22.9	1.30 H	234	29.3	1.8
7	7386.00	57.3 PK	74.0	-16.7	1.01 H	261	49.9	7.4
8	7386.00	42.3 AV	54.0	-11.7	1.01 H	261	34.9	7.4

Antenna Polarity & Test Distance : Vertical at 3 m

No	Frequency (MHz)	Emission Level (dBuV/m)	Limit (dBuV/m)	Margin (dB)	Antenna Height (m)	Table Angle (Degree)	Raw Value (dBuV)	Correction Factor (dB/m)
1	*2462.00	120.3 PK			1.63 V	235	123.1	-2.8
2	*2462.00	108.9 AV			1.63 V	235	111.7	-2.8
3	2483.50	72.2 PK	74.0	-1.8	1.63 V	235	75.0	-2.8
4	2483.50	47.1 AV	54.0	-6.9	1.63 V	235	49.9	-2.8
5	4924.00	46.1 PK	74.0	-27.9	1.57 V	93	44.3	1.8
6	4924.00	34.7 AV	54.0	-19.3	1.57 V	93	32.9	1.8
7	7386.00	64.6 PK	74.0	-9.4	1.52 V	59	57.2	7.4
8	7386.00	47.3 AV	54.0	-6.7	1.52 V	59	39.9	7.4

Remarks:

1. Emission Level(dBuV/m) = Raw Value(dBuV) + Correction Factor(dB/m)
2. Correction Factor(dB/m) = Antenna Factor(dB/m) + Cable Factor(dB) – Pre-Amplifier Factor(dB)
3. Margin value = Emission Level – Limit value
4. The other emission levels were very low against the limit.
5. " * ": Fundamental frequency.

RF Mode	TX 20MHz Preamble 802.11ax (RU52)	Channel	CH 12 : 2467 MHz
Frequency Range	1GHz ~ 25GHz	Detector Function	Peak (PK) Average (AV)

Antenna Polarity & Test Distance : Horizontal at 3 m

No	Frequency (MHz)	Emission Level (dBuV/m)	Limit (dBuV/m)	Margin (dB)	Antenna Height (m)	Table Angle (Degree)	Raw Value (dBuV)	Correction Factor (dB/m)
1	*2467.00	109.6 PK			1.30 H	111	112.4	-2.8
2	*2467.00	99.2 AV			1.30 H	111	102.0	-2.8
3	2483.95	70.7 PK	74.0	-3.3	1.30 H	111	73.5	-2.8
4	2483.95	44.7 AV	54.0	-9.3	1.30 H	111	47.5	-2.8
5	4934.00	42.9 PK	74.0	-31.1	1.34 H	243	41.1	1.8
6	4934.00	31.3 AV	54.0	-22.7	1.34 H	243	29.5	1.8
7	7401.00	57.5 PK	74.0	-16.5	1.05 H	271	50.0	7.5
8	7401.00	42.3 AV	54.0	-11.7	1.05 H	271	34.8	7.5

Antenna Polarity & Test Distance : Vertical at 3 m

No	Frequency (MHz)	Emission Level (dBuV/m)	Limit (dBuV/m)	Margin (dB)	Antenna Height (m)	Table Angle (Degree)	Raw Value (dBuV)	Correction Factor (dB/m)
1	*2467.00	119.9 PK			1.65 V	240	122.7	-2.8
2	*2467.00	108.3 AV			1.65 V	240	111.1	-2.8
3	2484.74	72.5 PK	74.0	-1.5	1.65 V	240	75.3	-2.8
4	2484.74	48.1 AV	54.0	-5.9	1.65 V	240	50.9	-2.8
5	4934.00	47.0 PK	74.0	-27.0	1.58 V	69	45.2	1.8
6	4934.00	35.6 AV	54.0	-18.4	1.58 V	69	33.8	1.8
7	7401.00	64.1 PK	74.0	-9.9	1.52 V	68	56.6	7.5
8	7401.00	46.6 AV	54.0	-7.4	1.52 V	68	39.1	7.5

Remarks:

1. Emission Level(dBuV/m) = Raw Value(dBuV) + Correction Factor(dB/m)
2. Correction Factor(dB/m) = Antenna Factor(dB/m) + Cable Factor(dB) – Pre-Amplifier Factor(dB)
3. Margin value = Emission Level – Limit value
4. The other emission levels were very low against the limit.
5. " * ": Fundamental frequency.

RF Mode	TX 20MHz Preamble 802.11ax (RU52)	Channel	CH 13 : 2472 MHz
Frequency Range	1GHz ~ 25GHz	Detector Function	Peak (PK) Average (AV)

Antenna Polarity & Test Distance : Horizontal at 3 m

No	Frequency (MHz)	Emission Level (dBuV/m)	Limit (dBuV/m)	Margin (dB)	Antenna Height (m)	Table Angle (Degree)	Raw Value (dBuV)	Correction Factor (dB/m)
1	*2472.00	99.5 PK			1.31 H	105	102.3	-2.8
2	*2472.00	88.5 AV			1.31 H	105	91.3	-2.8
3	2483.50	63.0 PK	74.0	-11.0	1.31 H	105	65.8	-2.8
4	2483.50	43.5 AV	54.0	-10.5	1.31 H	105	46.3	-2.8
5	4944.00	42.6 PK	74.0	-31.4	1.29 H	225	40.8	1.8
6	4944.00	31.2 AV	54.0	-22.8	1.29 H	225	29.4	1.8
7	7416.00	57.2 PK	74.0	-16.8	1.11 H	274	49.7	7.5
8	7416.00	42.0 AV	54.0	-12.0	1.11 H	274	34.5	7.5

Antenna Polarity & Test Distance : Vertical at 3 m

No	Frequency (MHz)	Emission Level (dBuV/m)	Limit (dBuV/m)	Margin (dB)	Antenna Height (m)	Table Angle (Degree)	Raw Value (dBuV)	Correction Factor (dB/m)
1	*2472.00	112.0 PK			1.61 V	312	114.8	-2.8
2	*2472.00	100.4 AV			1.61 V	312	103.2	-2.8
3	2483.50	72.5 PK	74.0	-1.5	1.61 V	312	75.3	-2.8
4	2483.50	47.8 AV	54.0	-6.2	1.61 V	312	50.6	-2.8
5	4944.00	46.7 PK	74.0	-27.3	1.56 V	66	44.9	1.8
6	4944.00	35.3 AV	54.0	-18.7	1.56 V	66	33.5	1.8
7	7416.00	64.1 PK	74.0	-9.9	1.53 V	57	56.6	7.5
8	7416.00	46.6 AV	54.0	-7.4	1.53 V	57	39.1	7.5

Remarks:

1. Emission Level(dBuV/m) = Raw Value(dBuV) + Correction Factor(dB/m)
2. Correction Factor(dB/m) = Antenna Factor(dB/m) + Cable Factor(dB) – Pre-Amplifier Factor(dB)
3. Margin value = Emission Level – Limit value
4. The other emission levels were very low against the limit.
5. " * ": Fundamental frequency.

RF Mode	TX 20MHz Preamble 802.11ax (RU106)	Channel	CH 1 : 2412 MHz
Frequency Range	1GHz ~ 25GHz	Detector Function	Peak (PK) Average (AV)

Antenna Polarity & Test Distance : Horizontal at 3 m

No	Frequency (MHz)	Emission Level (dBuV/m)	Limit (dBuV/m)	Margin (dB)	Antenna Height (m)	Table Angle (Degree)	Raw Value (dBuV)	Correction Factor (dB/m)
1	2388.68	61.8 PK	74.0	-12.2	1.54 H	109	64.5	-2.7
2	2388.68	44.4 AV	54.0	-9.6	1.54 H	109	47.1	-2.7
3	2390.00	60.1 PK	74.0	-13.9	1.54 H	109	62.8	-2.7
4	2390.00	44.7 AV	54.0	-9.3	1.54 H	109	47.4	-2.7
5	*2412.00	110.2 PK			1.54 H	109	112.9	-2.7
6	*2412.00	98.8 AV			1.54 H	109	101.5	-2.7
7	4824.00	42.9 PK	74.0	-31.1	1.29 H	224	41.1	1.8
8	4824.00	31.3 AV	54.0	-22.7	1.29 H	224	29.5	1.8

Antenna Polarity & Test Distance : Vertical at 3 m

No	Frequency (MHz)	Emission Level (dBuV/m)	Limit (dBuV/m)	Margin (dB)	Antenna Height (m)	Table Angle (Degree)	Raw Value (dBuV)	Correction Factor (dB/m)
1	2388.44	67.6 PK	74.0	-6.4	1.57 V	159	70.3	-2.7
2	2388.44	47.3 AV	54.0	-6.7	1.57 V	159	50.0	-2.7
3	2390.00	66.6 PK	74.0	-7.4	1.57 V	159	69.3	-2.7
4	2390.00	47.8 AV	54.0	-6.2	1.57 V	159	50.5	-2.7
5	*2412.00	117.8 PK			1.57 V	159	120.5	-2.7
6	*2412.00	106.5 AV			1.57 V	159	109.2	-2.7
7	4824.00	46.5 PK	74.0	-27.5	1.50 V	86	44.7	1.8
8	4824.00	34.9 AV	54.0	-19.1	1.50 V	86	33.1	1.8

Remarks:

1. Emission Level(dBuV/m) = Raw Value(dBuV) + Correction Factor(dB/m)
2. Correction Factor(dB/m) = Antenna Factor(dB/m) + Cable Factor(dB) – Pre-Amplifier Factor(dB)
3. Margin value = Emission Level – Limit value
4. The other emission levels were very low against the limit.
5. " * ": Fundamental frequency.

RF Mode	TX 20MHz Preamble 802.11ax (RU106)	Channel	CH 6 : 2437 MHz
Frequency Range	1GHz ~ 25GHz	Detector Function	Peak (PK) Average (AV)

Antenna Polarity & Test Distance : Horizontal at 3 m

No	Frequency (MHz)	Emission Level (dBuV/m)	Limit (dBuV/m)	Margin (dB)	Antenna Height (m)	Table Angle (Degree)	Raw Value (dBuV)	Correction Factor (dB/m)
1	2390.00	54.4 PK	74.0	-19.6	1.49 H	99	57.1	-2.7
2	2390.00	41.6 AV	54.0	-12.4	1.49 H	99	44.3	-2.7
3	*2437.00	113.1 PK			1.49 H	99	115.8	-2.7
4	*2437.00	103.4 AV			1.49 H	99	106.1	-2.7
5	2483.50	56.3 PK	74.0	-17.7	1.49 H	99	59.1	-2.8
6	2483.50	42.5 AV	54.0	-11.5	1.49 H	99	45.3	-2.8
7	4874.00	42.8 PK	74.0	-31.2	1.37 H	230	41.1	1.7
8	4874.00	31.4 AV	54.0	-22.6	1.37 H	230	29.7	1.7
9	7311.00	57.5 PK	74.0	-16.5	1.11 H	264	50.3	7.2
10	7311.00	42.0 AV	54.0	-12.0	1.11 H	264	34.8	7.2

Antenna Polarity & Test Distance : Vertical at 3 m

No	Frequency (MHz)	Emission Level (dBuV/m)	Limit (dBuV/m)	Margin (dB)	Antenna Height (m)	Table Angle (Degree)	Raw Value (dBuV)	Correction Factor (dB/m)
1	2390.00	61.8 PK	74.0	-12.2	1.57 V	148	64.5	-2.7
2	2390.00	44.5 AV	54.0	-9.5	1.57 V	148	47.2	-2.7
3	*2437.00	120.9 PK			1.57 V	148	123.6	-2.7
4	*2437.00	110.6 AV			1.57 V	148	113.3	-2.7
5	2483.50	71.3 PK	74.0	-2.7	1.57 V	148	74.1	-2.8
6	2483.50	46.5 AV	54.0	-7.5	1.57 V	148	49.3	-2.8
7	4874.00	46.0 PK	74.0	-28.0	1.57 V	84	44.3	1.7
8	4874.00	34.8 AV	54.0	-19.2	1.57 V	84	33.1	1.7
9	7311.00	64.2 PK	74.0	-9.8	1.53 V	47	57.0	7.2
10	7311.00	46.9 AV	54.0	-7.1	1.53 V	47	39.7	7.2

Remarks:

1. Emission Level(dBuV/m) = Raw Value(dBuV) + Correction Factor(dB/m)
2. Correction Factor(dB/m) = Antenna Factor(dB/m) + Cable Factor(dB) – Pre-Amplifier Factor(dB)
3. Margin value = Emission Level – Limit value
4. The other emission levels were very low against the limit.
5. " * ": Fundamental frequency.

RF Mode	TX 20MHz Preamble 802.11ax (RU106)	Channel	CH 11 : 2462 MHz
Frequency Range	1GHz ~ 25GHz	Detector Function	Peak (PK) Average (AV)

Antenna Polarity & Test Distance : Horizontal at 3 m

No	Frequency (MHz)	Emission Level (dBuV/m)	Limit (dBuV/m)	Margin (dB)	Antenna Height (m)	Table Angle (Degree)	Raw Value (dBuV)	Correction Factor (dB/m)
1	*2462.00	108.5 PK			1.16 H	107	111.3	-2.8
2	*2462.00	97.9 AV			1.16 H	107	100.7	-2.8
3	2484.23	62.6 PK	74.0	-11.4	1.16 H	107	65.4	-2.8
4	2484.23	44.9 AV	54.0	-9.1	1.16 H	107	47.7	-2.8
5	4924.00	42.4 PK	74.0	-31.6	1.35 H	238	40.6	1.8
6	4924.00	31.0 AV	54.0	-23.0	1.35 H	238	29.2	1.8
7	7386.00	57.5 PK	74.0	-16.5	1.07 H	265	50.1	7.4
8	7386.00	42.3 AV	54.0	-11.7	1.07 H	265	34.9	7.4

Antenna Polarity & Test Distance : Vertical at 3 m

No	Frequency (MHz)	Emission Level (dBuV/m)	Limit (dBuV/m)	Margin (dB)	Antenna Height (m)	Table Angle (Degree)	Raw Value (dBuV)	Correction Factor (dB/m)
1	*2462.00	117.1 PK			1.63 V	232	119.9	-2.8
2	*2462.00	106.1 AV			1.63 V	232	108.9	-2.8
3	2483.85	72.5 PK	74.0	-1.5	1.63 V	232	75.3	-2.8
4	2483.85	48.0 AV	54.0	-6.0	1.63 V	232	50.8	-2.8
5	4924.00	46.4 PK	74.0	-27.6	1.50 V	91	44.6	1.8
6	4924.00	35.3 AV	54.0	-18.7	1.50 V	91	33.5	1.8
7	7386.00	63.6 PK	74.0	-10.4	1.52 V	63	56.2	7.4
8	7386.00	46.4 AV	54.0	-7.6	1.52 V	63	39.0	7.4

Remarks:

1. Emission Level(dBuV/m) = Raw Value(dBuV) + Correction Factor(dB/m)
2. Correction Factor(dB/m) = Antenna Factor(dB/m) + Cable Factor(dB) – Pre-Amplifier Factor(dB)
3. Margin value = Emission Level – Limit value
4. The other emission levels were very low against the limit.
5. " * ": Fundamental frequency.

RF Mode	TX 20MHz Preamble 802.11ax (RU106)	Channel	CH 12 : 2467 MHz
Frequency Range	1GHz ~ 25GHz	Detector Function	Peak (PK) Average (AV)

Antenna Polarity & Test Distance : Horizontal at 3 m

No	Frequency (MHz)	Emission Level (dBuV/m)	Limit (dBuV/m)	Margin (dB)	Antenna Height (m)	Table Angle (Degree)	Raw Value (dBuV)	Correction Factor (dB/m)
1	*2467.00	106.3 PK			1.20 H	109	109.1	-2.8
2	*2467.00	95.3 AV			1.20 H	109	98.1	-2.8
3	2483.50	65.2 PK	74.0	-8.8	1.20 H	109	68.0	-2.8
4	2483.50	45.5 AV	54.0	-8.5	1.20 H	109	48.3	-2.8
5	4934.00	42.1 PK	74.0	-31.9	1.30 H	246	40.3	1.8
6	4934.00	30.7 AV	54.0	-23.3	1.30 H	246	28.9	1.8
7	7401.00	57.4 PK	74.0	-16.6	1.07 H	274	49.9	7.5
8	7401.00	42.1 AV	54.0	-11.9	1.07 H	274	34.6	7.5

Antenna Polarity & Test Distance : Vertical at 3 m

No	Frequency (MHz)	Emission Level (dBuV/m)	Limit (dBuV/m)	Margin (dB)	Antenna Height (m)	Table Angle (Degree)	Raw Value (dBuV)	Correction Factor (dB/m)
1	*2467.00	115.5 PK			1.60 V	237	118.3	-2.8
2	*2467.00	104.4 AV			1.60 V	237	107.2	-2.8
3	2483.50	72.5 PK	74.0	-1.5	1.60 V	237	75.3	-2.8
4	2483.50	47.7 AV	54.0	-6.3	1.60 V	237	50.5	-2.8
5	4934.00	46.9 PK	74.0	-27.1	1.57 V	78	45.1	1.8
6	4934.00	35.6 AV	54.0	-18.4	1.57 V	78	33.8	1.8
7	7401.00	64.7 PK	74.0	-9.3	1.43 V	62	57.2	7.5
8	7401.00	47.2 AV	54.0	-6.8	1.43 V	62	39.7	7.5

Remarks:

1. Emission Level(dBuV/m) = Raw Value(dBuV) + Correction Factor(dB/m)
2. Correction Factor(dB/m) = Antenna Factor(dB/m) + Cable Factor(dB) – Pre-Amplifier Factor(dB)
3. Margin value = Emission Level – Limit value
4. The other emission levels were very low against the limit.
5. " * ": Fundamental frequency.

RF Mode	TX 20MHz Preamble 802.11ax (RU106)	Channel	CH 13 : 2472 MHz
Frequency Range	1GHz ~ 25GHz	Detector Function	Peak (PK) Average (AV)

Antenna Polarity & Test Distance : Horizontal at 3 m

No	Frequency (MHz)	Emission Level (dBuV/m)	Limit (dBuV/m)	Margin (dB)	Antenna Height (m)	Table Angle (Degree)	Raw Value (dBuV)	Correction Factor (dB/m)
1	*2472.00	104.4 PK			1.23 H	106	107.2	-2.8
2	*2472.00	93.4 AV			1.23 H	106	96.2	-2.8
3	2483.50	69.7 PK	74.0	-4.3	1.23 H	106	72.5	-2.8
4	2483.50	46.3 AV	54.0	-7.7	1.23 H	106	49.1	-2.8
5	4944.00	42.3 PK	74.0	-31.7	1.36 H	219	40.5	1.8
6	4944.00	30.9 AV	54.0	-23.1	1.36 H	219	29.1	1.8
7	7416.00	57.6 PK	74.0	-16.4	1.10 H	286	50.1	7.5
8	7416.00	42.3 AV	54.0	-11.7	1.10 H	286	34.8	7.5

Antenna Polarity & Test Distance : Vertical at 3 m

No	Frequency (MHz)	Emission Level (dBuV/m)	Limit (dBuV/m)	Margin (dB)	Antenna Height (m)	Table Angle (Degree)	Raw Value (dBuV)	Correction Factor (dB/m)
1	*2472.00	113.0 PK			1.62 V	241	115.8	-2.8
2	*2472.00	101.9 AV			1.62 V	241	104.7	-2.8
3	2483.50	72.4 PK	74.0	-1.6	1.62 V	241	75.2	-2.8
4	2483.50	48.0 AV	54.0	-6.0	1.62 V	241	50.8	-2.8
5	4944.00	46.7 PK	74.0	-27.3	1.57 V	93	44.9	1.8
6	4944.00	35.6 AV	54.0	-18.4	1.57 V	93	33.8	1.8
7	7416.00	64.5 PK	74.0	-9.5	1.51 V	65	57.0	7.5
8	7416.00	47.2 AV	54.0	-6.8	1.51 V	65	39.7	7.5

Remarks:

1. Emission Level(dBuV/m) = Raw Value(dBuV) + Correction Factor(dB/m)
2. Correction Factor(dB/m) = Antenna Factor(dB/m) + Cable Factor(dB) – Pre-Amplifier Factor(dB)
3. Margin value = Emission Level – Limit value
4. The other emission levels were very low against the limit.
5. " * ": Fundamental frequency.

Below 1GHz Data:

RF Mode	TX 802.11g	Channel	CH 6 : 2437 MHz
Frequency Range	9kHz ~ 1GHz	Detector Function	Quasi-Peak (QP)

Antenna Polarity & Test Distance : Horizontal at 3 m								
No	Frequency (MHz)	Emission Level (dBuV/m)	Limit (dBuV/m)	Margin (dB)	Antenna Height (m)	Table Angle (Degree)	Raw Value (dBuV)	Correction Factor (dB/m)
1	119.26	37.7 QP	43.5	-5.8	3.00 H	342	52.8	-15.1
2	166.85	35.2 QP	43.5	-8.3	2.00 H	161	48.2	-13.0
3	227.60	34.3 QP	46.0	-11.7	2.00 H	119	50.1	-15.8
4	298.85	34.6 QP	46.0	-11.4	1.50 H	78	46.9	-12.3
5	336.33	33.4 QP	46.0	-12.6	1.50 H	348	44.7	-11.3
6	574.61	26.4 QP	46.0	-19.6	1.50 H	112	32.6	-6.2

Remarks:

1. Emission Level(dBuV/m) = Raw Value(dBuV) + Correction Factor(dB/m)
2. Correction Factor(dB/m) = Antenna Factor(dB/m) + Cable Factor(dB) – Pre-Amplifier Factor(dB)
3. Margin value = Emission Level – Limit value
4. The other emission levels were very low against the limit of frequency range 30MHz~1000MHz.
5. The emission levels were very low against the limit of frequency range 9kHz~30MHz: the amplitude of spurious emissions attenuated more than 20 dB below the permissible value to be report.

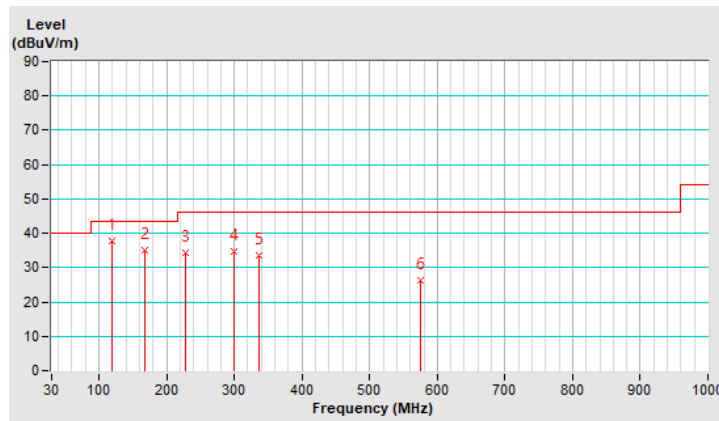

RF Mode	TX 802.11g	Channel	CH 6 : 2437 MHz
Frequency Range	9kHz ~ 1GHz	Detector Function	Quasi-Peak (QP)

Antenna Polarity & Test Distance : Vertical at 3 m								
No	Frequency (MHz)	Emission Level (dBuV/m)	Limit (dBuV/m)	Margin (dB)	Antenna Height (m)	Table Angle (Degree)	Raw Value (dBuV)	Correction Factor (dB/m)
1	126.74	29.7 QP	43.5	-13.8	1.00 V	49	44.1	-14.4
2	166.99	31.9 QP	43.5	-11.6	1.50 V	235	44.9	-13.0
3	222.85	30.8 QP	46.0	-15.2	1.00 V	144	46.8	-16.0
4	340.46	26.2 QP	46.0	-19.8	1.50 V	184	37.5	-11.3
5	498.42	24.2 QP	46.0	-21.8	1.50 V	56	31.9	-7.7
6	950.05	32.5 QP	46.0	-13.5	1.00 V	134	33.1	-0.6

Remarks:

1. Emission Level(dBuV/m) = Raw Value(dBuV) + Correction Factor(dB/m)
2. Correction Factor(dB/m) = Antenna Factor(dB/m) + Cable Factor(dB) – Pre-Amplifier Factor(dB)
3. Margin value = Emission Level – Limit value
4. The other emission levels were very low against the limit of frequency range 30MHz~1000MHz.
5. The emission levels were very low against the limit of frequency range 9kHz~30MHz: the amplitude of spurious emissions attenuated more than 20 dB below the permissible value to be report.

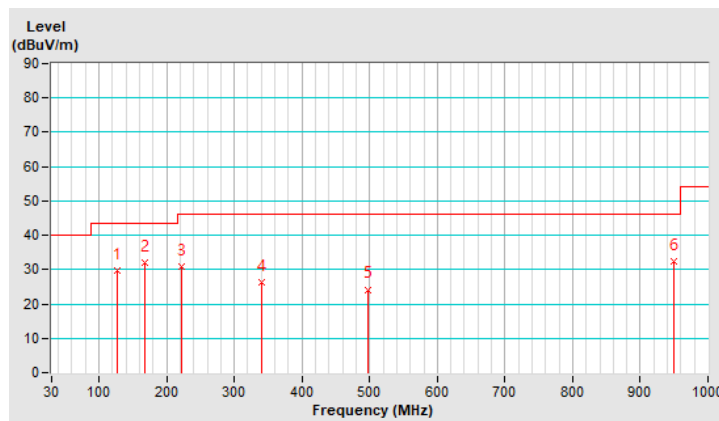

PIFA Antenna

Above 1GHz Data :

RF Mode	TX 802.11b	Channel	CH 1 : 2412 MHz
Frequency Range	1GHz ~ 25GHz	Detector Function	Peak (PK) Average (AV)

Antenna Polarity & Test Distance : Horizontal at 3 m

No	Frequency (MHz)	Emission Level (dBuV/m)	Limit (dBuV/m)	Margin (dB)	Antenna Height (m)	Table Angle (Degree)	Raw Value (dBuV)	Correction Factor (dB/m)
1	2386.40	59.5 PK	74.0	-14.5	1.16 H	314	62.2	-2.7
2	2386.40	52.3 AV	54.0	-1.7	1.16 H	314	55.0	-2.7
3	*2412.00	109.1 PK			1.16 H	314	111.8	-2.7
4	*2412.00	106.4 AV			1.16 H	314	109.1	-2.7
5	4824.00	42.7 PK	74.0	-31.3	1.41 H	145	40.9	1.8
6	4824.00	37.8 AV	54.0	-16.2	1.41 H	145	36.0	1.8

Antenna Polarity & Test Distance : Vertical at 3 m

No	Frequency (MHz)	Emission Level (dBuV/m)	Limit (dBuV/m)	Margin (dB)	Antenna Height (m)	Table Angle (Degree)	Raw Value (dBuV)	Correction Factor (dB/m)
1	2390.00	59.2 PK	74.0	-14.8	2.34 V	95	61.9	-2.7
2	2390.00	51.5 AV	54.0	-2.5	2.34 V	95	54.2	-2.7
3	*2412.00	107.2 PK			2.34 V	95	109.9	-2.7
4	*2412.00	104.2 AV			2.34 V	95	106.9	-2.7
5	4824.00	40.6 PK	74.0	-33.4	1.52 V	132	38.8	1.8
6	4824.00	33.4 AV	54.0	-20.6	1.52 V	132	31.6	1.8

Remarks:

1. Emission Level(dBuV/m) = Raw Value(dBuV) + Correction Factor(dB/m)
2. Correction Factor(dB/m) = Antenna Factor(dB/m) + Cable Factor(dB) – Pre-Amplifier Factor(dB)
3. Margin value = Emission Level – Limit value
4. The other emission levels were very low against the limit.
5. " * ": Fundamental frequency.

RF Mode	TX 802.11b	Channel	CH 6 : 2437 MHz
Frequency Range	1GHz ~ 25GHz	Detector Function	Peak (PK) Average (AV)

Antenna Polarity & Test Distance : Horizontal at 3 m

No	Frequency (MHz)	Emission Level (dBuV/m)	Limit (dBuV/m)	Margin (dB)	Antenna Height (m)	Table Angle (Degree)	Raw Value (dBuV)	Correction Factor (dB/m)
1	2390.00	61.8 PK	74.0	-12.2	1.16 H	322	64.5	-2.7
2	2390.00	45.1 AV	54.0	-8.9	1.16 H	322	47.8	-2.7
3	*2437.00	108.0 PK			1.16 H	322	110.7	-2.7
4	*2437.00	105.6 AV			1.16 H	322	108.3	-2.7
5	2483.50	63.2 PK	74.0	-10.8	1.16 H	322	66.0	-2.8
6	2483.50	44.8 AV	54.0	-9.2	1.16 H	322	47.6	-2.8
7	4874.00	42.5 PK	74.0	-31.5	1.38 H	147	40.8	1.7
8	4874.00	37.8 AV	54.0	-16.2	1.38 H	147	36.1	1.7
9	7311.00	48.6 PK	74.0	-25.4	1.37 H	301	41.4	7.2
10	7311.00	42.2 AV	54.0	-11.8	1.37 H	301	35.0	7.2

Antenna Polarity & Test Distance : Vertical at 3 m

No	Frequency (MHz)	Emission Level (dBuV/m)	Limit (dBuV/m)	Margin (dB)	Antenna Height (m)	Table Angle (Degree)	Raw Value (dBuV)	Correction Factor (dB/m)
1	2390.00	59.1 PK	74.0	-14.9	2.30 V	86	61.8	-2.7
2	2390.00	42.9 AV	54.0	-11.1	2.30 V	86	45.6	-2.7
3	*2437.00	106.1 PK			2.30 V	86	108.8	-2.7
4	*2437.00	103.6 AV			2.30 V	86	106.3	-2.7
5	2483.50	61.3 PK	74.0	-12.7	2.30 V	86	64.1	-2.8
6	2483.50	42.0 AV	54.0	-12.0	2.30 V	86	44.8	-2.8
7	4874.00	40.3 PK	74.0	-33.7	1.51 V	126	38.6	1.7
8	4874.00	33.0 AV	54.0	-21.0	1.51 V	126	31.3	1.7
9	7311.00	47.1 PK	74.0	-26.9	3.26 V	142	39.9	7.2
10	7311.00	38.5 AV	54.0	-15.5	3.26 V	142	31.3	7.2

Remarks:

1. Emission Level(dBuV/m) = Raw Value(dBuV) + Correction Factor(dB/m)
2. Correction Factor(dB/m) = Antenna Factor(dB/m) + Cable Factor(dB) – Pre-Amplifier Factor(dB)
3. Margin value = Emission Level – Limit value
4. The other emission levels were very low against the limit.
5. " * " : Fundamental frequency.

RF Mode	TX 802.11b	Channel	CH 11 : 2462 MHz
Frequency Range	1GHz ~ 25GHz	Detector Function	Peak (PK) Average (AV)

Antenna Polarity & Test Distance : Horizontal at 3 m

No	Frequency (MHz)	Emission Level (dBuV/m)	Limit (dBuV/m)	Margin (dB)	Antenna Height (m)	Table Angle (Degree)	Raw Value (dBuV)	Correction Factor (dB/m)
1	*2462.00	108.5 PK			1.15 H	326	111.3	-2.8
2	*2462.00	105.9 AV			1.15 H	326	108.7	-2.8
3	2483.50	59.7 PK	74.0	-14.3	1.15 H	326	62.5	-2.8
4	2483.50	52.3 AV	54.0	-1.7	1.15 H	326	55.1	-2.8
5	4924.00	42.1 PK	74.0	-31.9	1.32 H	140	40.3	1.8
6	4924.00	37.5 AV	54.0	-16.5	1.32 H	140	35.7	1.8
7	7386.00	48.3 PK	74.0	-25.7	1.41 H	303	40.9	7.4
8	7386.00	41.9 AV	54.0	-12.1	1.41 H	303	34.5	7.4

Antenna Polarity & Test Distance : Vertical at 3 m

No	Frequency (MHz)	Emission Level (dBuV/m)	Limit (dBuV/m)	Margin (dB)	Antenna Height (m)	Table Angle (Degree)	Raw Value (dBuV)	Correction Factor (dB/m)
1	*2462.00	106.5 PK			2.32 V	78	109.3	-2.8
2	*2462.00	103.8 AV			2.32 V	78	106.6	-2.8
3	2483.50	57.4 PK	74.0	-16.6	2.32 V	78	60.2	-2.8
4	2483.50	49.0 AV	54.0	-5.0	2.32 V	78	51.8	-2.8
5	4924.00	40.9 PK	74.0	-33.1	1.51 V	130	39.1	1.8
6	4924.00	33.4 AV	54.0	-20.6	1.51 V	130	31.6	1.8
7	7386.00	46.3 PK	74.0	-27.7	3.31 V	147	38.9	7.4
8	7386.00	38.0 AV	54.0	-16.0	3.31 V	147	30.6	7.4

Remarks:

1. Emission Level(dBuV/m) = Raw Value(dBuV) + Correction Factor(dB/m)
2. Correction Factor(dB/m) = Antenna Factor(dB/m) + Cable Factor(dB) – Pre-Amplifier Factor(dB)
3. Margin value = Emission Level – Limit value
4. The other emission levels were very low against the limit.
5. " * ": Fundamental frequency.

RF Mode	TX 802.11b	Channel	CH 12 : 2467 MHz
Frequency Range	1GHz ~ 25GHz	Detector Function	Peak (PK) Average (AV)

Antenna Polarity & Test Distance : Horizontal at 3 m

No	Frequency (MHz)	Emission Level (dBuV/m)	Limit (dBuV/m)	Margin (dB)	Antenna Height (m)	Table Angle (Degree)	Raw Value (dBuV)	Correction Factor (dB/m)
1	*2467.00	104.1 PK			1.15 H	330	106.9	-2.8
2	*2467.00	101.6 AV			1.15 H	330	104.4	-2.8
3	2483.50	60.3 PK	74.0	-13.7	1.15 H	330	63.1	-2.8
4	2483.50	50.5 AV	54.0	-3.5	1.15 H	330	53.3	-2.8
5	2484.10	59.5 PK	74.0	-14.5	1.15 H	330	62.3	-2.8
6	2484.10	52.0 AV	54.0	-2.0	1.15 H	330	54.8	-2.8
7	4934.00	42.4 PK	74.0	-31.6	1.33 H	141	40.6	1.8
8	4934.00	37.8 AV	54.0	-16.2	1.33 H	141	36.0	1.8
9	7401.00	48.7 PK	74.0	-25.3	1.40 H	305	41.2	7.5
10	7401.00	42.2 AV	54.0	-11.8	1.40 H	305	34.7	7.5

Antenna Polarity & Test Distance : Vertical at 3 m

No	Frequency (MHz)	Emission Level (dBuV/m)	Limit (dBuV/m)	Margin (dB)	Antenna Height (m)	Table Angle (Degree)	Raw Value (dBuV)	Correction Factor (dB/m)
1	*2467.00	100.8 PK			2.16 V	84	103.6	-2.8
2	*2467.00	98.2 AV			2.16 V	84	101.0	-2.8
3	2483.50	57.6 PK	74.0	-16.4	2.16 V	84	60.4	-2.8
4	2483.50	47.6 AV	54.0	-6.4	2.16 V	84	50.4	-2.8
5	4934.00	40.9 PK	74.0	-33.1	1.50 V	130	39.1	1.8
6	4934.00	33.4 AV	54.0	-20.6	1.50 V	130	31.6	1.8
7	7401.00	46.9 PK	74.0	-27.1	3.31 V	129	39.4	7.5
8	7401.00	38.2 AV	54.0	-15.8	3.31 V	129	30.7	7.5

Remarks:

1. Emission Level(dBuV/m) = Raw Value(dBuV) + Correction Factor(dB/m)
2. Correction Factor(dB/m) = Antenna Factor(dB/m) + Cable Factor(dB) – Pre-Amplifier Factor(dB)
3. Margin value = Emission Level – Limit value
4. The other emission levels were very low against the limit.
5. " * ": Fundamental frequency.

RF Mode	TX 802.11b	Channel	CH 13 : 2472 MHz
Frequency Range	1GHz ~ 25GHz	Detector Function	Peak (PK) Average (AV)

Antenna Polarity & Test Distance : Horizontal at 3 m

No	Frequency (MHz)	Emission Level (dBuV/m)	Limit (dBuV/m)	Margin (dB)	Antenna Height (m)	Table Angle (Degree)	Raw Value (dBuV)	Correction Factor (dB/m)
1	*2472.00	100.6 PK			1.16 H	326	103.4	-2.8
2	*2472.00	98.1 AV			1.16 H	326	100.9	-2.8
3	2487.50	59.5 PK	74.0	-14.5	1.16 H	326	62.3	-2.8
4	2487.50	52.1 AV	54.0	-1.9	1.16 H	326	54.9	-2.8
5	4944.00	42.8 PK	74.0	-31.2	1.43 H	132	41.0	1.8
6	4944.00	38.3 AV	54.0	-15.7	1.43 H	132	36.5	1.8
7	7416.00	48.5 PK	74.0	-25.5	1.36 H	306	41.0	7.5
8	7416.00	42.0 AV	54.0	-12.0	1.36 H	306	34.5	7.5

Antenna Polarity & Test Distance : Vertical at 3 m

No	Frequency (MHz)	Emission Level (dBuV/m)	Limit (dBuV/m)	Margin (dB)	Antenna Height (m)	Table Angle (Degree)	Raw Value (dBuV)	Correction Factor (dB/m)
1	*2472.00	96.4 PK			2.02 V	95	99.2	-2.8
2	*2472.00	94.0 AV			2.02 V	95	96.8	-2.8
3	2487.00	57.5 PK	74.0	-16.5	2.02 V	95	60.3	-2.8
4	2487.00	49.0 AV	54.0	-5.0	2.02 V	95	51.8	-2.8
5	4944.00	40.5 PK	74.0	-33.5	1.46 V	141	38.7	1.8
6	4944.00	33.0 AV	54.0	-21.0	1.46 V	141	31.2	1.8
7	7416.00	47.1 PK	74.0	-26.9	3.24 V	145	39.6	7.5
8	7416.00	38.3 AV	54.0	-15.7	3.24 V	145	30.8	7.5

Remarks:

1. Emission Level(dBuV/m) = Raw Value(dBuV) + Correction Factor(dB/m)
2. Correction Factor(dB/m) = Antenna Factor(dB/m) + Cable Factor(dB) – Pre-Amplifier Factor(dB)
3. Margin value = Emission Level – Limit value
4. The other emission levels were very low against the limit.
5. " * ": Fundamental frequency.

RF Mode	TX 802.11g	Channel	CH 1 : 2412 MHz
Frequency Range	1GHz ~ 25GHz	Detector Function	Peak (PK) Average (AV)

Antenna Polarity & Test Distance : Horizontal at 3 m

No	Frequency (MHz)	Emission Level (dBuV/m)	Limit (dBuV/m)	Margin (dB)	Antenna Height (m)	Table Angle (Degree)	Raw Value (dBuV)	Correction Factor (dB/m)
1	2390.00	71.7 PK	74.0	-2.3	1.14 H	314	74.4	-2.7
2	2390.00	52.0 AV	54.0	-2.0	1.14 H	314	54.7	-2.7
3	*2412.00	107.7 PK			1.14 H	314	110.4	-2.7
4	*2412.00	98.5 AV			1.14 H	314	101.2	-2.7
5	4824.00	42.5 PK	74.0	-31.5	1.36 H	132	40.7	1.8
6	4824.00	37.6 AV	54.0	-16.4	1.36 H	132	35.8	1.8

Antenna Polarity & Test Distance : Vertical at 3 m

No	Frequency (MHz)	Emission Level (dBuV/m)	Limit (dBuV/m)	Margin (dB)	Antenna Height (m)	Table Angle (Degree)	Raw Value (dBuV)	Correction Factor (dB/m)
1	2390.00	67.1 PK	74.0	-6.9	2.34 V	81	69.8	-2.7
2	2390.00	49.8 AV	54.0	-4.2	2.34 V	81	52.5	-2.7
3	*2412.00	106.7 PK			2.34 V	81	109.4	-2.7
4	*2412.00	97.7 AV			2.34 V	81	100.4	-2.7
5	4824.00	40.4 PK	74.0	-33.6	1.56 V	122	38.6	1.8
6	4824.00	33.3 AV	54.0	-20.7	1.56 V	122	31.5	1.8

Remarks:

1. Emission Level(dBuV/m) = Raw Value(dBuV) + Correction Factor(dB/m)
2. Correction Factor(dB/m) = Antenna Factor(dB/m) + Cable Factor(dB) – Pre-Amplifier Factor(dB)
3. Margin value = Emission Level – Limit value
4. The other emission levels were very low against the limit.
5. " * ": Fundamental frequency.

RF Mode	TX 802.11g	Channel	CH 6 : 2437 MHz
Frequency Range	1GHz ~ 25GHz	Detector Function	Peak (PK) Average (AV)

Antenna Polarity & Test Distance : Horizontal at 3 m

No	Frequency (MHz)	Emission Level (dBuV/m)	Limit (dBuV/m)	Margin (dB)	Antenna Height (m)	Table Angle (Degree)	Raw Value (dBuV)	Correction Factor (dB/m)
1	2390.00	61.6 PK	74.0	-12.4	1.12 H	313	64.3	-2.7
2	2390.00	45.3 AV	54.0	-8.7	1.12 H	313	48.0	-2.7
3	*2437.00	109.6 PK			1.12 H	313	112.3	-2.7
4	*2437.00	100.1 AV			1.12 H	313	102.8	-2.7
5	2483.50	62.7 PK	74.0	-11.3	1.12 H	313	65.5	-2.8
6	2483.50	44.7 AV	54.0	-9.3	1.12 H	313	47.5	-2.8
7	4874.00	42.5 PK	74.0	-31.5	1.33 H	146	40.8	1.7
8	4874.00	37.6 AV	54.0	-16.4	1.33 H	146	35.9	1.7
9	7311.00	54.6 PK	74.0	-19.4	1.45 H	147	47.4	7.2
10	7311.00	40.2 AV	54.0	-13.8	1.45 H	147	33.0	7.2

Antenna Polarity & Test Distance : Vertical at 3 m

No	Frequency (MHz)	Emission Level (dBuV/m)	Limit (dBuV/m)	Margin (dB)	Antenna Height (m)	Table Angle (Degree)	Raw Value (dBuV)	Correction Factor (dB/m)
1	2390.00	59.4 PK	74.0	-14.6	2.35 V	83	62.1	-2.7
2	2390.00	43.4 AV	54.0	-10.6	2.35 V	83	46.1	-2.7
3	*2437.00	108.2 PK			2.35 V	83	110.9	-2.7
4	*2437.00	99.2 AV			2.35 V	83	101.9	-2.7
5	2483.50	60.8 PK	74.0	-13.2	2.35 V	83	63.6	-2.8
6	2483.50	42.0 AV	54.0	-12.0	2.35 V	83	44.8	-2.8
7	4874.00	40.0 PK	74.0	-34.0	1.53 V	113	38.3	1.7
8	4874.00	33.0 AV	54.0	-21.0	1.53 V	113	31.3	1.7
9	7311.00	50.3 PK	74.0	-23.7	2.60 V	128	43.1	7.2
10	7311.00	37.0 AV	54.0	-17.0	2.60 V	128	29.8	7.2

Remarks:

1. Emission Level(dBuV/m) = Raw Value(dBuV) + Correction Factor(dB/m)
2. Correction Factor(dB/m) = Antenna Factor(dB/m) + Cable Factor(dB) – Pre-Amplifier Factor(dB)
3. Margin value = Emission Level – Limit value
4. The other emission levels were very low against the limit.
5. " * " : Fundamental frequency.

RF Mode	TX 802.11g	Channel	CH 11 : 2462 MHz
Frequency Range	1GHz ~ 25GHz	Detector Function	Peak (PK) Average (AV)

Antenna Polarity & Test Distance : Horizontal at 3 m

No	Frequency (MHz)	Emission Level (dBuV/m)	Limit (dBuV/m)	Margin (dB)	Antenna Height (m)	Table Angle (Degree)	Raw Value (dBuV)	Correction Factor (dB/m)
1	*2462.00	107.8 PK			1.09 H	311	110.6	-2.8
2	*2462.00	97.8 AV			1.09 H	311	100.6	-2.8
3	2483.50	70.8 PK	74.0	-3.2	1.09 H	311	73.6	-2.8
4	2483.50	52.3 AV	54.0	-1.7	1.09 H	311	55.1	-2.8
5	4924.00	42.4 PK	74.0	-31.6	1.28 H	145	40.6	1.8
6	4924.00	37.8 AV	54.0	-16.2	1.28 H	145	36.0	1.8
7	7386.00	54.7 PK	74.0	-19.3	1.44 H	143	47.3	7.4
8	7386.00	40.4 AV	54.0	-13.6	1.44 H	143	33.0	7.4

Antenna Polarity & Test Distance : Vertical at 3 m

No	Frequency (MHz)	Emission Level (dBuV/m)	Limit (dBuV/m)	Margin (dB)	Antenna Height (m)	Table Angle (Degree)	Raw Value (dBuV)	Correction Factor (dB/m)
1	*2462.00	105.0 PK			2.04 V	84	107.8	-2.8
2	*2462.00	96.1 AV			2.04 V	84	98.9	-2.8
3	2483.50	63.4 PK	74.0	-10.6	2.04 V	84	66.2	-2.8
4	2483.50	47.5 AV	54.0	-6.5	2.04 V	84	50.3	-2.8
5	4924.00	40.2 PK	74.0	-33.8	1.56 V	112	38.4	1.8
6	4924.00	33.5 AV	54.0	-20.5	1.56 V	112	31.7	1.8
7	7386.00	50.7 PK	74.0	-23.3	2.57 V	118	43.3	7.4
8	7386.00	37.2 AV	54.0	-16.8	2.57 V	118	29.8	7.4

Remarks:

1. Emission Level(dBuV/m) = Raw Value(dBuV) + Correction Factor(dB/m)
2. Correction Factor(dB/m) = Antenna Factor(dB/m) + Cable Factor(dB) – Pre-Amplifier Factor(dB)
3. Margin value = Emission Level – Limit value
4. The other emission levels were very low against the limit.
5. " * ": Fundamental frequency.

RF Mode	TX 802.11g	Channel	CH 12 : 2467 MHz
Frequency Range	1GHz ~ 25GHz	Detector Function	Peak (PK) Average (AV)

Antenna Polarity & Test Distance : Horizontal at 3 m

No	Frequency (MHz)	Emission Level (dBuV/m)	Limit (dBuV/m)	Margin (dB)	Antenna Height (m)	Table Angle (Degree)	Raw Value (dBuV)	Correction Factor (dB/m)
1	*2467.00	104.0 PK			1.25 H	305	106.8	-2.8
2	*2467.00	95.1 AV			1.25 H	305	97.9	-2.8
3	2483.50	57.8 PK	74.0	-16.2	1.25 H	305	60.6	-2.8
4	2483.50	46.4 AV	54.0	-7.6	1.25 H	305	49.2	-2.8
5	4934.00	42.0 PK	74.0	-32.0	1.31 H	151	40.2	1.8
6	4934.00	37.4 AV	54.0	-16.6	1.31 H	151	35.6	1.8
7	7401.00	54.1 PK	74.0	-19.9	1.42 H	140	46.6	7.5
8	7401.00	39.9 AV	54.0	-14.1	1.42 H	140	32.4	7.5

Antenna Polarity & Test Distance : Vertical at 3 m

No	Frequency (MHz)	Emission Level (dBuV/m)	Limit (dBuV/m)	Margin (dB)	Antenna Height (m)	Table Angle (Degree)	Raw Value (dBuV)	Correction Factor (dB/m)
1	*2467.00	102.7 PK			3.19 V	86	105.5	-2.8
2	*2467.00	93.9 AV			3.19 V	86	96.7	-2.8
3	2483.50	58.4 PK	74.0	-15.6	3.19 V	86	61.2	-2.8
4	2483.50	45.6 AV	54.0	-8.4	3.19 V	86	48.4	-2.8
5	4934.00	39.9 PK	74.0	-34.1	1.49 V	100	38.1	1.8
6	4934.00	32.8 AV	54.0	-21.2	1.49 V	100	31.0	1.8
7	7401.00	50.7 PK	74.0	-23.3	2.60 V	127	43.2	7.5
8	7401.00	37.2 AV	54.0	-16.8	2.60 V	127	29.7	7.5

Remarks:

1. Emission Level(dBuV/m) = Raw Value(dBuV) + Correction Factor(dB/m)
2. Correction Factor(dB/m) = Antenna Factor(dB/m) + Cable Factor(dB) – Pre-Amplifier Factor(dB)
3. Margin value = Emission Level – Limit value
4. The other emission levels were very low against the limit.
5. " * ": Fundamental frequency.

RF Mode	TX 802.11g	Channel	CH 13 : 2472 MHz
Frequency Range	1GHz ~ 25GHz	Detector Function	Peak (PK) Average (AV)

Antenna Polarity & Test Distance : Horizontal at 3 m

No	Frequency (MHz)	Emission Level (dBuV/m)	Limit (dBuV/m)	Margin (dB)	Antenna Height (m)	Table Angle (Degree)	Raw Value (dBuV)	Correction Factor (dB/m)
1	*2472.00	102.8 PK			1.11 H	308	105.6	-2.8
2	*2472.00	93.9 AV			1.11 H	308	96.7	-2.8
3	2483.50	59.6 PK	74.0	-14.4	1.11 H	308	62.4	-2.8
4	2483.50	47.4 AV	54.0	-6.6	1.11 H	308	50.2	-2.8
5	4944.00	41.8 PK	74.0	-32.2	1.33 H	140	40.0	1.8
6	4944.00	37.1 AV	54.0	-16.9	1.33 H	140	35.3	1.8
7	7416.00	55.0 PK	74.0	-19.0	1.41 H	160	47.5	7.5
8	7416.00	40.7 AV	54.0	-13.3	1.41 H	160	33.2	7.5

Antenna Polarity & Test Distance : Vertical at 3 m

No	Frequency (MHz)	Emission Level (dBuV/m)	Limit (dBuV/m)	Margin (dB)	Antenna Height (m)	Table Angle (Degree)	Raw Value (dBuV)	Correction Factor (dB/m)
1	*2472.00	101.2 PK			3.20 V	84	104.0	-2.8
2	*2472.00	92.3 AV			3.20 V	84	95.1	-2.8
3	2483.50	57.5 PK	74.0	-16.5	3.20 V	84	60.3	-2.8
4	2483.50	46.0 AV	54.0	-8.0	3.20 V	84	48.8	-2.8
5	4944.00	40.3 PK	74.0	-33.7	1.59 V	125	38.5	1.8
6	4944.00	33.4 AV	54.0	-20.6	1.59 V	125	31.6	1.8
7	7416.00	49.9 PK	74.0	-24.1	2.60 V	140	42.4	7.5
8	7416.00	36.6 AV	54.0	-17.4	2.60 V	140	29.1	7.5

Remarks:

1. Emission Level(dBuV/m) = Raw Value(dBuV) + Correction Factor(dB/m)
2. Correction Factor(dB/m) = Antenna Factor(dB/m) + Cable Factor(dB) – Pre-Amplifier Factor(dB)
3. Margin value = Emission Level – Limit value
4. The other emission levels were very low against the limit.
5. " * ": Fundamental frequency.

RF Mode	TX 802.11ax (HE20)	Channel	CH 1 : 2412 MHz
Frequency Range	1GHz ~ 25GHz	Detector Function	Peak (PK) Average (AV)

Antenna Polarity & Test Distance : Horizontal at 3 m

No	Frequency (MHz)	Emission Level (dBuV/m)	Limit (dBuV/m)	Margin (dB)	Antenna Height (m)	Table Angle (Degree)	Raw Value (dBuV)	Correction Factor (dB/m)
1	2390.00	69.2 PK	74.0	-4.8	1.13 H	312	71.9	-2.7
2	2390.00	52.1 AV	54.0	-1.9	1.13 H	312	54.8	-2.7
3	*2412.00	110.8 PK			1.13 H	312	113.5	-2.7
4	*2412.00	98.8 AV			1.13 H	312	101.5	-2.7
5	4824.00	41.9 PK	74.0	-32.1	1.26 H	110	40.1	1.8
6	4824.00	37.3 AV	54.0	-16.7	1.26 H	110	35.5	1.8

Antenna Polarity & Test Distance : Vertical at 3 m

No	Frequency (MHz)	Emission Level (dBuV/m)	Limit (dBuV/m)	Margin (dB)	Antenna Height (m)	Table Angle (Degree)	Raw Value (dBuV)	Correction Factor (dB/m)
1	2390.00	66.8 PK	74.0	-7.2	2.29 V	82	69.5	-2.7
2	2390.00	50.2 AV	54.0	-3.8	2.29 V	82	52.9	-2.7
3	*2412.00	108.1 PK			2.29 V	82	110.8	-2.7
4	*2412.00	97.0 AV			2.29 V	82	99.7	-2.7
5	4824.00	40.5 PK	74.0	-33.5	1.50 V	130	38.7	1.8
6	4824.00	33.8 AV	54.0	-20.2	1.50 V	130	32.0	1.8

Remarks:

1. Emission Level(dBuV/m) = Raw Value(dBuV) + Correction Factor(dB/m)
2. Correction Factor(dB/m) = Antenna Factor(dB/m) + Cable Factor(dB) – Pre-Amplifier Factor(dB)
3. Margin value = Emission Level – Limit value
4. The other emission levels were very low against the limit.
5. " * ": Fundamental frequency.

RF Mode	TX 802.11ax (HE20)	Channel	CH 6 : 2437 MHz
Frequency Range	1GHz ~ 25GHz	Detector Function	Peak (PK) Average (AV)

Antenna Polarity & Test Distance : Horizontal at 3 m

No	Frequency (MHz)	Emission Level (dBuV/m)	Limit (dBuV/m)	Margin (dB)	Antenna Height (m)	Table Angle (Degree)	Raw Value (dBuV)	Correction Factor (dB/m)
1	2390.00	61.5 PK	74.0	-12.5	1.35 H	309	64.2	-2.7
2	2390.00	45.1 AV	54.0	-8.9	1.35 H	309	47.8	-2.7
3	*2437.00	113.1 PK			1.35 H	309	115.8	-2.7
4	*2437.00	101.7 AV			1.35 H	309	104.4	-2.7
5	2483.50	62.8 PK	74.0	-11.2	1.35 H	309	65.6	-2.8
6	2483.50	44.5 AV	54.0	-9.5	1.35 H	309	47.3	-2.8
7	4874.00	41.9 PK	74.0	-32.1	1.30 H	126	40.2	1.7
8	4874.00	37.4 AV	54.0	-16.6	1.30 H	126	35.7	1.7
9	7311.00	55.0 PK	74.0	-19.0	1.36 H	173	47.8	7.2
10	7311.00	40.8 AV	54.0	-13.2	1.36 H	173	33.6	7.2

Antenna Polarity & Test Distance : Vertical at 3 m

No	Frequency (MHz)	Emission Level (dBuV/m)	Limit (dBuV/m)	Margin (dB)	Antenna Height (m)	Table Angle (Degree)	Raw Value (dBuV)	Correction Factor (dB/m)
1	2390.00	59.2 PK	74.0	-14.8	2.33 V	89	61.9	-2.7
2	2390.00	43.3 AV	54.0	-10.7	2.33 V	89	46.0	-2.7
3	*2437.00	111.3 PK			2.33 V	89	114.0	-2.7
4	*2437.00	100.1 AV			2.33 V	89	102.8	-2.7
5	2483.50	61.1 PK	74.0	-12.9	2.33 V	89	63.9	-2.8
6	2483.50	42.0 AV	54.0	-12.0	2.33 V	89	44.8	-2.8
7	4874.00	40.4 PK	74.0	-33.6	1.54 V	132	38.7	1.7
8	4874.00	33.8 AV	54.0	-20.2	1.54 V	132	32.1	1.7
9	7311.00	50.2 PK	74.0	-23.8	2.65 V	136	43.0	7.2
10	7311.00	36.8 AV	54.0	-17.2	2.65 V	136	29.6	7.2

Remarks:

1. Emission Level(dBuV/m) = Raw Value(dBuV) + Correction Factor(dB/m)
2. Correction Factor(dB/m) = Antenna Factor(dB/m) + Cable Factor(dB) – Pre-Amplifier Factor(dB)
3. Margin value = Emission Level – Limit value
4. The other emission levels were very low against the limit.
5. " * " : Fundamental frequency.

RF Mode	TX 802.11ax (HE20)	Channel	CH 11 : 2462 MHz
Frequency Range	1GHz ~ 25GHz	Detector Function	Peak (PK) Average (AV)

Antenna Polarity & Test Distance : Horizontal at 3 m

No	Frequency (MHz)	Emission Level (dBuV/m)	Limit (dBuV/m)	Margin (dB)	Antenna Height (m)	Table Angle (Degree)	Raw Value (dBuV)	Correction Factor (dB/m)
1	*2462.00	109.1 PK			1.17 H	314	111.9	-2.8
2	*2462.00	98.3 AV			1.17 H	314	101.1	-2.8
3	2483.90	67.3 PK	74.0	-6.7	1.17 H	314	70.1	-2.8
4	2483.90	52.0 AV	54.0	-2.0	1.17 H	314	54.8	-2.8
5	4924.00	42.0 PK	74.0	-32.0	1.32 H	148	40.2	1.8
6	4924.00	37.2 AV	54.0	-16.8	1.32 H	148	35.4	1.8
7	7386.00	54.4 PK	74.0	-19.6	1.42 H	152	47.0	7.4
8	7386.00	40.4 AV	54.0	-13.6	1.42 H	152	33.0	7.4

Antenna Polarity & Test Distance : Vertical at 3 m

No	Frequency (MHz)	Emission Level (dBuV/m)	Limit (dBuV/m)	Margin (dB)	Antenna Height (m)	Table Angle (Degree)	Raw Value (dBuV)	Correction Factor (dB/m)
1	*2462.00	106.8 PK			2.32 V	85	109.6	-2.8
2	*2462.00	95.8 AV			2.32 V	85	98.6	-2.8
3	2484.00	63.6 PK	74.0	-10.4	2.32 V	85	66.4	-2.8
4	2484.00	49.0 AV	54.0	-5.0	2.32 V	85	51.8	-2.8
5	4924.00	40.3 PK	74.0	-33.7	1.60 V	120	38.5	1.8
6	4924.00	33.3 AV	54.0	-20.7	1.60 V	120	31.5	1.8
7	7386.00	50.2 PK	74.0	-23.8	2.59 V	125	42.8	7.4
8	7386.00	37.1 AV	54.0	-16.9	2.59 V	125	29.7	7.4

Remarks:

1. Emission Level(dBuV/m) = Raw Value(dBuV) + Correction Factor(dB/m)
2. Correction Factor(dB/m) = Antenna Factor(dB/m) + Cable Factor(dB) – Pre-Amplifier Factor(dB)
3. Margin value = Emission Level – Limit value
4. The other emission levels were very low against the limit.
5. " * ": Fundamental frequency.

RF Mode	TX 802.11ax (HE20)	Channel	CH 12 : 2467 MHz
Frequency Range	1GHz ~ 25GHz	Detector Function	Peak (PK) Average (AV)

Antenna Polarity & Test Distance : Horizontal at 3 m

No	Frequency (MHz)	Emission Level (dBuV/m)	Limit (dBuV/m)	Margin (dB)	Antenna Height (m)	Table Angle (Degree)	Raw Value (dBuV)	Correction Factor (dB/m)
1	*2467.00	106.2 PK			1.11 H	310	109.0	-2.8
2	*2467.00	94.8 AV			1.11 H	310	97.6	-2.8
3	2483.50	61.0 PK	74.0	-13.0	1.11 H	310	63.8	-2.8
4	2483.50	47.2 AV	54.0	-6.8	1.11 H	310	50.0	-2.8
5	4934.00	41.9 PK	74.0	-32.1	1.37 H	145	40.1	1.8
6	4934.00	37.2 AV	54.0	-16.8	1.37 H	145	35.4	1.8
7	7401.00	55.1 PK	74.0	-18.9	1.42 H	170	47.6	7.5
8	7401.00	40.9 AV	54.0	-13.1	1.42 H	170	33.4	7.5

Antenna Polarity & Test Distance : Vertical at 3 m

No	Frequency (MHz)	Emission Level (dBuV/m)	Limit (dBuV/m)	Margin (dB)	Antenna Height (m)	Table Angle (Degree)	Raw Value (dBuV)	Correction Factor (dB/m)
1	*2467.00	104.6 PK			3.20 V	88	107.4	-2.8
2	*2467.00	93.5 AV			3.20 V	88	96.3	-2.8
3	2483.50	58.4 PK	74.0	-15.6	3.20 V	88	61.2	-2.8
4	2483.50	46.2 AV	54.0	-7.8	3.20 V	88	49.0	-2.8
5	4934.00	40.0 PK	74.0	-34.0	1.63 V	112	38.2	1.8
6	4934.00	33.0 AV	54.0	-21.0	1.63 V	112	31.2	1.8
7	7401.00	49.3 PK	74.0	-24.7	2.65 V	126	41.8	7.5
8	7401.00	36.1 AV	54.0	-17.9	2.65 V	126	28.6	7.5

Remarks:

1. Emission Level(dBuV/m) = Raw Value(dBuV) + Correction Factor(dB/m)
2. Correction Factor(dB/m) = Antenna Factor(dB/m) + Cable Factor(dB) – Pre-Amplifier Factor(dB)
3. Margin value = Emission Level – Limit value
4. The other emission levels were very low against the limit.
5. " * ": Fundamental frequency.

RF Mode	TX 802.11ax (HE20)	Channel	CH 13 : 2472 MHz
Frequency Range	1GHz ~ 25GHz	Detector Function	Peak (PK) Average (AV)

Antenna Polarity & Test Distance : Horizontal at 3 m

No	Frequency (MHz)	Emission Level (dBuV/m)	Limit (dBuV/m)	Margin (dB)	Antenna Height (m)	Table Angle (Degree)	Raw Value (dBuV)	Correction Factor (dB/m)
1	*2472.00	104.9 PK			1.09 H	304	107.7	-2.8
2	*2472.00	93.9 AV			1.09 H	304	96.7	-2.8
3	2483.50	64.3 PK	74.0	-9.7	1.09 H	304	67.1	-2.8
4	2483.50	47.7 AV	54.0	-6.3	1.09 H	304	50.5	-2.8
5	4944.00	41.9 PK	74.0	-32.1	1.38 H	142	40.1	1.8
6	4944.00	36.9 AV	54.0	-17.1	1.38 H	142	35.1	1.8
7	7416.00	54.2 PK	74.0	-19.8	1.37 H	166	46.7	7.5
8	7416.00	40.2 AV	54.0	-13.8	1.37 H	166	32.7	7.5

Antenna Polarity & Test Distance : Vertical at 3 m

No	Frequency (MHz)	Emission Level (dBuV/m)	Limit (dBuV/m)	Margin (dB)	Antenna Height (m)	Table Angle (Degree)	Raw Value (dBuV)	Correction Factor (dB/m)
1	*2472.00	103.5 PK			3.10 V	90	106.3	-2.8
2	*2472.00	92.4 AV			3.10 V	90	95.2	-2.8
3	2483.50	62.8 PK	74.0	-11.2	3.10 V	90	65.6	-2.8
4	2483.50	46.5 AV	54.0	-7.5	3.10 V	90	49.3	-2.8
5	4944.00	40.5 PK	74.0	-33.5	1.55 V	118	38.7	1.8
6	4944.00	33.6 AV	54.0	-20.4	1.55 V	118	31.8	1.8
7	7416.00	49.4 PK	74.0	-24.6	2.62 V	136	41.9	7.5
8	7416.00	36.2 AV	54.0	-17.8	2.62 V	136	28.7	7.5

Remarks:

1. Emission Level(dBuV/m) = Raw Value(dBuV) + Correction Factor(dB/m)
2. Correction Factor(dB/m) = Antenna Factor(dB/m) + Cable Factor(dB) – Pre-Amplifier Factor(dB)
3. Margin value = Emission Level – Limit value
4. The other emission levels were very low against the limit.
5. " * ": Fundamental frequency.

RF Mode	TX 802.11ax (HE40)	Channel	CH 3 : 2422 MHz
Frequency Range	1GHz ~ 25GHz	Detector Function	Peak (PK) Average (AV)

Antenna Polarity & Test Distance : Horizontal at 3 m

No	Frequency (MHz)	Emission Level (dBuV/m)	Limit (dBuV/m)	Margin (dB)	Antenna Height (m)	Table Angle (Degree)	Raw Value (dBuV)	Correction Factor (dB/m)
1	2388.00	71.8 PK	74.0	-2.2	1.18 H	311	74.5	-2.7
2	2388.00	51.1 AV	54.0	-2.9	1.18 H	311	53.8	-2.7
3	*2422.00	105.8 PK			1.18 H	311	108.5	-2.7
4	*2422.00	95.9 AV			1.18 H	311	98.6	-2.7
5	4844.00	41.1 PK	74.0	-32.9	1.36 H	152	39.3	1.8
6	4844.00	36.4 AV	54.0	-17.6	1.36 H	152	34.6	1.8
7	7266.00	54.6 PK	74.0	-19.4	1.27 H	186	47.3	7.3
8	7266.00	40.4 AV	54.0	-13.6	1.27 H	186	33.1	7.3

Antenna Polarity & Test Distance : Vertical at 3 m

No	Frequency (MHz)	Emission Level (dBuV/m)	Limit (dBuV/m)	Margin (dB)	Antenna Height (m)	Table Angle (Degree)	Raw Value (dBuV)	Correction Factor (dB/m)
1	2388.20	71.3 PK	74.0	-2.7	2.26 V	82	74.0	-2.7
2	2388.20	51.1 AV	54.0	-2.9	2.26 V	82	53.8	-2.7
3	*2422.00	105.6 PK			2.26 V	82	108.3	-2.7
4	*2422.00	94.0 AV			2.26 V	82	96.7	-2.7
5	4844.00	40.1 PK	74.0	-33.9	1.50 V	104	38.3	1.8
6	4844.00	33.5 AV	54.0	-20.5	1.50 V	104	31.7	1.8
7	7266.00	49.6 PK	74.0	-24.4	2.66 V	134	42.3	7.3
8	7266.00	36.2 AV	54.0	-17.8	2.66 V	134	28.9	7.3

Remarks:

1. Emission Level(dBuV/m) = Raw Value(dBuV) + Correction Factor(dB/m)
2. Correction Factor(dB/m) = Antenna Factor(dB/m) + Cable Factor(dB) – Pre-Amplifier Factor(dB)
3. Margin value = Emission Level – Limit value
4. The other emission levels were very low against the limit.
5. " * ": Fundamental frequency.

RF Mode	TX 802.11ax (HE40)	Channel	CH 6 : 2437 MHz
Frequency Range	1GHz ~ 25GHz	Detector Function	Peak (PK) Average (AV)

Antenna Polarity & Test Distance : Horizontal at 3 m

No	Frequency (MHz)	Emission Level (dBuV/m)	Limit (dBuV/m)	Margin (dB)	Antenna Height (m)	Table Angle (Degree)	Raw Value (dBuV)	Correction Factor (dB/m)
1	2390.00	68.8 PK	74.0	-5.2	1.16 H	316	71.5	-2.7
2	2390.00	52.0 AV	54.0	-2.0	1.16 H	316	54.7	-2.7
3	*2437.00	106.3 PK			1.16 H	316	109.0	-2.7
4	*2437.00	96.2 AV			1.16 H	316	98.9	-2.7
5	2483.50	68.2 PK	74.0	-5.8	1.16 H	316	71.0	-2.8
6	2483.50	51.9 AV	54.0	-2.1	1.16 H	316	54.7	-2.8
7	4874.00	41.6 PK	74.0	-32.4	1.40 H	152	39.9	1.7
8	4874.00	36.6 AV	54.0	-17.4	1.40 H	152	34.9	1.7
9	7311.00	54.8 PK	74.0	-19.2	1.31 H	177	47.6	7.2
10	7311.00	40.6 AV	54.0	-13.4	1.31 H	177	33.4	7.2

Antenna Polarity & Test Distance : Vertical at 3 m

No	Frequency (MHz)	Emission Level (dBuV/m)	Limit (dBuV/m)	Margin (dB)	Antenna Height (m)	Table Angle (Degree)	Raw Value (dBuV)	Correction Factor (dB/m)
1	2390.00	66.3 PK	74.0	-7.7	2.28 V	77	69.0	-2.7
2	2390.00	50.1 AV	54.0	-3.9	2.28 V	77	52.8	-2.7
3	*2437.00	106.1 PK			2.28 V	77	108.8	-2.7
4	*2437.00	94.6 AV			2.28 V	77	97.3	-2.7
5	2483.50	67.1 PK	74.0	-6.9	2.28 V	77	69.9	-2.8
6	2483.50	50.8 AV	54.0	-3.2	2.28 V	77	53.6	-2.8
7	4874.00	41.1 PK	74.0	-32.9	1.50 V	109	39.4	1.7
8	4874.00	34.1 AV	54.0	-19.9	1.50 V	109	32.4	1.7
9	7311.00	49.7 PK	74.0	-24.3	2.57 V	129	42.5	7.2
10	7311.00	36.5 AV	54.0	-17.5	2.57 V	129	29.3	7.2

Remarks:

1. Emission Level(dBuV/m) = Raw Value(dBuV) + Correction Factor(dB/m)
2. Correction Factor(dB/m) = Antenna Factor(dB/m) + Cable Factor(dB) – Pre-Amplifier Factor(dB)
3. Margin value = Emission Level – Limit value
4. The other emission levels were very low against the limit.
5. " * ": Fundamental frequency.

RF Mode	TX 802.11ax (HE40)	Channel	CH 9 : 2452 MHz
Frequency Range	1GHz ~ 25GHz	Detector Function	Peak (PK) Average (AV)

Antenna Polarity & Test Distance : Horizontal at 3 m

No	Frequency (MHz)	Emission Level (dBuV/m)	Limit (dBuV/m)	Margin (dB)	Antenna Height (m)	Table Angle (Degree)	Raw Value (dBuV)	Correction Factor (dB/m)
1	*2452.00	106.4 PK			1.22 H	330	109.1	-2.7
2	*2452.00	95.3 AV			1.22 H	330	98.0	-2.7
3	2487.70	72.4 PK	74.0	-1.6	1.22 H	330	75.2	-2.8
4	2487.70	52.0 AV	54.0	-2.0	1.22 H	330	54.8	-2.8
5	4904.00	42.5 PK	74.0	-31.5	1.40 H	137	40.8	1.7
6	4904.00	37.3 AV	54.0	-16.7	1.40 H	137	35.6	1.7
7	7356.00	54.0 PK	74.0	-20.0	1.41 H	153	46.7	7.3
8	7356.00	40.0 AV	54.0	-14.0	1.41 H	153	32.7	7.3

Antenna Polarity & Test Distance : Vertical at 3 m

No	Frequency (MHz)	Emission Level (dBuV/m)	Limit (dBuV/m)	Margin (dB)	Antenna Height (m)	Table Angle (Degree)	Raw Value (dBuV)	Correction Factor (dB/m)
1	*2452.00	103.5 PK			2.37 V	80	106.2	-2.7
2	*2452.00	92.0 AV			2.37 V	80	94.7	-2.7
3	2488.10	66.5 PK	74.0	-7.5	2.37 V	80	69.3	-2.8
4	2488.10	48.2 AV	54.0	-5.8	2.37 V	80	51.0	-2.8
5	4904.00	39.8 PK	74.0	-34.2	1.57 V	129	38.1	1.7
6	4904.00	33.1 AV	54.0	-20.9	1.57 V	129	31.4	1.7
7	7356.00	49.5 PK	74.0	-24.5	2.58 V	151	42.2	7.3
8	7356.00	36.4 AV	54.0	-17.6	2.58 V	151	29.1	7.3

Remarks:

1. Emission Level(dBuV/m) = Raw Value(dBuV) + Correction Factor(dB/m)
2. Correction Factor(dB/m) = Antenna Factor(dB/m) + Cable Factor(dB) – Pre-Amplifier Factor(dB)
3. Margin value = Emission Level – Limit value
4. The other emission levels were very low against the limit.
5. " * ": Fundamental frequency.

RF Mode	TX 802.11ax (HE40)	Channel	CH 10 : 2457 MHz
Frequency Range	1GHz ~ 25GHz	Detector Function	Peak (PK) Average (AV)

Antenna Polarity & Test Distance : Horizontal at 3 m

No	Frequency (MHz)	Emission Level (dBuV/m)	Limit (dBuV/m)	Margin (dB)	Antenna Height (m)	Table Angle (Degree)	Raw Value (dBuV)	Correction Factor (dB/m)
1	*2457.00	106.2 PK			1.22 H	330	108.9	-2.7
2	*2457.00	95.1 AV			1.22 H	330	97.8	-2.7
3	2493.00	69.1 PK	74.0	-4.9	1.22 H	330	71.9	-2.8
4	2493.00	52.2 AV	54.0	-1.8	1.22 H	330	55.0	-2.8
5	4914.00	41.3 PK	74.0	-32.7	1.33 H	144	39.6	1.7
6	4914.00	36.4 AV	54.0	-17.6	1.33 H	144	34.7	1.7
7	7371.00	53.7 PK	74.0	-20.3	1.42 H	173	46.4	7.3
8	7371.00	39.8 AV	54.0	-14.2	1.42 H	173	32.5	7.3

Antenna Polarity & Test Distance : Vertical at 3 m

No	Frequency (MHz)	Emission Level (dBuV/m)	Limit (dBuV/m)	Margin (dB)	Antenna Height (m)	Table Angle (Degree)	Raw Value (dBuV)	Correction Factor (dB/m)
1	*2457.00	103.7 PK			2.30 V	82	106.4	-2.7
2	*2457.00	91.8 AV			2.30 V	82	94.5	-2.7
3	2483.50	65.9 PK	74.0	-8.1	2.30 V	82	68.7	-2.8
4	2483.50	47.5 AV	54.0	-6.5	2.30 V	82	50.3	-2.8
5	4914.00	40.0 PK	74.0	-34.0	1.61 V	130	38.3	1.7
6	4914.00	33.2 AV	54.0	-20.8	1.61 V	130	31.5	1.7
7	7371.00	49.4 PK	74.0	-24.6	2.58 V	150	42.1	7.3
8	7371.00	36.5 AV	54.0	-17.5	2.58 V	150	29.2	7.3

Remarks:

1. Emission Level(dBuV/m) = Raw Value(dBuV) + Correction Factor(dB/m)
2. Correction Factor(dB/m) = Antenna Factor(dB/m) + Cable Factor(dB) – Pre-Amplifier Factor(dB)
3. Margin value = Emission Level – Limit value
4. The other emission levels were very low against the limit.
5. " * ": Fundamental frequency.

RF Mode	TX 802.11ax (HE40)	Channel	CH 11 : 2462 MHz
Frequency Range	1GHz ~ 25GHz	Detector Function	Peak (PK) Average (AV)

Antenna Polarity & Test Distance : Horizontal at 3 m

No	Frequency (MHz)	Emission Level (dBuV/m)	Limit (dBuV/m)	Margin (dB)	Antenna Height (m)	Table Angle (Degree)	Raw Value (dBuV)	Correction Factor (dB/m)
1	*2462.00	105.9 PK			1.03 H	328	108.7	-2.8
2	*2462.00	94.2 AV			1.03 H	328	97.0	-2.8
3	2483.50	68.3 PK	74.0	-5.7	1.03 H	328	71.1	-2.8
4	2483.50	51.9 AV	54.0	-2.1	1.03 H	328	54.7	-2.8
5	2498.30	69.4 PK	74.0	-4.6	1.03 H	328	72.2	-2.8
6	2498.30	50.5 AV	54.0	-3.5	1.03 H	328	53.3	-2.8
7	4924.00	41.8 PK	74.0	-32.2	1.43 H	139	40.0	1.8
8	4924.00	36.5 AV	54.0	-17.5	1.43 H	139	34.7	1.8
9	7386.00	53.6 PK	74.0	-20.4	1.36 H	160	46.2	7.4
10	7386.00	39.7 AV	54.0	-14.3	1.36 H	160	32.3	7.4

Antenna Polarity & Test Distance : Vertical at 3 m

No	Frequency (MHz)	Emission Level (dBuV/m)	Limit (dBuV/m)	Margin (dB)	Antenna Height (m)	Table Angle (Degree)	Raw Value (dBuV)	Correction Factor (dB/m)
1	*2462.00	103.1 PK			2.01 V	140	105.9	-2.8
2	*2462.00	91.3 AV			2.01 V	140	94.1	-2.8
3	2483.50	64.8 PK	74.0	-9.2	2.01 V	140	67.6	-2.8
4	2483.50	47.7 AV	54.0	-6.3	2.01 V	140	50.5	-2.8
5	4924.00	40.2 PK	74.0	-33.8	1.54 V	107	38.4	1.8
6	4924.00	33.3 AV	54.0	-20.7	1.54 V	107	31.5	1.8
7	7386.00	49.3 PK	74.0	-24.7	2.58 V	126	41.9	7.4
8	7386.00	36.3 AV	54.0	-17.7	2.58 V	126	28.9	7.4

Remarks:

1. Emission Level(dBuV/m) = Raw Value(dBuV) + Correction Factor(dB/m)
2. Correction Factor(dB/m) = Antenna Factor(dB/m) + Cable Factor(dB) – Pre-Amplifier Factor(dB)
3. Margin value = Emission Level – Limit value
4. The other emission levels were very low against the limit.
5. " * ": Fundamental frequency.

RF Mode	TX 20MHz Preamble 802.11ax (RU26)	Channel	CH 1 : 2412 MHz
Frequency Range	1GHz ~ 25GHz	Detector Function	Peak (PK) Average (AV)

Antenna Polarity & Test Distance : Horizontal at 3 m

No	Frequency (MHz)	Emission Level (dBuV/m)	Limit (dBuV/m)	Margin (dB)	Antenna Height (m)	Table Angle (Degree)	Raw Value (dBuV)	Correction Factor (dB/m)
1	2387.00	67.7 PK	74.0	-6.3	2.34 H	118	70.4	-2.7
2	2387.00	46.3 AV	54.0	-7.7	2.34 H	118	49.0	-2.7
3	2389.66	72.3 PK	74.0	-1.7	2.34 H	118	75.0	-2.7
4	2389.66	45.5 AV	54.0	-8.5	2.34 H	118	48.2	-2.7
5	*2412.00	119.1 PK			2.34 H	118	121.8	-2.7
6	*2412.00	107.9 AV			2.34 H	118	110.6	-2.7
7	4824.00	46.3 PK	74.0	-27.7	1.76 H	184	44.5	1.8
8	4824.00	35.5 AV	54.0	-18.5	1.76 H	184	33.7	1.8

Antenna Polarity & Test Distance : Vertical at 3 m

No	Frequency (MHz)	Emission Level (dBuV/m)	Limit (dBuV/m)	Margin (dB)	Antenna Height (m)	Table Angle (Degree)	Raw Value (dBuV)	Correction Factor (dB/m)
1	2390.00	66.9 PK	74.0	-7.1	1.30 V	160	69.6	-2.7
2	2390.00	43.8 AV	54.0	-10.2	1.30 V	160	46.5	-2.7
3	*2412.00	112.8 PK			1.30 V	160	115.5	-2.7
4	*2412.00	101.3 AV			1.30 V	160	104.0	-2.7
5	4824.00	43.0 PK	74.0	-31.0	1.49 V	116	41.2	1.8
6	4824.00	31.5 AV	54.0	-22.5	1.49 V	116	29.7	1.8

Remarks:

1. Emission Level(dBuV/m) = Raw Value(dBuV) + Correction Factor(dB/m)
2. Correction Factor(dB/m) = Antenna Factor(dB/m) + Cable Factor(dB) – Pre-Amplifier Factor(dB)
3. Margin value = Emission Level – Limit value
4. The other emission levels were very low against the limit.
5. " * " : Fundamental frequency.

RF Mode	TX 20MHz Preamble 802.11ax (RU26)	Channel	CH 6 : 2437 MHz
Frequency Range	1GHz ~ 25GHz	Detector Function	Peak (PK) Average (AV)

Antenna Polarity & Test Distance : Horizontal at 3 m

No	Frequency (MHz)	Emission Level (dBuV/m)	Limit (dBuV/m)	Margin (dB)	Antenna Height (m)	Table Angle (Degree)	Raw Value (dBuV)	Correction Factor (dB/m)
1	2390.00	56.8 PK	74.0	-17.2	1.20 H	298	59.5	-2.7
2	2390.00	43.7 AV	54.0	-10.3	1.20 H	298	46.4	-2.7
3	*2437.00	121.3 PK			1.20 H	298	124.0	-2.7
4	*2437.00	110.8 AV			1.20 H	298	113.5	-2.7
5	2483.50	57.2 PK	74.0	-16.8	1.20 H	298	60.0	-2.8
6	2483.50	43.2 AV	54.0	-10.8	1.20 H	298	46.0	-2.8
7	4874.00	45.8 PK	74.0	-28.2	1.80 H	182	44.1	1.7
8	4874.00	35.1 AV	54.0	-18.9	1.80 H	182	33.4	1.7
9	7311.00	66.2 PK	74.0	-7.8	1.95 H	108	59.0	7.2
10	7311.00	50.6 AV	54.0	-3.4	1.95 H	108	43.4	7.2

Antenna Polarity & Test Distance : Vertical at 3 m

No	Frequency (MHz)	Emission Level (dBuV/m)	Limit (dBuV/m)	Margin (dB)	Antenna Height (m)	Table Angle (Degree)	Raw Value (dBuV)	Correction Factor (dB/m)
1	2390.00	54.9 PK	74.0	-19.1	1.44 V	141	57.6	-2.7
2	2390.00	41.6 AV	54.0	-12.4	1.44 V	141	44.3	-2.7
3	*2437.00	115.3 PK			1.44 V	141	118.0	-2.7
4	*2437.00	104.1 AV			1.44 V	141	106.8	-2.7
5	2483.50	56.3 PK	74.0	-17.7	1.44 V	141	59.1	-2.8
6	2483.50	42.3 AV	54.0	-11.7	1.44 V	141	45.1	-2.8
7	4874.00	42.6 PK	74.0	-31.4	1.43 V	127	40.9	1.7
8	4874.00	31.2 AV	54.0	-22.8	1.43 V	127	29.5	1.7
9	7311.00	62.4 PK	74.0	-11.6	3.27 V	150	55.2	7.2
10	7311.00	46.7 AV	54.0	-7.3	3.27 V	150	39.5	7.2

Remarks:

1. Emission Level(dBuV/m) = Raw Value(dBuV) + Correction Factor(dB/m)
2. Correction Factor(dB/m) = Antenna Factor(dB/m) + Cable Factor(dB) – Pre-Amplifier Factor(dB)
3. Margin value = Emission Level – Limit value
4. The other emission levels were very low against the limit.
5. " * ": Fundamental frequency.

RF Mode	TX 20MHz Preamble 802.11ax (RU26)	Channel	CH 11 : 2462 MHz
Frequency Range	1GHz ~ 25GHz	Detector Function	Peak (PK) Average (AV)

Antenna Polarity & Test Distance : Horizontal at 3 m

No	Frequency (MHz)	Emission Level (dBuV/m)	Limit (dBuV/m)	Margin (dB)	Antenna Height (m)	Table Angle (Degree)	Raw Value (dBuV)	Correction Factor (dB/m)
1	*2462.00	121.2 PK			2.49 H	126	124.0	-2.8
2	*2462.00	108.6 AV			2.49 H	126	111.4	-2.8
3	2483.50	72.0 PK	74.0	-2.0	2.49 H	126	74.8	-2.8
4	2483.50	45.5 AV	54.0	-8.5	2.49 H	126	48.3	-2.8
5	4924.00	46.3 PK	74.0	-27.7	1.84 H	178	44.5	1.8
6	4924.00	35.4 AV	54.0	-18.6	1.84 H	178	33.6	1.8
7	7386.00	64.3 PK	74.0	-9.7	2.01 H	106	56.9	7.4
8	7386.00	46.8 AV	54.0	-7.2	2.01 H	106	39.4	7.4

Antenna Polarity & Test Distance : Vertical at 3 m

No	Frequency (MHz)	Emission Level (dBuV/m)	Limit (dBuV/m)	Margin (dB)	Antenna Height (m)	Table Angle (Degree)	Raw Value (dBuV)	Correction Factor (dB/m)
1	*2462.00	112.4 PK			1.50 V	140	115.2	-2.8
2	*2462.00	100.6 AV			1.50 V	140	103.4	-2.8
3	2483.50	65.8 PK	74.0	-8.2	1.50 V	140	68.6	-2.8
4	2483.50	43.5 AV	54.0	-10.5	1.50 V	140	46.3	-2.8
5	4924.00	42.6 PK	74.0	-31.4	1.46 V	117	40.8	1.8
6	4924.00	31.0 AV	54.0	-23.0	1.46 V	117	29.2	1.8
7	7386.00	57.6 PK	74.0	-16.4	3.30 V	164	50.2	7.4
8	7386.00	42.8 AV	54.0	-11.2	3.30 V	164	35.4	7.4

Remarks:

1. Emission Level(dBuV/m) = Raw Value(dBuV) + Correction Factor(dB/m)
2. Correction Factor(dB/m) = Antenna Factor(dB/m) + Cable Factor(dB) – Pre-Amplifier Factor(dB)
3. Margin value = Emission Level – Limit value
4. The other emission levels were very low against the limit.
5. " * ": Fundamental frequency.

RF Mode	TX 20MHz Preamble 802.11ax (RU26)	Channel	CH 12 : 2467 MHz
Frequency Range	1GHz ~ 25GHz	Detector Function	Peak (PK) Average (AV)

Antenna Polarity & Test Distance : Horizontal at 3 m

No	Frequency (MHz)	Emission Level (dBuV/m)	Limit (dBuV/m)	Margin (dB)	Antenna Height (m)	Table Angle (Degree)	Raw Value (dBuV)	Correction Factor (dB/m)
1	*2467.00	116.3 PK			2.74 H	127	119.1	-2.8
2	*2467.00	104.7 AV			2.74 H	127	107.5	-2.8
3	2485.14	72.3 PK	74.0	-1.7	2.74 H	127	75.1	-2.8
4	2485.14	45.3 AV	54.0	-8.7	2.74 H	127	48.1	-2.8
5	4934.00	45.5 PK	74.0	-28.5	1.83 H	176	43.7	1.8
6	4934.00	34.6 AV	54.0	-19.4	1.83 H	176	32.8	1.8
7	7401.00	64.4 PK	74.0	-9.6	2.02 H	117	56.9	7.5
8	7401.00	47.0 AV	54.0	-7.0	2.02 H	117	39.5	7.5

Antenna Polarity & Test Distance : Vertical at 3 m

No	Frequency (MHz)	Emission Level (dBuV/m)	Limit (dBuV/m)	Margin (dB)	Antenna Height (m)	Table Angle (Degree)	Raw Value (dBuV)	Correction Factor (dB/m)
1	*2467.00	110.7 PK			1.54 V	142	113.5	-2.8
2	*2467.00	97.2 AV			1.54 V	142	100.0	-2.8
3	2485.00	68.9 PK	74.0	-5.1	1.54 V	142	71.7	-2.8
4	2485.00	43.4 AV	54.0	-10.6	1.54 V	142	46.2	-2.8
5	4934.00	42.6 PK	74.0	-31.4	1.46 V	132	40.8	1.8
6	4934.00	30.7 AV	54.0	-23.3	1.46 V	132	28.9	1.8
7	7401.00	58.2 PK	74.0	-15.8	3.29 V	170	50.7	7.5
8	7401.00	43.1 AV	54.0	-10.9	3.29 V	170	35.6	7.5

Remarks:

1. Emission Level(dBuV/m) = Raw Value(dBuV) + Correction Factor(dB/m)
2. Correction Factor(dB/m) = Antenna Factor(dB/m) + Cable Factor(dB) – Pre-Amplifier Factor(dB)
3. Margin value = Emission Level – Limit value
4. The other emission levels were very low against the limit.
5. " * ": Fundamental frequency.

RF Mode	TX 20MHz Preamble 802.11ax (RU26)	Channel	CH 13 : 2472 MHz
Frequency Range	1GHz ~ 25GHz	Detector Function	Peak (PK) Average (AV)

Antenna Polarity & Test Distance : Horizontal at 3 m

No	Frequency (MHz)	Emission Level (dBuV/m)	Limit (dBuV/m)	Margin (dB)	Antenna Height (m)	Table Angle (Degree)	Raw Value (dBuV)	Correction Factor (dB/m)
1	*2472.00	112.1 PK			1.69 H	321	114.9	-2.8
2	*2472.00	100.3 AV			1.69 H	321	103.1	-2.8
3	2483.50	72.4 PK	74.0	-1.6	1.69 H	321	75.2	-2.8
4	2483.50	45.8 AV	54.0	-8.2	1.69 H	321	48.6	-2.8
5	4944.00	45.1 PK	74.0	-28.9	1.79 H	166	43.3	1.8
6	4944.00	34.7 AV	54.0	-19.3	1.79 H	166	32.9	1.8
7	7416.00	64.4 PK	74.0	-9.6	2.05 H	106	56.9	7.5
8	7416.00	47.1 AV	54.0	-6.9	2.05 H	106	39.6	7.5

Antenna Polarity & Test Distance : Vertical at 3 m

No	Frequency (MHz)	Emission Level (dBuV/m)	Limit (dBuV/m)	Margin (dB)	Antenna Height (m)	Table Angle (Degree)	Raw Value (dBuV)	Correction Factor (dB/m)
1	*2472.00	106.9 PK			1.59 V	161	109.7	-2.8
2	*2472.00	94.2 AV			1.59 V	161	97.0	-2.8
3	2484.17	65.3 PK	74.0	-8.7	1.59 V	161	68.1	-2.8
4	2484.17	43.4 AV	54.0	-10.6	1.59 V	161	46.2	-2.8
5	4944.00	42.7 PK	74.0	-31.3	1.40 V	128	40.9	1.8
6	4944.00	30.8 AV	54.0	-23.2	1.40 V	128	29.0	1.8
7	7416.00	57.4 PK	74.0	-16.6	3.25 V	159	49.9	7.5
8	7416.00	42.8 AV	54.0	-11.2	3.25 V	159	35.3	7.5

Remarks:

1. Emission Level(dBuV/m) = Raw Value(dBuV) + Correction Factor(dB/m)
2. Correction Factor(dB/m) = Antenna Factor(dB/m) + Cable Factor(dB) – Pre-Amplifier Factor(dB)
3. Margin value = Emission Level – Limit value
4. The other emission levels were very low against the limit.
5. " * ": Fundamental frequency.

RF Mode	TX 20MHz Preamble 802.11ax (RU52)	Channel	CH 1 : 2412 MHz
Frequency Range	1GHz ~ 25GHz	Detector Function	Peak (PK) Average (AV)

Antenna Polarity & Test Distance : Horizontal at 3 m

No	Frequency (MHz)	Emission Level (dBuV/m)	Limit (dBuV/m)	Margin (dB)	Antenna Height (m)	Table Angle (Degree)	Raw Value (dBuV)	Correction Factor (dB/m)
1	2388.31	72.3 PK	74.0	-1.7	2.28 H	119	75.0	-2.7
2	2388.31	47.4 AV	54.0	-6.6	2.28 H	119	50.1	-2.7
3	2390.00	69.5 PK	74.0	-4.5	2.28 H	119	72.2	-2.7
4	2390.00	48.0 AV	54.0	-6.0	2.28 H	119	50.7	-2.7
5	*2412.00	119.1 PK			2.28 H	119	121.8	-2.7
6	*2412.00	107.7 AV			2.28 H	119	110.4	-2.7
7	4824.00	46.2 PK	74.0	-27.8	1.81 H	179	44.4	1.8
8	4824.00	35.3 AV	54.0	-18.7	1.81 H	179	33.5	1.8

Antenna Polarity & Test Distance : Vertical at 3 m

No	Frequency (MHz)	Emission Level (dBuV/m)	Limit (dBuV/m)	Margin (dB)	Antenna Height (m)	Table Angle (Degree)	Raw Value (dBuV)	Correction Factor (dB/m)
1	2388.00	65.2 PK	74.0	-8.8	1.35 V	158	67.9	-2.7
2	2388.00	44.4 AV	54.0	-9.6	1.35 V	158	47.1	-2.7
3	*2412.00	112.2 PK			1.35 V	158	114.9	-2.7
4	*2412.00	100.9 AV			1.35 V	158	103.6	-2.7
5	4824.00	41.9 PK	74.0	-32.1	1.48 V	138	40.1	1.8
6	4824.00	30.8 AV	54.0	-23.2	1.48 V	138	29.0	1.8

Remarks:

1. Emission Level(dBuV/m) = Raw Value(dBuV) + Correction Factor(dB/m)
2. Correction Factor(dB/m) = Antenna Factor(dB/m) + Cable Factor(dB) – Pre-Amplifier Factor(dB)
3. Margin value = Emission Level – Limit value
4. The other emission levels were very low against the limit.
5. " * " : Fundamental frequency.

RF Mode	TX 20MHz Preamble 802.11ax (RU52)	Channel	CH 6 : 2437 MHz
Frequency Range	1GHz ~ 25GHz	Detector Function	Peak (PK) Average (AV)

Antenna Polarity & Test Distance : Horizontal at 3 m

No	Frequency (MHz)	Emission Level (dBuV/m)	Limit (dBuV/m)	Margin (dB)	Antenna Height (m)	Table Angle (Degree)	Raw Value (dBuV)	Correction Factor (dB/m)
1	2390.00	57.9 PK	74.0	-16.1	2.30 H	107	60.6	-2.7
2	2390.00	44.5 AV	54.0	-9.5	2.30 H	107	47.2	-2.7
3	*2437.00	121.4 PK			2.30 H	107	124.1	-2.7
4	*2437.00	108.9 AV			2.30 H	107	111.6	-2.7
5	2483.50	58.2 PK	74.0	-15.8	2.30 H	107	61.0	-2.8
6	2483.50	44.3 AV	54.0	-9.7	2.30 H	107	47.1	-2.8
7	4874.00	45.5 PK	74.0	-28.5	1.75 H	193	43.8	1.7
8	4874.00	35.0 AV	54.0	-19.0	1.75 H	193	33.3	1.7
9	7311.00	64.7 PK	74.0	-9.3	1.96 H	121	57.5	7.2
10	7311.00	50.9 AV	54.0	-3.1	1.96 H	121	43.7	7.2

Antenna Polarity & Test Distance : Vertical at 3 m

No	Frequency (MHz)	Emission Level (dBuV/m)	Limit (dBuV/m)	Margin (dB)	Antenna Height (m)	Table Angle (Degree)	Raw Value (dBuV)	Correction Factor (dB/m)
1	2390.00	56.1 PK	74.0	-17.9	1.30 V	147	58.8	-2.7
2	2390.00	42.6 AV	54.0	-11.4	1.30 V	147	45.3	-2.7
3	*2437.00	113.8 PK			1.30 V	147	116.5	-2.7
4	*2437.00	102.3 AV			1.30 V	147	105.0	-2.7
5	2483.50	57.3 PK	74.0	-16.7	1.30 V	147	60.1	-2.8
6	2483.50	43.2 AV	54.0	-10.8	1.30 V	147	46.0	-2.8
7	4874.00	42.8 PK	74.0	-31.2	1.49 V	132	41.1	1.7
8	4874.00	31.0 AV	54.0	-23.0	1.49 V	132	29.3	1.7
9	7311.00	58.2 PK	74.0	-15.8	3.26 V	158	51.0	7.2
10	7311.00	43.2 AV	54.0	-10.8	3.26 V	158	36.0	7.2

Remarks:

1. Emission Level(dBuV/m) = Raw Value(dBuV) + Correction Factor(dB/m)
2. Correction Factor(dB/m) = Antenna Factor(dB/m) + Cable Factor(dB) – Pre-Amplifier Factor(dB)
3. Margin value = Emission Level – Limit value
4. The other emission levels were very low against the limit.
5. " * " : Fundamental frequency.

RF Mode	TX 20MHz Preamble 802.11ax (RU52)	Channel	CH 11 : 2462 MHz
Frequency Range	1GHz ~ 25GHz	Detector Function	Peak (PK) Average (AV)

Antenna Polarity & Test Distance : Horizontal at 3 m

No	Frequency (MHz)	Emission Level (dBuV/m)	Limit (dBuV/m)	Margin (dB)	Antenna Height (m)	Table Angle (Degree)	Raw Value (dBuV)	Correction Factor (dB/m)
1	*2462.00	119.7 PK			2.49 H	127	122.5	-2.8
2	*2462.00	107.9 AV			2.49 H	127	110.7	-2.8
3	2484.10	72.2 PK	74.0	-1.8	2.49 H	127	75.0	-2.8
4	2484.10	47.0 AV	54.0	-7.0	2.49 H	127	49.8	-2.8
5	4924.00	46.1 PK	74.0	-27.9	1.80 H	181	44.3	1.8
6	4924.00	35.5 AV	54.0	-18.5	1.80 H	181	33.7	1.8
7	7386.00	63.9 PK	74.0	-10.1	1.99 H	91	56.5	7.4
8	7386.00	46.4 AV	54.0	-7.6	1.99 H	91	39.0	7.4

Antenna Polarity & Test Distance : Vertical at 3 m

No	Frequency (MHz)	Emission Level (dBuV/m)	Limit (dBuV/m)	Margin (dB)	Antenna Height (m)	Table Angle (Degree)	Raw Value (dBuV)	Correction Factor (dB/m)
1	*2462.00	111.7 PK			1.53 V	141	114.5	-2.8
2	*2462.00	100.1 AV			1.53 V	141	102.9	-2.8
3	2483.50	64.4 PK	74.0	-9.6	1.53 V	141	67.2	-2.8
4	2483.50	43.7 AV	54.0	-10.3	1.53 V	141	46.5	-2.8
5	2496.70	67.8 PK	74.0	-6.2	1.53 V	141	70.6	-2.8
6	2496.70	42.9 AV	54.0	-11.1	1.53 V	141	45.7	-2.8
7	4924.00	42.6 PK	74.0	-31.4	1.47 V	129	40.8	1.8
8	4924.00	31.2 AV	54.0	-22.8	1.47 V	129	29.4	1.8
9	7386.00	57.2 PK	74.0	-16.8	3.30 V	168	49.8	7.4
10	7386.00	42.5 AV	54.0	-11.5	3.30 V	168	35.1	7.4

Remarks:

1. Emission Level(dBuV/m) = Raw Value(dBuV) + Correction Factor(dB/m)
2. Correction Factor(dB/m) = Antenna Factor(dB/m) + Cable Factor(dB) – Pre-Amplifier Factor(dB)
3. Margin value = Emission Level – Limit value
4. The other emission levels were very low against the limit.
5. " * ": Fundamental frequency.

RF Mode	TX 20MHz Preamble 802.11ax (RU52)	Channel	CH 12 : 2467 MHz
Frequency Range	1GHz ~ 25GHz	Detector Function	Peak (PK) Average (AV)

Antenna Polarity & Test Distance : Horizontal at 3 m

No	Frequency (MHz)	Emission Level (dBuV/m)	Limit (dBuV/m)	Margin (dB)	Antenna Height (m)	Table Angle (Degree)	Raw Value (dBuV)	Correction Factor (dB/m)
1	*2467.00	118.5 PK			2.47 H	124	121.3	-2.8
2	*2467.00	106.7 AV			2.47 H	124	109.5	-2.8
3	2483.50	72.1 PK	74.0	-1.9	2.47 H	124	74.9	-2.8
4	2483.50	48.7 AV	54.0	-5.3	2.47 H	124	51.5	-2.8
5	2484.63	72.4 PK	74.0	-1.6	2.47 H	124	75.2	-2.8
6	2484.63	47.8 AV	54.0	-6.2	2.47 H	124	50.6	-2.8
7	4934.00	45.5 PK	74.0	-28.5	1.85 H	191	43.7	1.8
8	4934.00	35.0 AV	54.0	-19.0	1.85 H	191	33.2	1.8
9	7401.00	64.6 PK	74.0	-9.4	2.02 H	97	57.1	7.5
10	7401.00	47.1 AV	54.0	-6.9	2.02 H	97	39.6	7.5

Antenna Polarity & Test Distance : Vertical at 3 m

No	Frequency (MHz)	Emission Level (dBuV/m)	Limit (dBuV/m)	Margin (dB)	Antenna Height (m)	Table Angle (Degree)	Raw Value (dBuV)	Correction Factor (dB/m)
1	*2467.00	110.4 PK			1.55 V	137	113.2	-2.8
2	*2467.00	98.5 AV			1.55 V	137	101.3	-2.8
3	2484.70	65.6 PK	74.0	-8.4	1.55 V	137	68.4	-2.8
4	2484.70	44.4 AV	54.0	-9.6	1.55 V	137	47.2	-2.8
5	4934.00	42.0 PK	74.0	-32.0	1.43 V	109	40.2	1.8
6	4934.00	30.7 AV	54.0	-23.3	1.43 V	109	28.9	1.8
7	7401.00	57.8 PK	74.0	-16.2	3.32 V	163	50.3	7.5
8	7401.00	42.8 AV	54.0	-11.2	3.32 V	163	35.3	7.5

Remarks:

1. Emission Level(dBuV/m) = Raw Value(dBuV) + Correction Factor(dB/m)
2. Correction Factor(dB/m) = Antenna Factor(dB/m) + Cable Factor(dB) – Pre-Amplifier Factor(dB)
3. Margin value = Emission Level – Limit value
4. The other emission levels were very low against the limit.
5. " * ": Fundamental frequency.

RF Mode	TX 20MHz Preamble 802.11ax (RU52)	Channel	CH 13 : 2472 MHz
Frequency Range	1GHz ~ 25GHz	Detector Function	Peak (PK) Average (AV)

Antenna Polarity & Test Distance : Horizontal at 3 m

No	Frequency (MHz)	Emission Level (dBuV/m)	Limit (dBuV/m)	Margin (dB)	Antenna Height (m)	Table Angle (Degree)	Raw Value (dBuV)	Correction Factor (dB/m)
1	*2472.00	108.2 PK			1.50 H	359	111.0	-2.8
2	*2472.00	99.6 AV			1.50 H	359	102.4	-2.8
3	2483.50	72.3 PK	74.0	-1.7	1.50 H	359	75.1	-2.8
4	2483.50	49.6 AV	54.0	-4.4	1.50 H	359	52.4	-2.8
5	4944.00	46.1 PK	74.0	-27.9	1.85 H	166	44.3	1.8
6	4944.00	35.5 AV	54.0	-18.5	1.85 H	166	33.7	1.8
7	7416.00	64.2 PK	74.0	-9.8	2.03 H	116	56.7	7.5
8	7416.00	46.6 AV	54.0	-7.4	2.03 H	116	39.1	7.5

Antenna Polarity & Test Distance : Vertical at 3 m

No	Frequency (MHz)	Emission Level (dBuV/m)	Limit (dBuV/m)	Margin (dB)	Antenna Height (m)	Table Angle (Degree)	Raw Value (dBuV)	Correction Factor (dB/m)
1	*2472.00	106.5 PK			1.67 V	143	109.3	-2.8
2	*2472.00	94.8 AV			1.67 V	143	97.6	-2.8
3	2484.42	66.6 PK	74.0	-7.4	1.67 V	143	69.4	-2.8
4	2484.42	45.3 AV	54.0	-8.7	1.67 V	143	48.1	-2.8
5	4944.00	43.1 PK	74.0	-30.9	1.42 V	106	41.3	1.8
6	4944.00	31.4 AV	54.0	-22.6	1.42 V	106	29.6	1.8
7	7416.00	57.2 PK	74.0	-16.8	3.26 V	178	49.7	7.5
8	7416.00	42.7 AV	54.0	-11.3	3.26 V	178	35.2	7.5

Remarks:

1. Emission Level(dBuV/m) = Raw Value(dBuV) + Correction Factor(dB/m)
2. Correction Factor(dB/m) = Antenna Factor(dB/m) + Cable Factor(dB) – Pre-Amplifier Factor(dB)
3. Margin value = Emission Level – Limit value
4. The other emission levels were very low against the limit.
5. " * ": Fundamental frequency.

RF Mode	TX 20MHz Preamble 802.11ax (RU106)	Channel	CH 1 : 2412 MHz
Frequency Range	1GHz ~ 25GHz	Detector Function	Peak (PK) Average (AV)

Antenna Polarity & Test Distance : Horizontal at 3 m

No	Frequency (MHz)	Emission Level (dBuV/m)	Limit (dBuV/m)	Margin (dB)	Antenna Height (m)	Table Angle (Degree)	Raw Value (dBuV)	Correction Factor (dB/m)
1	2390.00	72.1 PK	74.0	-1.9	2.30 H	120	74.8	-2.7
2	2390.00	46.4 AV	54.0	-7.6	2.30 H	120	49.1	-2.7
3	*2412.00	115.7 PK			2.30 H	120	118.4	-2.7
4	*2412.00	104.4 AV			2.30 H	120	107.1	-2.7
5	4824.00	45.7 PK	74.0	-28.3	1.82 H	168	43.9	1.8
6	4824.00	35.0 AV	54.0	-19.0	1.82 H	168	33.2	1.8

Antenna Polarity & Test Distance : Vertical at 3 m

No	Frequency (MHz)	Emission Level (dBuV/m)	Limit (dBuV/m)	Margin (dB)	Antenna Height (m)	Table Angle (Degree)	Raw Value (dBuV)	Correction Factor (dB/m)
1	2390.00	68.8 PK	74.0	-5.2	1.39 V	157	71.5	-2.7
2	2390.00	44.4 AV	54.0	-9.6	1.39 V	157	47.1	-2.7
3	*2412.00	108.8 PK			1.39 V	157	111.5	-2.7
4	*2412.00	97.7 AV			1.39 V	157	100.4	-2.7
5	4824.00	42.5 PK	74.0	-31.5	1.38 V	123	40.7	1.8
6	4824.00	31.3 AV	54.0	-22.7	1.38 V	123	29.5	1.8

Remarks:

1. Emission Level(dBuV/m) = Raw Value(dBuV) + Correction Factor(dB/m)
2. Correction Factor(dB/m) = Antenna Factor(dB/m) + Cable Factor(dB) – Pre-Amplifier Factor(dB)
3. Margin value = Emission Level – Limit value
4. The other emission levels were very low against the limit.
5. " * " : Fundamental frequency.

RF Mode	TX 20MHz Preamble 802.11ax (RU106)	Channel	CH 6 : 2437 MHz
Frequency Range	1GHz ~ 25GHz	Detector Function	Peak (PK) Average (AV)

Antenna Polarity & Test Distance : Horizontal at 3 m

No	Frequency (MHz)	Emission Level (dBuV/m)	Limit (dBuV/m)	Margin (dB)	Antenna Height (m)	Table Angle (Degree)	Raw Value (dBuV)	Correction Factor (dB/m)
1	2390.00	58.2 PK	74.0	-15.8	2.28 H	105	60.9	-2.7
2	2390.00	44.2 AV	54.0	-9.8	2.28 H	105	46.9	-2.7
3	*2437.00	117.1 PK			2.28 H	105	119.8	-2.7
4	*2437.00	106.3 AV			2.28 H	105	109.0	-2.7
5	2483.50	72.3 PK	74.0	-1.7	2.28 H	105	75.1	-2.8
6	2483.50	44.9 AV	54.0	-9.1	2.28 H	105	47.7	-2.8
7	4874.00	46.2 PK	74.0	-27.8	1.78 H	174	44.5	1.7
8	4874.00	35.6 AV	54.0	-18.4	1.78 H	174	33.9	1.7
9	7311.00	61.7 PK	74.0	-12.3	1.90 H	106	54.5	7.2
10	7311.00	48.1 AV	54.0	-5.9	1.90 H	106	40.9	7.2

Antenna Polarity & Test Distance : Vertical at 3 m

No	Frequency (MHz)	Emission Level (dBuV/m)	Limit (dBuV/m)	Margin (dB)	Antenna Height (m)	Table Angle (Degree)	Raw Value (dBuV)	Correction Factor (dB/m)
1	2390.00	57.6 PK	74.0	-16.4	1.35 V	151	60.3	-2.7
2	2390.00	43.8 AV	54.0	-10.2	1.35 V	151	46.5	-2.7
3	*2437.00	110.2 PK			1.35 V	151	112.9	-2.7
4	*2437.00	99.1 AV			1.35 V	151	101.8	-2.7
5	2483.50	58.5 PK	74.0	-15.5	1.35 V	151	61.3	-2.8
6	2483.50	44.7 AV	54.0	-9.3	1.35 V	151	47.5	-2.8
7	4874.00	43.2 PK	74.0	-30.8	1.49 V	130	41.5	1.7
8	4874.00	31.4 AV	54.0	-22.6	1.49 V	130	29.7	1.7
9	7311.00	57.0 PK	74.0	-17.0	3.25 V	162	49.8	7.2
10	7311.00	42.5 AV	54.0	-11.5	3.25 V	162	35.3	7.2

Remarks:

1. Emission Level(dBuV/m) = Raw Value(dBuV) + Correction Factor(dB/m)
2. Correction Factor(dB/m) = Antenna Factor(dB/m) + Cable Factor(dB) – Pre-Amplifier Factor(dB)
3. Margin value = Emission Level – Limit value
4. The other emission levels were very low against the limit.
5. " * ": Fundamental frequency.

RF Mode	TX 20MHz Preamble 802.11ax (RU106)	Channel	CH 11 : 2462 MHz
Frequency Range	1GHz ~ 25GHz	Detector Function	Peak (PK) Average (AV)

Antenna Polarity & Test Distance : Horizontal at 3 m

No	Frequency (MHz)	Emission Level (dBuV/m)	Limit (dBuV/m)	Margin (dB)	Antenna Height (m)	Table Angle (Degree)	Raw Value (dBuV)	Correction Factor (dB/m)
1	*2462.00	116.0 PK			2.78 H	104	118.8	-2.8
2	*2462.00	104.6 AV			2.78 H	104	107.4	-2.8
3	2484.41	72.4 PK	74.0	-1.6	2.78 H	104	75.2	-2.8
4	2484.41	47.2 AV	54.0	-6.8	2.78 H	104	50.0	-2.8
5	4924.00	46.0 PK	74.0	-28.0	1.79 H	197	44.2	1.8
6	4924.00	35.1 AV	54.0	-18.9	1.79 H	197	33.3	1.8
7	7386.00	64.3 PK	74.0	-9.7	2.00 H	122	56.9	7.4
8	7386.00	46.5 AV	54.0	-7.5	2.00 H	122	39.1	7.4

Antenna Polarity & Test Distance : Vertical at 3 m

No	Frequency (MHz)	Emission Level (dBuV/m)	Limit (dBuV/m)	Margin (dB)	Antenna Height (m)	Table Angle (Degree)	Raw Value (dBuV)	Correction Factor (dB/m)
1	*2462.00	107.2 PK			1.49 V	142	110.0	-2.8
2	*2462.00	96.4 AV			1.49 V	142	99.2	-2.8
3	2483.50	66.5 PK	74.0	-7.5	1.49 V	142	69.3	-2.8
4	2483.50	45.0 AV	54.0	-9.0	1.49 V	142	47.8	-2.8
5	4924.00	42.2 PK	74.0	-31.8	1.45 V	101	40.4	1.8
6	4924.00	30.8 AV	54.0	-23.2	1.45 V	101	29.0	1.8
7	7386.00	58.1 PK	74.0	-15.9	3.28 V	153	50.7	7.4
8	7386.00	43.2 AV	54.0	-10.8	3.28 V	153	35.8	7.4

Remarks:

1. Emission Level(dBuV/m) = Raw Value(dBuV) + Correction Factor(dB/m)
2. Correction Factor(dB/m) = Antenna Factor(dB/m) + Cable Factor(dB) – Pre-Amplifier Factor(dB)
3. Margin value = Emission Level – Limit value
4. The other emission levels were very low against the limit.
5. " * ": Fundamental frequency.

RF Mode	TX 20MHz Preamble 802.11ax (RU106)	Channel	CH 12 : 2467 MHz
Frequency Range	1GHz ~ 25GHz	Detector Function	Peak (PK) Average (AV)

Antenna Polarity & Test Distance : Horizontal at 3 m

No	Frequency (MHz)	Emission Level (dBuV/m)	Limit (dBuV/m)	Margin (dB)	Antenna Height (m)	Table Angle (Degree)	Raw Value (dBuV)	Correction Factor (dB/m)
1	*2467.00	113.5 PK			2.73 H	103	116.3	-2.8
2	*2467.00	102.3 AV			2.73 H	103	105.1	-2.8
3	2483.81	72.4 PK	74.0	-1.6	2.73 H	103	75.2	-2.8
4	2483.81	48.2 AV	54.0	-5.8	2.73 H	103	51.0	-2.8
5	4934.00	45.4 PK	74.0	-28.6	1.75 H	174	43.6	1.8
6	4934.00	34.6 AV	54.0	-19.4	1.75 H	174	32.8	1.8
7	7401.00	64.5 PK	74.0	-9.5	2.04 H	101	57.0	7.5
8	7401.00	46.7 AV	54.0	-7.3	2.04 H	101	39.2	7.5

Antenna Polarity & Test Distance : Vertical at 3 m

No	Frequency (MHz)	Emission Level (dBuV/m)	Limit (dBuV/m)	Margin (dB)	Antenna Height (m)	Table Angle (Degree)	Raw Value (dBuV)	Correction Factor (dB/m)
1	*2467.00	105.3 PK			1.51 V	148	108.1	-2.8
2	*2467.00	94.3 AV			1.51 V	148	97.1	-2.8
3	2483.50	64.7 PK	74.0	-9.3	1.51 V	148	67.5	-2.8
4	2483.50	44.2 AV	54.0	-9.8	1.51 V	148	47.0	-2.8
5	4934.00	43.2 PK	74.0	-30.8	1.46 V	113	41.4	1.8
6	4934.00	31.4 AV	54.0	-22.6	1.46 V	113	29.6	1.8
7	7401.00	57.9 PK	74.0	-16.1	3.35 V	154	50.4	7.5
8	7401.00	43.2 AV	54.0	-10.8	3.35 V	154	35.7	7.5

Remarks:

1. Emission Level(dBuV/m) = Raw Value(dBuV) + Correction Factor(dB/m)
2. Correction Factor(dB/m) = Antenna Factor(dB/m) + Cable Factor(dB) – Pre-Amplifier Factor(dB)
3. Margin value = Emission Level – Limit value
4. The other emission levels were very low against the limit.
5. " * ": Fundamental frequency.

RF Mode	TX 20MHz Preamble 802.11ax (RU106)	Channel	CH 13 : 2472 MHz
Frequency Range	1GHz ~ 25GHz	Detector Function	Peak (PK) Average (AV)

Antenna Polarity & Test Distance : Horizontal at 3 m

No	Frequency (MHz)	Emission Level (dBuV/m)	Limit (dBuV/m)	Margin (dB)	Antenna Height (m)	Table Angle (Degree)	Raw Value (dBuV)	Correction Factor (dB/m)
1	*2472.00	111.2 PK			2.71 H	102	114.0	-2.8
2	*2472.00	100.1 AV			2.71 H	102	102.9	-2.8
3	2483.50	72.2 PK	74.0	-1.8	2.71 H	102	75.0	-2.8
4	2483.50	50.8 AV	54.0	-3.2	2.71 H	102	53.6	-2.8
5	4944.00	45.0 PK	74.0	-29.0	1.78 H	171	43.2	1.8
6	4944.00	34.6 AV	54.0	-19.4	1.78 H	171	32.8	1.8
7	7416.00	64.1 PK	74.0	-9.9	1.99 H	112	56.6	7.5
8	7416.00	46.4 AV	54.0	-7.6	1.99 H	112	38.9	7.5

Antenna Polarity & Test Distance : Vertical at 3 m

No	Frequency (MHz)	Emission Level (dBuV/m)	Limit (dBuV/m)	Margin (dB)	Antenna Height (m)	Table Angle (Degree)	Raw Value (dBuV)	Correction Factor (dB/m)
1	*2472.00	103.1 PK			1.56 V	136	105.9	-2.8
2	*2472.00	92.1 AV			1.56 V	136	94.9	-2.8
3	2483.50	64.1 PK	74.0	-9.9	1.56 V	136	66.9	-2.8
4	2483.50	45.7 AV	54.0	-8.3	1.56 V	136	48.5	-2.8
5	4944.00	42.9 PK	74.0	-31.1	1.40 V	124	41.1	1.8
6	4944.00	31.3 AV	54.0	-22.7	1.40 V	124	29.5	1.8
7	7416.00	58.3 PK	74.0	-15.7	3.34 V	150	50.8	7.5
8	7416.00	43.3 AV	54.0	-10.7	3.34 V	150	35.8	7.5

Remarks:

1. Emission Level(dBuV/m) = Raw Value(dBuV) + Correction Factor(dB/m)
2. Correction Factor(dB/m) = Antenna Factor(dB/m) + Cable Factor(dB) – Pre-Amplifier Factor(dB)
3. Margin value = Emission Level – Limit value
4. The other emission levels were very low against the limit.
5. " * ": Fundamental frequency.

Below 1GHz Data:

RF Mode	TX 802.11g	Channel	CH 6 : 2437 MHz
Frequency Range	9kHz ~ 1GHz	Detector Function	Quasi-Peak (QP)

Antenna Polarity & Test Distance : Horizontal at 3 m								
No	Frequency (MHz)	Emission Level (dBuV/m)	Limit (dBuV/m)	Margin (dB)	Antenna Height (m)	Table Angle (Degree)	Raw Value (dBuV)	Correction Factor (dB/m)
1	120.32	38.2 QP	43.5	-5.3	3.00 H	338	53.2	-15.0
2	166.84	35.2 QP	43.5	-8.3	2.00 H	147	48.2	-13.0
3	226.34	33.2 QP	46.0	-12.8	2.00 H	137	49.1	-15.9
4	299.85	35.3 QP	46.0	-10.7	1.50 H	74	47.6	-12.3
5	336.55	33.7 QP	46.0	-12.3	1.50 H	320	45.0	-11.3
6	575.47	27.3 QP	46.0	-18.7	1.50 H	136	33.5	-6.2

Remarks:

1. Emission Level(dBuV/m) = Raw Value(dBuV) + Correction Factor(dB/m)
2. Correction Factor(dB/m) = Antenna Factor(dB/m) + Cable Factor(dB) – Pre-Amplifier Factor(dB)
3. Margin value = Emission Level – Limit value
4. The other emission levels were very low against the limit of frequency range 30MHz~1000MHz.
5. The emission levels were very low against the limit of frequency range 9kHz~30MHz: the amplitude of spurious emissions attenuated more than 20 dB below the permissible value to be report.

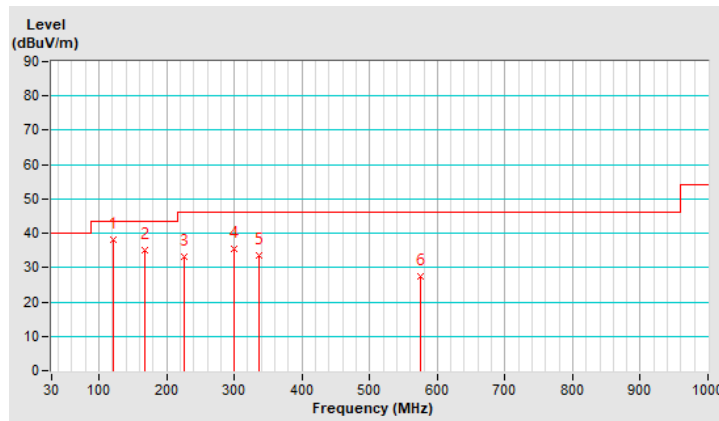

RF Mode	TX 802.11g	Channel	CH 6 : 2437 MHz
Frequency Range	9kHz ~ 1GHz	Detector Function	Quasi-Peak (QP)

Antenna Polarity & Test Distance : Vertical at 3 m								
No	Frequency (MHz)	Emission Level (dBuV/m)	Limit (dBuV/m)	Margin (dB)	Antenna Height (m)	Table Angle (Degree)	Raw Value (dBuV)	Correction Factor (dB/m)
1	126.18	29.4 QP	43.5	-14.1	1.00 V	24	43.8	-14.4
2	166.80	32.4 QP	43.5	-11.1	1.50 V	229	45.4	-13.0
3	223.77	31.5 QP	46.0	-14.5	1.00 V	138	47.5	-16.0
4	340.65	26.4 QP	46.0	-19.6	1.50 V	175	37.7	-11.3
5	498.76	24.6 QP	46.0	-21.4	1.50 V	31	32.2	-7.6
6	949.80	32.8 QP	46.0	-13.2	1.00 V	132	33.4	-0.6

Remarks:

1. Emission Level(dBuV/m) = Raw Value(dBuV) + Correction Factor(dB/m)
2. Correction Factor(dB/m) = Antenna Factor(dB/m) + Cable Factor(dB) – Pre-Amplifier Factor(dB)
3. Margin value = Emission Level – Limit value
4. The other emission levels were very low against the limit of frequency range 30MHz~1000MHz.
5. The emission levels were very low against the limit of frequency range 9kHz~30MHz: the amplitude of spurious emissions attenuated more than 20 dB below the permissible value to be report.

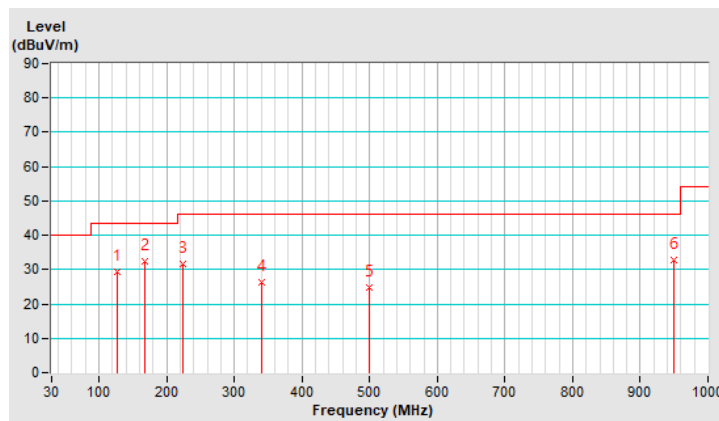

4.2 Conducted Emission Measurement

4.2.1 Limits of Conducted Emission Measurement

Frequency (MHz)	Conducted Limit (dBuV)	
	Quasi-peak	Average
0.15 - 0.5	66 - 56	56 - 46
0.50 - 5.0	56	46
5.0 - 30.0	60	50

Note: 1. The lower limit shall apply at the transition frequencies.

2. The limit decreases in line with the logarithm of the frequency in the range of 0.15 to 0.50MHz.

4.2.2 Test Instruments

DESCRIPTION & MANUFACTURER	MODEL NO.	SERIAL NO.	CALIBRATED DATE	CALIBRATED UNTIL
Test Receiver R&S	ESCS 30	847124/029	Oct. 20, 2020	Oct. 19, 2021
Line-Impedance Stabilization Network (for EUT) R&S	ESH3-Z5	848773/004	Oct. 27, 2020	Oct. 26, 2021
Line-Impedance Stabilization Network (for Peripheral) R&S	ESH3-Z5	835239/001	Mar. 26, 2021	Mar. 25, 2022
50 ohms Terminator	50	3	Oct. 26, 2020	Oct. 25, 2021
RF Cable	5D-FB	COCCAB-001	Sep. 26, 2020	Sep. 25, 2021
Fixed attenuator EMCI	STI02-2200-10	005	Aug. 29, 2020	Aug. 28, 2021
Software BVADT	BVADT_Cond_ V7.3.7.4	NA	NA	NA

1. The calibration interval of the above test instruments are 12 months and the calibrations are traceable to NML/ROC and NIST/USA.
2. The test was performed in Conduction 1.
- 3 Tested Date: June 21 to July 07, 2021

4.2.3 Test Procedures

- The EUT was placed 0.4 meters from the conducting wall of the shielded room with EUT being connected to the power mains through a line impedance stabilization network (LISN). Other support units were connected to the power mains through another LISN. The two LISNs provide 50 ohm/ 50uH of coupling impedance for the measuring instrument.
- Both lines of the power mains connected to the EUT were checked for maximum conducted interference.
- The frequency range from 150kHz to 30MHz was searched. Emission levels under (Limit - 20dB) was not recorded.

NOTE: The resolution bandwidth and video bandwidth of test receiver is 9kHz for quasi-peak detection (QP) and average detection (AV) at frequency 0.15MHz-30MHz.

4.2.4 Deviation from Test Standard

No deviation.

4.2.5 Test Setup

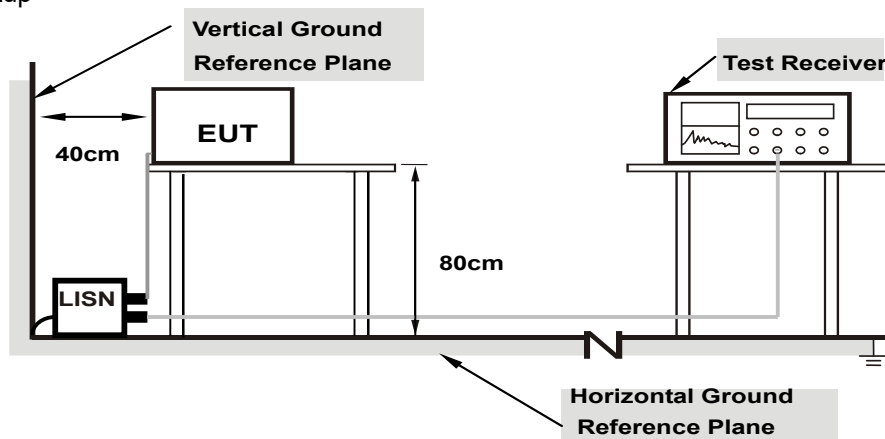

Note: 1.Support units were connected to second LISN.

For the actual test configuration, please refer to the attached file (Test Setup Photo).

4.2.6 EUT Operating Conditions

Same as 4.1.6.

4.2.7 Test Results

RF Mode	TX 802.11b	Channel	CH 6 : 2437 MHz
Frequency Range	150kHz ~ 30MHz	Detector Function & Resolution Bandwidth	Quasi-Peak (QP) / Average (AV), 9kHz

Phase Of Power : Line (L)										
No	Frequency (MHz)	Correction Factor (dB)	Reading Value (dBuV)		Emission Level (dBuV)		Limit (dBuV)		Margin (dB)	
			Q.P.	AV.	Q.P.	AV.	Q.P.	AV.	Q.P.	AV.
1	0.15781	9.95	39.14	19.49	49.09	29.44	65.58	55.58	-16.49	-26.14
2	0.16953	9.96	39.09	22.91	49.05	32.87	64.98	54.98	-15.93	-22.11
3	0.18906	9.97	32.41	14.75	42.38	24.72	64.08	54.08	-21.70	-29.36
4	0.22812	9.97	28.59	13.18	38.56	23.15	62.52	52.52	-23.96	-29.37
5	0.26328	9.98	23.78	9.30	33.76	19.28	61.33	51.33	-27.57	-32.05
6	25.87500	11.24	24.44	24.11	35.68	35.35	60.00	50.00	-24.32	-14.65

Remarks:

1. Q.P. and AV. are abbreviations of quasi-peak and average individually.
2. The emission levels of other frequencies were very low against the limit.
3. Margin value = Emission level – Limit value
4. Correction factor = Insertion loss + Cable loss
5. Emission Level = Correction Factor + Reading Value

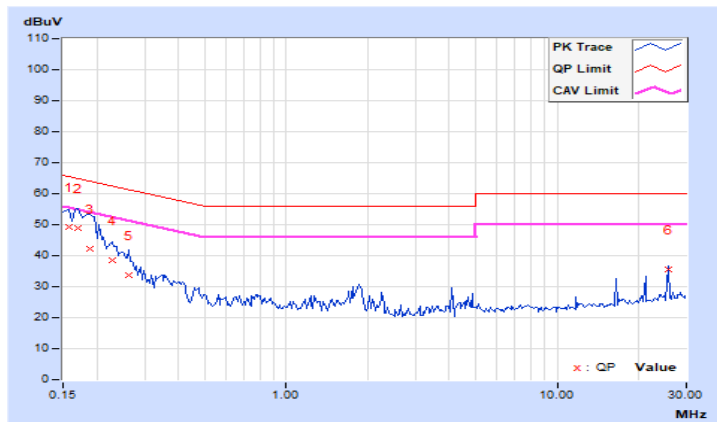

RF Mode	TX 802.11b	Channel	CH 6 : 2437 MHz
Frequency Range	150kHz ~ 30MHz	Detector Function & Resolution Bandwidth	Quasi-Peak (QP) / Average (AV), 9kHz

Phase Of Power : Neutral (N)										
No	Frequency (MHz)	Correction Factor (dB)	Reading Value (dBuV)		Emission Level (dBuV)		Limit (dBuV)		Margin (dB)	
			Q.P.	AV.	Q.P.	AV.	Q.P.	AV.	Q.P.	AV.
1	0.15000	9.92	37.13	16.16	47.05	26.08	66.00	56.00	-18.95	-29.92
2	0.17734	9.94	35.54	16.45	45.48	26.39	64.61	54.61	-19.13	-28.22
3	0.19297	9.95	37.69	21.19	47.64	31.14	63.91	53.91	-16.27	-22.77
4	0.23594	9.95	28.97	11.81	38.92	21.76	62.24	52.24	-23.32	-30.48
5	2.00781	10.04	13.26	3.02	23.30	13.06	56.00	46.00	-32.70	-32.94
6	25.87500	10.91	24.23	24.05	35.14	34.96	60.00	50.00	-24.86	-15.04

Remarks:

1. Q.P. and AV. are abbreviations of quasi-peak and average individually.
2. The emission levels of other frequencies were very low against the limit.
3. Margin value = Emission level – Limit value
4. Correction factor = Insertion loss + Cable loss
5. Emission Level = Correction Factor + Reading Value

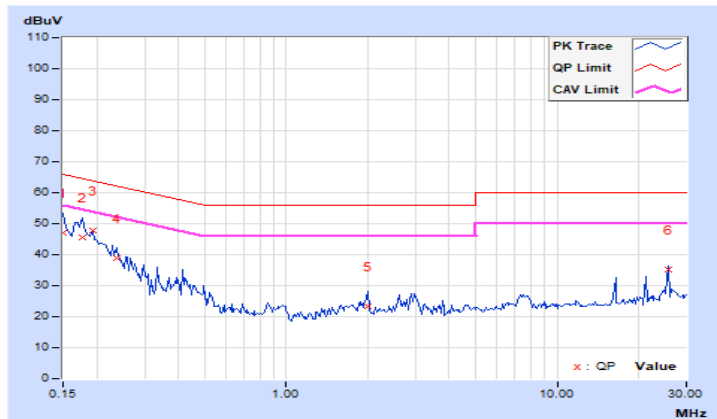

4.3 6dB Bandwidth Measurement

4.3.1 Limits of 6dB Bandwidth Measurement

The minimum of 6dB Bandwidth Measurement is 0.5 MHz.

4.3.2 Test Setup

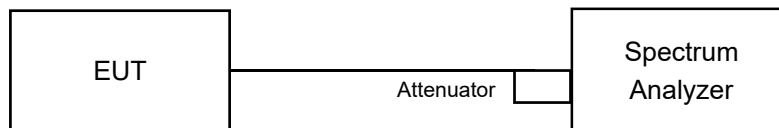

4.3.3 Test Instruments

Refer to section 4.1.2 to get information of above instrument.

4.3.4 Test Procedure

- a. Set resolution bandwidth (RBW) = 100kHz
- b. Set the video bandwidth (VBW) $\geq 3 \times$ RBW, Detector = Peak.
- c. Trace mode = max hold.
- d. Sweep = auto couple.
- e. Measure the maximum width of the emission that is constrained by the frequencies associated with the two amplitude points (upper and lower) that are attenuated by 6 dB relative to the maximum level measured in the fundamental emission

4.3.5 Deviation from Test Standard

No deviation.

4.3.6 EUT Operating Conditions

The software provided by client to enable the EUT under transmission condition continuously at lowest, middle and highest channel frequencies individually.

4.3.7 Test Result (Mode 1)

802.11b

Channel	Frequency (MHz)	6dB Bandwidth (MHz)		Minimum Limit (MHz)	Pass / Fail
		Chain 0	Chain 1		
1	2412	10.19	10.19	0.5	Pass
6	2437	10.2	11.12	0.5	Pass
11	2462	10.2	10.18	0.5	Pass
12	2467	10.19	10.18	0.5	Pass
13	2472	10.18	10.18	0.5	Pass

802.11g

Channel	Frequency (MHz)	6dB Bandwidth (MHz)		Minimum Limit (MHz)	Pass / Fail
		Chain 0	Chain 1		
1	2412	16.38	15.13	0.5	Pass
6	2437	16.36	16.35	0.5	Pass
11	2462	16.38	15.13	0.5	Pass
12	2467	16.38	15.14	0.5	Pass
13	2472	16.37	15.13	0.5	Pass

802.11ax (HE20)

Channel	Frequency (MHz)	6dB Bandwidth (MHz)		Minimum Limit (MHz)	Pass / Fail
		Chain 0	Chain 1		
1	2412	18.6	15.14	0.5	Pass
6	2437	18.55	18.75	0.5	Pass
11	2462	18.63	15.14	0.5	Pass
12	2467	18.29	15.13	0.5	Pass
13	2472	15.13	15.13	0.5	Pass

802.11ax (HE40)

Channel	Frequency (MHz)	6dB Bandwidth (MHz)		Minimum Limit (MHz)	Pass / Fail
		Chain 0	Chain 1		
3	2422	38.11	35.09	0.5	Pass
6	2437	38.11	37.97	0.5	Pass
9	2452	38.12	35.12	0.5	Pass
10	2457	35.1	35.09	0.5	Pass
11	2462	35.12	35.1	0.5	Pass

802.11ax (RU26)

RU Configuration	Channel	Frequency (MHz)	6dB Bandwidth (MHz)		Minimum Limit (MHz)	Pass / Fail
			Chain 0	Chain 1		
26/0	1	2412	14.54	14.56	0.5	Pass
26/4	6	2437	2.67	2.69	0.5	Pass
26/8	11	2462	14.57	14.52	0.5	Pass
26/8	12	2467	14.58	14.52	0.5	Pass
26/8	13	2472	14.57	14.52	0.5	Pass

802.11ax (RU52)

RU Configuration	Channel	Frequency (MHz)	6dB Bandwidth (MHz)		Minimum Limit (MHz)	Pass / Fail
			Chain 0	Chain 1		
52/37	1	2412	17.02	17.02	0.5	Pass
52/39	6	2437	9.15	9.15	0.5	Pass
52/40	11	2462	15.81	15.79	0.5	Pass
52/40	12	2467	16.99	15.78	0.5	Pass
52/40	13	2472	17	15.78	0.5	Pass

802.11ax (RU106)

RU Configuration	Channel	Frequency (MHz)	6dB Bandwidth (MHz)		Minimum Limit (MHz)	Pass / Fail
			Chain 0	Chain 1		
106/53	1	2412	16.92	16.33	0.5	Pass
106/54	6	2437	15.73	16.97	0.5	Pass
106/54	11	2462	14.85	16.7	0.5	Pass
106/54	12	2467	16.03	16.7	0.5	Pass
106/54	13	2472	16	16.71	0.5	Pass

Spectrum Plot of Worst Value

802.11b / Chain 0 : CH13

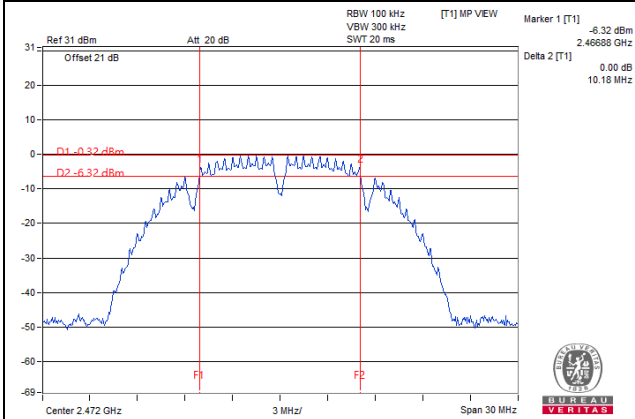

802.11g / Chain 1 : CH1

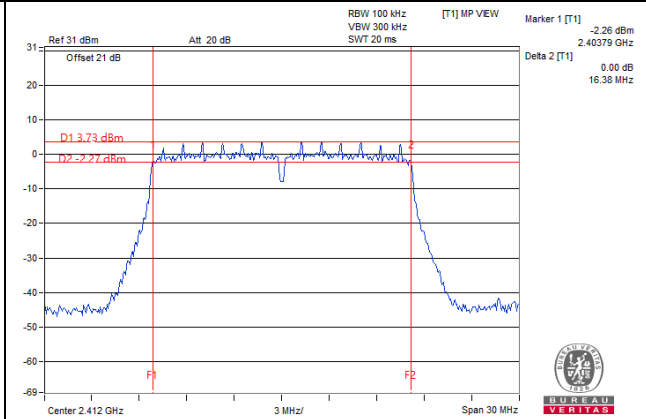

802.11ax (HE20) / Chain 0 : CH13

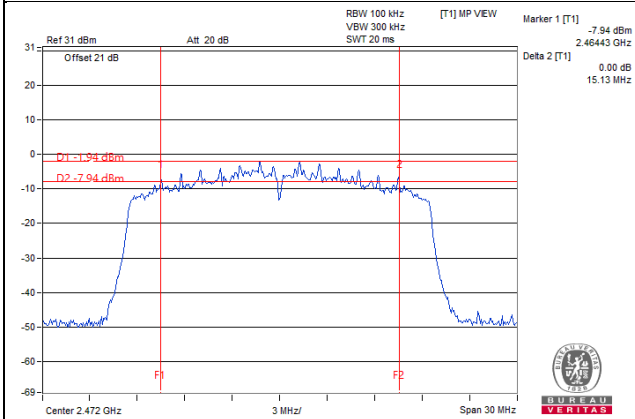

802.11ax (HE40) / Chain 1 : CH3

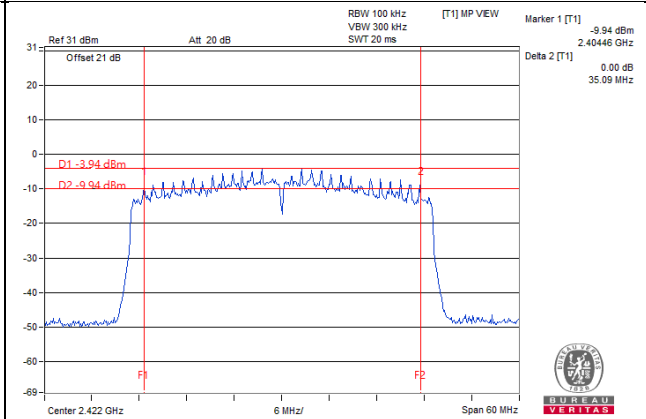

802.11ax (RU26) / Chain 0 : CH6

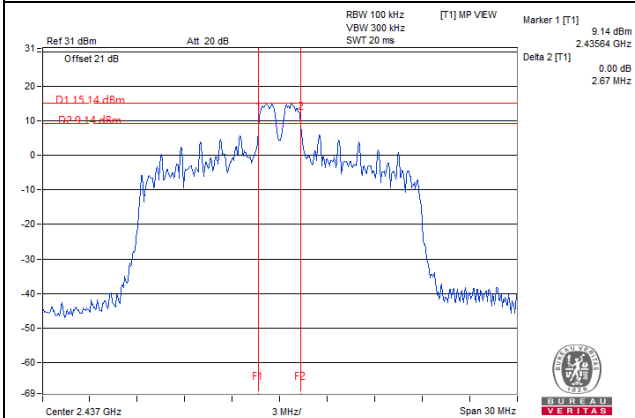

802.11ax (RU52) / Chain 0 : CH6

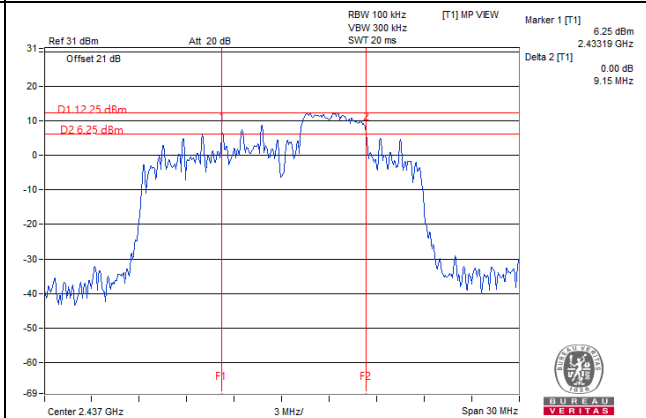

802.11ax (RU106) / Chain 0 : CH11

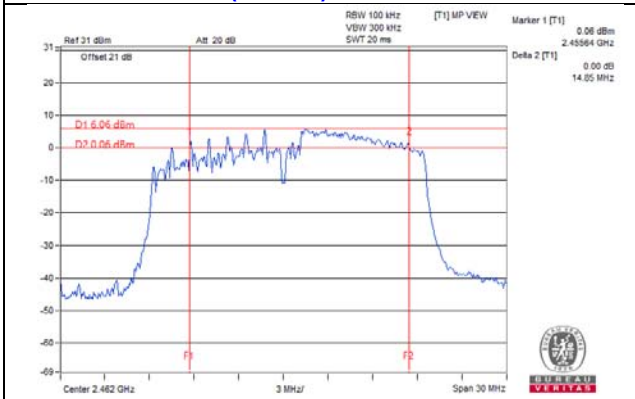

4.3.8 Test Result (Mode 2)

802.11b

Channel	Frequency (MHz)	6dB Bandwidth (MHz)	Minimum Limit (MHz)	Pass / Fail
1	2412	10.16	0.5	Pass
6	2437	10.15	0.5	Pass
11	2462	10.15	0.5	Pass
12	2467	10.16	0.5	Pass
13	2472	10.15	0.5	Pass

802.11g

Channel	Frequency (MHz)	6dB Bandwidth (MHz)	Minimum Limit (MHz)	Pass / Fail
1	2412	16.37	0.5	Pass
6	2437	16.36	0.5	Pass
11	2462	16.37	0.5	Pass
12	2467	16.37	0.5	Pass
13	2472	16.37	0.5	Pass

802.11ax (HE20)

Channel	Frequency (MHz)	6dB Bandwidth (MHz)	Minimum Limit (MHz)	Pass / Fail
1	2412	18.62	0.5	Pass
6	2437	18.99	0.5	Pass
11	2462	18.61	0.5	Pass
12	2467	18.64	0.5	Pass
13	2472	18.66	0.5	Pass

802.11ax (HE40)

Channel	Frequency (MHz)	6dB Bandwidth (MHz)	Minimum Limit (MHz)	Pass / Fail
3	2422	38.12	0.5	Pass
6	2437	38.12	0.5	Pass
9	2452	38.12	0.5	Pass
10	2457	38.12	0.5	Pass
11	2462	38.12	0.5	Pass

802.11ax (RU26)

RU Configuration	Channel	Frequency (MHz)	6dB Bandwidth (MHz)	Minimum Limit (MHz)	Pass / Fail
26/0	1	2412	14.56	0.5	Pass
26/4	6	2437	2.68	0.5	Pass
26/8	11	2462	14.51	0.5	Pass
26/8	12	2467	14.52	0.5	Pass
26/8	13	2472	14.52	0.5	Pass

802.11ax (RU52)

RU Configuration	Channel	Frequency (MHz)	6dB Bandwidth (MHz)	Minimum Limit (MHz)	Pass / Fail
52/37	1	2412	17.05	0.5	Pass
52/39	6	2437	9.16	0.5	Pass
52/40	11	2462	15.8	0.5	Pass
52/40	12	2467	15.81	0.5	Pass
52/40	13	2472	15.8	0.5	Pass

802.11ax (RU106)

RU Configuration	Channel	Frequency (MHz)	6dB Bandwidth (MHz)	Minimum Limit (MHz)	Pass / Fail
106/53	1	2412	16.93	0.5	Pass
106/54	6	2437	14.84	0.5	Pass
106/54	11	2462	14.85	0.5	Pass
106/54	12	2467	16.03	0.5	Pass
106/54	13	2472	16.01	0.5	Pass

Spectrum Plot of Worst Value

802.11b / CH6

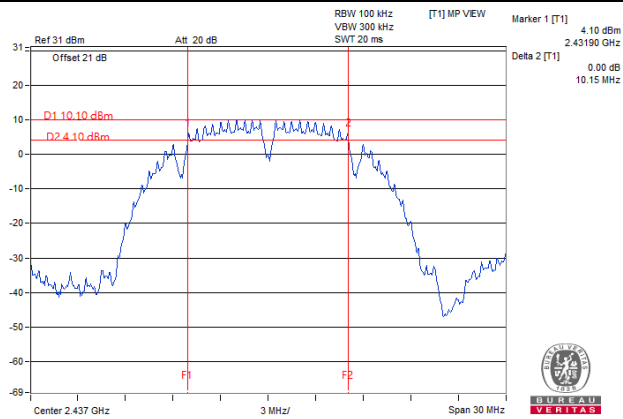

802.11g / CH6

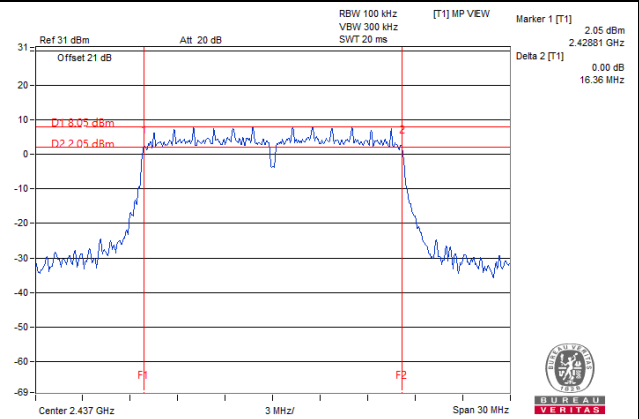

802.11ax (HE20) / CH11

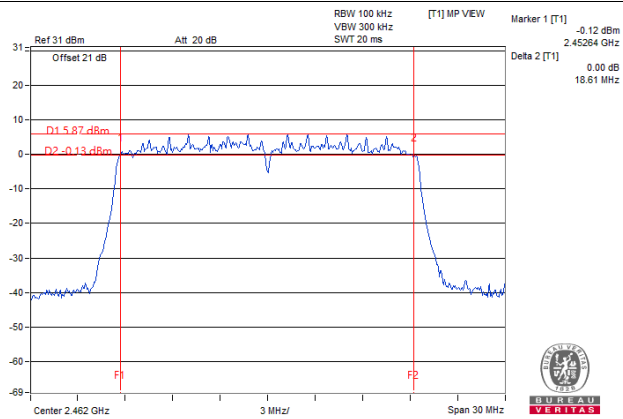

802.11ax (HE40) / CH6

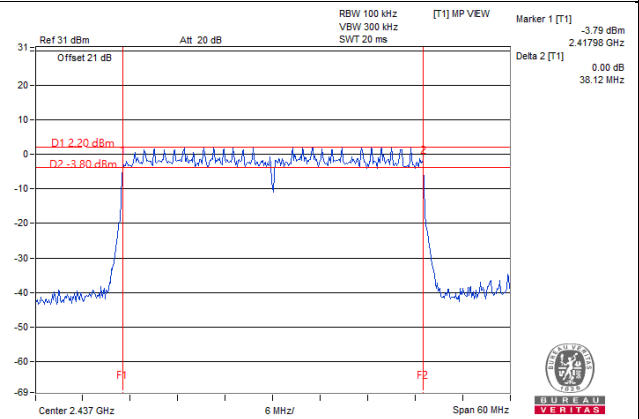

802.11ax (RU26) / CH6

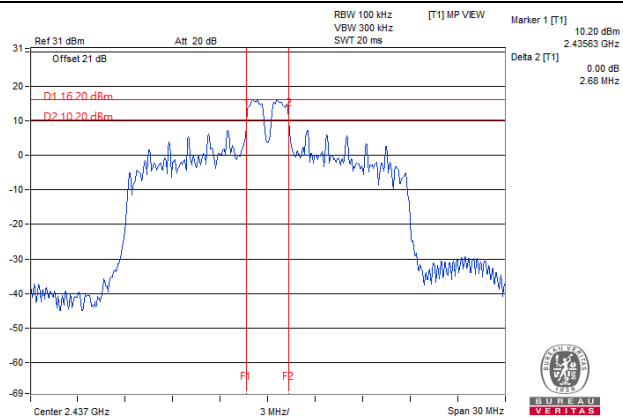

802.11ax (RU52) / CH6

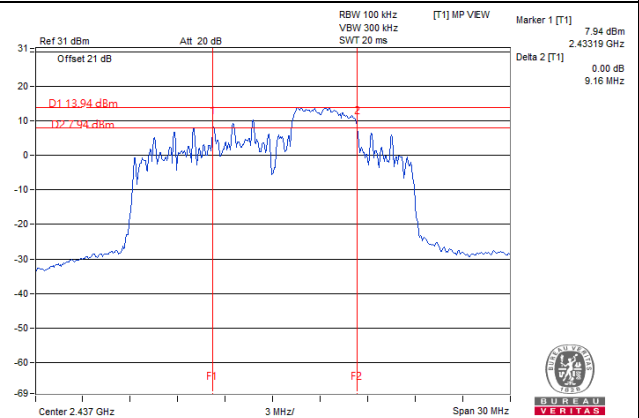

802.11ax (RU106) / CH6

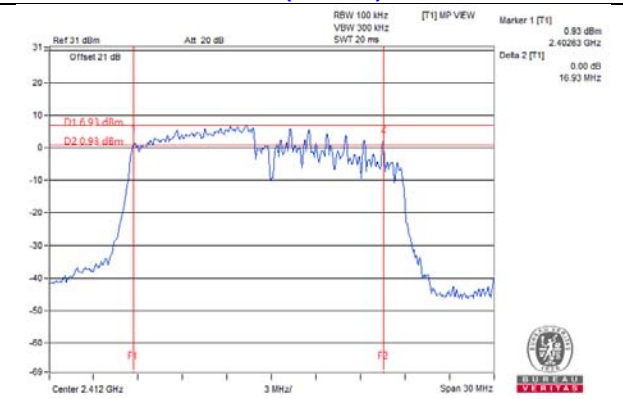

4.4 Conducted Output Power Measurement

4.4.1 Limits of Conducted Output Power Measurement

For systems using digital modulation in the 2400–2483.5 MHz bands: 1 Watt (30dBm)

Per KDB 662911 D01 Multiple Transmitter Output Method of conducted output power measurement on IEEE 802.11 devices,

Array Gain = 0 dB (i.e., no array gain) for $N_{ANT} \leq 4$;

Array Gain = 0 dB (i.e., no array gain) for channel widths ≥ 40 MHz for any N_{ANT} ;

Array Gain = $5 \log(N_{ANT}/N_{SS})$ dB or 3 dB, whichever is less for 20-MHz channel widths with $N_{ANT} \geq 5$.

For power measurements on all other devices: Array Gain = $10 \log(N_{ANT}/N_{SS})$ dB.

4.4.2 Test Setup

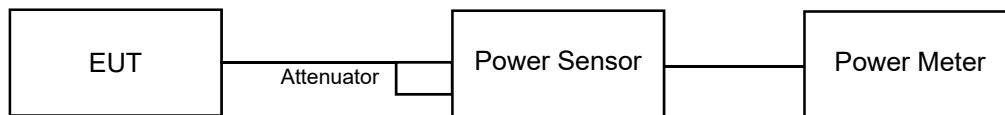

4.4.3 Test Instruments

Refer to section 4.1.2 to get information of above instrument.

4.4.4 Test Procedures

Average power sensor was used to perform output power measurement, trigger and gating function of wide band power meter is enabled to measure max output power of TX on burst. Duty factor is not added to measured value.

4.4.5 Deviation from Test Standard

No deviation.

4.4.6 EUT Operating Conditions

Same as Item 4.3.6.

4.4.7 Test Results (Mode 1)

CDD Mode

802.11b

Chan.	Chan. Freq. (MHz)	Average Power (dBm)		Total Power (mW)	Total Power (dBm)	Limit (dBm)	Pass / Fail
		Chain 0	Chain 1				
1	2412	19.81	20.05	196.877	22.94	30.00	Pass
6	2437	19.87	20.03	197.744	22.96	30.00	Pass
11	2462	19.73	20.12	196.774	22.94	30.00	Pass
12	2467	15.08	15.26	65.784	18.18	30.00	Pass
13	2472	11.81	11.94	30.802	14.89	30.00	Pass

802.11g

Chan.	Chan. Freq. (MHz)	Average Power (dBm)		Total Power (mW)	Total Power (dBm)	Limit (dBm)	Pass / Fail
		Chain 0	Chain 1				
1	2412	16.74	16.93	96.524	19.85	30.00	Pass
6	2437	21.79	21.95	307.683	24.88	30.00	Pass
11	2462	16.86	17.10	99.815	19.99	30.00	Pass
12	2467	12.86	13.05	39.503	15.97	30.00	Pass
13	2472	11.80	12.15	31.542	14.99	30.00	Pass

VHT20

Chan.	Chan. Freq. (MHz)	Average Power (dBm)		Total Power (mW)	Total Power (dBm)	Limit (dBm)	Pass / Fail
		Chain 0	Chain 1				
1	2412	15.62	15.95	75.83	18.80	30.00	Pass
6	2437	21.48	21.77	290.919	24.64	30.00	Pass
11	2462	15.71	15.97	76.776	18.85	30.00	Pass
12	2467	12.69	13.04	38.715	15.88	30.00	Pass
13	2472	11.61	11.81	29.658	14.72	30.00	Pass

VHT40

Chan.	Chan. Freq. (MHz)	Average Power (dBm)		Total Power (mW)	Total Power (dBm)	Limit (dBm)	Pass / Fail
		Chain 0	Chain 1				
3	2422	14.44	14.93	58.914	17.70	30.00	Pass
6	2437	17.67	17.93	120.566	20.81	30.00	Pass
9	2452	14.63	14.95	60.301	17.80	30.00	Pass
10	2457	11.74	12.08	31.072	14.92	30.00	Pass
11	2462	10.59	10.97	23.958	13.79	30.00	Pass

802.11ax (HE20)

Chan.	Chan. Freq. (MHz)	Average Power (dBm)		Total Power (mW)	Total Power (dBm)	Limit (dBm)	Pass / Fail
		Chain 0	Chain 1				
1	2412	15.77	16.14	78.872	18.97	30.00	Pass
6	2437	21.65	21.99	304.343	24.83	30.00	Pass
11	2462	15.88	16.16	80.031	19.03	30.00	Pass
12	2467	12.93	13.19	40.479	16.07	30.00	Pass
13	2472	11.80	12.04	31.131	14.93	30.00	Pass

802.11ax (HE40)

Chan.	Chan. Freq. (MHz)	Average Power (dBm)		Total Power (mW)	Total Power (dBm)	Limit (dBm)	Pass / Fail
		Chain 0	Chain 1				
3	2422	14.63	15.10	61.4	17.88	30.00	Pass
6	2437	17.87	18.12	126.098	21.01	30.00	Pass
9	2452	14.82	15.12	62.848	17.98	30.00	Pass
10	2457	11.96	12.24	32.453	15.11	30.00	Pass
11	2462	10.82	11.13	25.05	13.99	30.00	Pass

802.11ax (RU26)

RU Configuration	Channel	Frequency (MHz)	Average Power (dBm)		Total Power (mW)	Total Power (dBm)	Limit (dBm)	Pass / Fail
			Chain 0	Chain 1				
26/0	1	2412	16.44	16.57	89.45	19.52	30.00	Pass
26/4	6	2437	19.89	19.24	181.445	22.59	30.00	Pass
26/8	11	2462	16.31	16.36	86.008	19.35	30.00	Pass
26/8	12	2467	13.91	14.07	50.131	17.00	30.00	Pass
26/8	13	2472	9.13	8.81	15.788	11.98	30.00	Pass

802.11ax (RU52)

RU Configuration	Channel	Frequency (MHz)	Average Power (dBm)		Total Power (mW)	Total Power (dBm)	Limit (dBm)	Pass / Fail
			Chain 0	Chain 1				
52/37	1	2412	17.85	18.01	124.195	20.94	30.00	Pass
52/39	6	2437	20.07	19.89	199.124	22.99	30.00	Pass
52/40	11	2462	17.82	18.14	125.697	20.99	30.00	Pass
52/40	12	2467	12.85	13.25	40.41	16.06	30.00	Pass
52/40	13	2472	8.99	9.21	16.262	12.11	30.00	Pass

802.11ax (RU106)

RU Configuration	Channel	Frequency (MHz)	Average Power (dBm)		Total Power (mW)	Total Power (dBm)	Limit (dBm)	Pass / Fail
			Chain 0	Chain 1				
106/53	1	2412	18.64	18.85	149.85	21.76	30.00	Pass
106/54	6	2437	21.18	21.08	259.453	24.14	30.00	Pass
106/54	11	2462	18.77	18.82	151.543	21.81	30.00	Pass
106/54	12	2467	16.28	16.35	85.614	19.33	30.00	Pass
106/54	13	2472	11.90	12.08	31.632	15.00	30.00	Pass

Beamforming Mode

VHT20

Chan.	Chan. Freq. (MHz)	Average Power (dBm)		Total Power (mW)	Total Power (dBm)	Limit (dBm)	Pass / Fail
		Chain 0	Chain 1				
1	2412	15.62	15.95	75.83	18.80	29.49	Pass
6	2437	21.48	21.77	290.919	24.64	29.49	Pass
11	2462	15.71	15.97	76.776	18.85	29.49	Pass
12	2467	12.69	13.04	38.715	15.88	29.49	Pass
13	2472	11.61	11.81	29.658	14.72	29.49	Pass

Note: Directional gain = 3.5 dBi + 10 log(2) = 6.51dBi > 6dBi , so the power limit shall be reduced to 30-(6.51-6) = 29.49dBm.

VHT40

Chan.	Chan. Freq. (MHz)	Average Power (dBm)		Total Power (mW)	Total Power (dBm)	Limit (dBm)	Pass / Fail
		Chain 0	Chain 1				
3	2422	14.44	14.93	58.914	17.70	29.49	Pass
6	2437	17.67	17.93	120.566	20.81	29.49	Pass
9	2452	14.63	14.95	60.301	17.80	29.49	Pass
10	2457	11.74	12.08	31.072	14.92	29.49	Pass
11	2462	10.59	10.97	23.958	13.79	29.49	Pass

Note: Directional gain = 3.5 dBi + 10 log(2) = 6.51dBi > 6dBi , so the power limit shall be reduced to 30-(6.51-6) = 29.49dBm.

802.11ax (HE20)

Chan.	Chan. Freq. (MHz)	Average Power (dBm)		Total Power (mW)	Total Power (dBm)	Limit (dBm)	Pass / Fail
		Chain 0	Chain 1				
1	2412	15.77	16.14	78.872	18.97	29.49	Pass
6	2437	21.65	21.99	304.343	24.83	29.49	Pass
11	2462	15.88	16.16	80.031	19.03	29.49	Pass
12	2467	12.93	13.19	40.479	16.07	29.49	Pass
13	2472	11.80	12.04	31.131	14.93	29.49	Pass

Note: Directional gain = 3.5 dBi + 10 log(2) = 6.51dBi > 6dBi , so the power limit shall be reduced to 30-(6.51-6) = 29.49dBm.

802.11ax (HE40)

Chan.	Chan. Freq. (MHz)	Average Power (dBm)		Total Power (mW)	Total Power (dBm)	Limit (dBm)	Pass / Fail
		Chain 0	Chain 1				
3	2422	14.63	15.10	61.4	17.88	29.49	Pass
6	2437	17.87	18.12	126.098	21.01	29.49	Pass
9	2452	14.82	15.12	62.848	17.98	29.49	Pass
10	2457	11.96	12.24	32.453	15.11	29.49	Pass
11	2462	10.82	11.13	25.05	13.99	29.49	Pass

Note: Directional gain = 3.5 dBi + 10 log(2) = 6.51dBi > 6dBi , so the power limit shall be reduced to 30-(6.51-6) = 29.49dBm.

4.4.8 Test Results (Mode 2)

802.11b

Chan.	Chan. Freq. (MHz)	Average Power (mW)	Average Power (dBm)	Limit (dBm)	Pass / Fail
1	2412	171.396	22.34	30	Pass
6	2437	168.655	22.27	30	Pass
11	2462	165.959	22.20	30	Pass
12	2467	81.283	19.10	30	Pass
13	2472	34.834	15.42	30	Pass

802.11g

Chan.	Chan. Freq. (MHz)	Average Power (mW)	Average Power (dBm)	Limit (dBm)	Pass / Fail
1	2412	109.144	20.38	30	Pass
6	2437	175.792	22.45	30	Pass
11	2462	102.329	20.10	30	Pass
12	2467	32.509	15.12	30	Pass
13	2472	25.351	14.04	30	Pass

VHT20

Chan.	Chan. Freq. (MHz)	Average Power (mW)	Average Power (dBm)	Limit (dBm)	Pass / Fail
1	2412	108.393	20.35	30	Pass
6	2437	148.594	21.72	30	Pass
11	2462	90.573	19.57	30	Pass
12	2467	30.903	14.90	30	Pass
13	2472	24.717	13.93	30	Pass

VHT40

Chan.	Chan. Freq. (MHz)	Average Power (mW)	Average Power (dBm)	Limit (dBm)	Pass / Fail
3	2422	79.983	19.03	30	Pass
6	2437	87.902	19.44	30	Pass
9	2452	67.608	18.30	30	Pass
10	2457	66.988	18.26	30	Pass
11	2462	59.979	17.78	30	Pass

802.11ax (HE20)

Chan.	Chan. Freq. (MHz)	Average Power (mW)	Average Power (dBm)	Limit (dBm)	Pass / Fail
1	2412	110.662	20.44	30	Pass
6	2437	157.036	21.96	30	Pass
11	2462	92.257	19.65	30	Pass
12	2467	32.211	15.08	30	Pass
13	2472	25.763	14.11	30	Pass

802.11ax (HE40)

Chan.	Chan. Freq. (MHz)	Average Power (mW)	Average Power (dBm)	Limit (dBm)	Pass / Fail
3	2422	81.283	19.10	30	Pass
6	2437	89.125	19.50	30	Pass
9	2452	71.779	18.56	30	Pass
10	2457	67.608	18.30	30	Pass
11	2462	60.814	17.84	30	Pass

802.11ax (RU26)

RU Configuration	Channel	Frequency (MHz)	Average Power (mW)	Average Power (dBm)	Limit (dBm)	Pass / Fail
26/0	1	2412	68.234	18.34	30.00	Pass
26/4	6	2437	172.187	22.36	30.00	Pass
26/8	11	2462	62.087	17.93	30.00	Pass
26/8	12	2467	32.063	15.06	30.00	Pass
26/8	13	2472	8.831	9.46	30.00	Pass

802.11ax (RU52)

RU Configuration	Channel	Frequency (MHz)	Average Power (mW)	Average Power (dBm)	Limit (dBm)	Pass / Fail
52/37	1	2412	120.226	20.80	30.00	Pass
52/39	6	2437	174.985	22.43	30.00	Pass
52/40	11	2462	98.401	19.93	30.00	Pass
52/40	12	2467	86.298	19.36	30.00	Pass
52/40	13	2472	12.162	10.85	30.00	Pass

802.11ax (RU106)

RU Configuration	Channel	Frequency (MHz)	Average Power (mW)	Average Power (dBm)	Limit (dBm)	Pass / Fail
106/53	1	2412	112.72	20.52	30.00	Pass
106/54	6	2437	165.959	22.20	30.00	Pass
106/54	11	2462	94.624	19.76	30.00	Pass
106/54	12	2467	60.674	17.83	30.00	Pass
106/54	13	2472	33.806	15.29	30.00	Pass

4.5 Power Spectral Density Measurement

4.5.1 Limits of Power Spectral Density Measurement

The Maximum of Power Spectral Density Measurement is 8dBm in any 3 kHz.

4.5.2 Test Setup

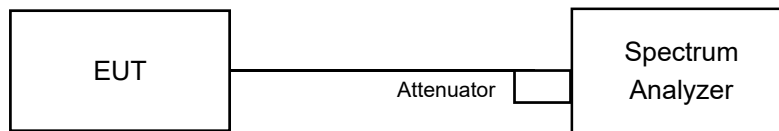

4.5.3 Test Instruments

Refer to section 4.1.2 to get information of above instrument.

4.5.4 Test Procedure

- a) Set instrument center frequency to DTS channel center frequency.
- b) Set span to at least 1.5 times the OBW.
- c) Set RBW to: $3 \text{ kHz} \leq \text{RBW} \leq 100 \text{ kHz}$.
- d) Set VBW $\geq 3 \times \text{RBW}$.
- e) Detector = power averaging (RMS) or sample detector (when RMS not available).
- f) Ensure that the number of measurement points in the sweep $\geq 2 \times \text{span}/\text{RBW}$.
- g) Sweep time = auto couple.
- h) Employ trace averaging (RMS) mode over a minimum of 100 traces.
- i) Use the peak marker function to determine the maximum amplitude level.

4.5.5 Deviation from Test Standard

No deviation.

4.5.6 EUT Operating Condition

Same as Item 4.3.6

4.5.7 Test Results (Mode 1)

802.11b

Chan.	Chan. Freq. (MHz)	PSD (dBm/3kHz)		Total PSD (mW/3kHz)	Total PSD (dBm/3kHz)	PSD Limit (dBm/3kHz)	Pass / Fail
		Chain 0	Chain 1				
1	2412	-15.54	-16.88	0.04844	-13.15	7.49	PASS
6	2437	-15.99	-16.98	0.04522	-13.45	7.49	PASS
11	2462	-16.20	-16.36	0.04711	-13.27	7.49	PASS
12	2467	-19.75	-21.15	0.018266	-17.38	7.49	PASS
13	2472	-23.42	-24.42	0.008164	-20.88	7.49	PASS

- Note:**
1. Method b) Measure and sum spectral maxima across the outputs of KDB 662911 is using for calculating total power density.
 2. Directional gain = 3.5 dBi + 10log(2) = 6.51 dBi, so the power density limit shall be reduced to 8-(6.51-6) = 7.49dBm.

802.11g

Chan.	Chan. Freq. (MHz)	PSD w/o Duty Factor (dBm/3kHz)		Total PSD (mW/3kHz)	Total PSD (dBm/3kHz)	PSD Limit (dBm/3kHz)	Pass / Fail
		Chain 0	Chain 1				
1	2412	-18.15	-19.72	0.02598	-15.85	7.49	PASS
6	2437	-13.69	-14.14	0.0813	-10.90	7.49	PASS
11	2462	-18.37	-20.04	0.024463	-16.11	7.49	PASS
12	2467	-21.75	-23.58	0.011069	-19.56	7.49	PASS
13	2472	-23.06	-25.00	0.008105	-20.91	7.49	PASS

- Note:**
1. Method b) Measure and sum spectral maxima across the outputs of KDB 662911 is using for calculating total power density.
 2. Directional gain = 3.5 dBi + 10log(2) = 6.51 dBi, so the power density limit shall be reduced to 8-(6.51-6) = 7.49dBm.

802.11ax (HE20)

Chan.	Chan. Freq. (MHz)	PSD w/o Duty Factor (dBm/3kHz)		Total PSD (mW/3kHz)	Total PSD (dBm/3kHz)	PSD Limit (dBm/3kHz)	Pass / Fail
		Chain 0	Chain 1				
1	2412	-19.14	-21.87	0.018691	-17.28	7.49	PASS
6	2437	-13.34	-15.16	0.07682	-11.15	7.49	PASS
11	2462	-19.44	-21.86	0.017893	-17.47	7.49	PASS
12	2467	-21.86	-24.40	0.010147	-19.94	7.49	PASS
13	2472	-24.17	-25.32	0.006766	-21.70	7.49	PASS

- Note:**
- Method b) Measure and sum spectral maxima across the outputs of KDB 662911 is using for calculating total power density.
 - Directional gain = 3.5 dBi + 10log(2) = 6.51 dBi, so the power density limit shall be reduced to 8-(6.51-6) = 7.49dBm.

802.11ax (HE40)

Chan.	Chan. Freq. (MHz)	PSD w/o Duty Factor (dBm/3kHz)		Total PSD (mW/3kHz)	Total PSD (dBm/3kHz)	PSD Limit (dBm/3kHz)	Pass / Fail
		Chain 0	Chain 1				
3	2422	-23.32	-25.48	0.007487	-21.26	7.49	PASS
6	2437	-19.82	-21.80	0.01703	-17.69	7.49	PASS
9	2452	-23.02	-25.96	0.007524	-21.24	7.49	PASS
10	2457	-27.01	-28.48	0.00341	-24.67	7.49	PASS
11	2462	-27.81	-29.63	0.002745	-25.61	7.49	PASS

- Note:**
- Method b) Measure and sum spectral maxima across the outputs of KDB 662911 is using for calculating total power density.
 - Directional gain = 3.5 dBi + 10log(2) = 6.51 dBi, so the power density limit shall be reduced to 8-(6.51-6) = 7.49dBm.

802.11ax (RU26)

RU Configuration	Chan.	Chan. Freq. (MHz)	PSD (dBm/3kHz)		Total PSD (mW/3kHz)	Total PSD (dBm/3kHz)	PSD Limit (dBm/3kHz)	Pass / Fail
			Chain0	Chain1				
26/0	1	2412	-9.63	-9.58	0.219	-6.60	7.49	PASS
26/4	6	2437	-7.53	-7.53	0.3532	-4.52	7.49	PASS
26/8	11	2462	-9.55	-9.75	0.2168	-6.64	7.49	PASS
26/8	12	2467	-12.28	-12.00	0.12225	-9.13	7.49	PASS
26/8	13	2472	-17.34	-17.16	0.03768	-14.24	7.49	PASS

- Note:**
- Method b) Measure and sum spectral maxima across the outputs of KDB 662911 is using for calculating total power density.
 - Directional gain = 3.5 dBi + 10log(2) = 6.51 dBi, so the power density limit shall be reduced to 8-(6.51-6) = 7.49dBm.

802.11ax (RU52)

RU Configuration	Chan.	Chan. Freq. (MHz)	PSD (dBm/3kHz)		Total PSD (mW/3kHz)	Total PSD (dBm/3kHz)	PSD Limit (dBm/3kHz)	Pass / Fail
			Chain0	Chain1				
52/37	1	2412	-9.41	-9.19	0.2351	-6.29	7.49	PASS
52/39	6	2437	-9.19	-8.28	0.2691	-5.70	7.49	PASS
52/40	11	2462	-9.42	-9.19	0.2348	-6.29	7.49	PASS
52/40	12	2467	-14.91	-14.18	0.07048	-11.52	7.49	PASS
52/40	13	2472	-18.67	-17.88	0.02988	-15.25	7.49	PASS

- Note:**
- Method b) Measure and sum spectral maxima across the outputs of KDB 662911 is using for calculating total power density.
 - Directional gain = 3.5 dBi + 10log(2) = 6.51 dBi, so the power density limit shall be reduced to 8-(6.51-6) = 7.49dBm.

802.11ax (RU106)

RU Configuration	Chan.	Chan. Freq. (MHz)	PSD (dBm/3kHz)		Total PSD (mW/3kHz)	Total PSD (dBm/3kHz)	PSD Limit (dBm/3kHz)	Pass / Fail
			Chain0	Chain1				
106/53	1	2412	-10.80	-9.90	0.18551	-7.32	7.49	PASS
106/54	6	2437	-9.19	-8.75	0.2539	-5.95	7.49	PASS
106/54	11	2462	-9.02	-8.59	0.2637	-5.79	7.49	PASS
106/54	12	2467	-10.89	-12.40	0.13901	-8.57	7.49	PASS
106/54	13	2472	-17.11	-17.03	0.03927	-14.06	7.49	PASS

- Note:**
1. Method b) Measure and sum spectral maxima across the outputs of KDB 662911 is using for calculating total power density.
 2. Directional gain = 3.5 dBi + 10log(2) = 6.51 dBi, so the power density limit shall be reduced to 8-(6.51-6) = 7.49dBm.

Spectrum Plot of Worst Value

802.11b / Chain 0: CH1

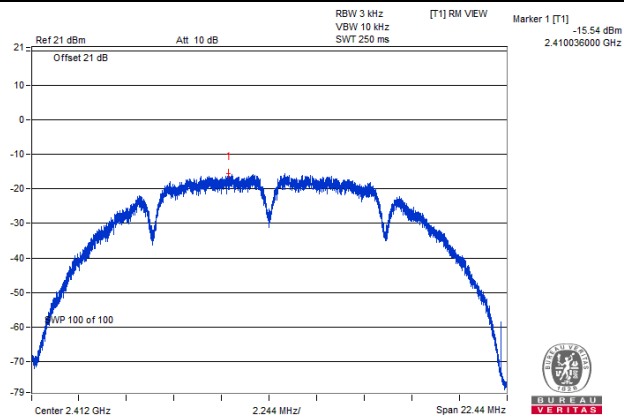

802.11g / Chain 0 : CH6

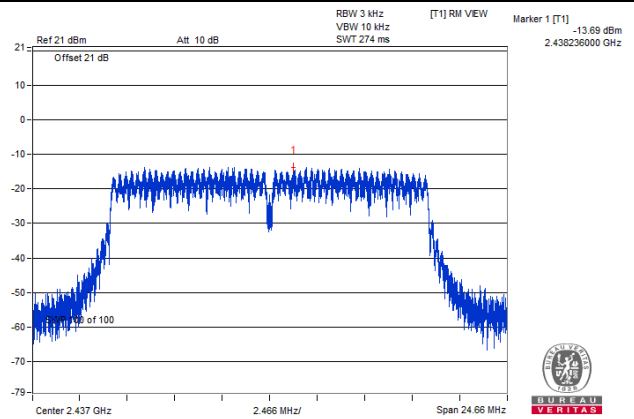

802.11ax (HE20) / Chain 0: CH6

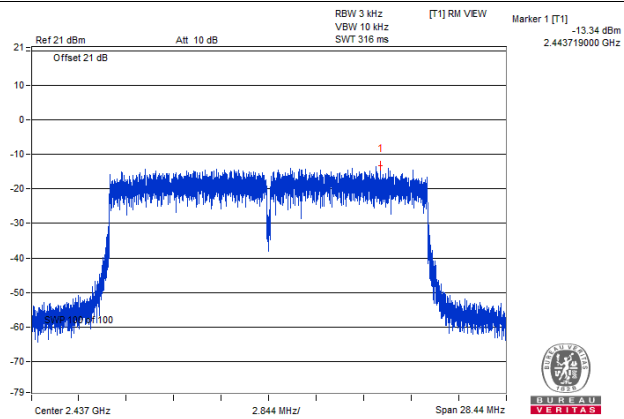

802.11ax (HE40) / Chain 0: CH6

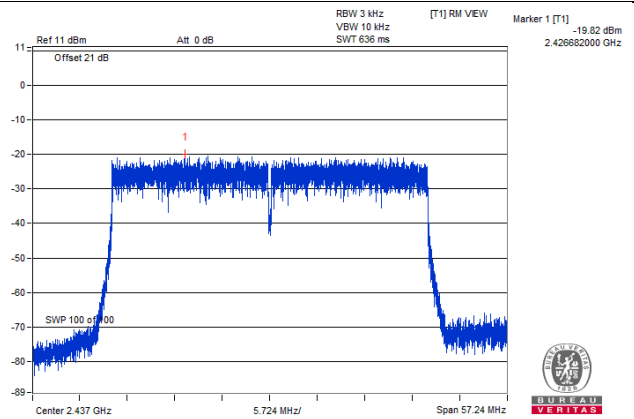

802.11ax (RU26) / Chain 0: CH6

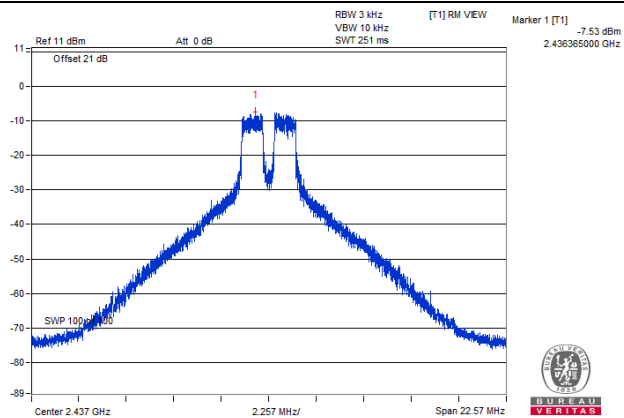

802.11ax (RU52) / Chain 1: CH6

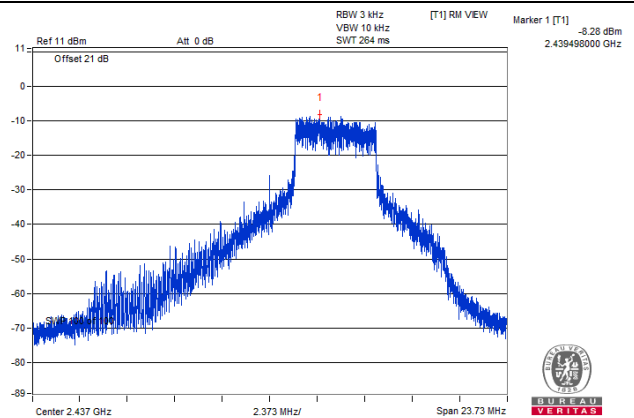

802.11ax (RU106) / Chain 1: CH11

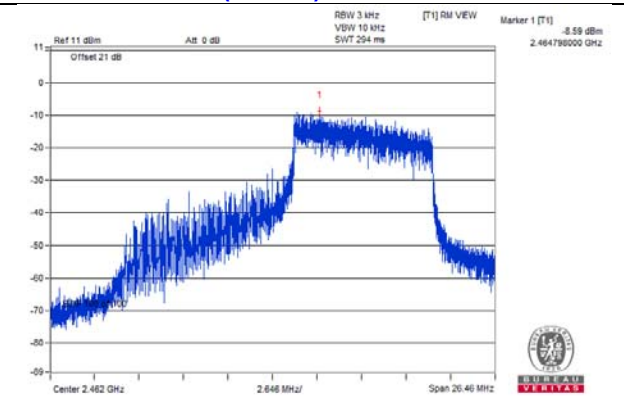

4.5.8 Test Results (Mode 2)

802.11b

Channel	Frequency (MHz)	PSD (dBm/3kHz)	Limit (dBm/3kHz)	Pass /Fail
1	2412	-12.68	8	Pass
6	2437	-13.63	8	Pass
11	2462	-12.88	8	Pass
12	2467	-15.93	8	Pass
13	2472	-18.47	8	Pass

802.11g

Channel	Frequency (MHz)	PSD (dBm/3kHz)	Limit (dBm/3kHz)	Pass /Fail
1	2412	-14.60	8	Pass
6	2437	-13.90	8	Pass
11	2462	-15.29	8	Pass
12	2467	-20.29	8	Pass
13	2472	-21.45	8	Pass

802.11ax (HE20)

Channel	Frequency (MHz)	PSD (dBm/3kHz)	Limit (dBm/3kHz)	Pass /Fail
1	2412	-14.06	8	Pass
6	2437	-13.77	8	Pass
11	2462	-15.71	8	Pass
12	2467	-20.75	8	Pass
13	2472	-21.67	8	Pass

802.11ax (HE40)

Channel	Frequency (MHz)	PSD (dBm/3kHz)	Limit (dBm/3kHz)	Pass /Fail
3	2422	-18.88	8	Pass
6	2437	-18.33	8	Pass
9	2452	-19.72	8	Pass
10	2457	-20.19	8	Pass
11	2462	-19.75	8	Pass

802.11ax (RU26)

RU Configuration	Channel	Frequency (MHz)	PSD (dBm/3kHz)	Limit (dBm/3kHz)	Pass /Fail
26/0	1	2412	-8.47	8	Pass
26/4	6	2437	-5.61	8	Pass
26/8	11	2462	-8.43	8	Pass
26/8	12	2467	-11.31	8	Pass
26/8	13	2472	-16.08	8	Pass

802.11ax (RU52)

RU Configuration	Channel	Frequency (MHz)	PSD (dBm/3kHz)	Limit (dBm/3kHz)	Pass /Fail
52/37	1	2412	-7.46	8	Pass
52/39	6	2437	-6.01	8	Pass
52/40	11	2462	-7.69	8	Pass
52/40	12	2467	-8.40	8	Pass
52/40	13	2472	-17.81	8	Pass

802.11ax (RU106)

RU Configuration	Channel	Frequency (MHz)	PSD (dBm/3kHz)	Limit (dBm/3kHz)	Pass /Fail
106/53	1	2412	-8.45	8	Pass
106/54	6	2437	-7.37	8	Pass
106/54	11	2462	-9.40	8	Pass
106/54	12	2467	-11.07	8	Pass
106/54	13	2472	-13.23	8	Pass

Spectrum Plot of Worst Value

802.11b / CH1

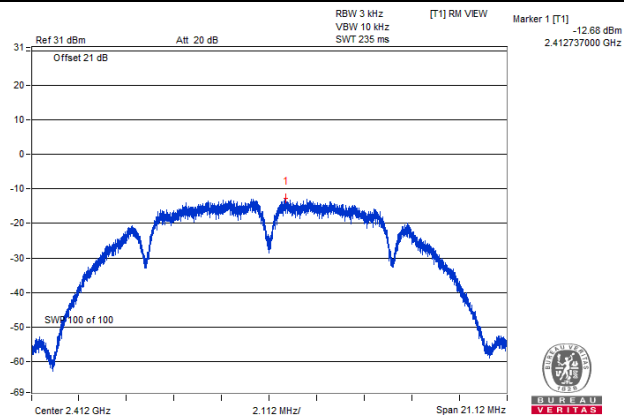

802.11g / CH6

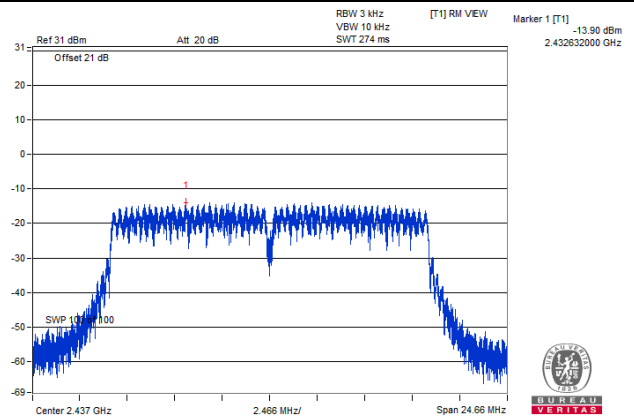

802.11ax (HE20) / CH6

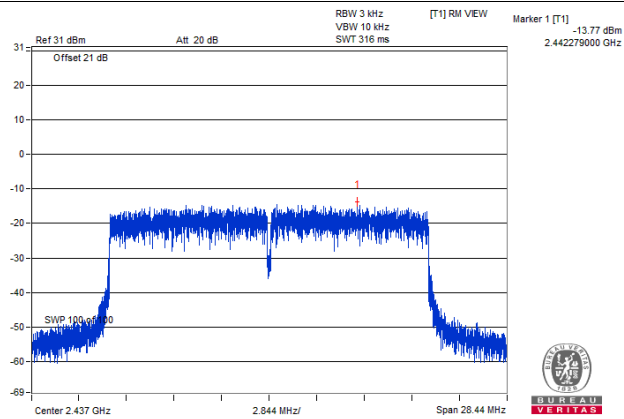

802.11ax (HE40) / CH6

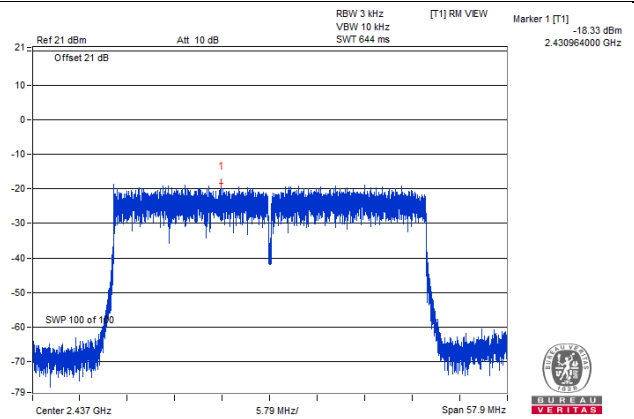

802.11ax (RU26) / CH6

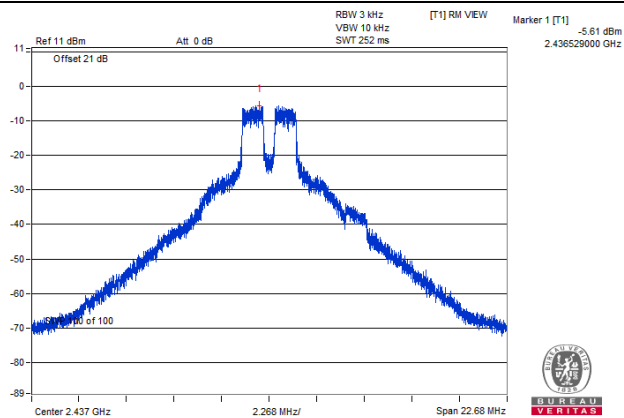

802.11ax (RU52) / CH6

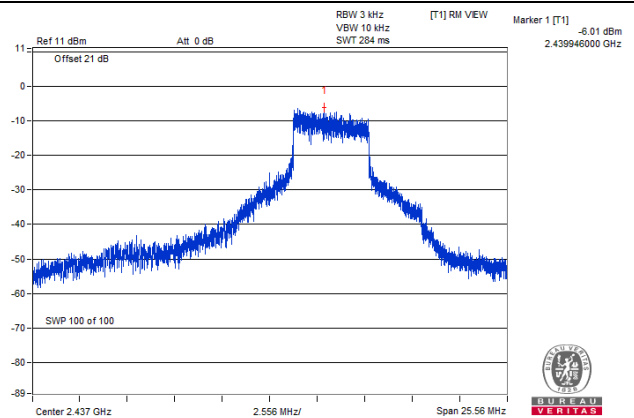

802.11ax (RU106) / CH6

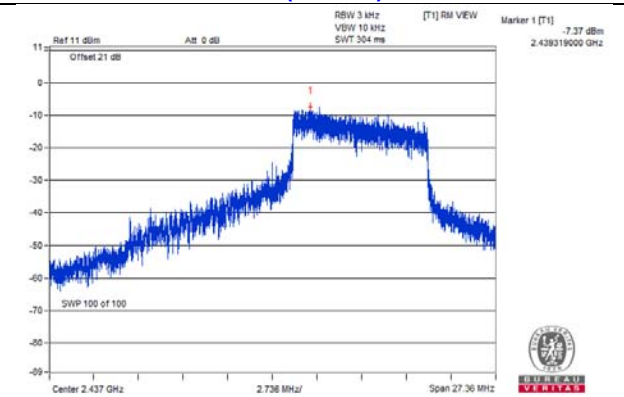

4.6 Conducted Out of Band Emission Measurement

4.6.1 Limits of Conducted Out of Band Emission Measurement

Below 30dB of the highest emission level of operating band (in 100kHz Resolution Bandwidth).

4.6.2 Test Setup

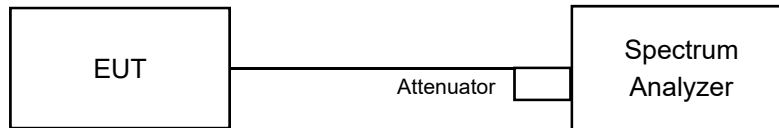

4.6.3 Test Instruments

Refer to section 4.1.2 to get information of above instrument.

4.6.4 Test Procedure

MEASUREMENT PROCEDURE REF

1. Set the RBW = 100 kHz.
2. Set the VBW \geq 300 kHz.
3. Detector = peak.
4. Sweep time = auto couple.
5. Trace mode = max hold.
6. Allow trace to fully stabilize.
7. Use the peak marker function to determine the maximum power level in any 100 kHz band segment within the fundamental EBW.

MEASUREMENT PROCEDURE OOBE

1. Set RBW = 100 kHz.
2. Set VBW \geq 300 kHz.
3. Detector = peak.
4. Sweep = auto couple.
5. Trace Mode = max hold.
6. Allow trace to fully stabilize.
7. Use the peak marker function to determine the maximum amplitude level.

4.6.5 Deviation from Test Standard

No deviation.

4.6.6 EUT Operating Condition

Same as Item 4.3.6

4.6.7 Test Results

The spectrum plots are attached on the following pages. D1 line indicates the highest level, and D2 line indicates the 30dB offset below D1. It shows compliance with the requirement.

For Mode 1
802.11b

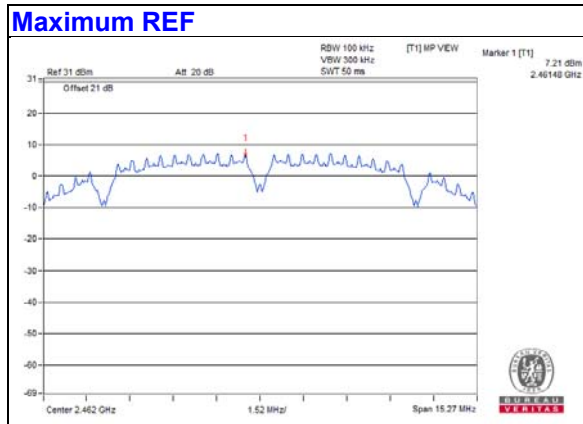

Chain 0

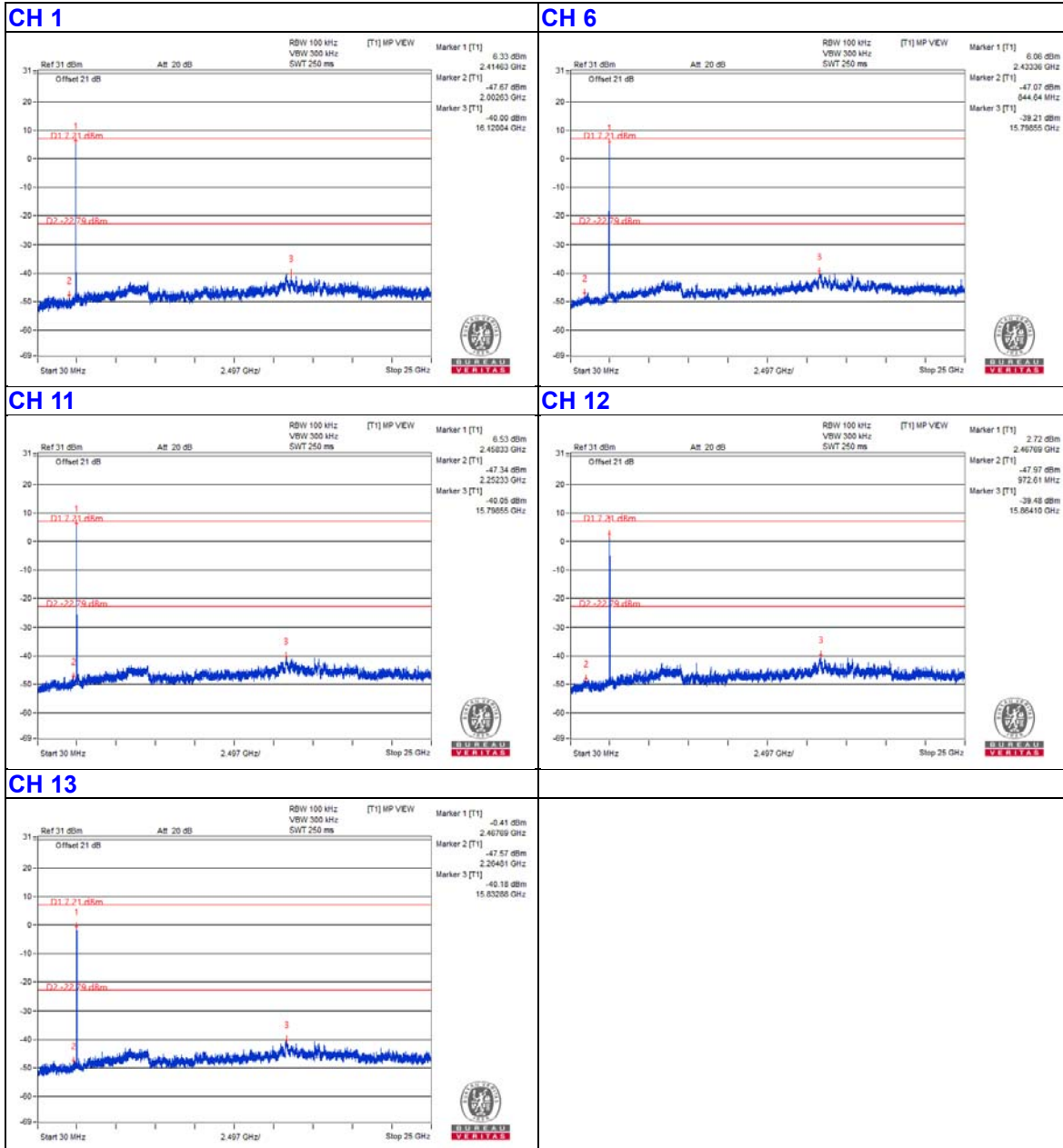

CH 1 Band edge

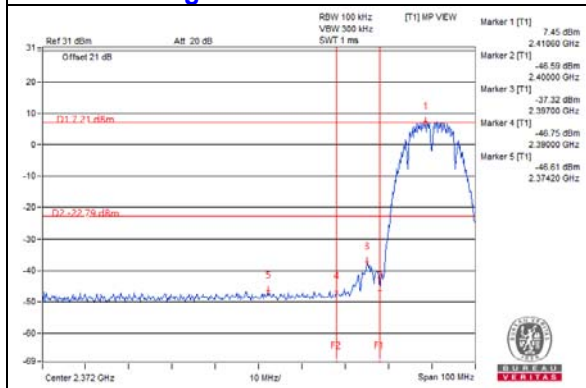

CH 11 Band edge

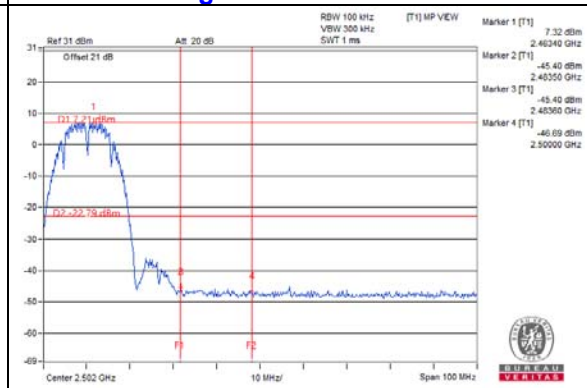

CH 12 Band edge

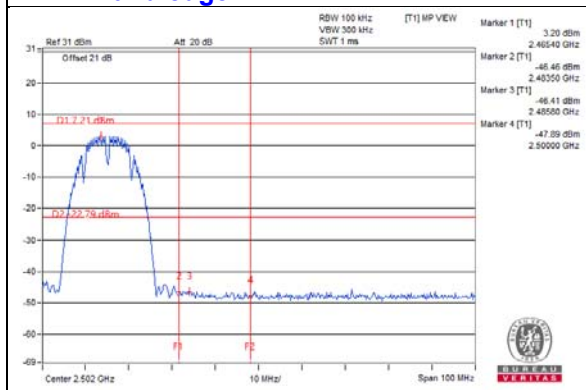

CH 13 Band edge

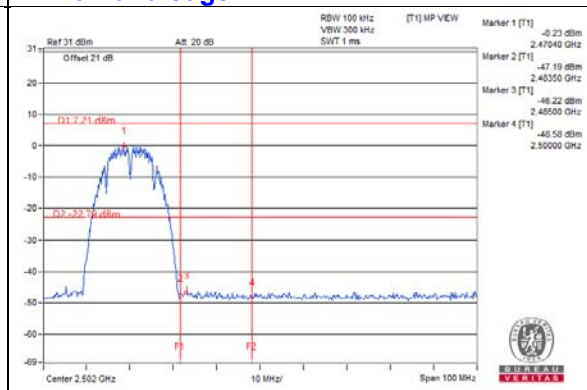

Chain 1

CH 1

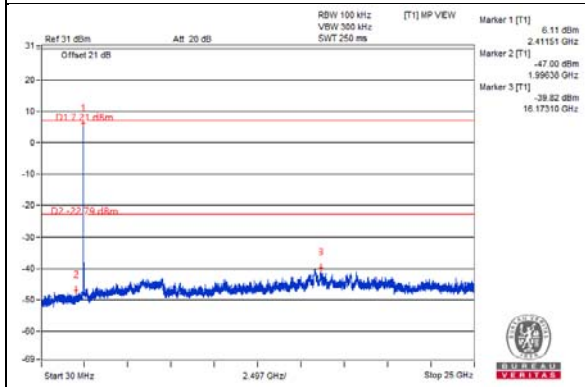

CH 6

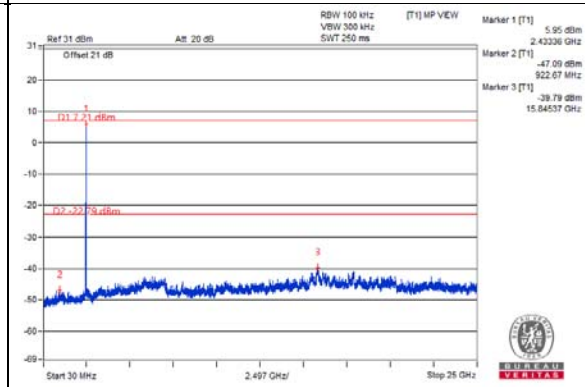

CH 11

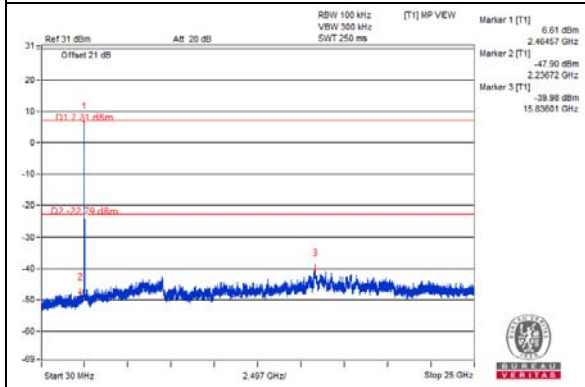

CH 12

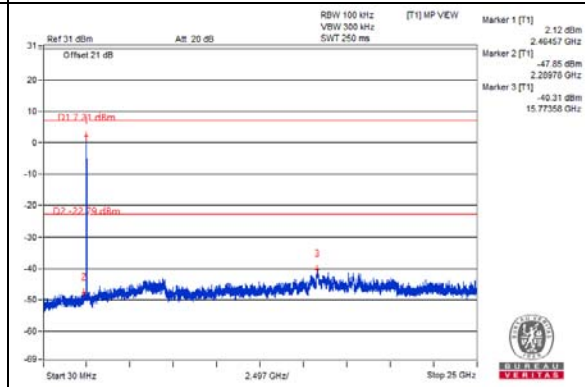

CH 13

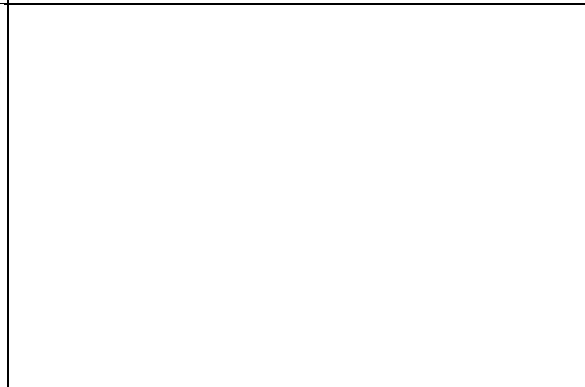
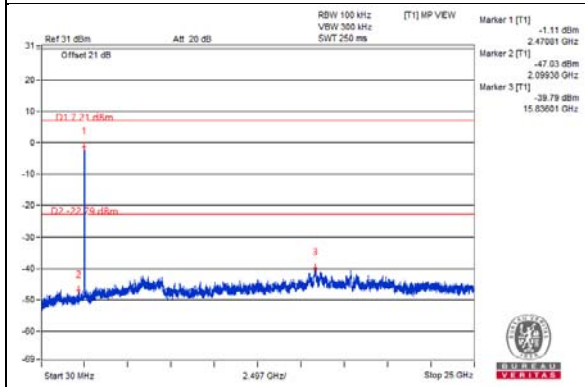

CH 1 Band edge

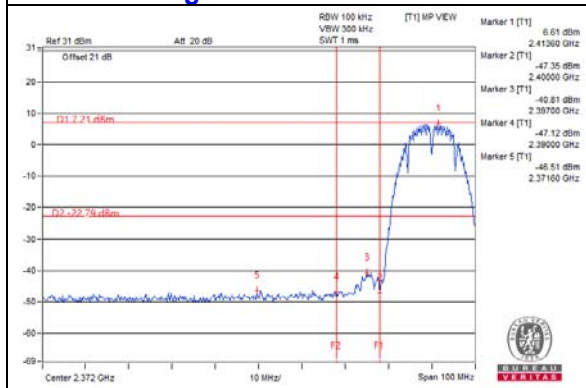

CH 11 Band edge

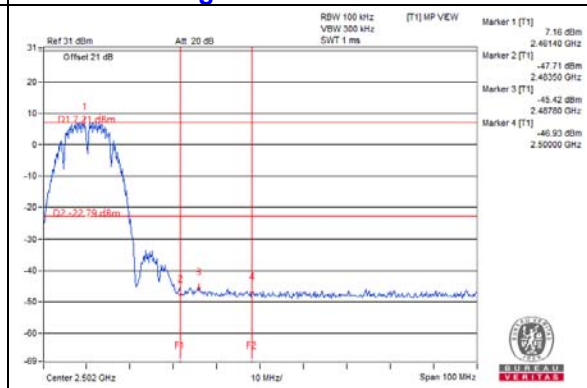

CH 12 Band edge

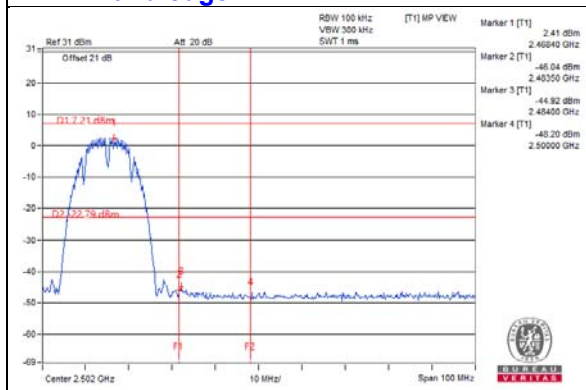

CH 13 Band edge

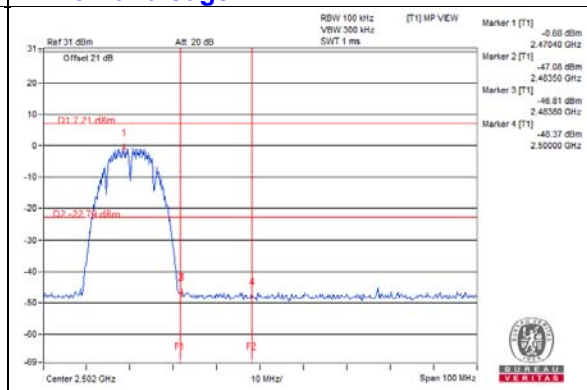

802.11g

Maximum REF

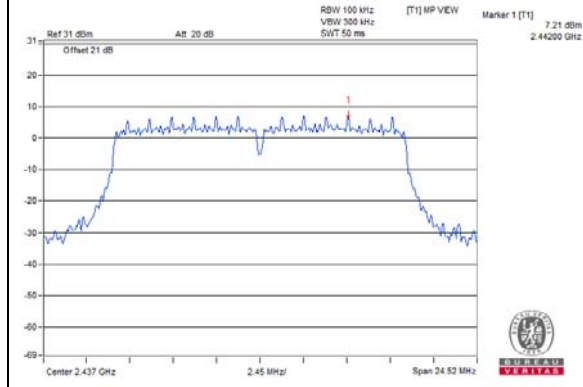

Chain 0

CH 1

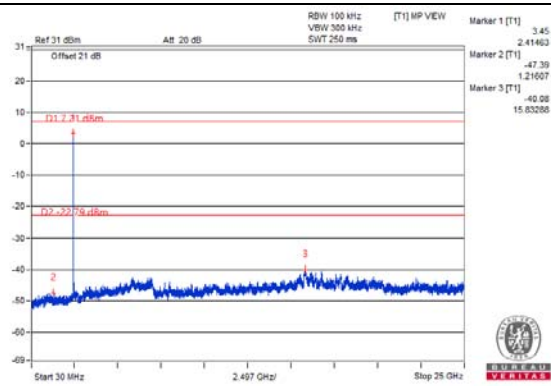

CH 6

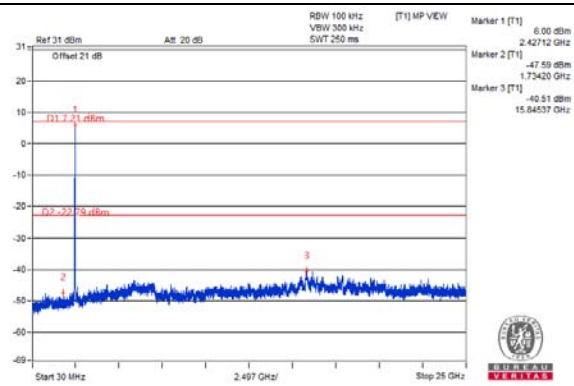

CH 11

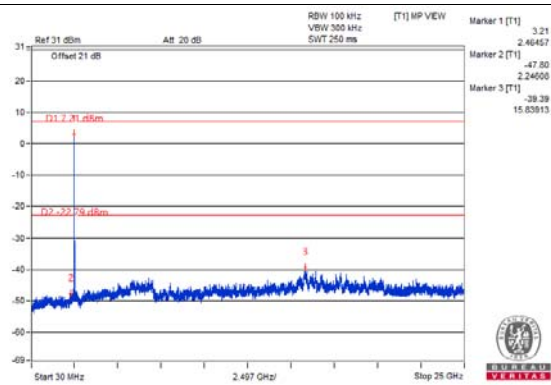

CH 12

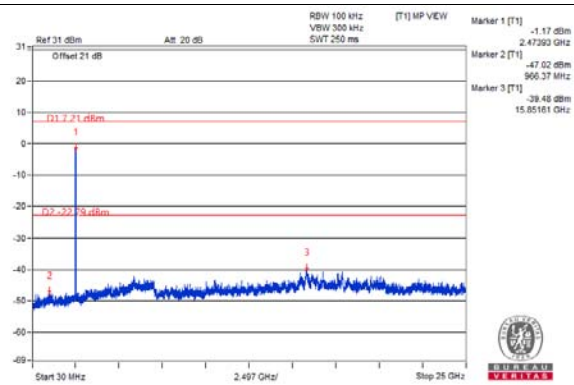

CH 13

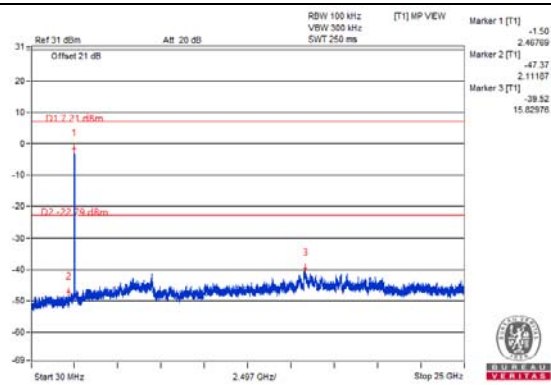

CH 1 Band edge

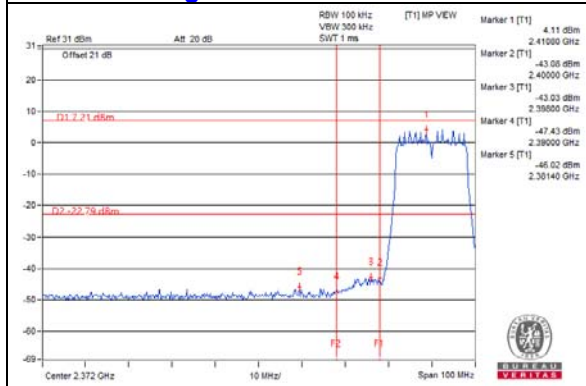

CH 11 Band edge

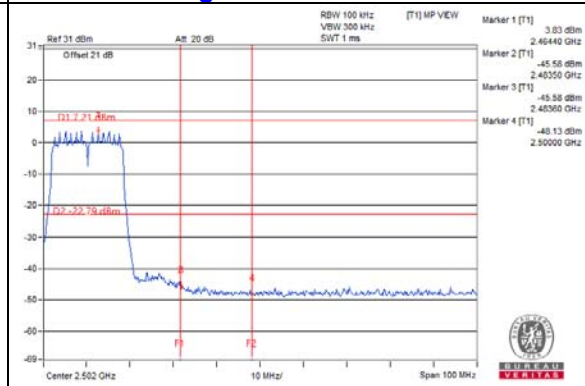

CH 12 Band edge

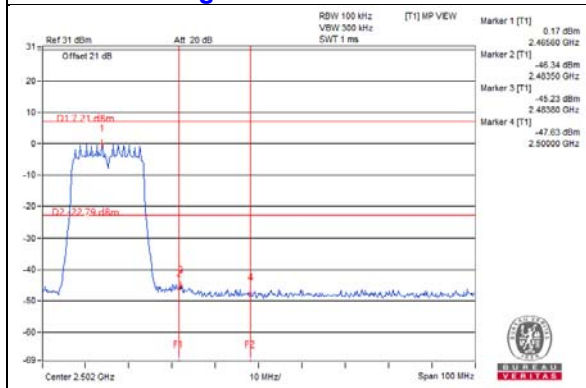

CH 13 Band edge

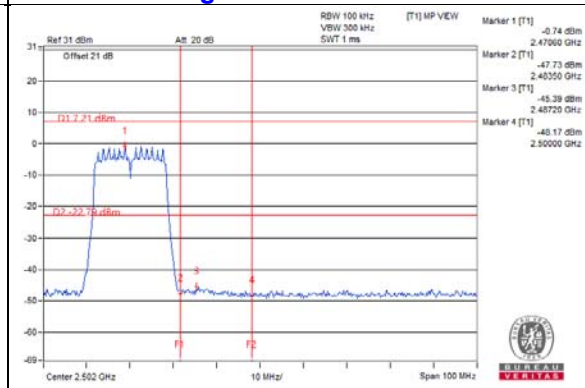

Chain 1

CH 1

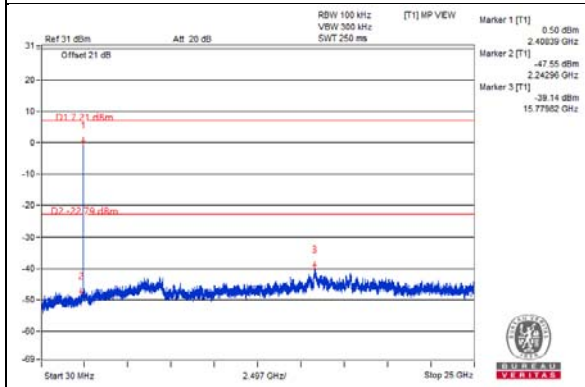

CH 6

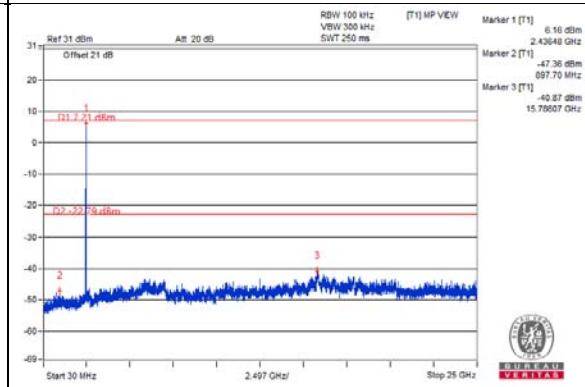

CH 11

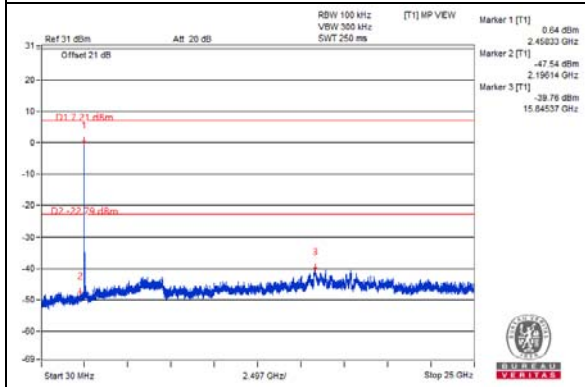

CH 12

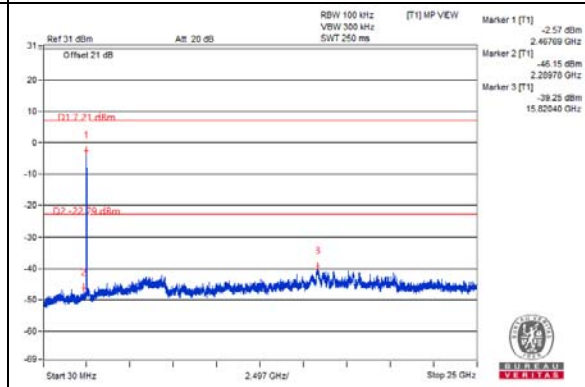

CH 13

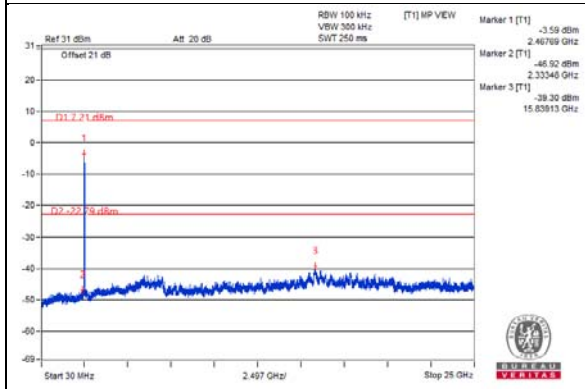

CH 1 Band edge

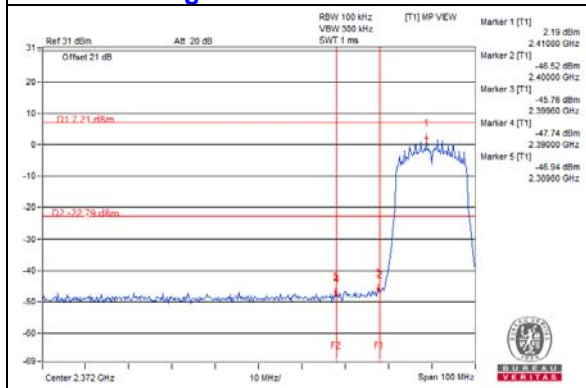

CH 11 Band edge

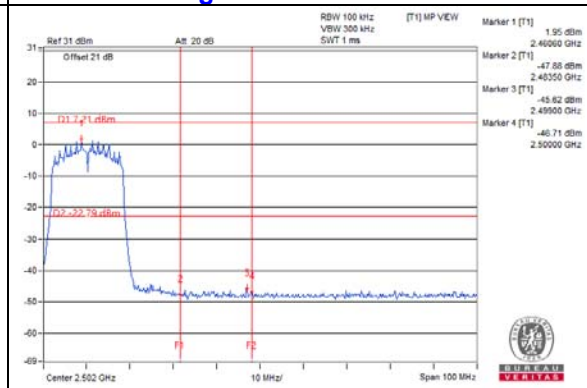

CH 12 Band edge

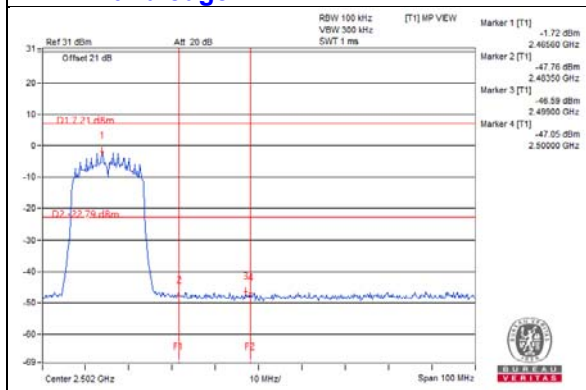

CH 13 Band edge

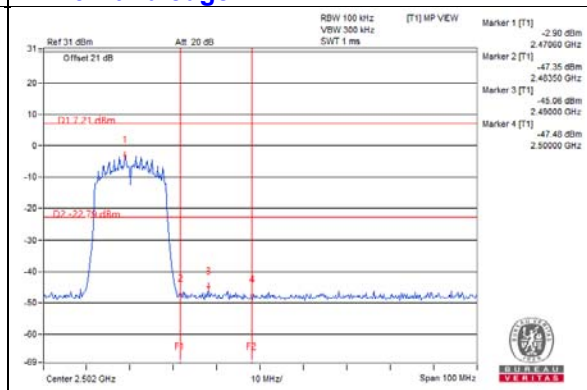

802.11ax (HE20)

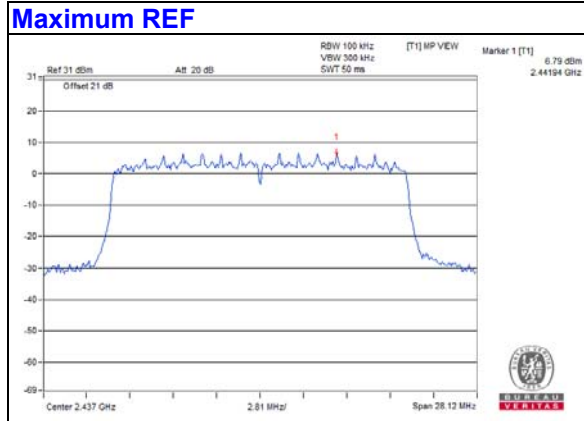

Chain 0

CH 1

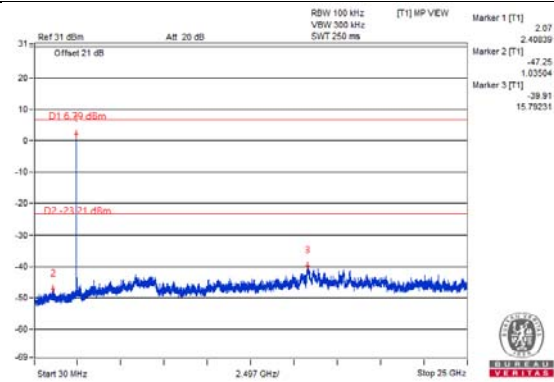

CH 6

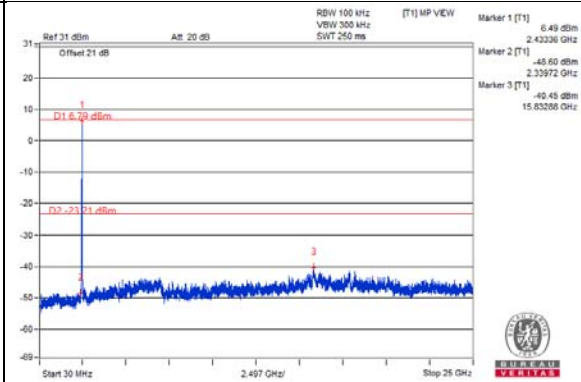

CH 11

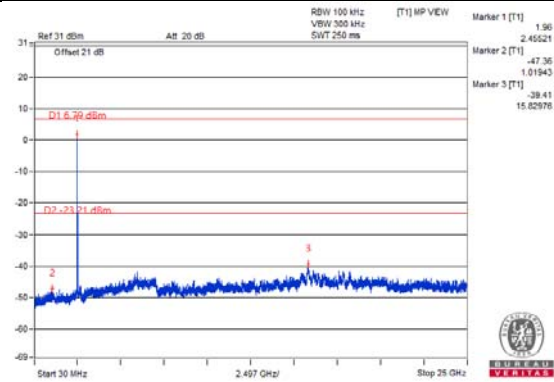

CH 12

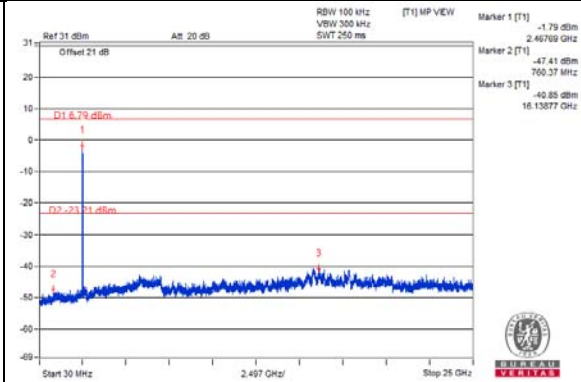

CH 13

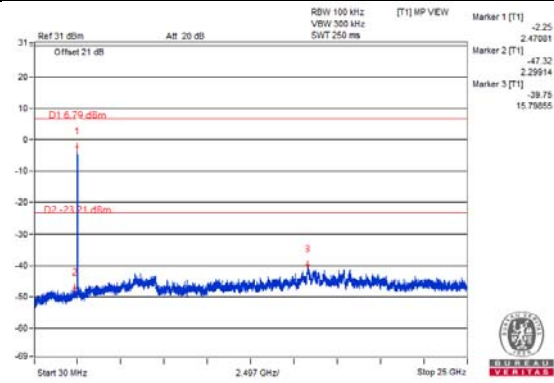

CH 1 Band edge

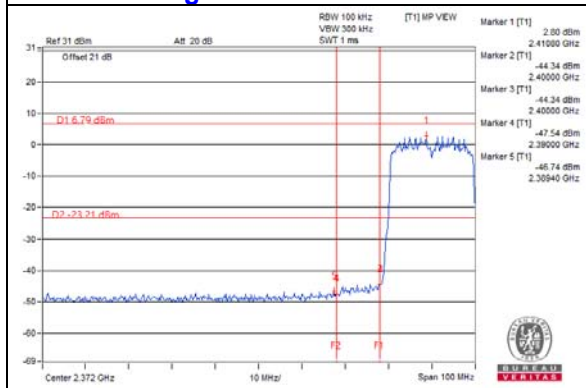

CH 11 Band edge

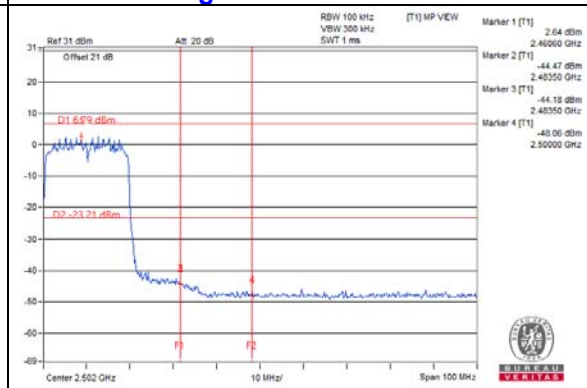

CH 12 Band edge

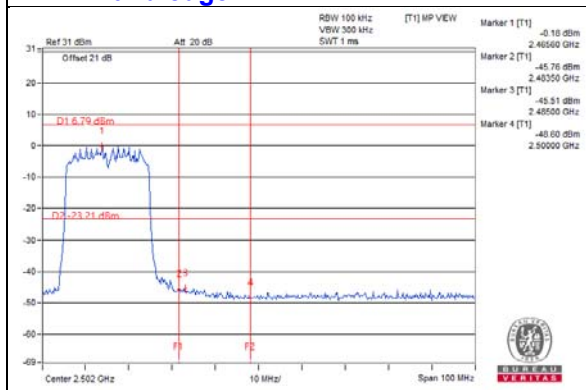

CH 13 Band edge

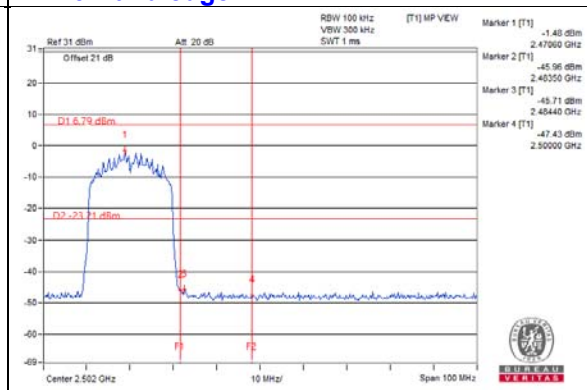

Chain 1

CH 1

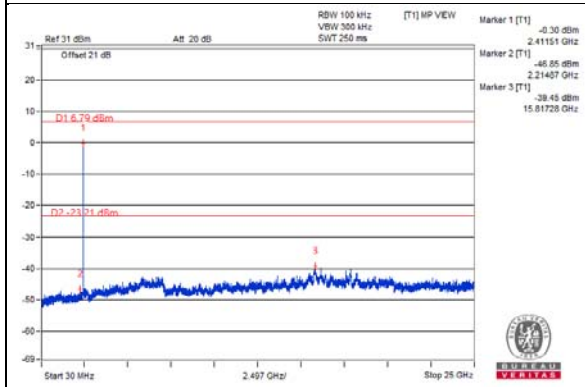

CH 6

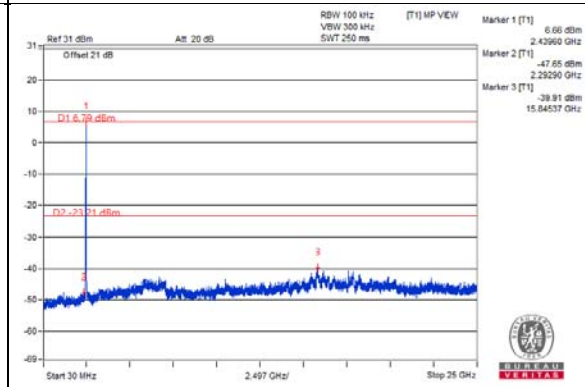

CH 11

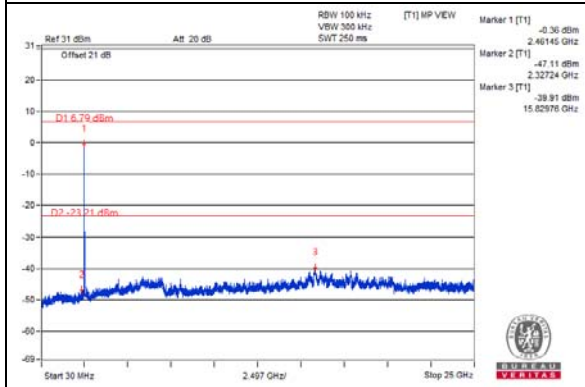

CH 12

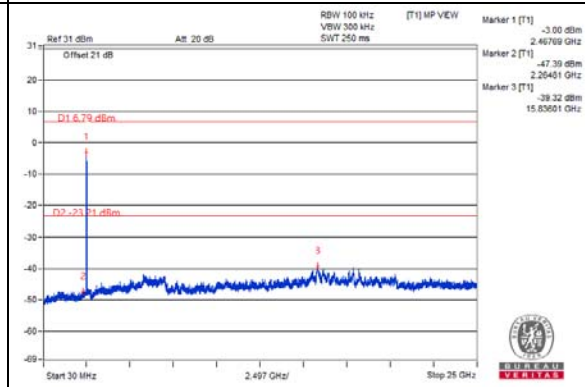

CH 13

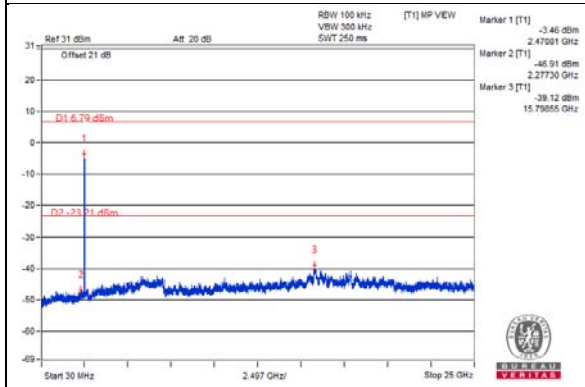

CH 1 Band edge

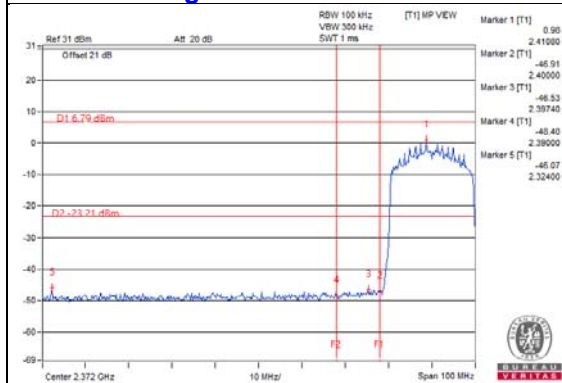

CH 11 Band edge

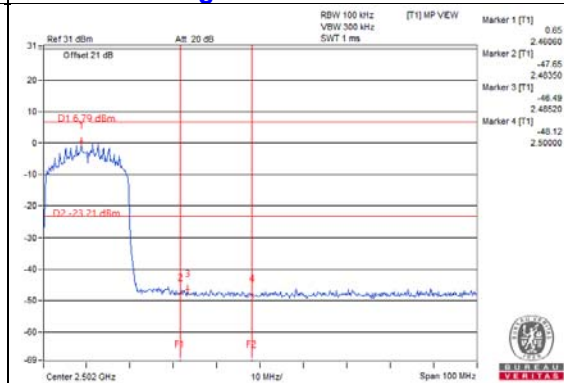

CH 12 Band edge

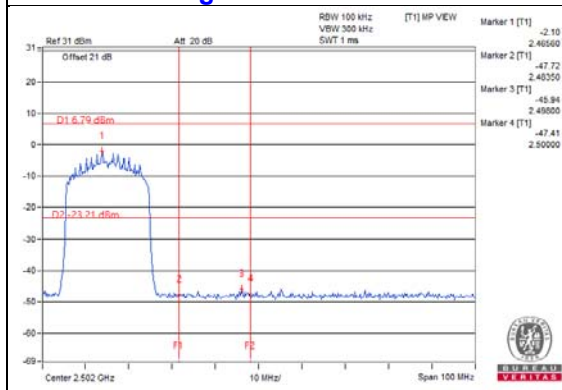

CH 13 Band edge

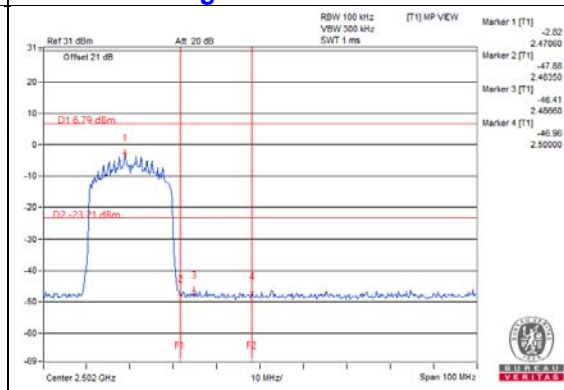

802.11ax (HE40)

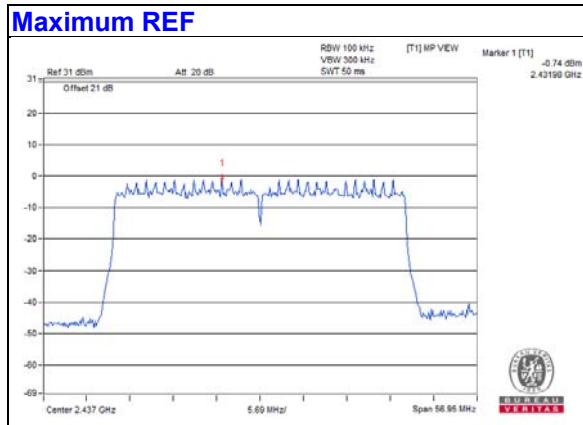

Chain 0

CH 3

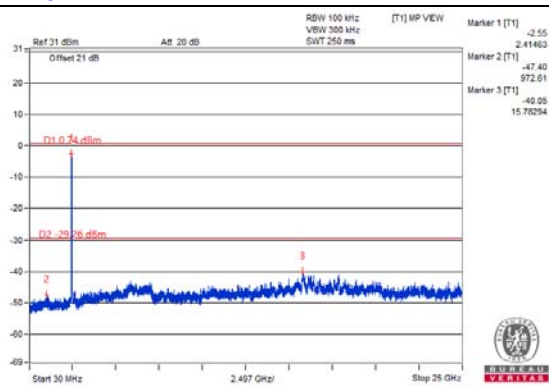

CH 6

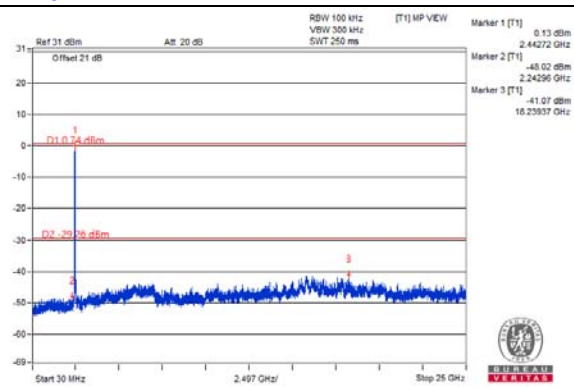

CH 9

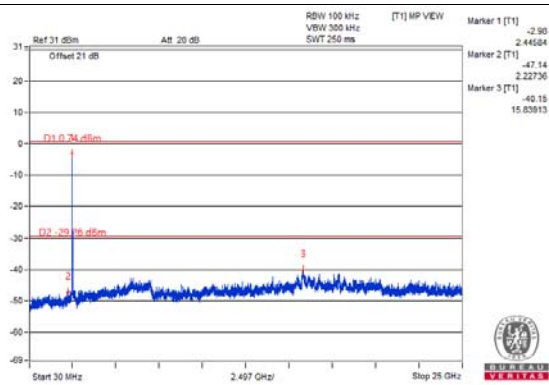

CH 10

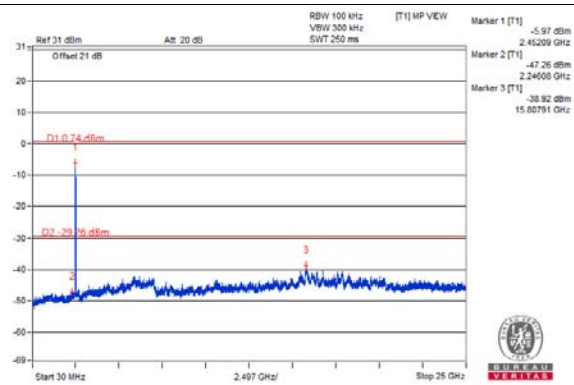

CH 11

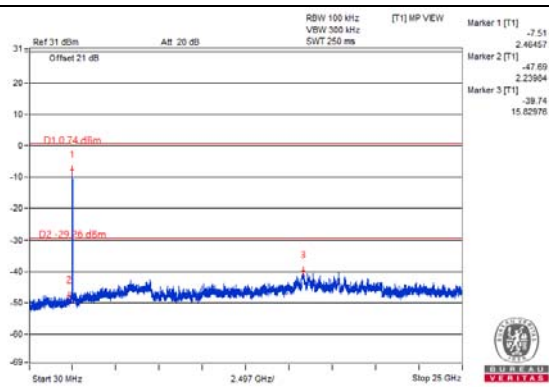

CH 3 Band edge

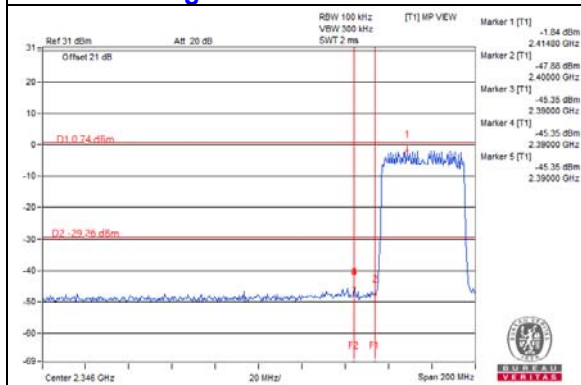

CH 9 Band edge

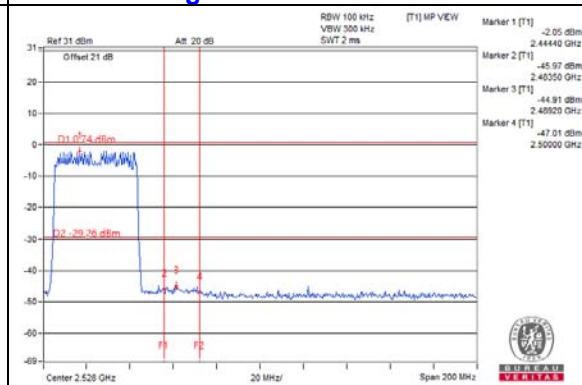

CH 10 Band edge

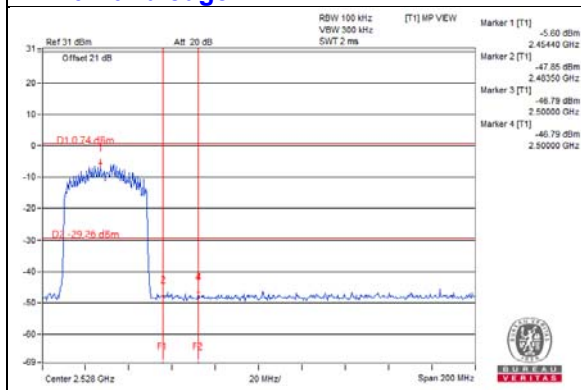

CH 11 Band edge

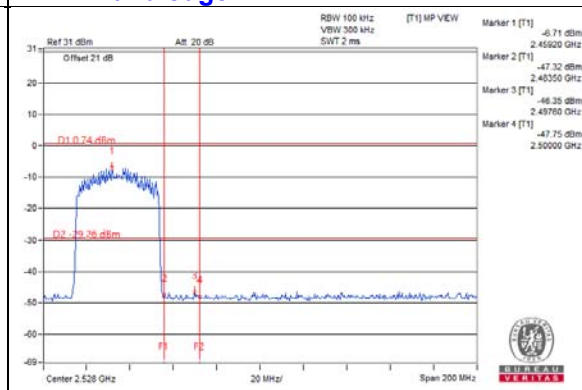

Chain 1

CH 3

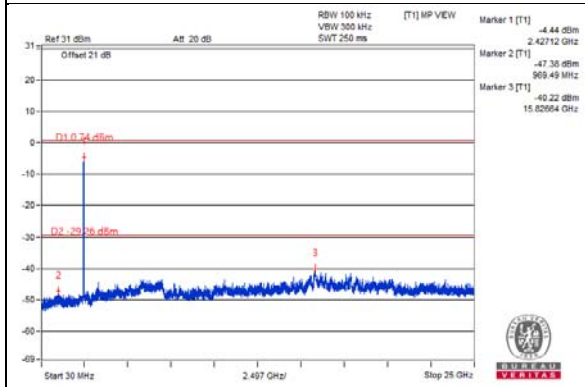

CH 6

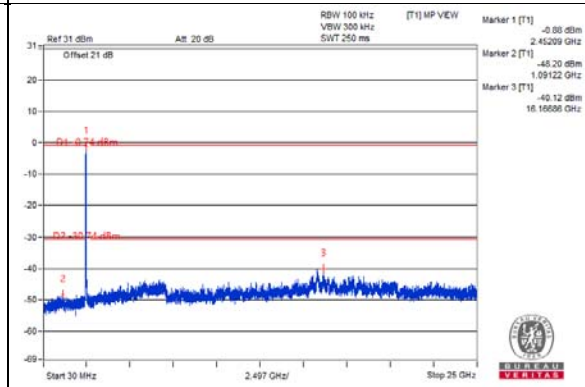

CH 9

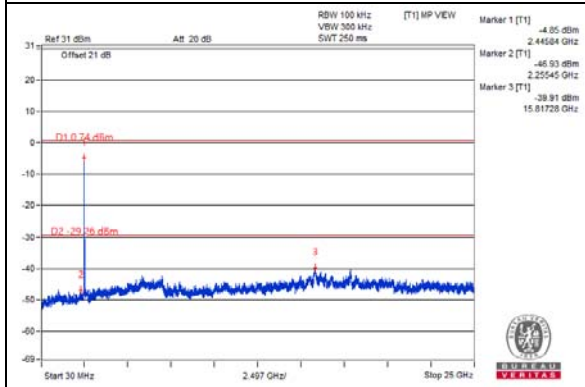

CH 10

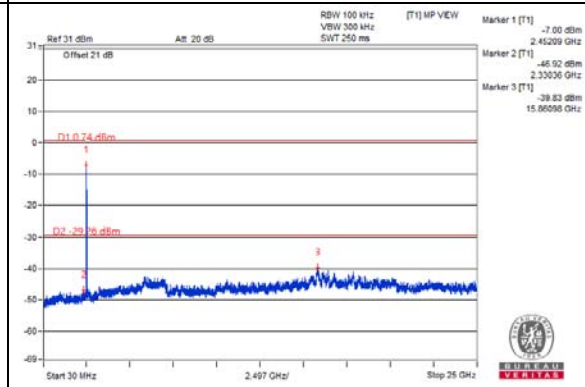

CH 11

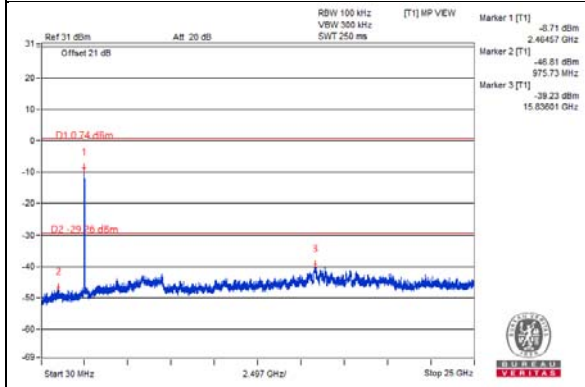

CH 3 Band edge

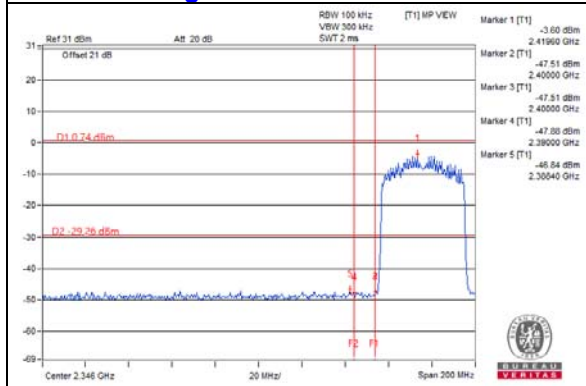

CH 9 Band edge

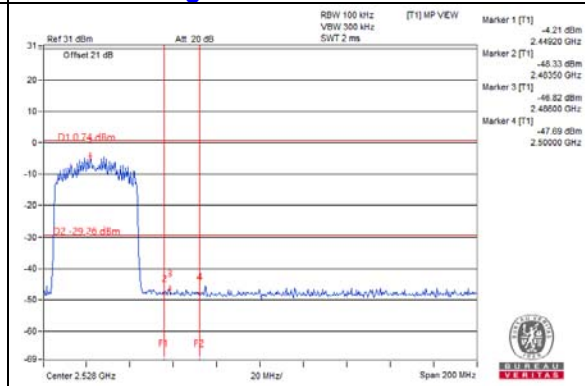

CH 10 Band edge

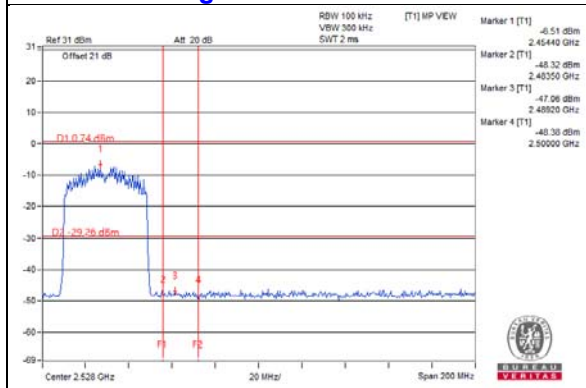

CH 11 Band edge

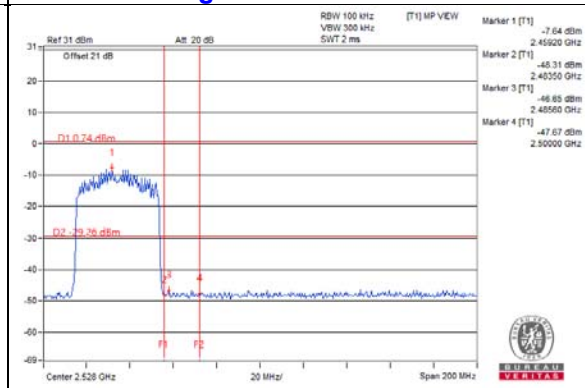

802.11ax (RU26)

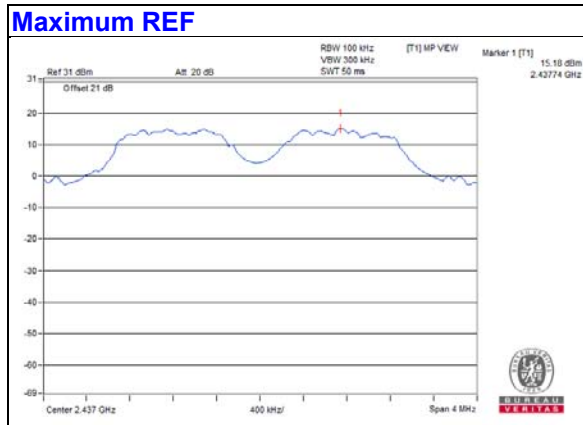

Chain 0

CH 1

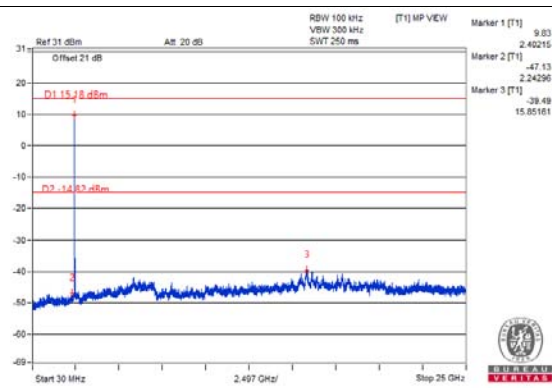

CH 6

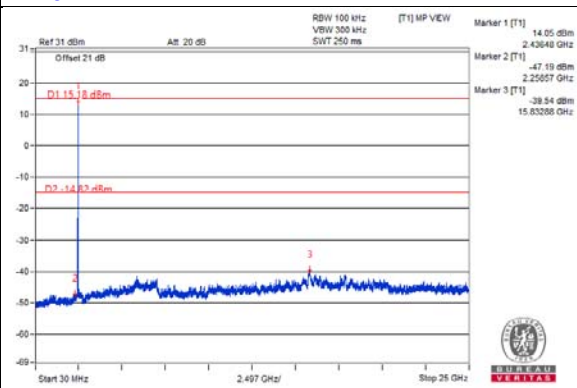

CH 11

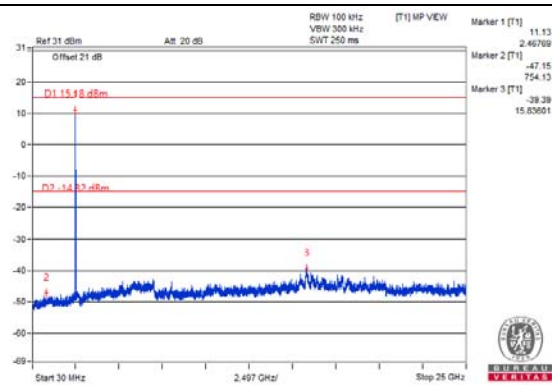

CH 12

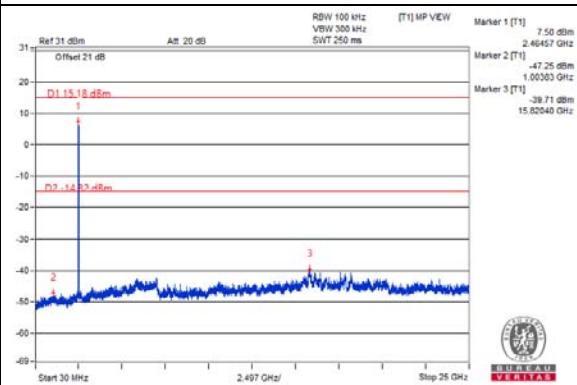

CH 13

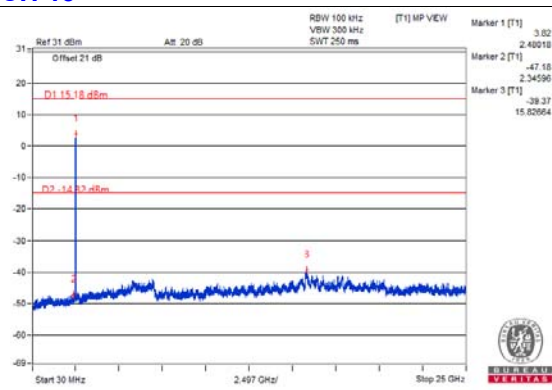

CH 1 Band edge

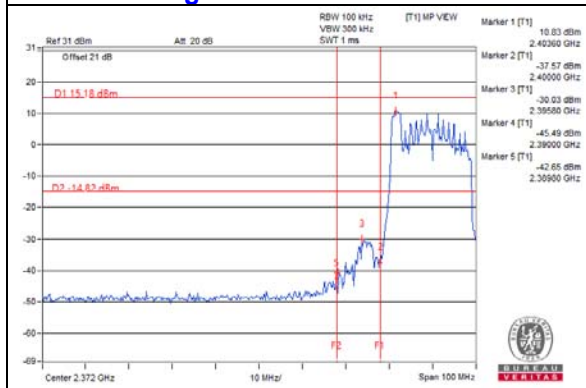

CH 11 Band edge

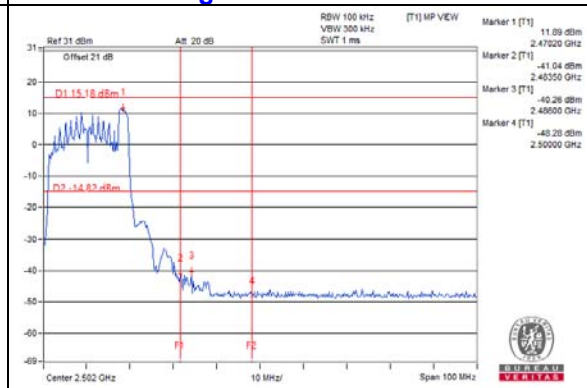

CH 12 Band edge

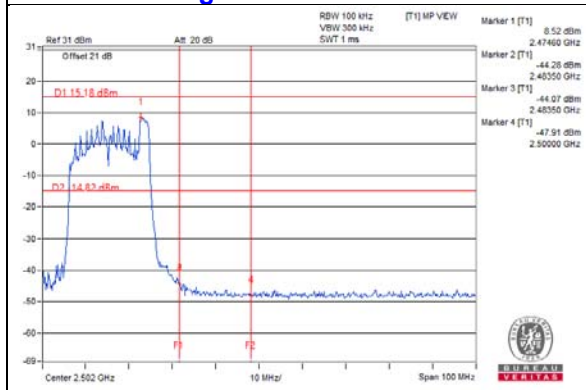

CH 13 Band edge

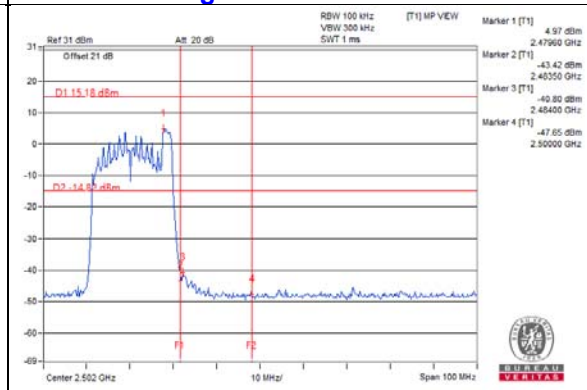

Chain 1

CH 1

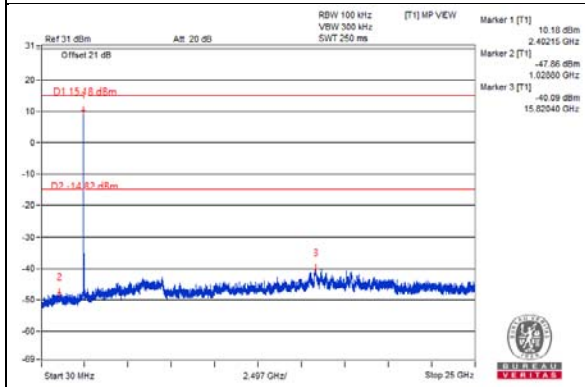

CH 6

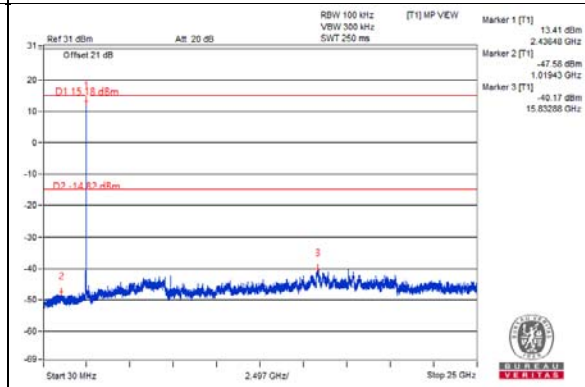

CH 11

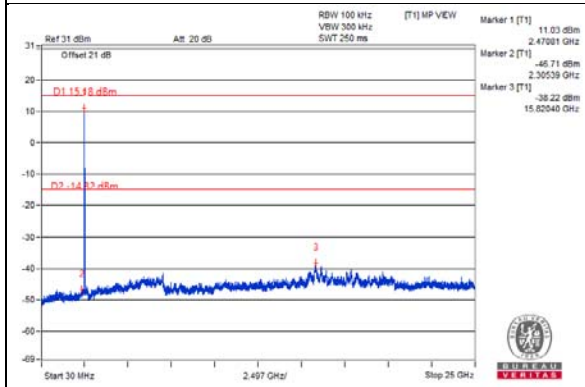

CH 12

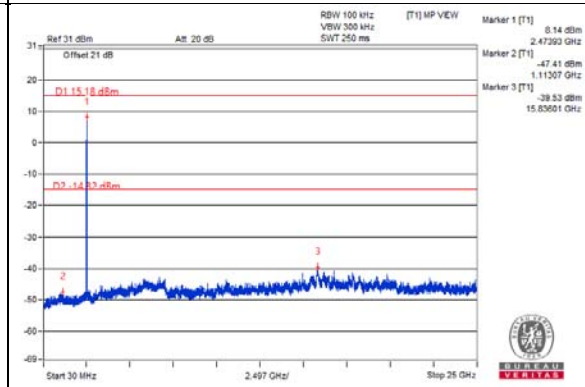

CH 13

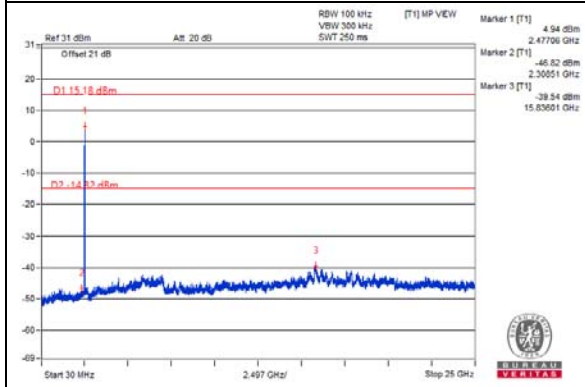

CH 1 Band edge

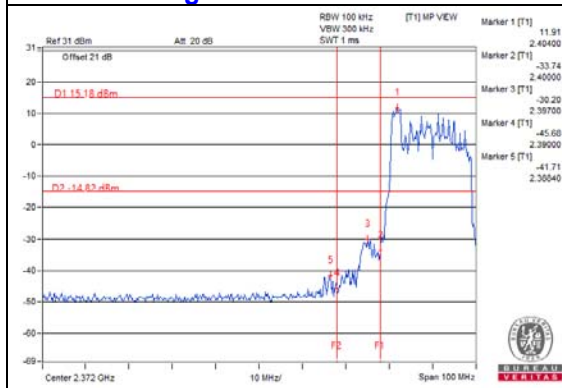

CH 11 Band edge

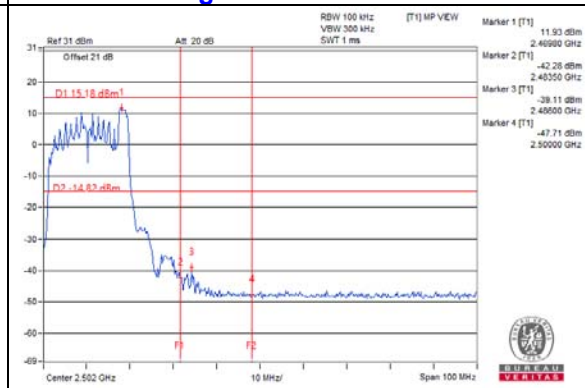

CH 12 Band edge

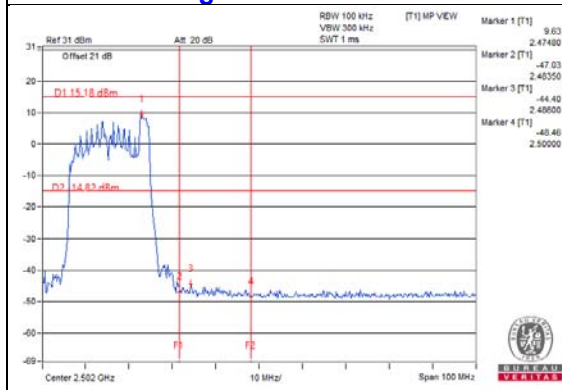

CH 13 Band edge

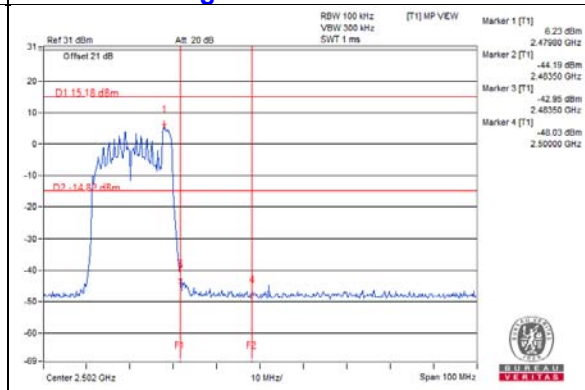

802.11ax (RU52)

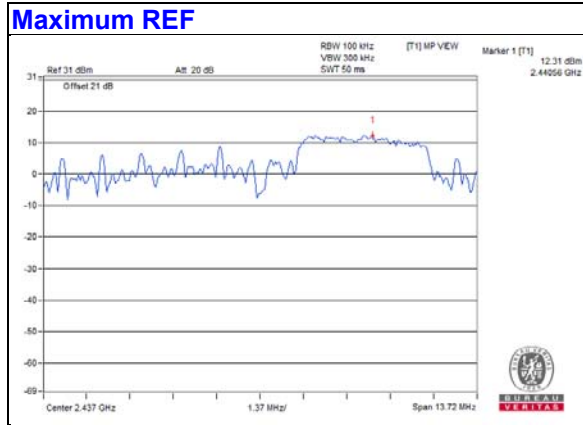

Chain 0

CH 1

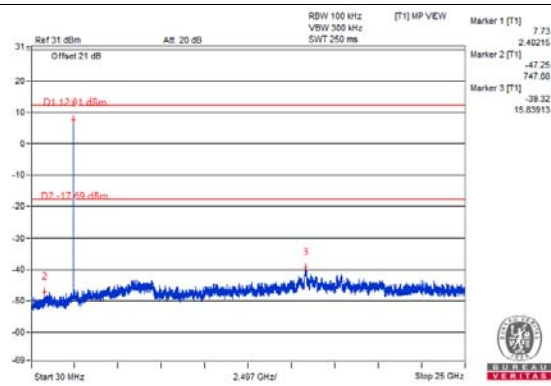

CH 6

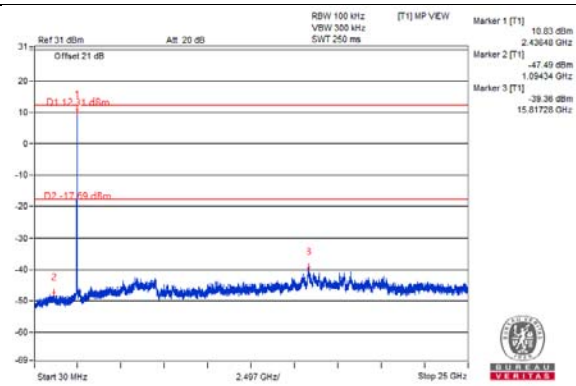

CH 11

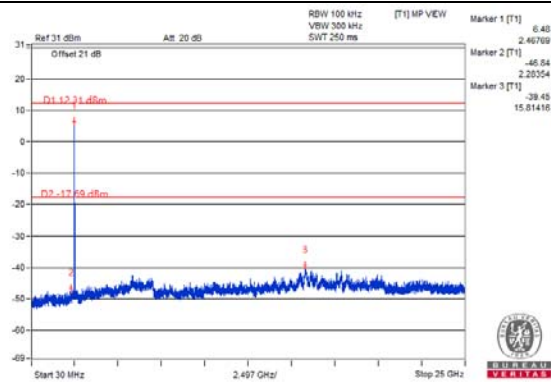

CH 12

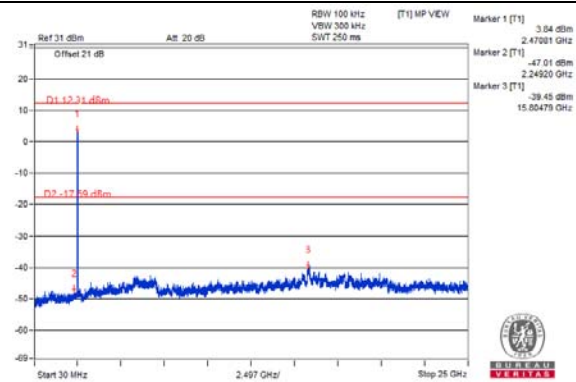

CH 13

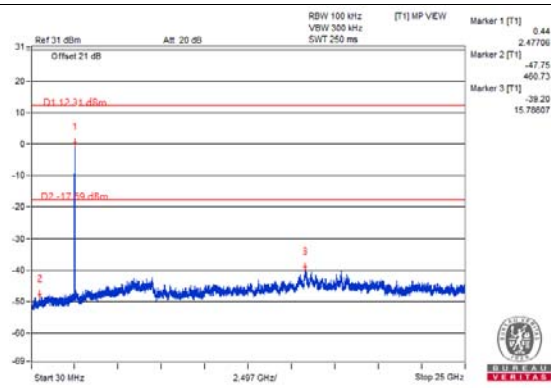

CH 1 Band edge

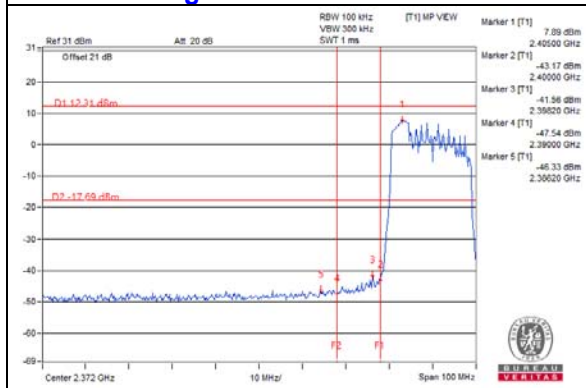

CH 11 Band edge

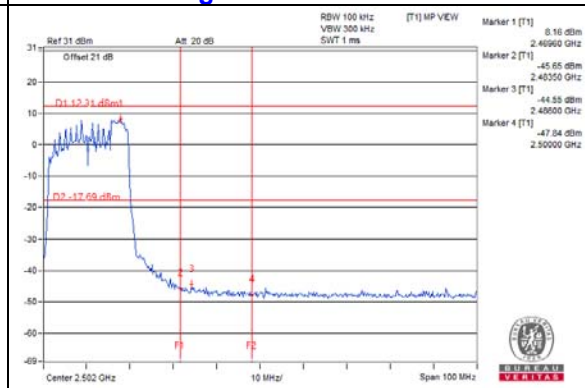

CH 12 Band edge

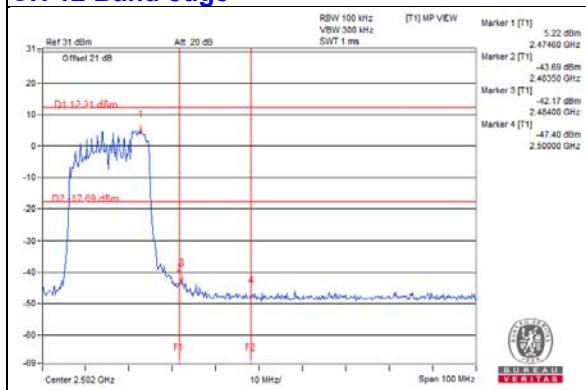

CH 13 Band edge

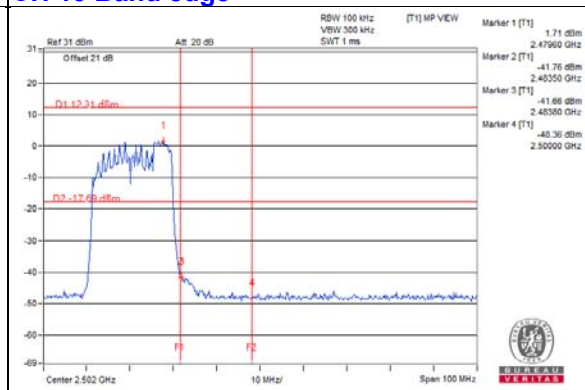

Chain 1

CH 1

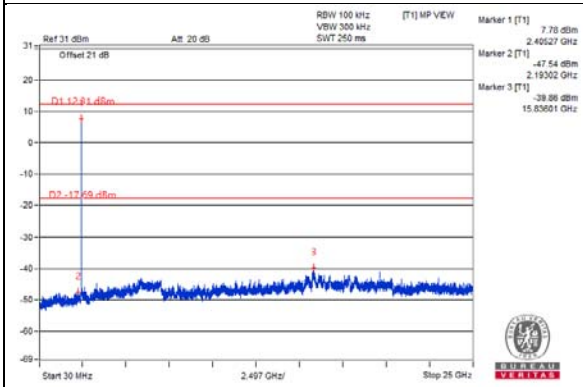

CH 6

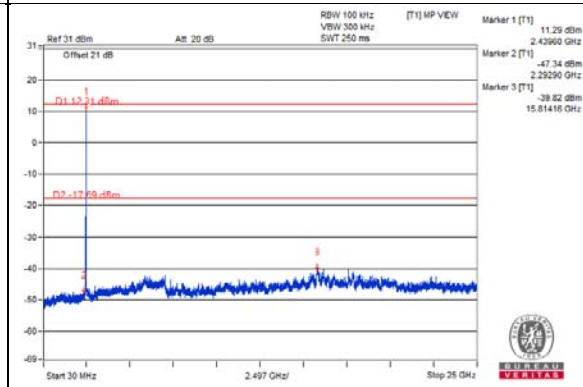

CH 11

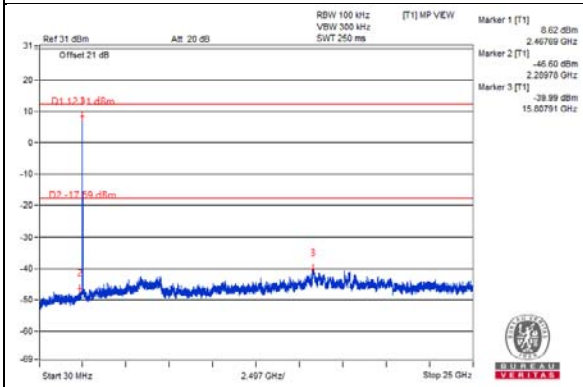

CH 12

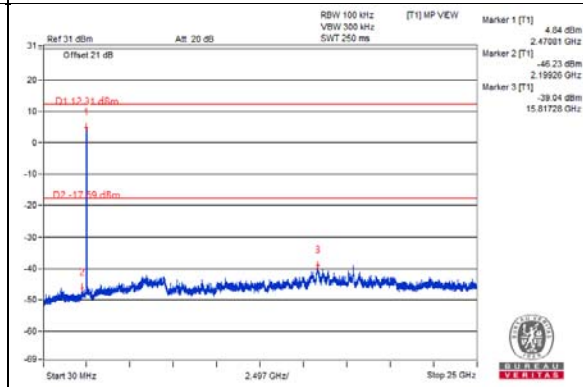

CH 13

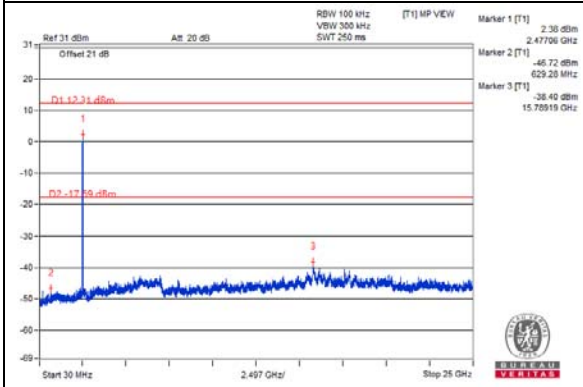

CH 1 Band edge

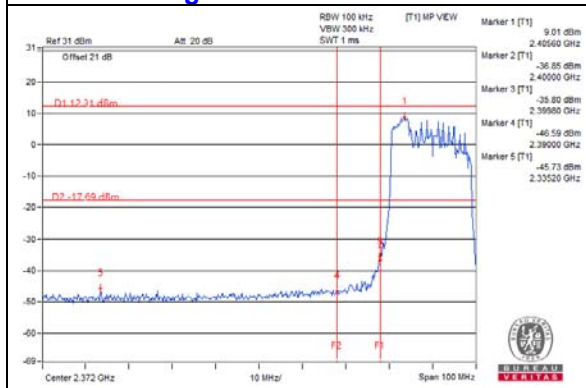

CH 11 Band edge

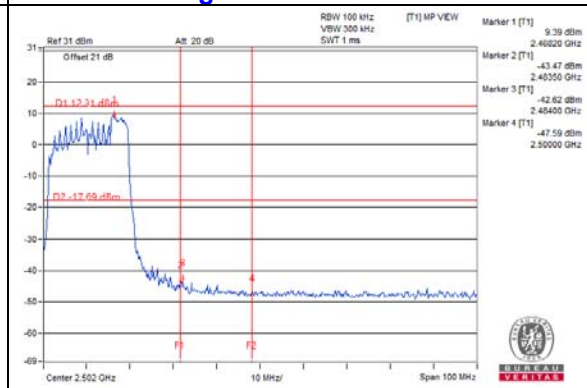

CH 12 Band edge

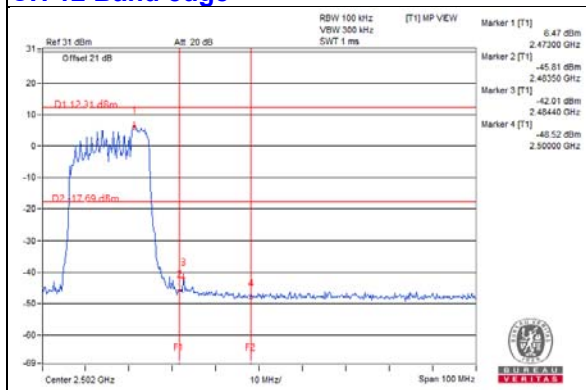

CH 13 Band edge

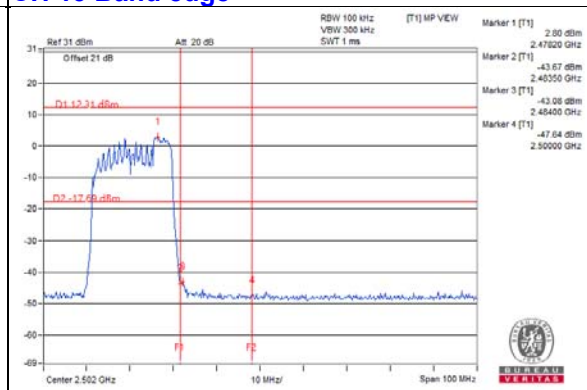

802.11ax (RU106)

Maximum REF

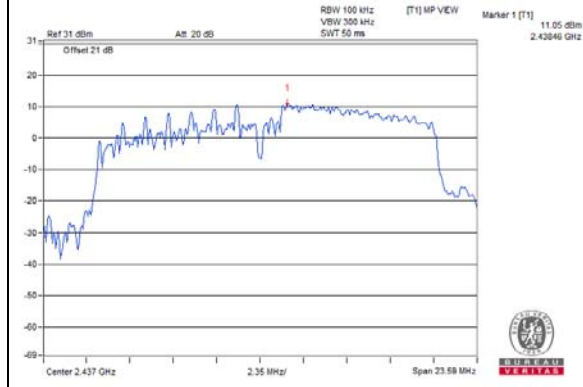

Chain 0

CH 1

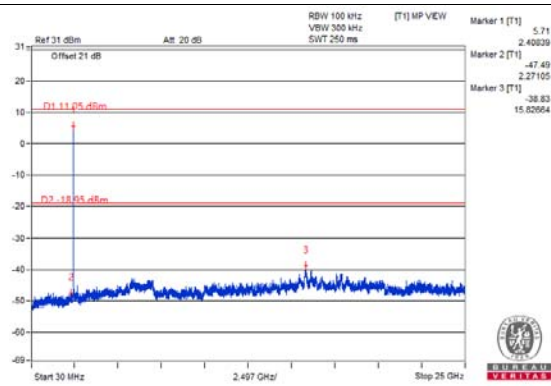

CH 6

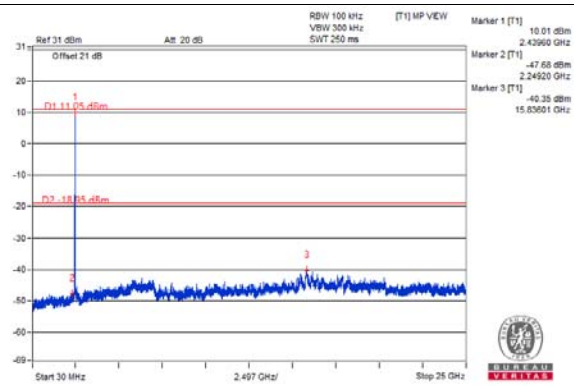

CH 11

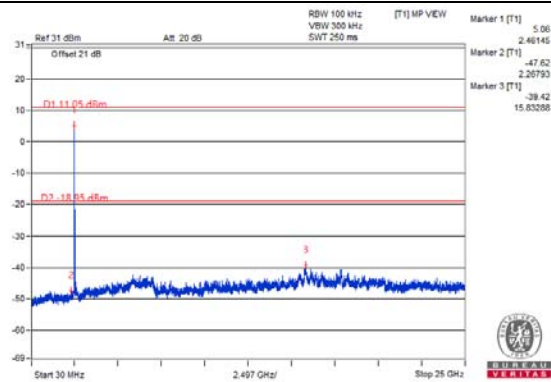

CH 12

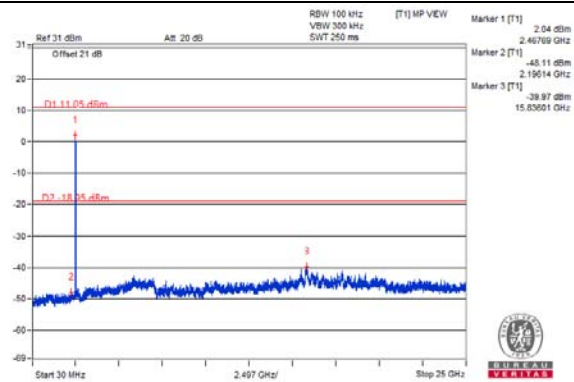

CH 13

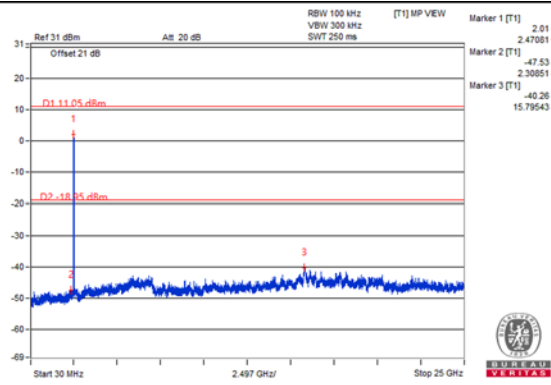

CH 1 Band edge

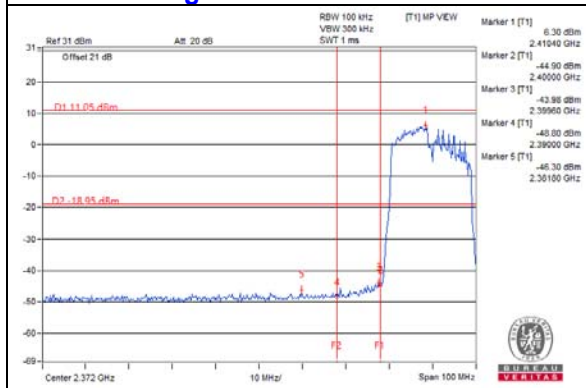

CH 11 Band edge

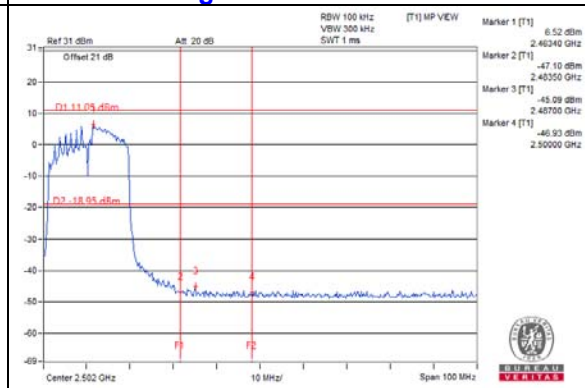

CH 12 Band edge

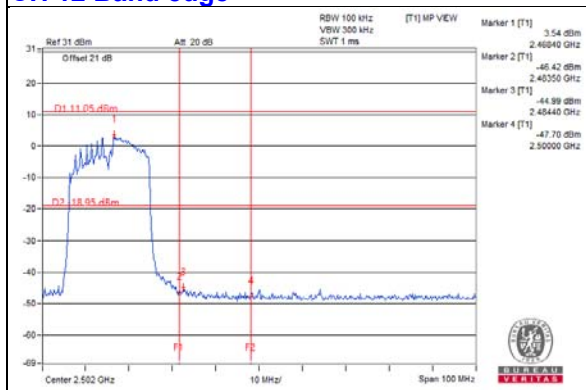

CH 13 Band edge

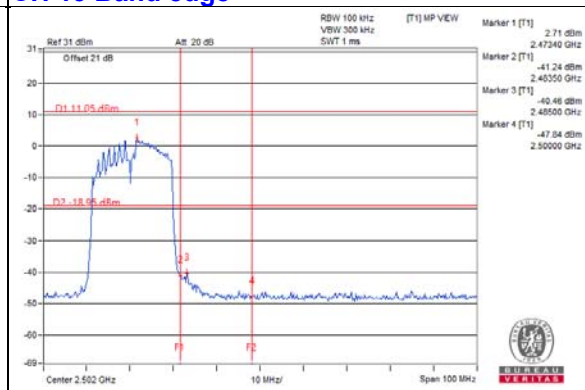

Chain 1

CH 1

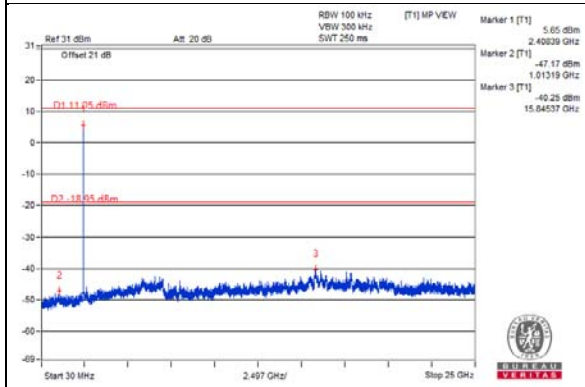

CH 6

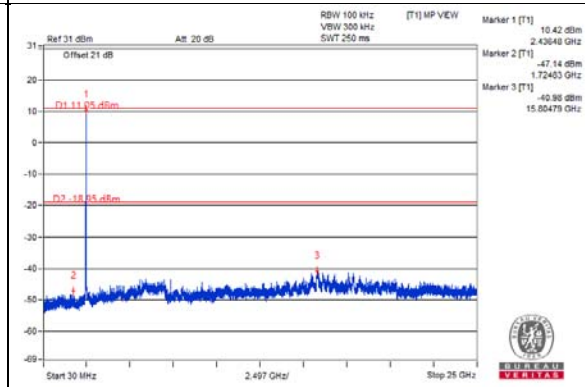

CH 11

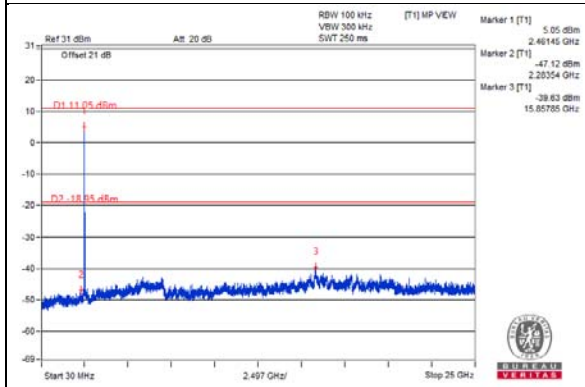

CH 12

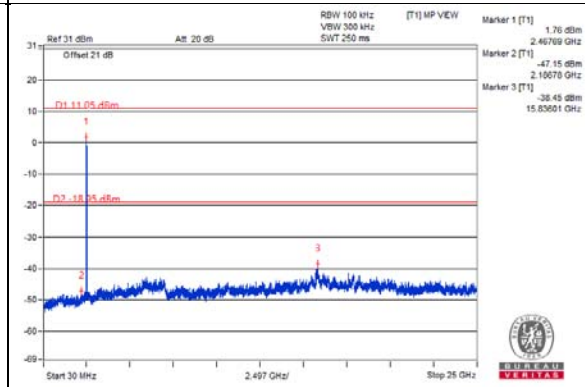

CH 13

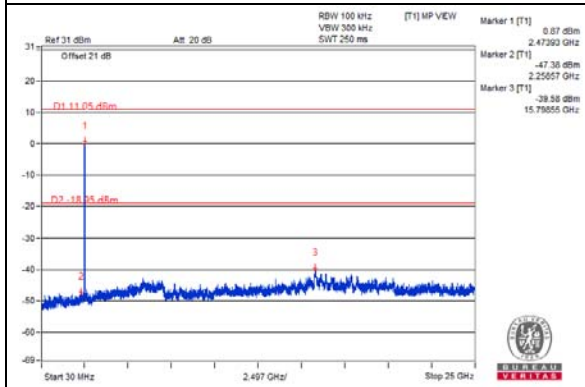

CH 1 Band edge

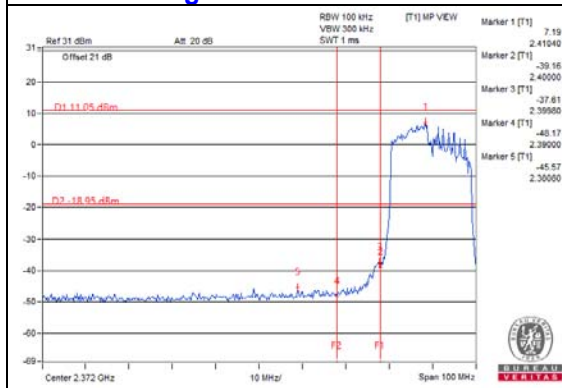

CH 11 Band edge

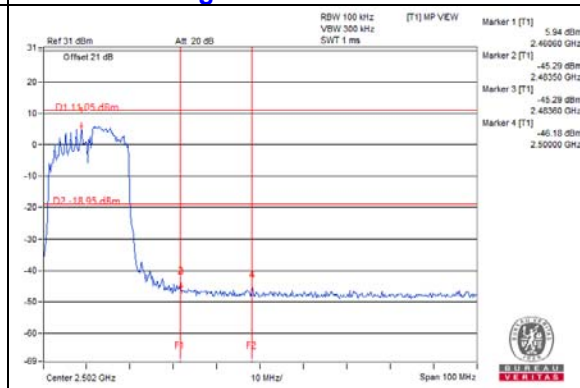

CH 12 Band edge

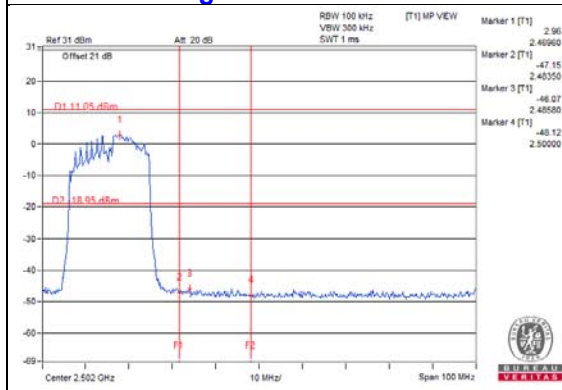

CH 13 Band edge

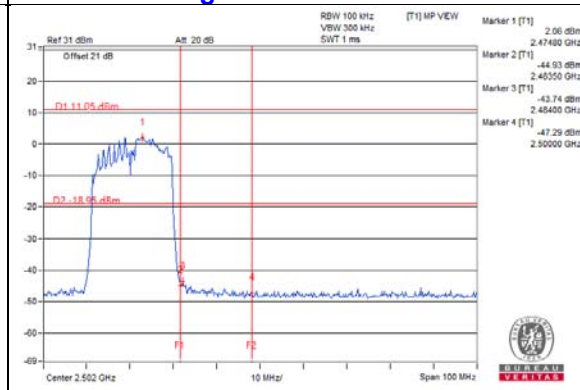

For Mode 2
802.11b

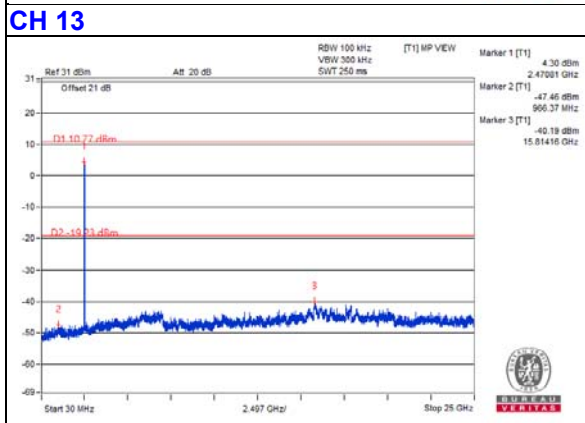
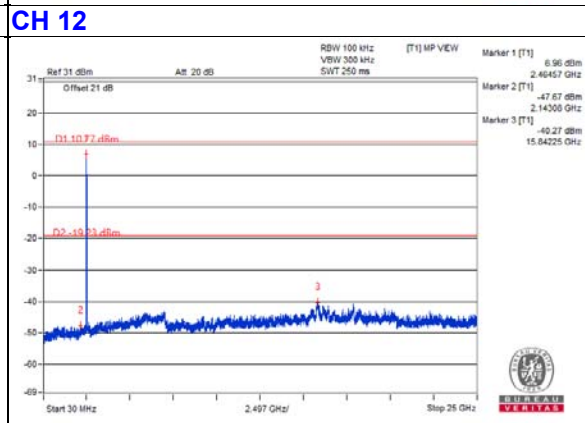
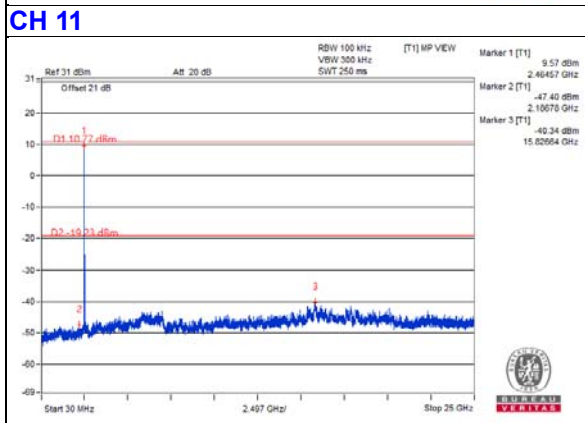
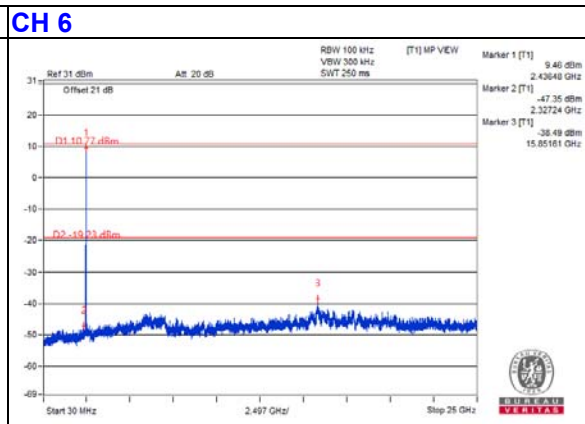
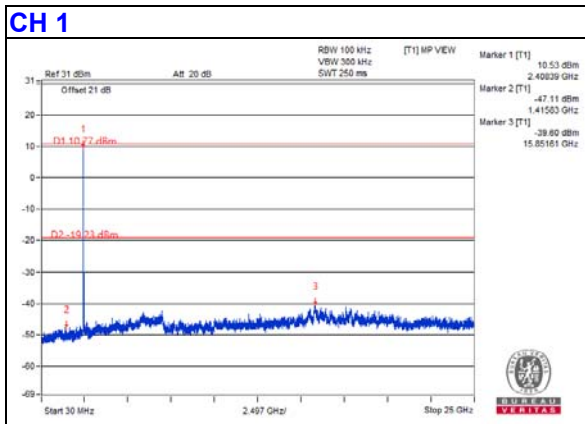
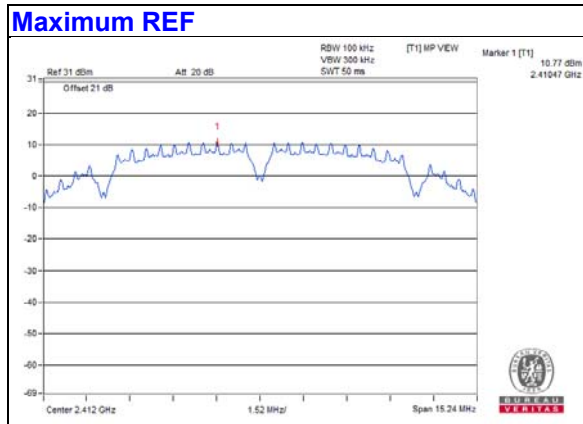

CH 1 Band edge

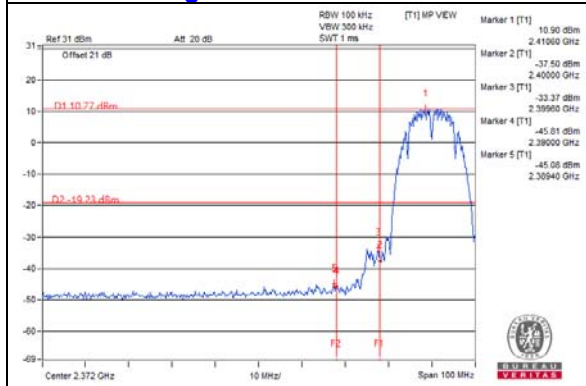

CH 11 Band edge

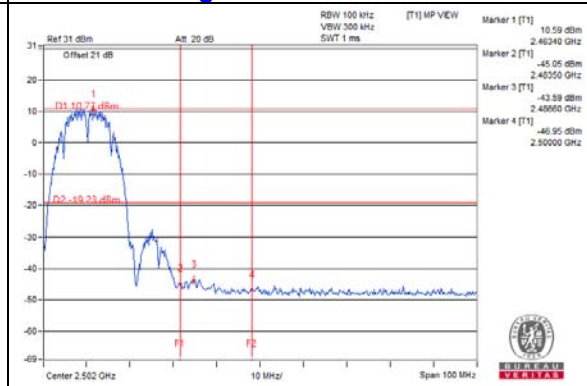

CH 12 Band edge

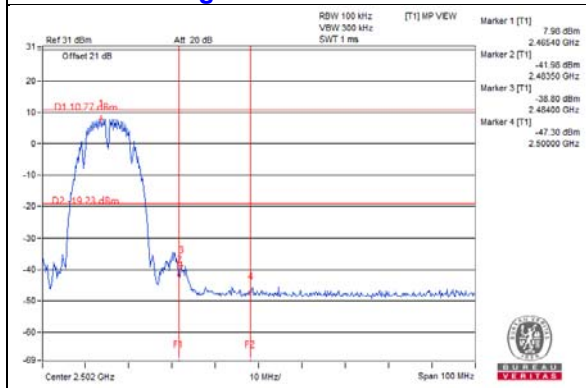

CH 13 Band edge

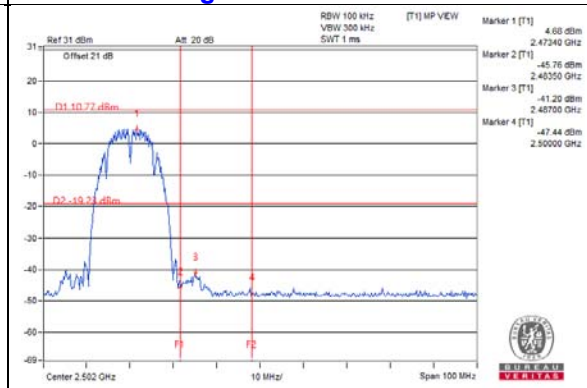

802.11g

Maximum REF

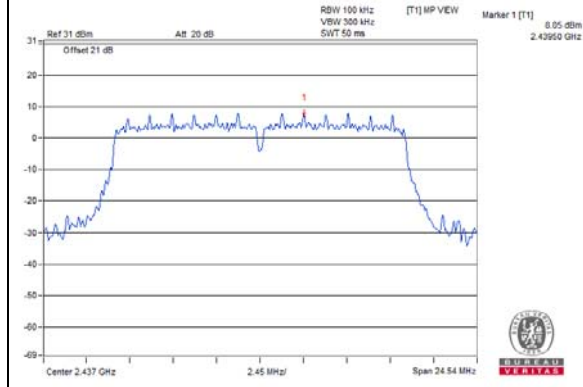

CH 1

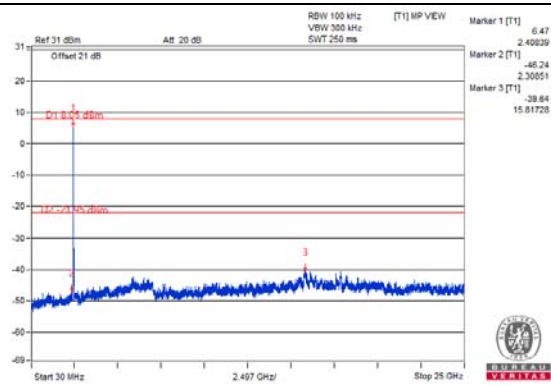

CH 6

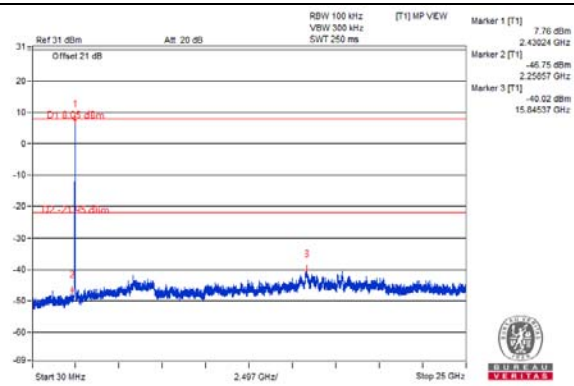

CH 11

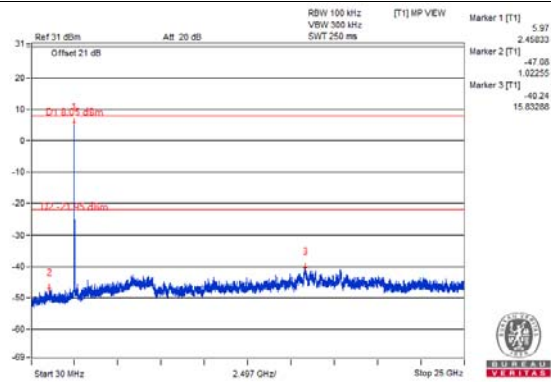

CH 12

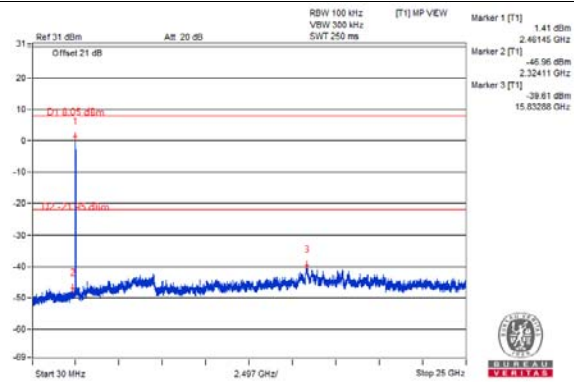

CH 13

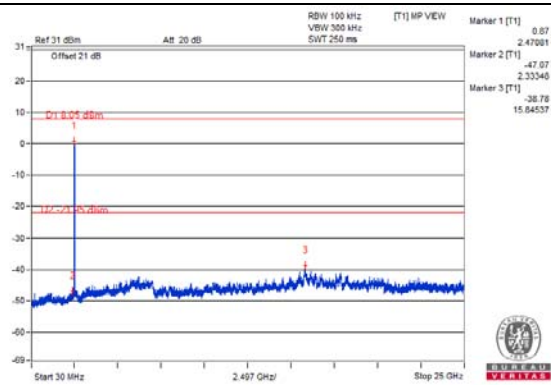

CH 1 Band edge

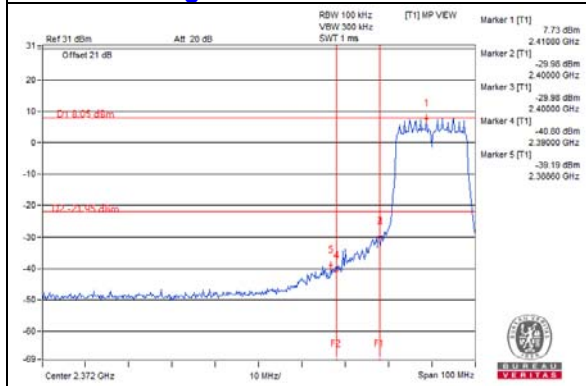

CH 11 Band edge

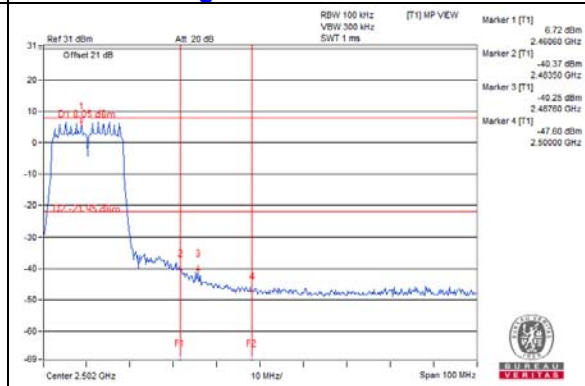

CH 12 Band edge

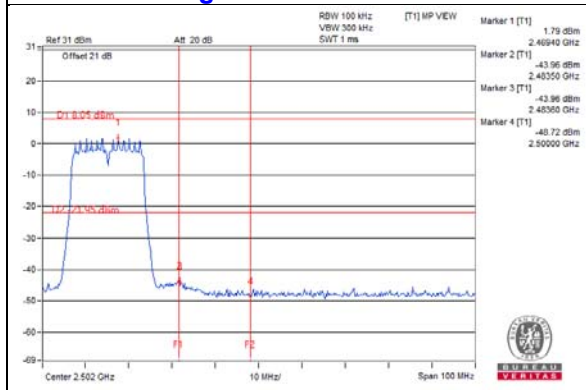

CH 13 Band edge

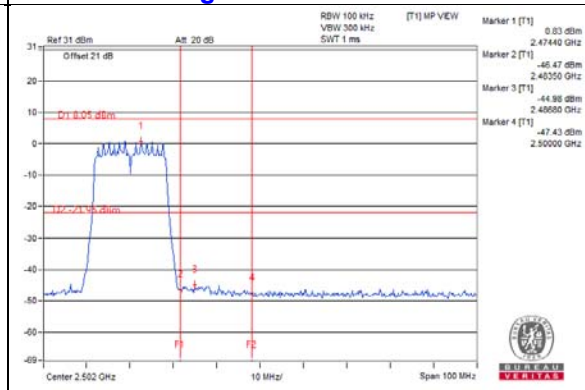

802.11ax (HE20)

Maximum REF

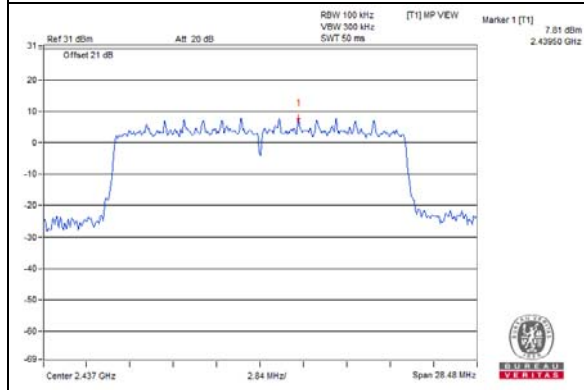

CH 1

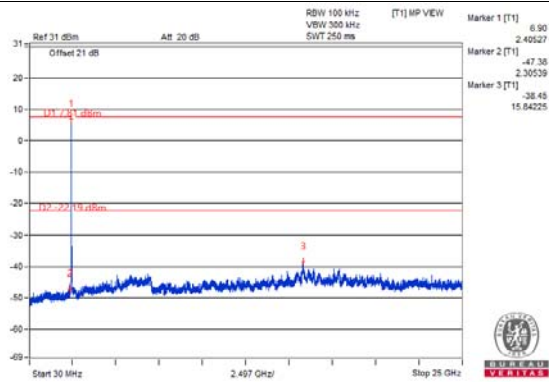

CH 6

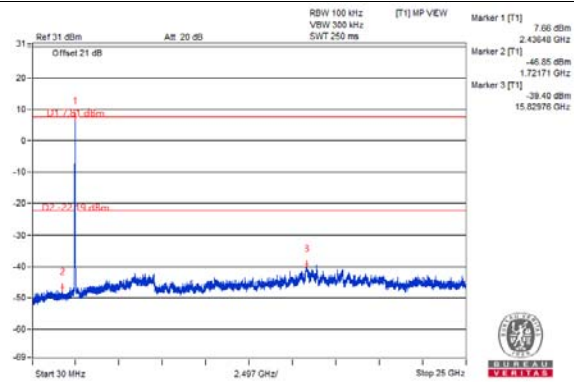

CH 11

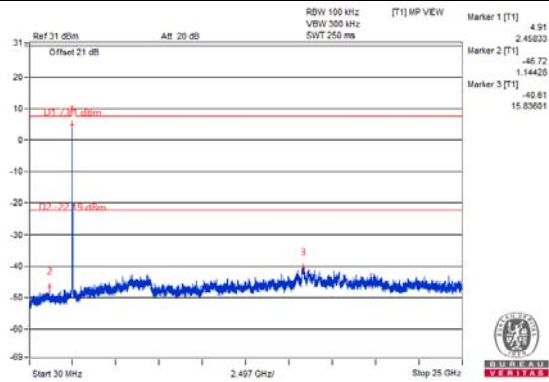

CH 12

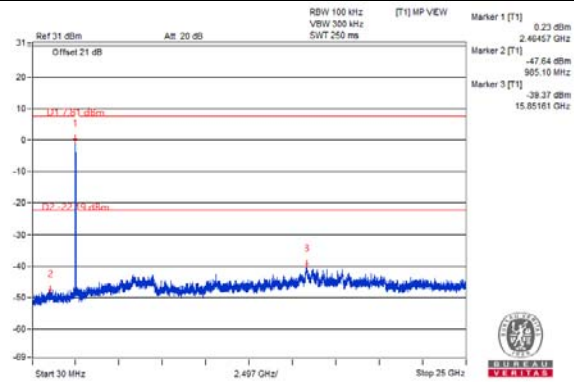

CH 13

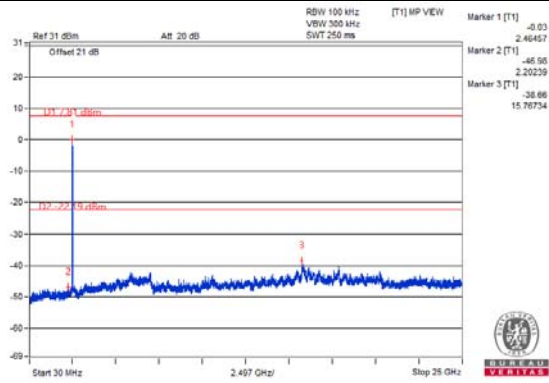

CH 1 Band edge

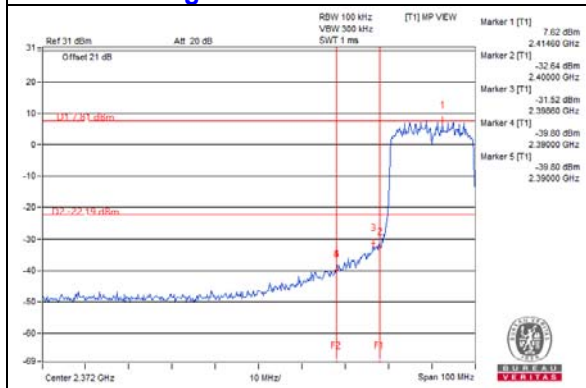

CH 11 Band edge

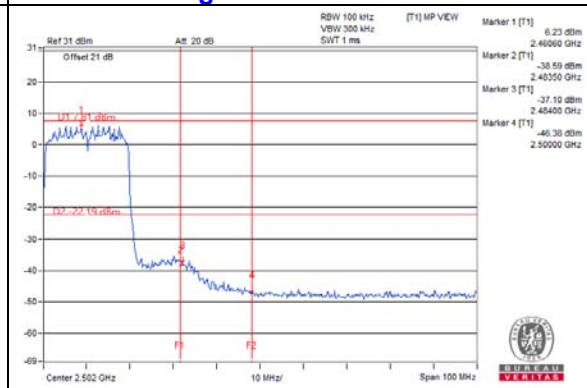

CH 12 Band edge

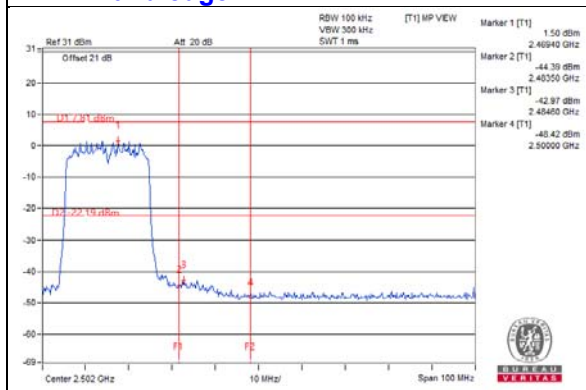

CH 13 Band edge

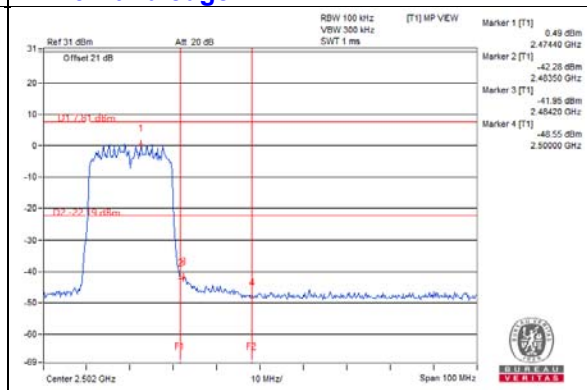

802.11ax (HE40)

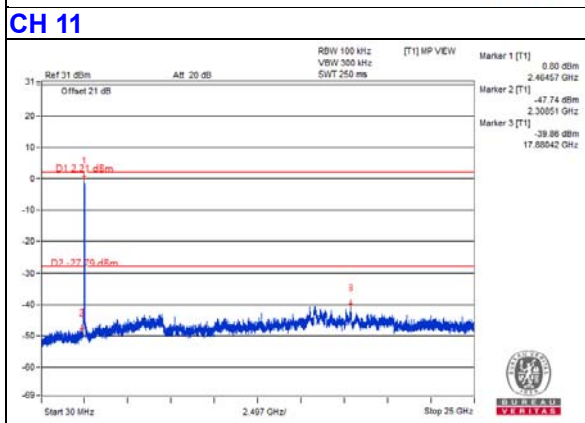
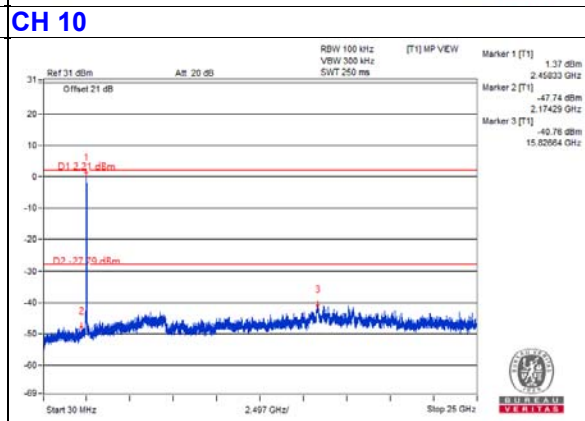
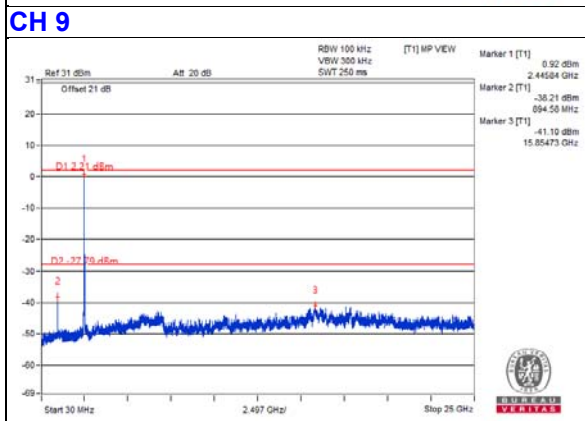
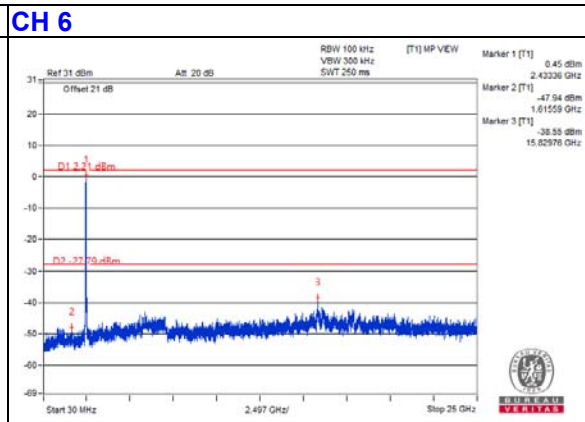
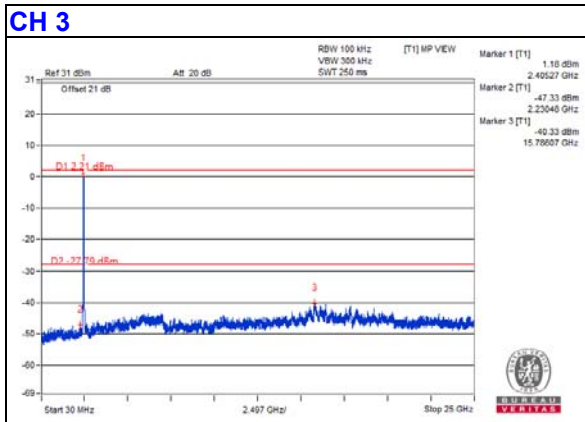
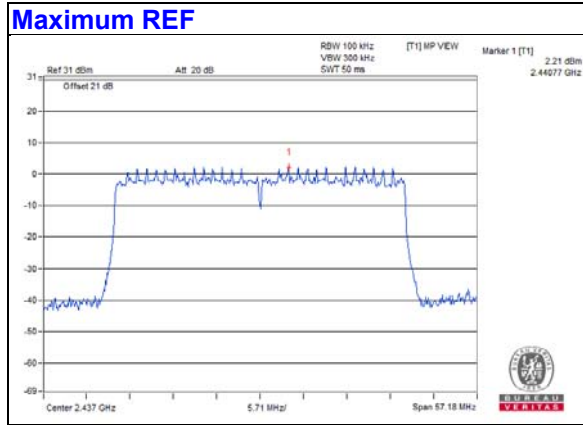

CH 3 Band edge

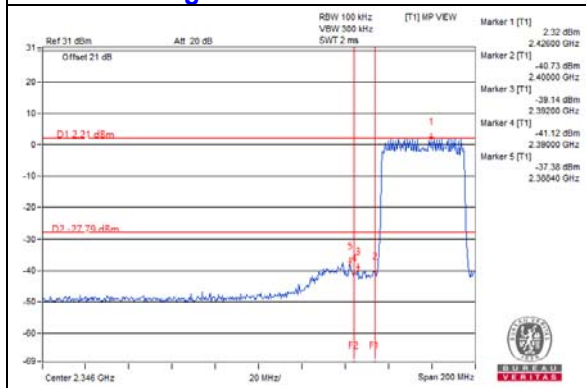

CH 9 Band edge

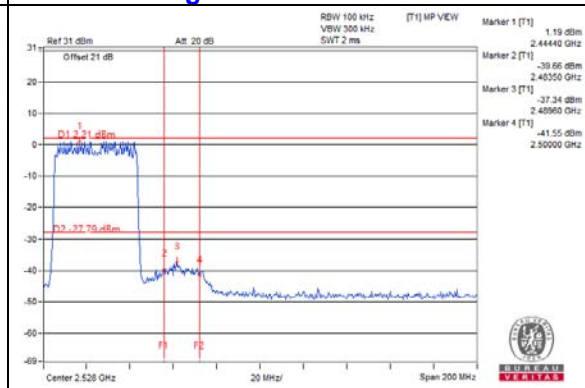

CH 10 Band edge

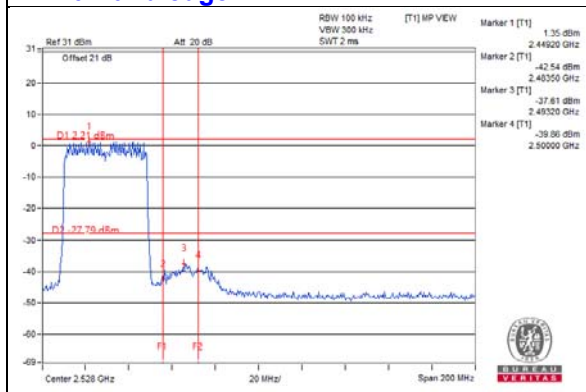

CH 11 Band edge

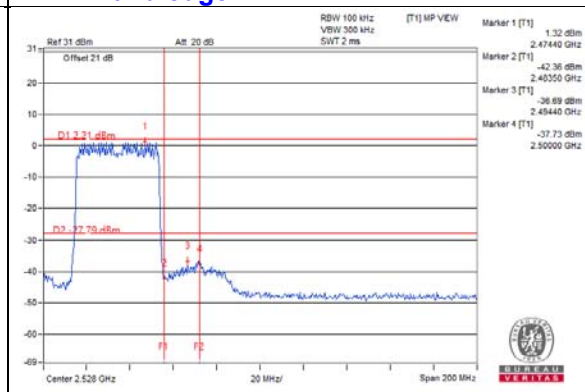

802.11ax (RU26)

Maximum REF

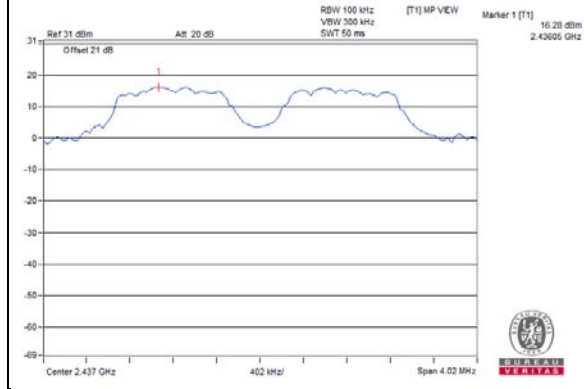

CH 1

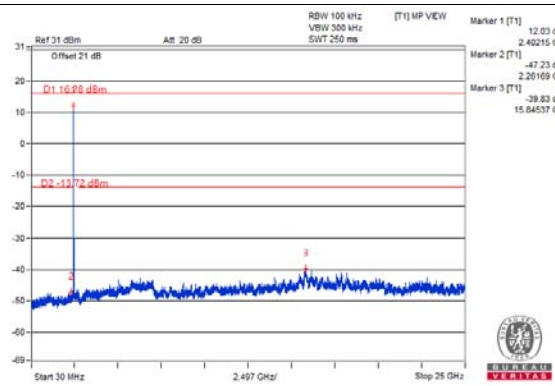

CH 6

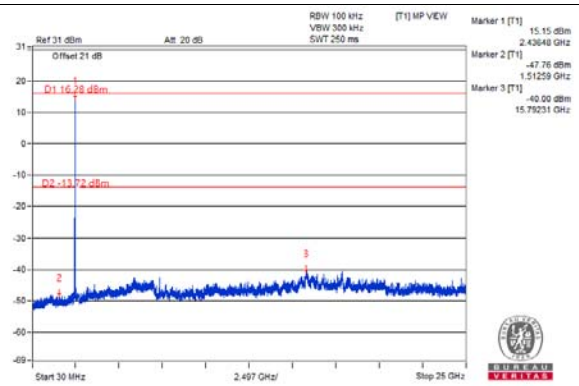

CH 11

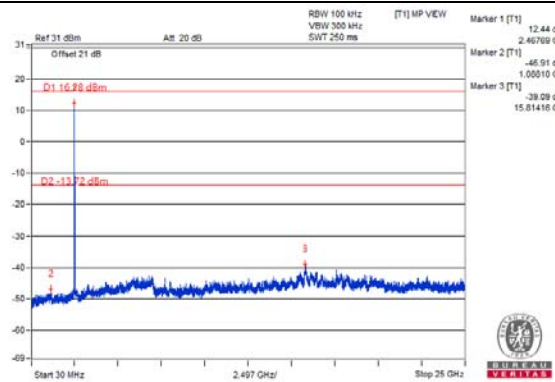

CH 12

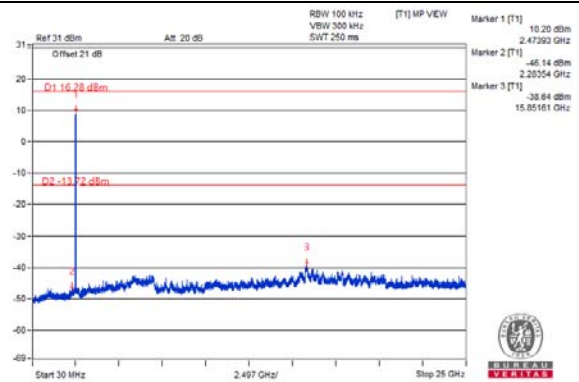

CH 13

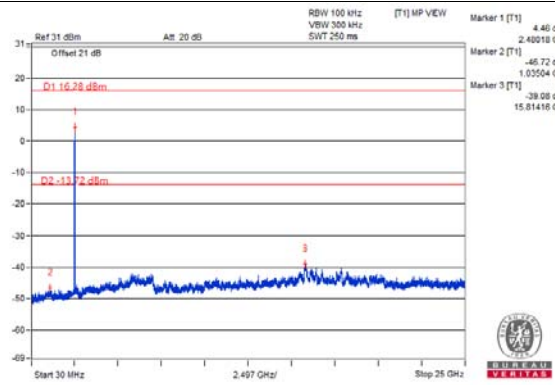

CH 1 Band edge

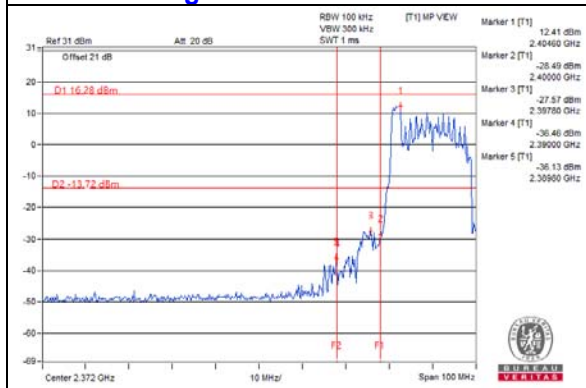

CH 11 Band edge

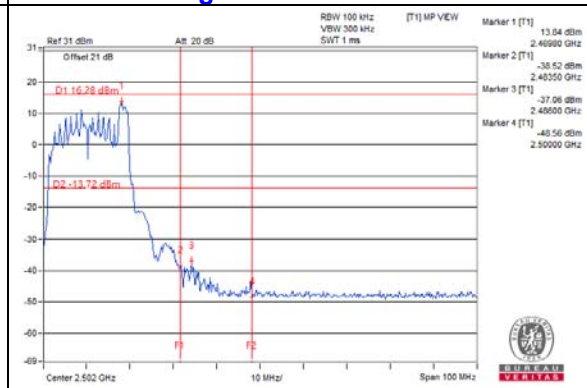

CH 12 Band edge

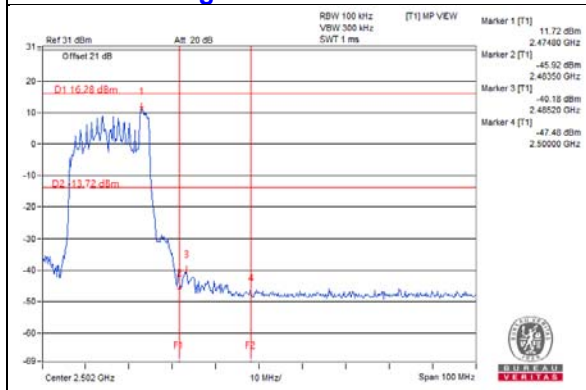

CH 13 Band edge

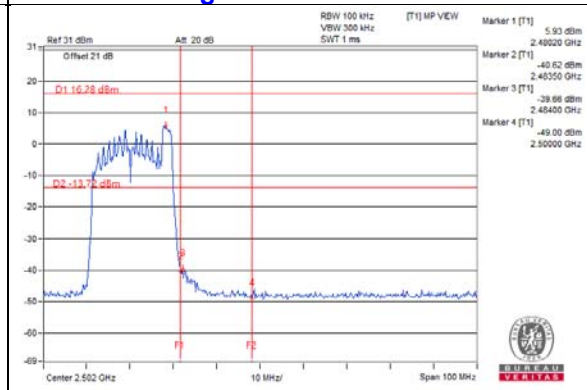

802.11ax (RU52)

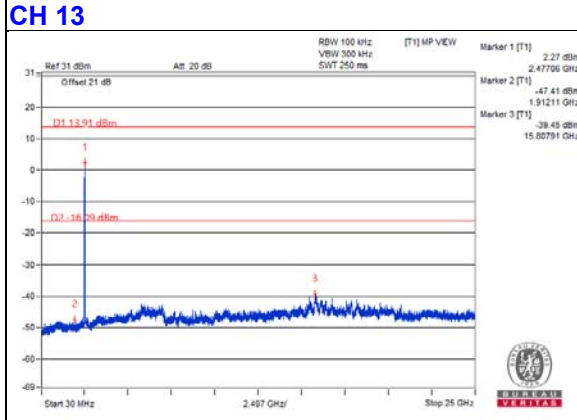
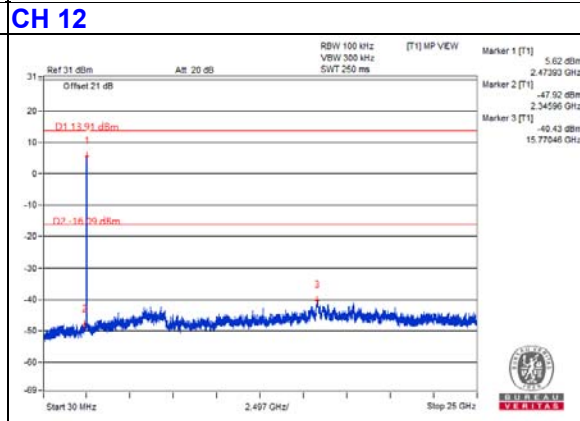
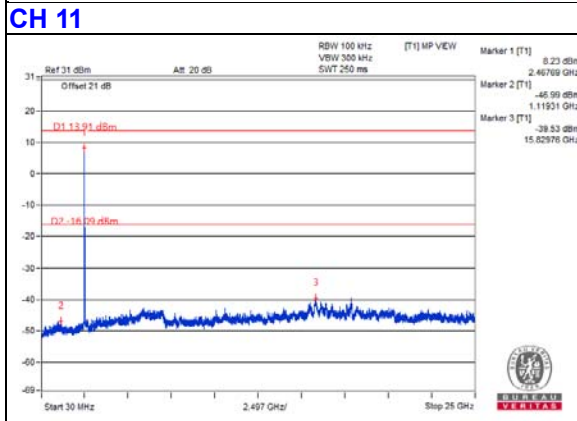
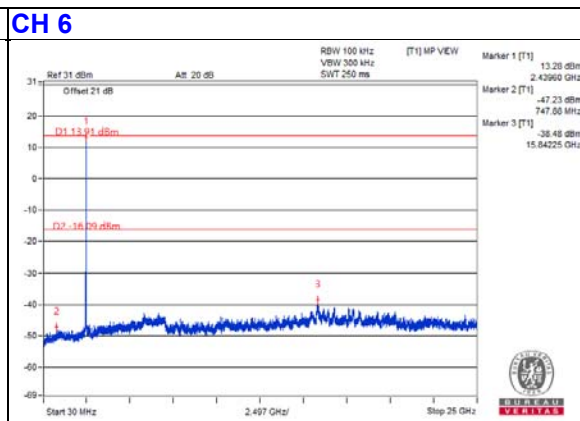
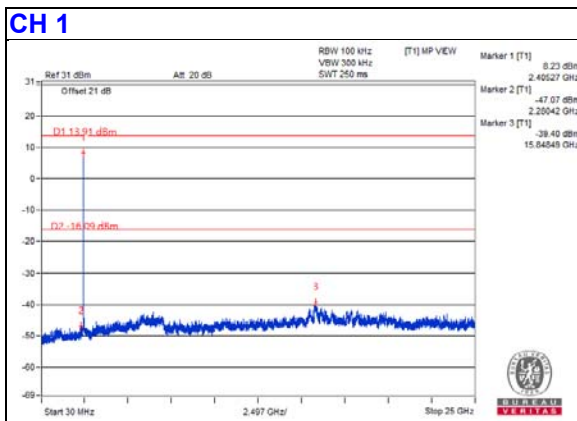
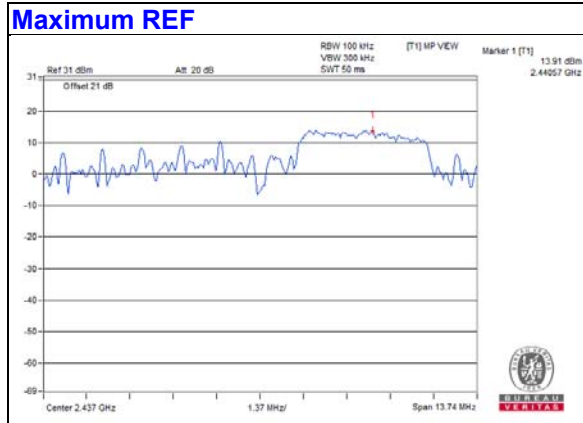

CH 1 Band edge

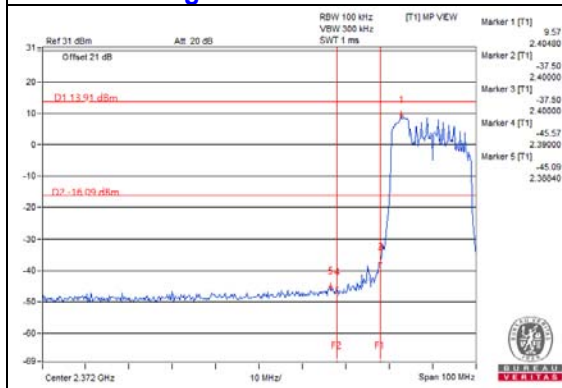

CH 11 Band edge

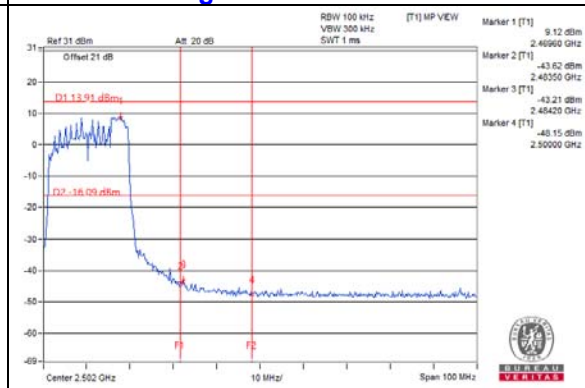

CH 12 Band edge

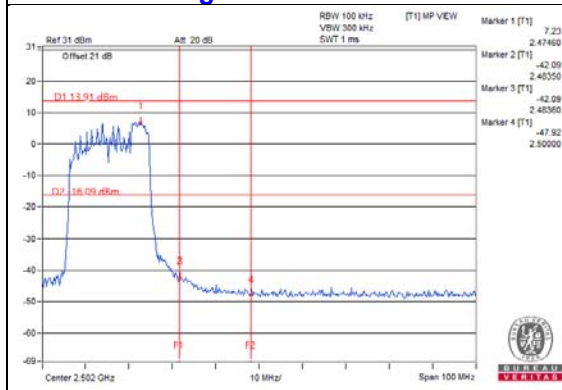

CH 13 Band edge

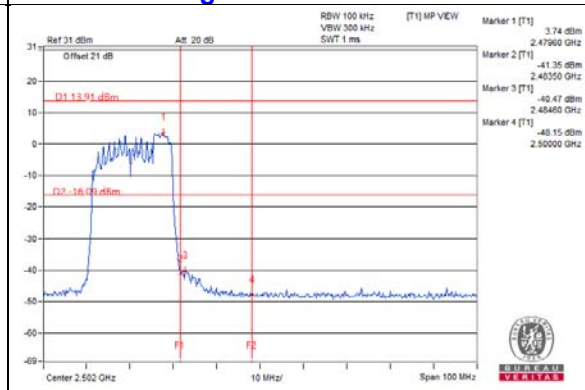

802.11ax (RU106)

Maximum REF

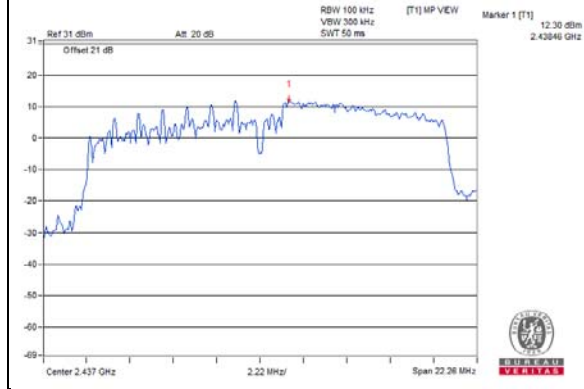

CH 1

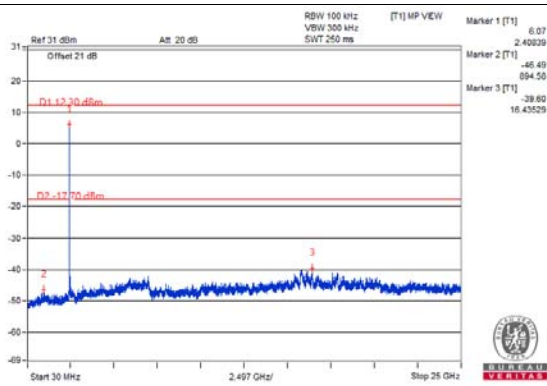

CH 6

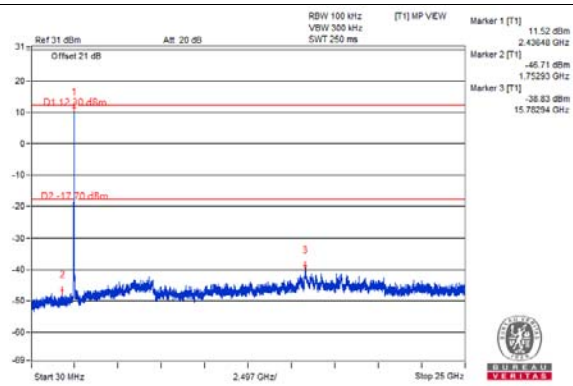

CH 11

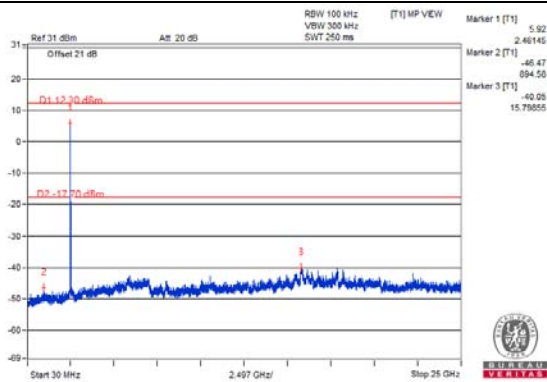

CH 12

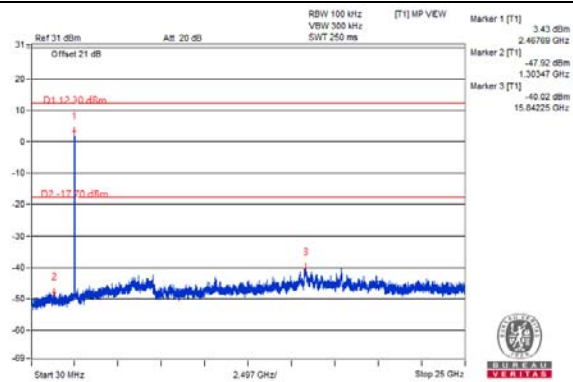

CH 13

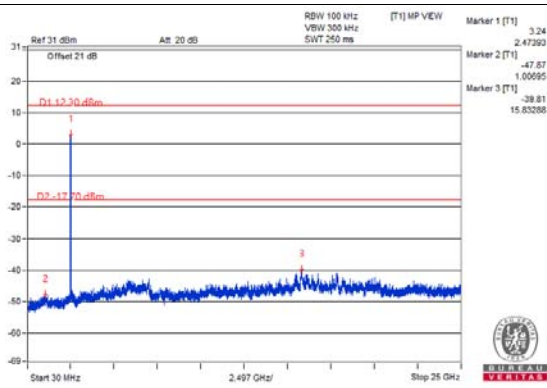

CH 1 Band edge

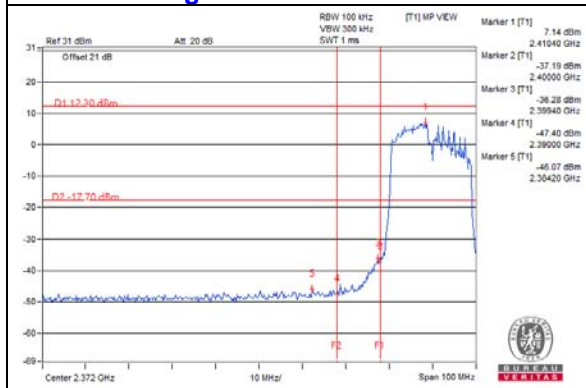

CH 11 Band edge

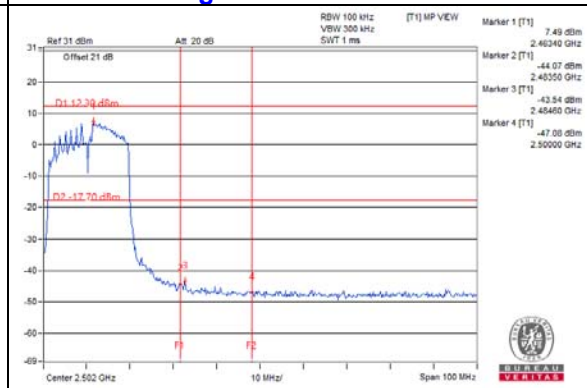

CH 12 Band edge

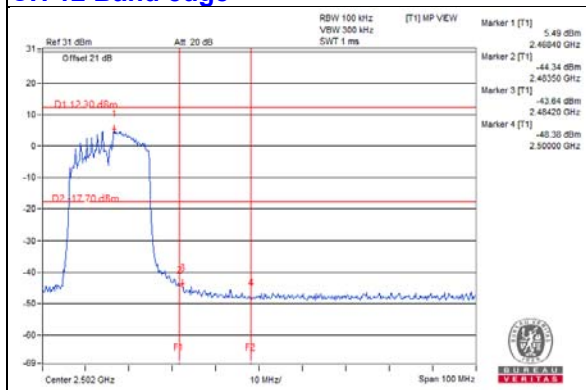

CH 13 Band edge

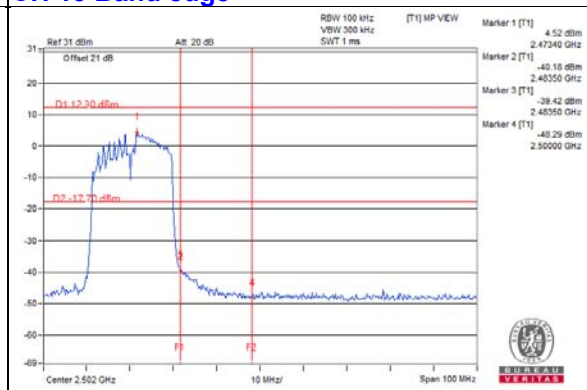

5 Pictures of Test Arrangements

Please refer to the attached file (Test Setup Photo).

Annex A - Band-Edge Measurement

Annex A.1 - Test Results (Mode 1)

Dipole Antenna

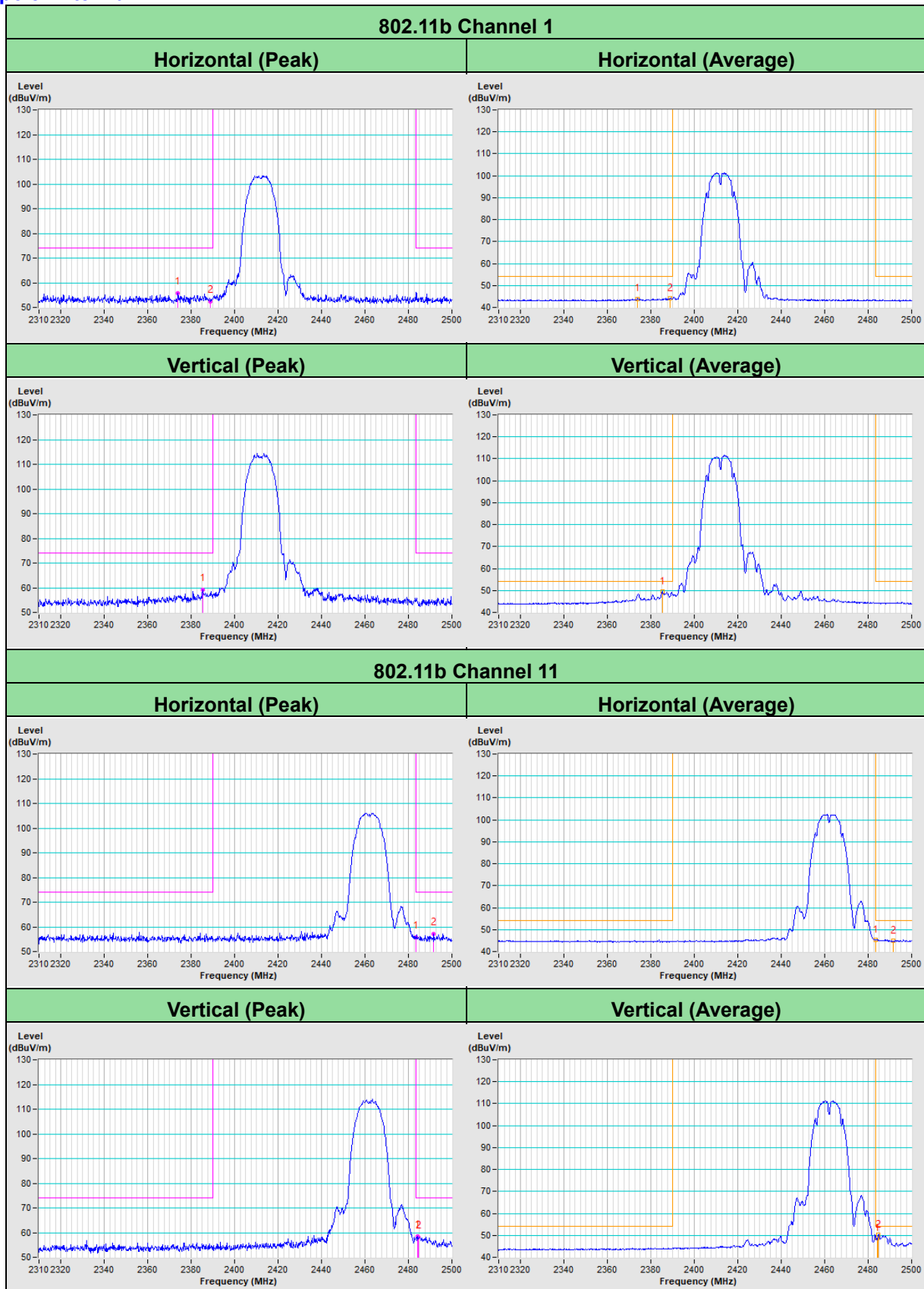

802.11b Channel 12

Horizontal (Peak)	Horizontal (Average)
-------------------	----------------------

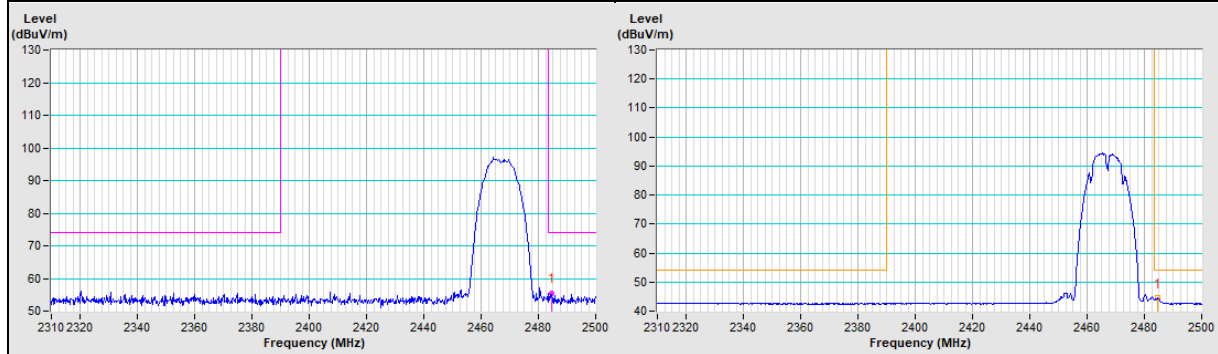

Vertical (Peak)	Vertical (Average)
-----------------	--------------------

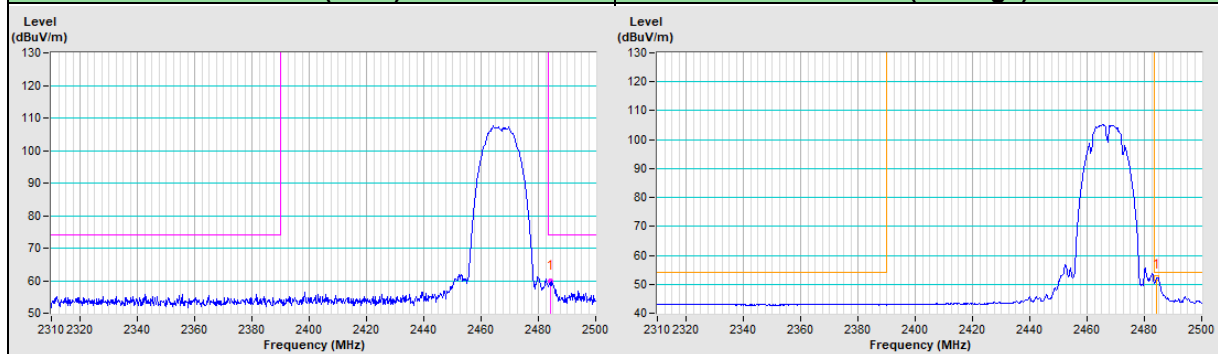

802.11b Channel 13

Horizontal (Peak)	Horizontal (Average)
-------------------	----------------------

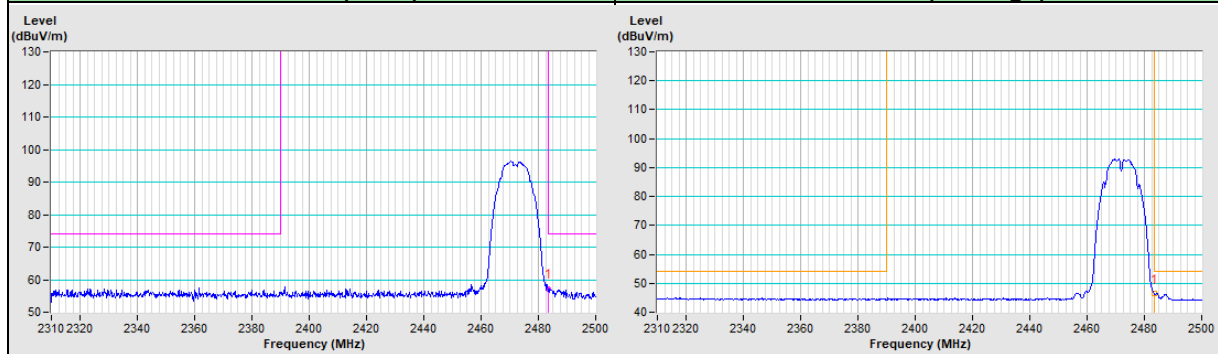

Vertical (Peak)	Vertical (Average)
-----------------	--------------------

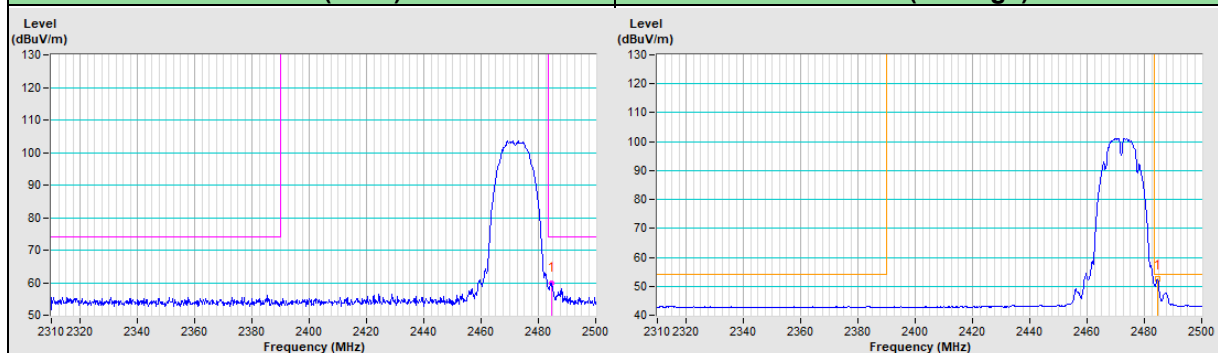

802.11g Channel 1

Horizontal (Peak)	Horizontal (Average)
-------------------	----------------------

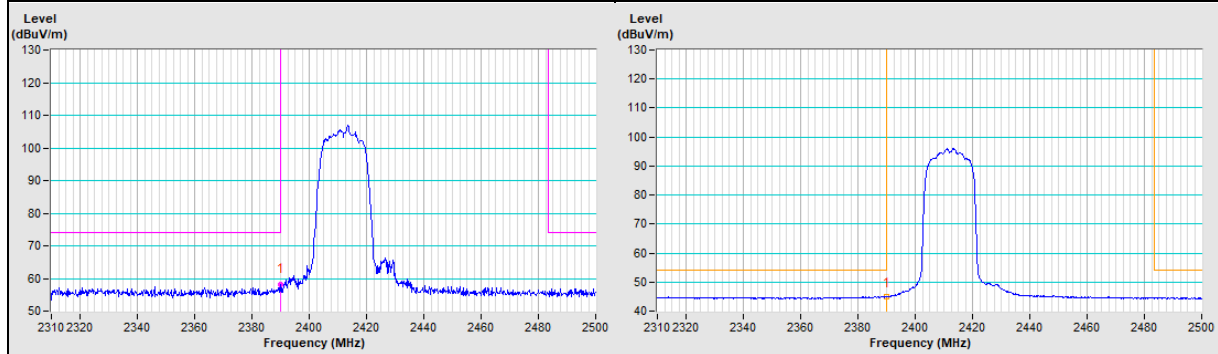

Vertical (Peak)	Vertical (Average)
-----------------	--------------------

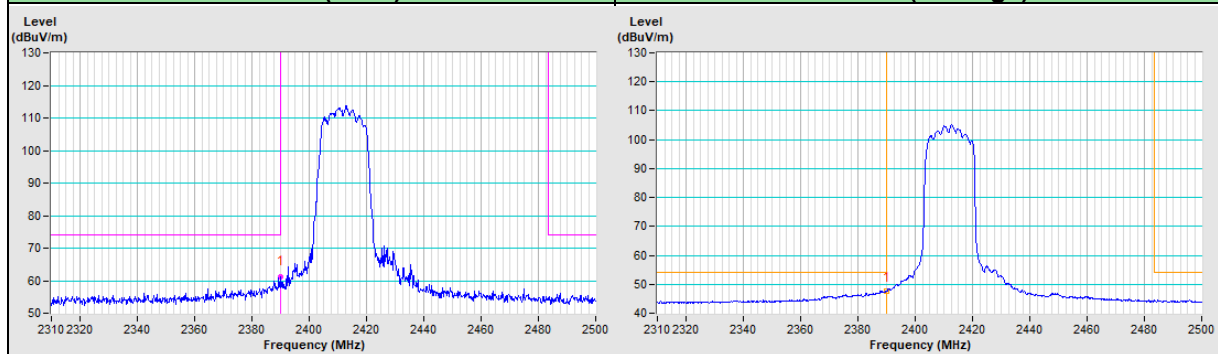

802.11g Channel 11

Horizontal (Peak)	Horizontal (Average)
-------------------	----------------------

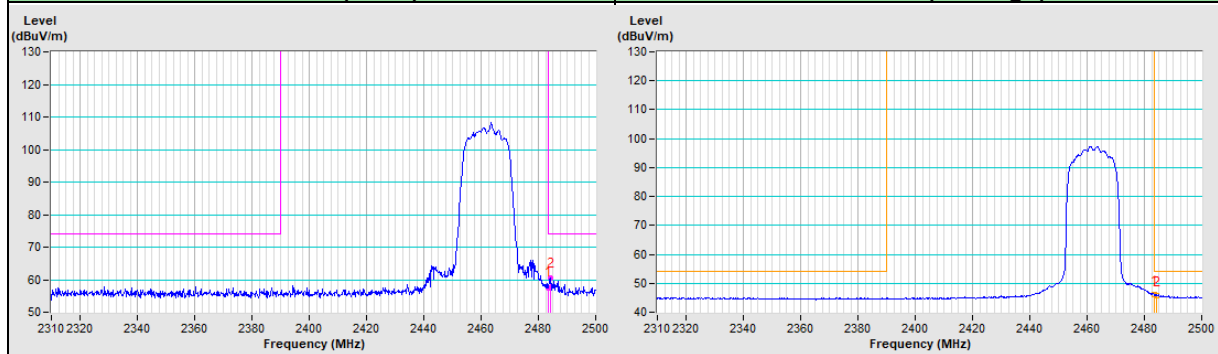

Vertical (Peak)	Vertical (Average)
-----------------	--------------------

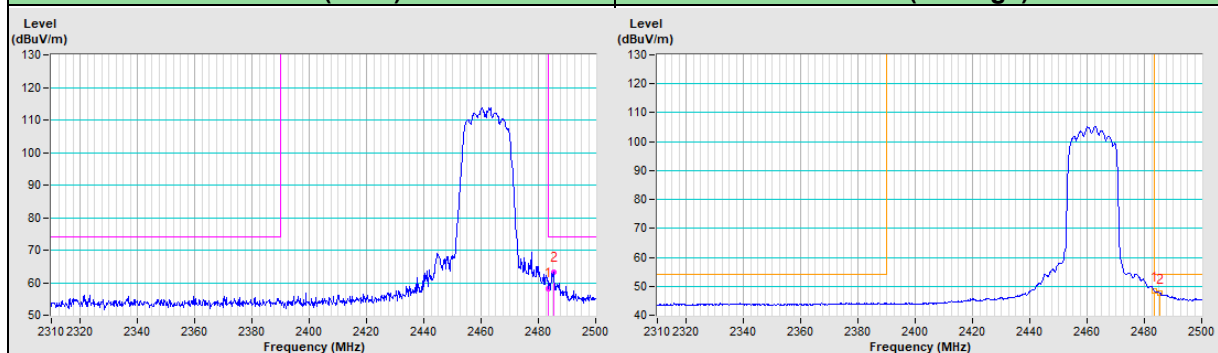

802.11g Channel 12

Horizontal (Peak)	Horizontal (Average)
-------------------	----------------------

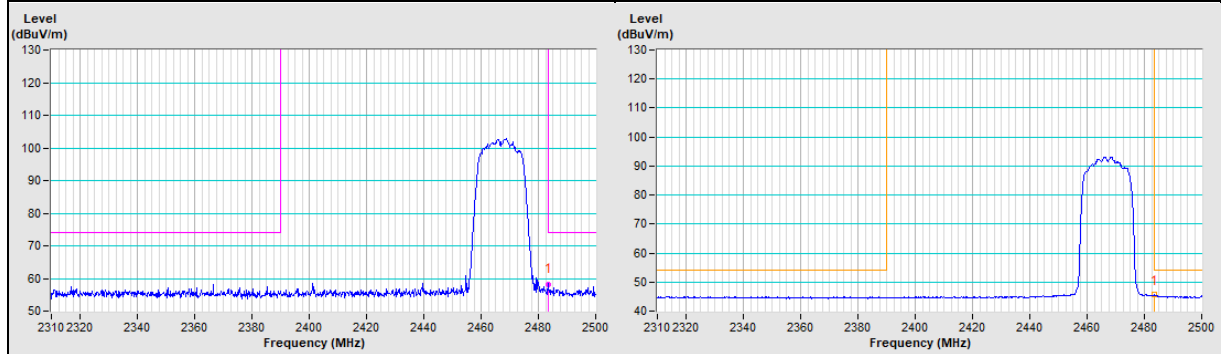

Vertical (Peak)	Vertical (Average)
-----------------	--------------------

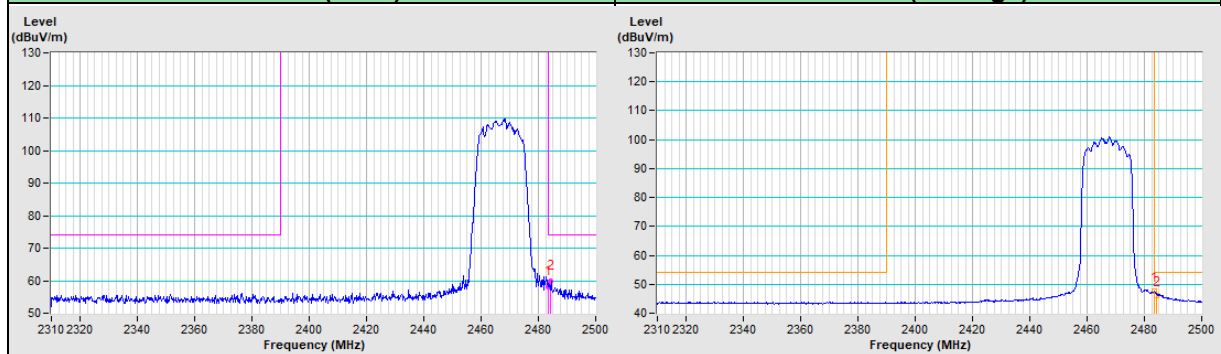

802.11g Channel 13

Horizontal (Peak)	Horizontal (Average)
-------------------	----------------------

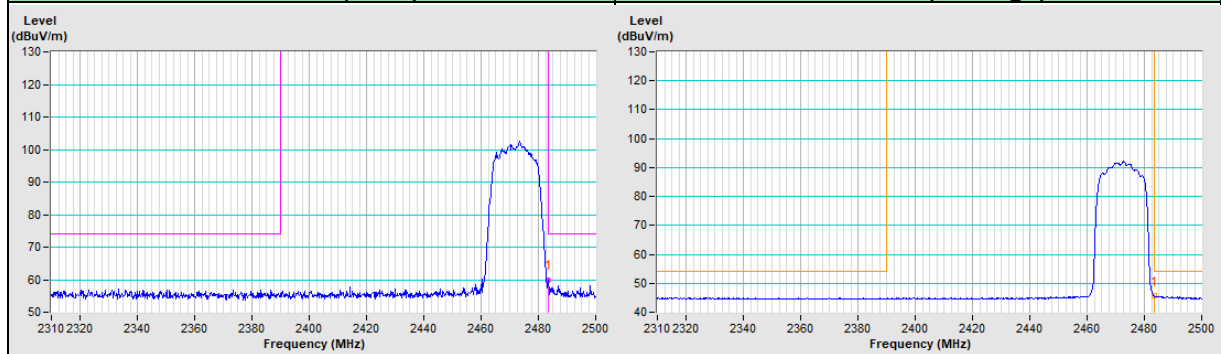

Vertical (Peak)	Vertical (Average)
-----------------	--------------------

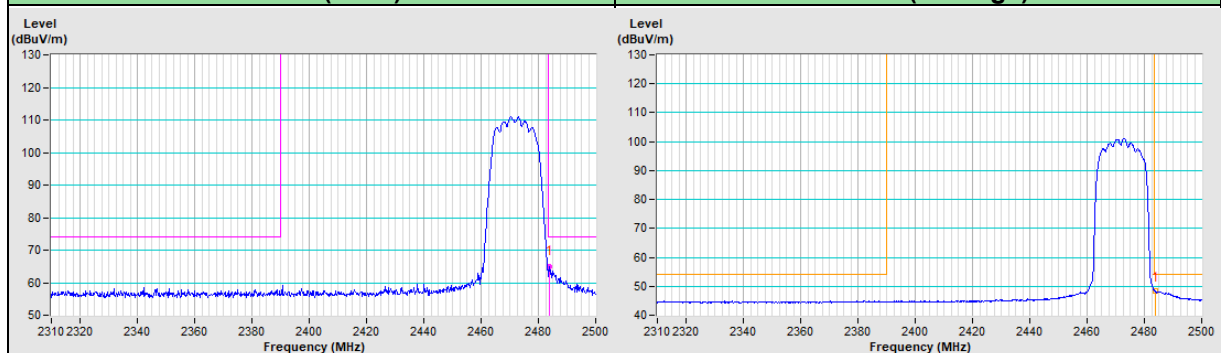

802.11ax (HE20) Channel 1

Horizontal (Peak)

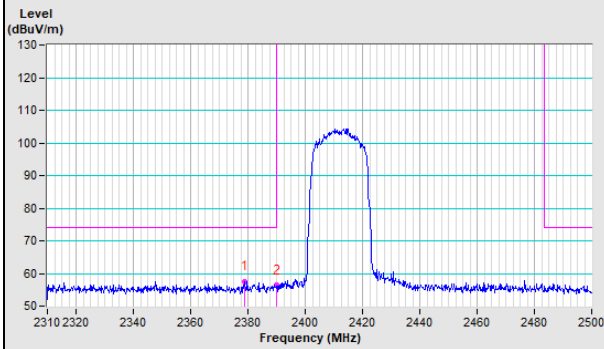

Horizontal (Average)

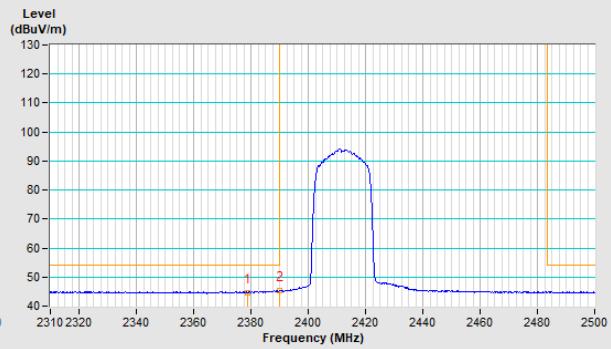

Vertical (Peak)

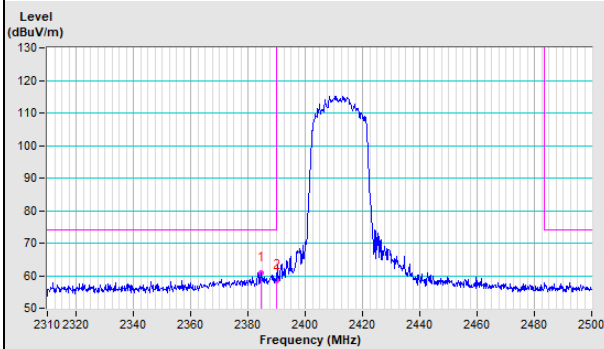

Vertical (Average)

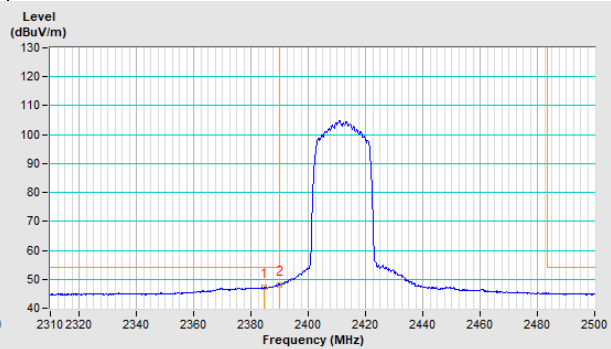

802.11ax (HE20) Channel 11

Horizontal (Peak)

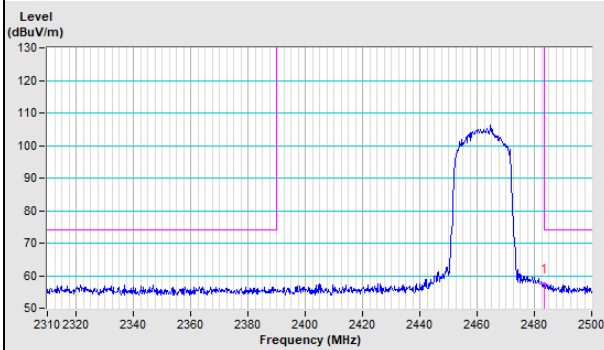

Horizontal (Average)

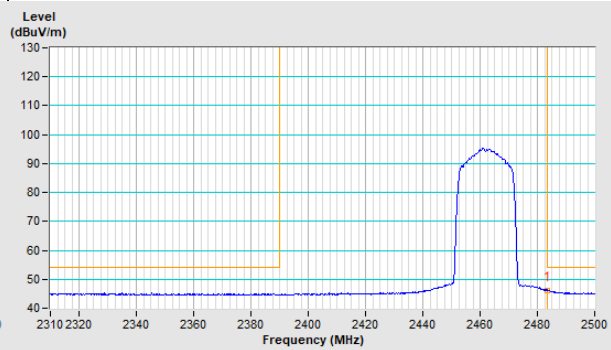

Vertical (Peak)

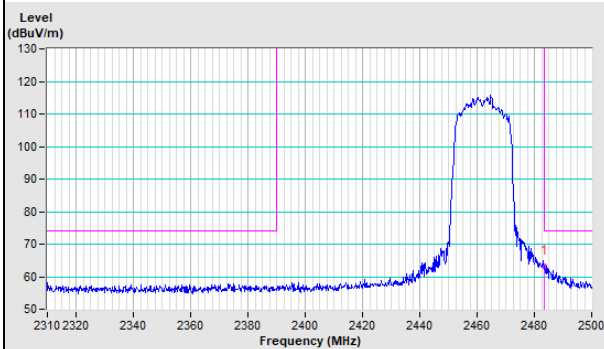

Vertical (Average)

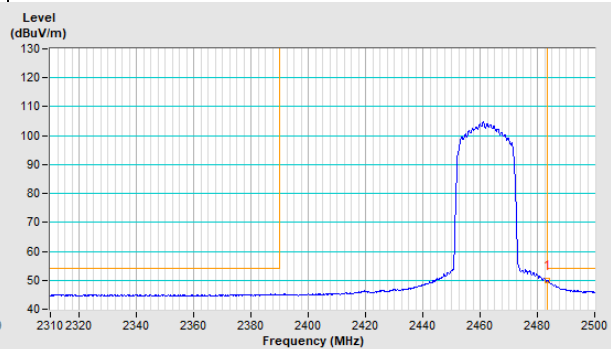

802.11ax (HE20) Channel 12

Horizontal (Peak)	Horizontal (Average)
-------------------	----------------------

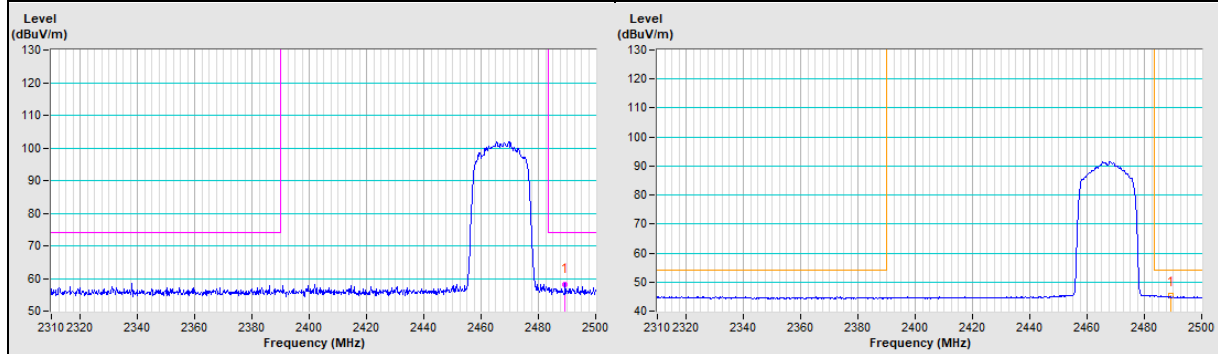

Vertical (Peak)	Vertical (Average)
-----------------	--------------------

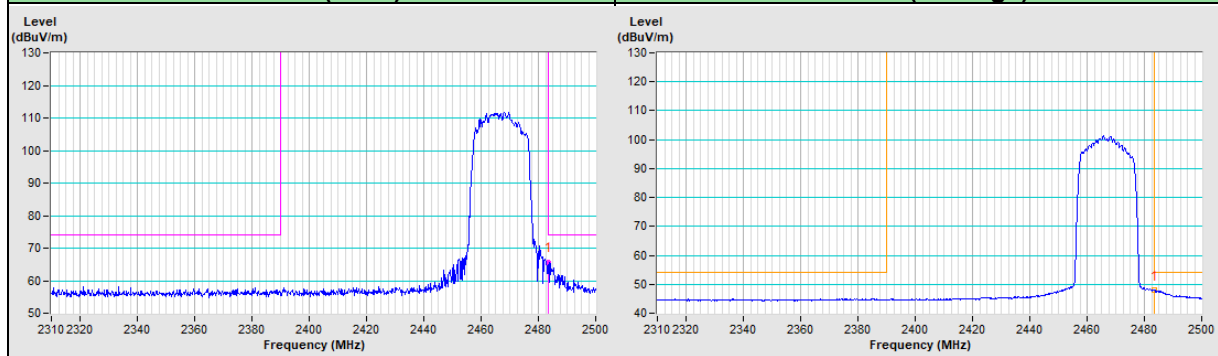

802.11ax (HE20) Channel 13

Horizontal (Peak)	Horizontal (Average)
-------------------	----------------------

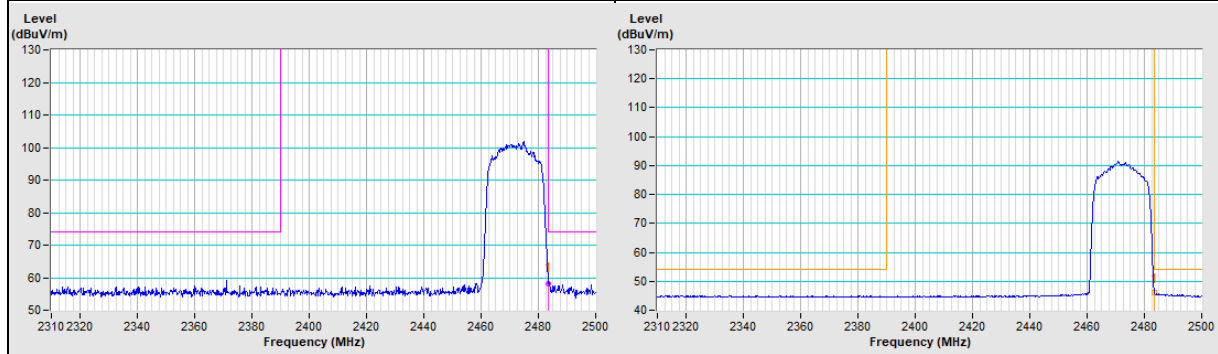

Vertical (Peak)	Vertical (Average)
-----------------	--------------------

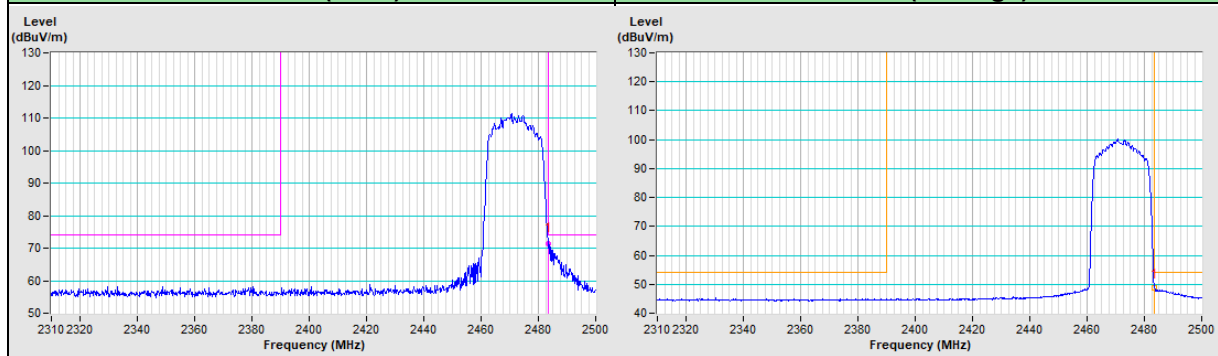

802.11ax (HE40) Channel 3

Horizontal (Peak)	Horizontal (Average)
--------------------------	-----------------------------

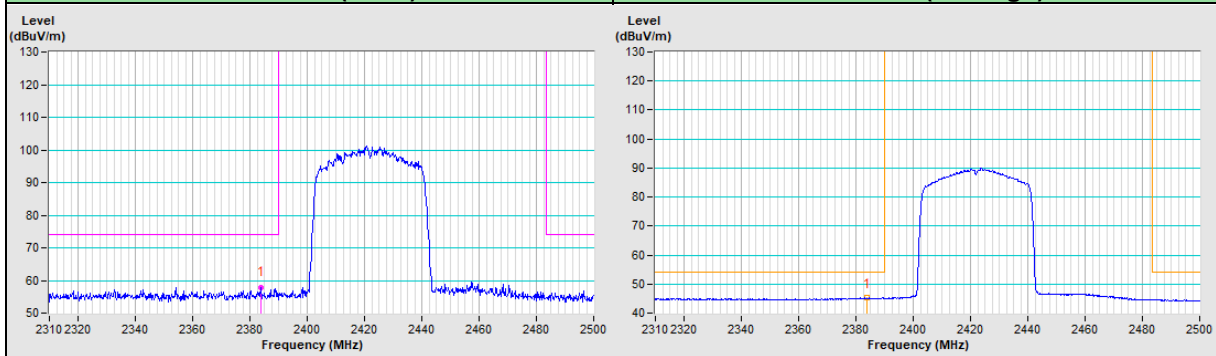

Vertical (Peak)	Vertical (Average)
------------------------	---------------------------

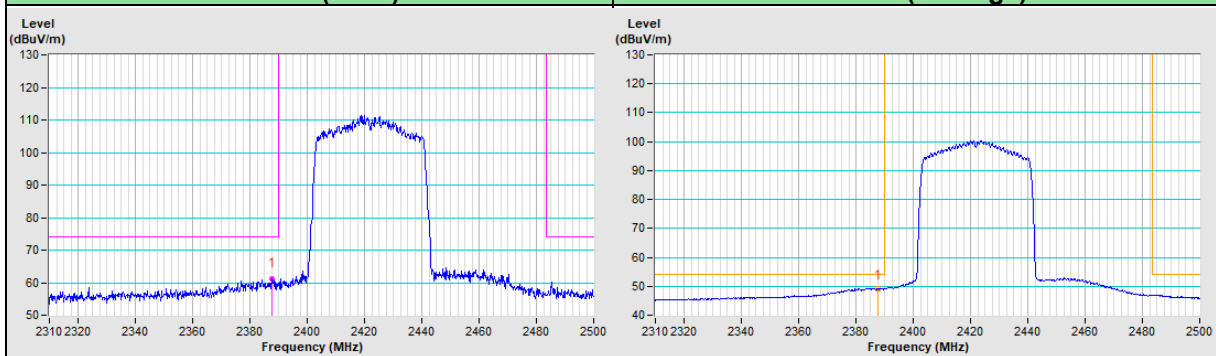

802.11ax (HE40) Channel 9

Horizontal (Peak)	Horizontal (Average)
--------------------------	-----------------------------

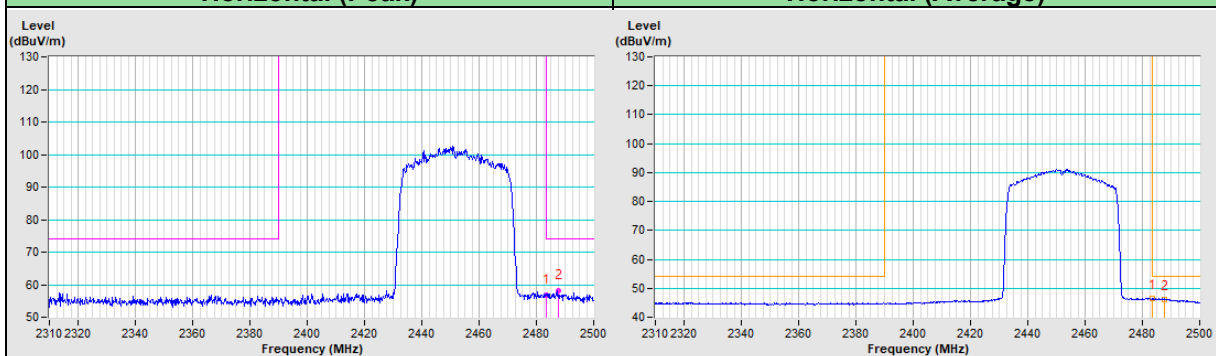

Vertical (Peak)	Vertical (Average)
------------------------	---------------------------

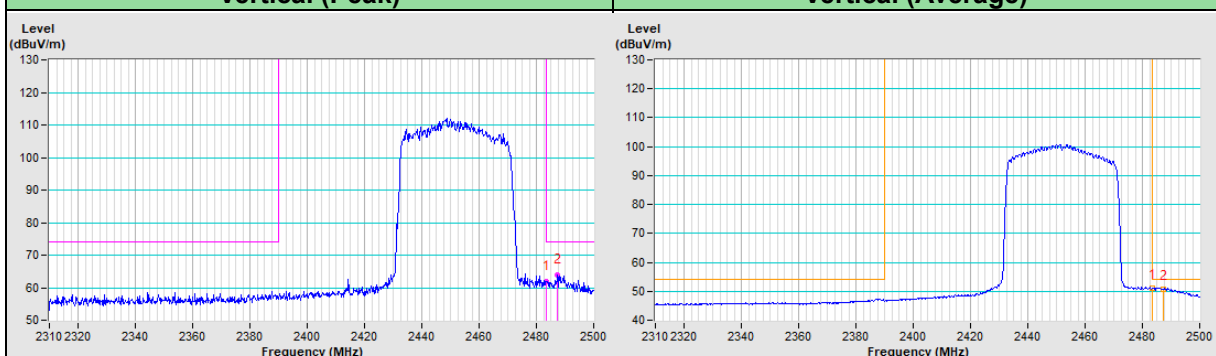

802.11ax (HE40) Channel 10

Horizontal (Peak)	Horizontal (Average)
-------------------	----------------------

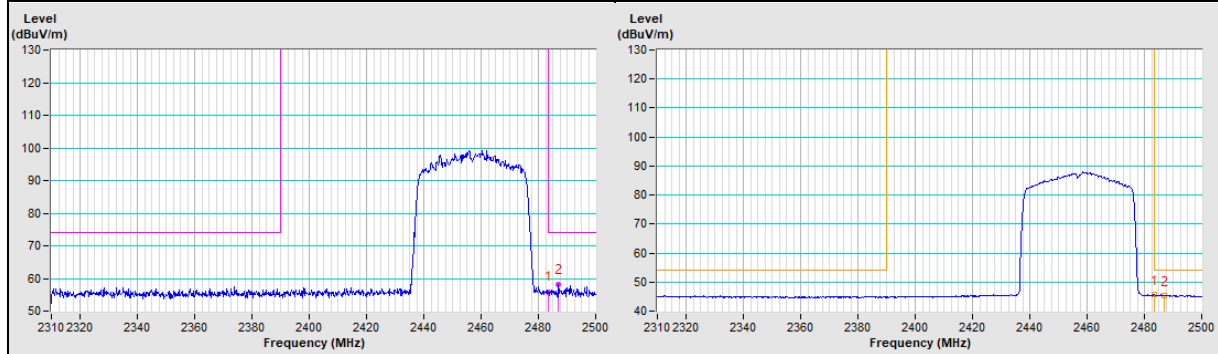

Vertical (Peak)	Vertical (Average)
-----------------	--------------------

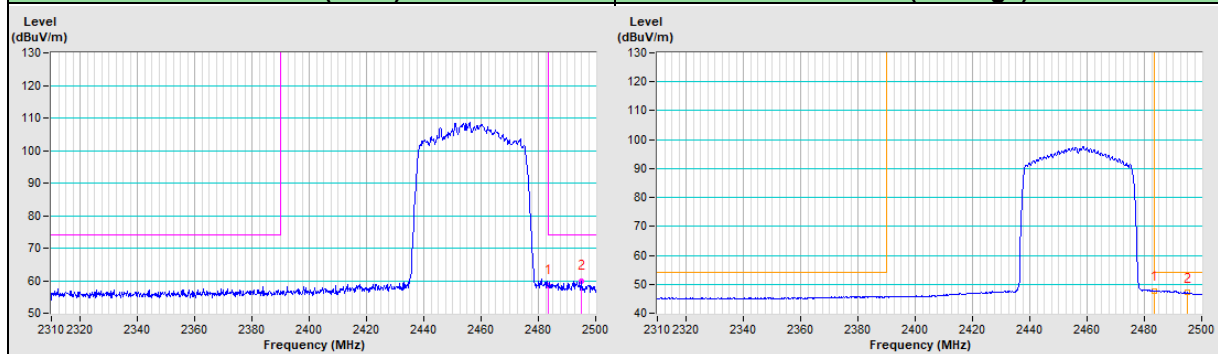

802.11ax (HE40) Channel 11

Horizontal (Peak)	Horizontal (Average)
-------------------	----------------------

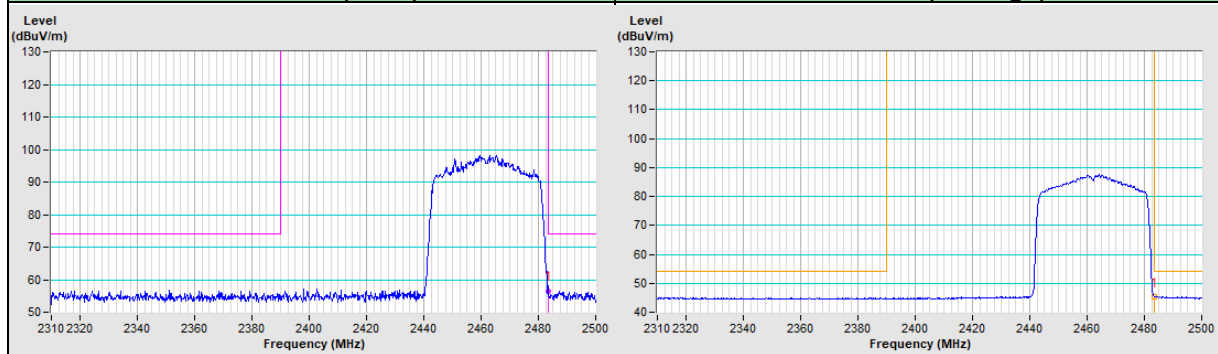

Vertical (Peak)	Vertical (Average)
-----------------	--------------------

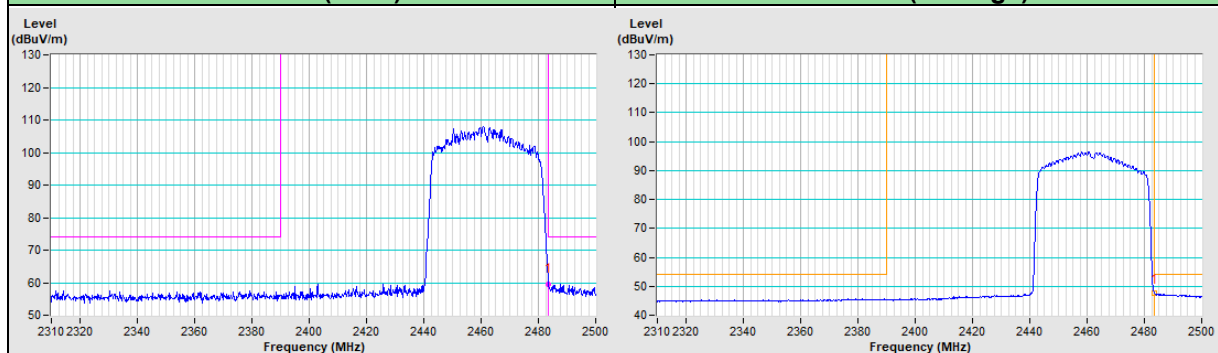

20MHz Preamble 802.11ax (RU26) Channel 1

Horizontal (Peak)	Horizontal (Average)
--------------------------	-----------------------------

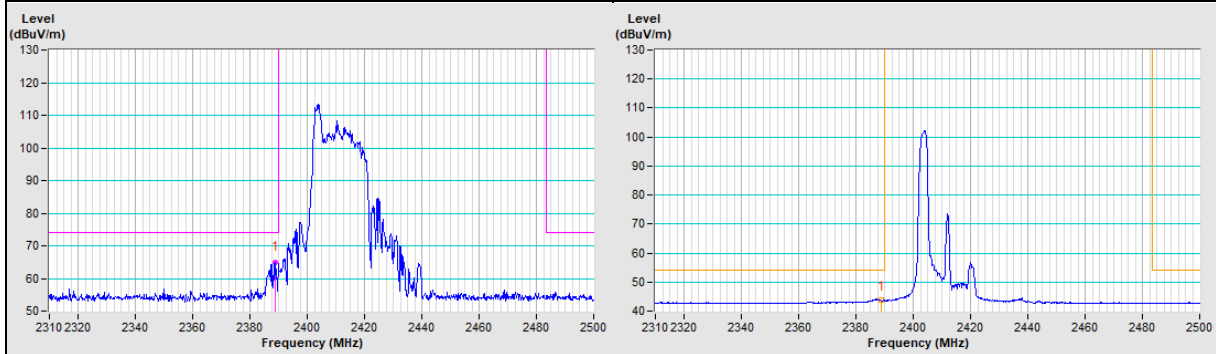

Vertical (Peak)	Vertical (Average)
------------------------	---------------------------

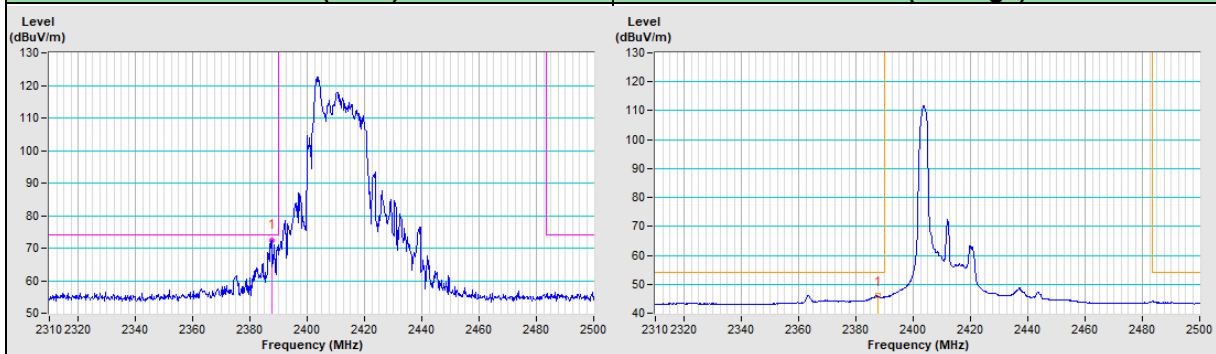

20MHz Preamble 802.11ax (RU26) Channel 11

Horizontal (Peak)	Horizontal (Average)
--------------------------	-----------------------------

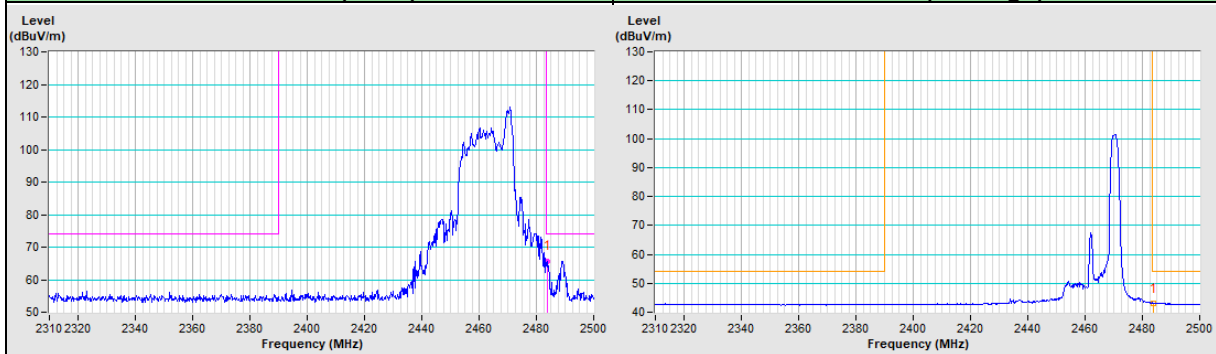

Vertical (Peak)	Vertical (Average)
------------------------	---------------------------

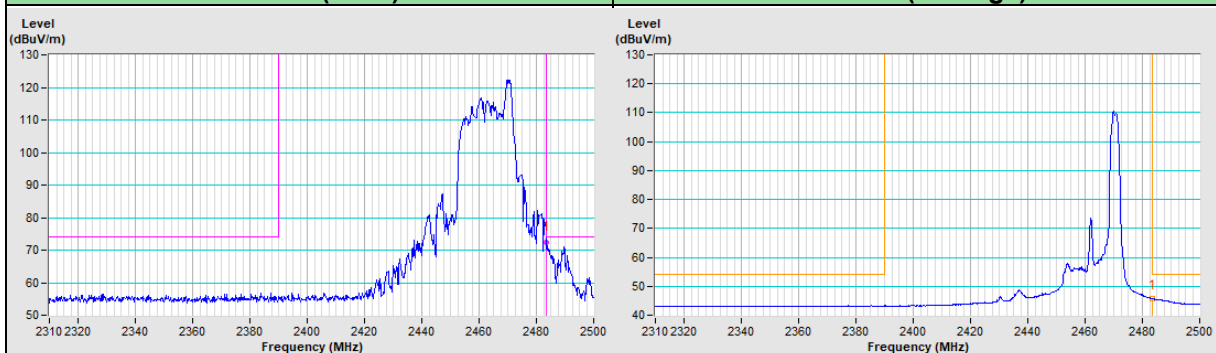

20MHz Preamble 802.11ax (RU26) Channel 12

Horizontal (Peak)

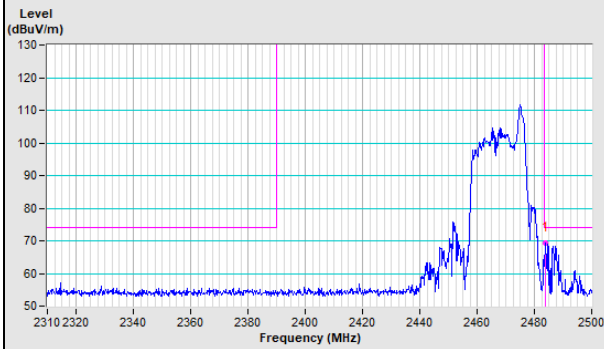

Horizontal (Average)

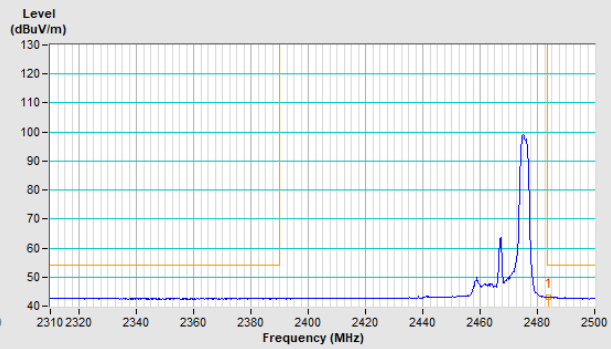

Vertical (Peak)

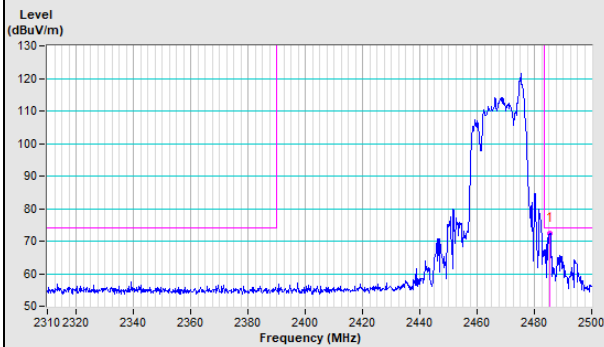

Vertical (Average)

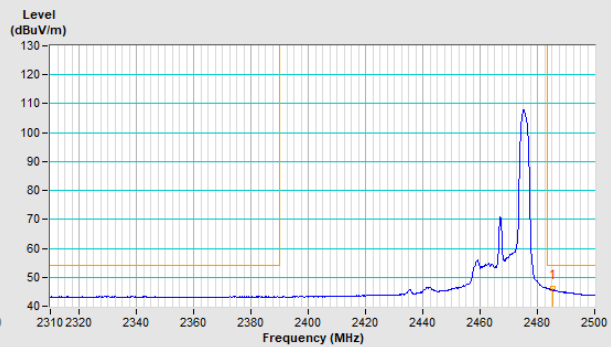

20MHz Preamble 802.11ax (RU26) Channel 13

Horizontal (Peak)

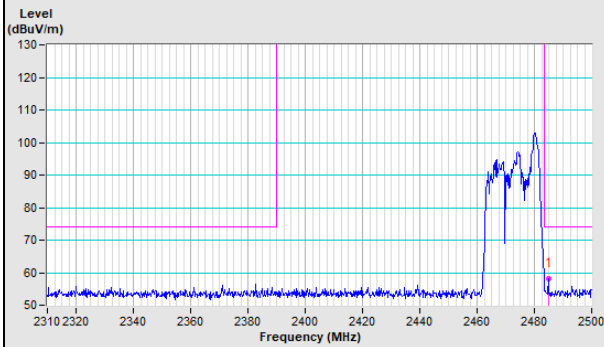

Horizontal (Average)

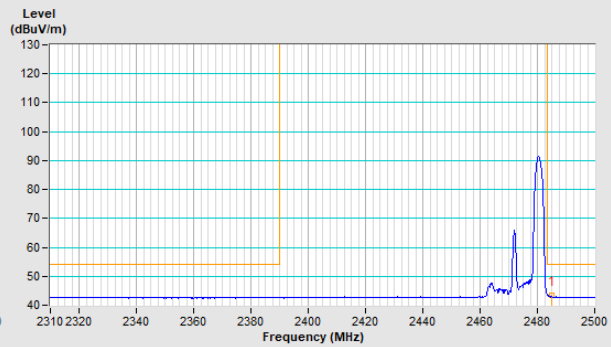

Vertical (Peak)

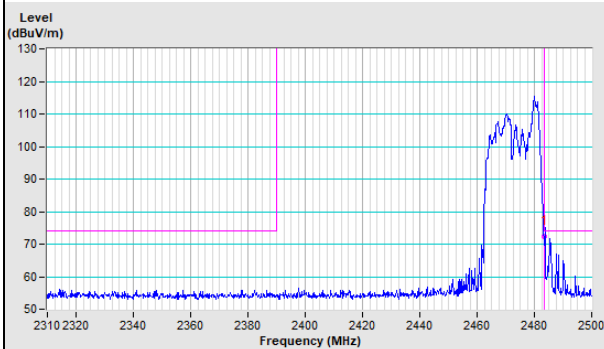

Vertical (Average)

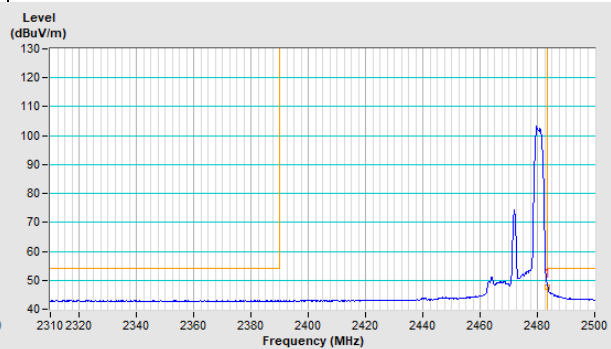

20MHz Preamble 802.11ax (RU52) Channel 1

Horizontal (Peak)	Horizontal (Average)
-------------------	----------------------

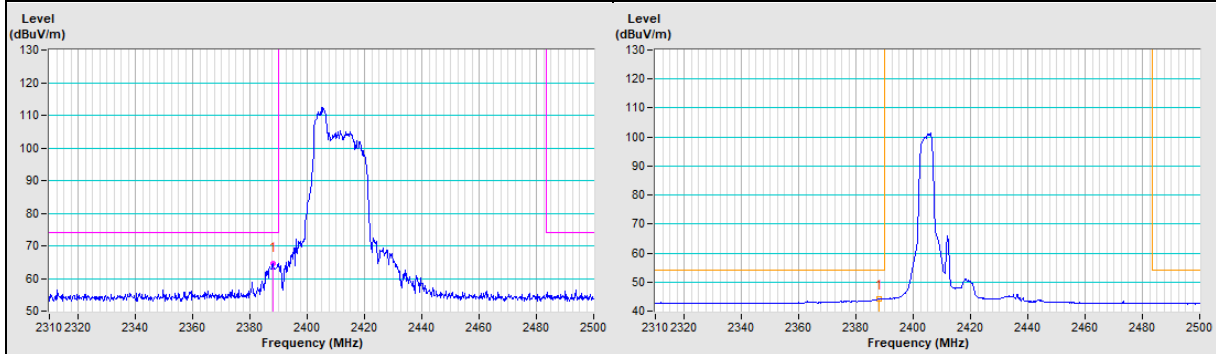

Vertical (Peak)	Vertical (Average)
-----------------	--------------------

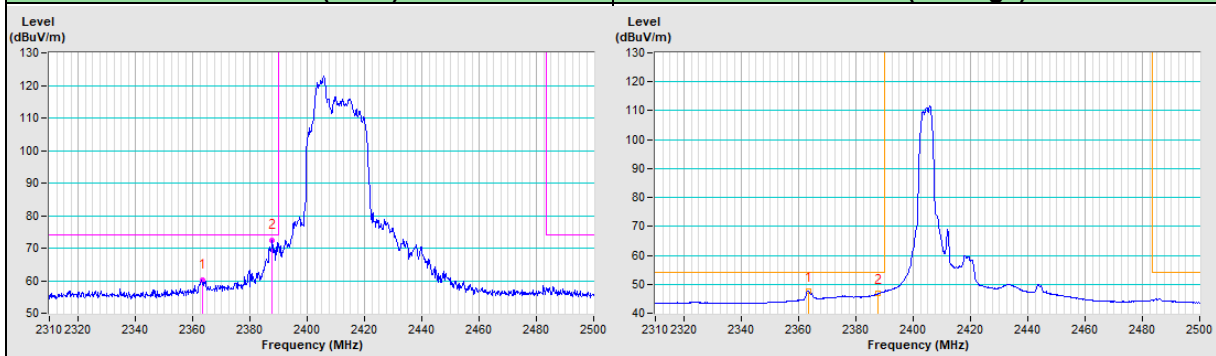

20MHz Preamble 802.11ax (RU52) Channel 11

Horizontal (Peak)	Horizontal (Average)
-------------------	----------------------

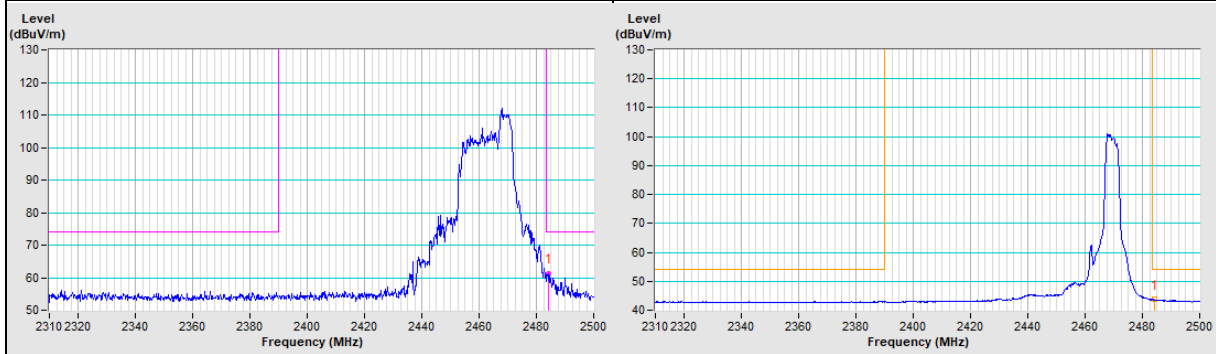

Vertical (Peak)	Vertical (Average)
-----------------	--------------------

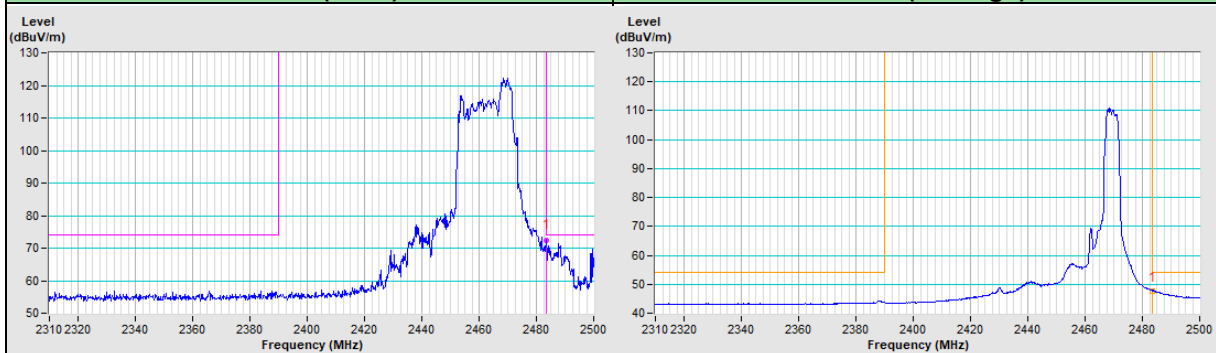

20MHz Preamble 802.11ax (RU52) Channel 12

Horizontal (Peak)

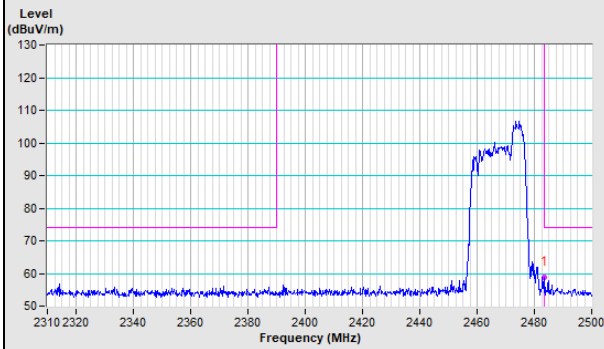

Horizontal (Average)

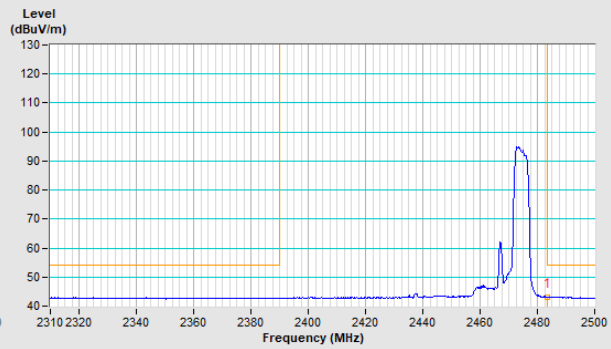

Vertical (Peak)

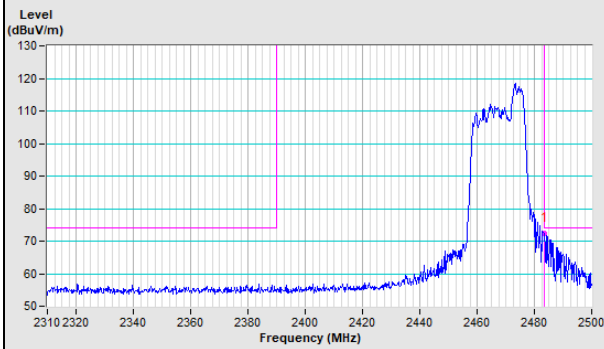

Vertical (Average)

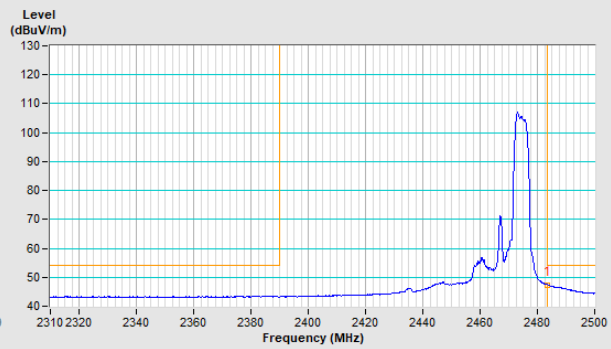

20MHz Preamble 802.11ax (RU52) Channel 13

Horizontal (Peak)

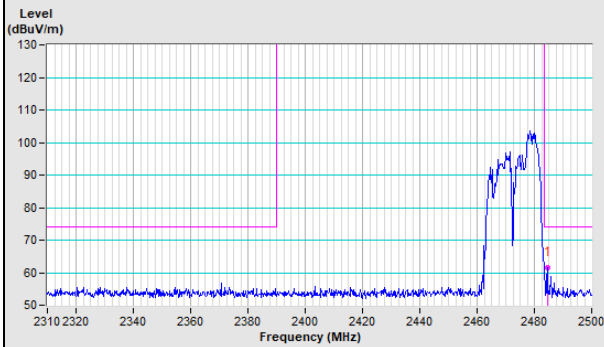

Horizontal (Average)

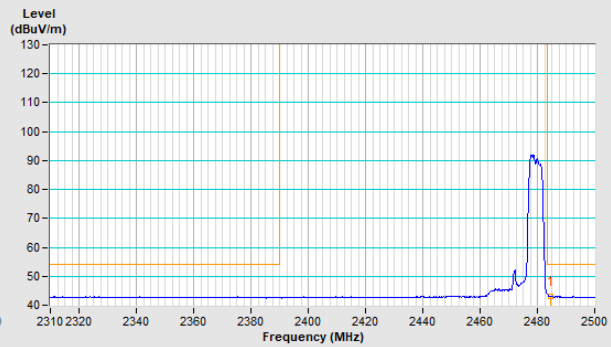

Vertical (Peak)

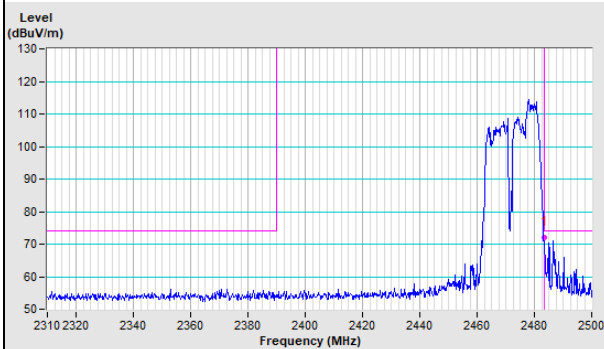

Vertical (Average)

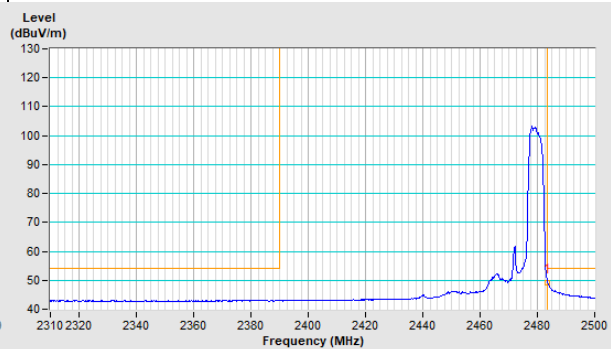

20MHz Preamble 802.11ax (RU106) Channel 1

Horizontal (Peak)	Horizontal (Average)
-------------------	----------------------

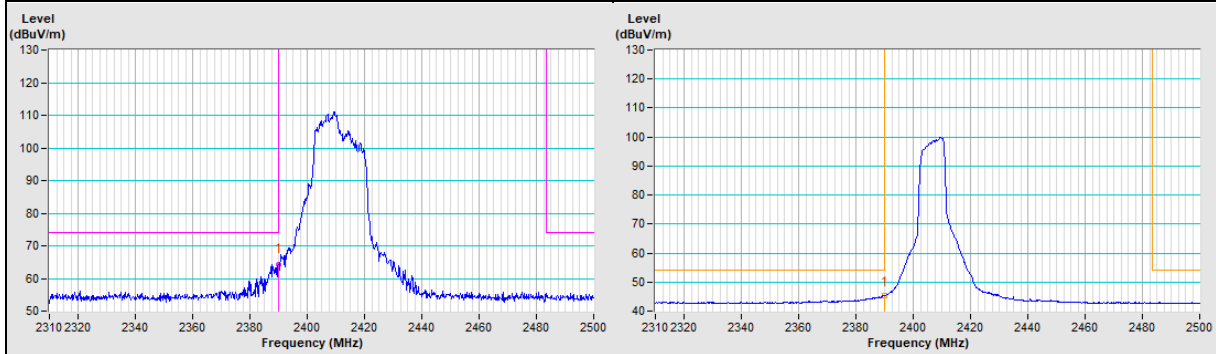

Vertical (Peak)	Vertical (Average)
-----------------	--------------------

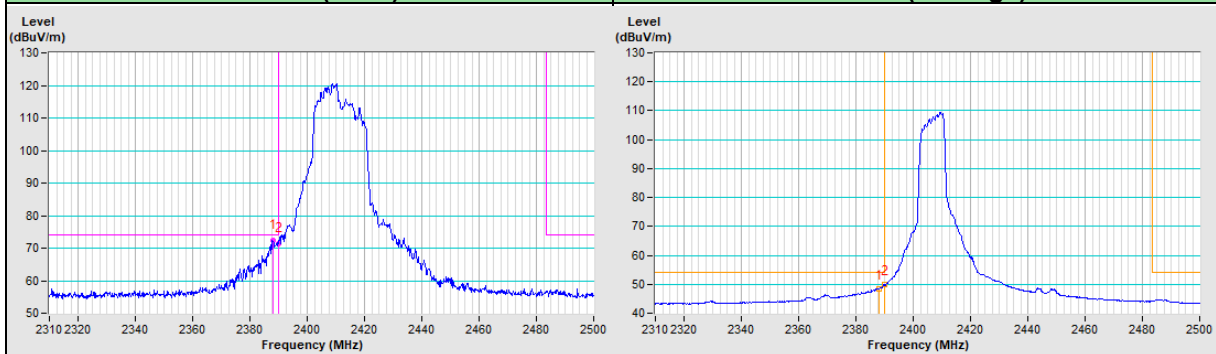

20MHz Preamble 802.11ax (RU106) Channel 11

Horizontal (Peak)	Horizontal (Average)
-------------------	----------------------

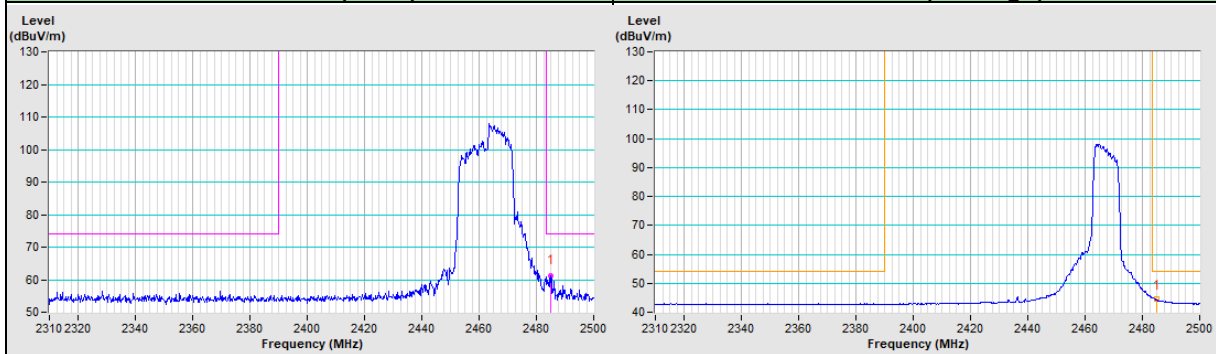

Vertical (Peak)	Vertical (Average)
-----------------	--------------------

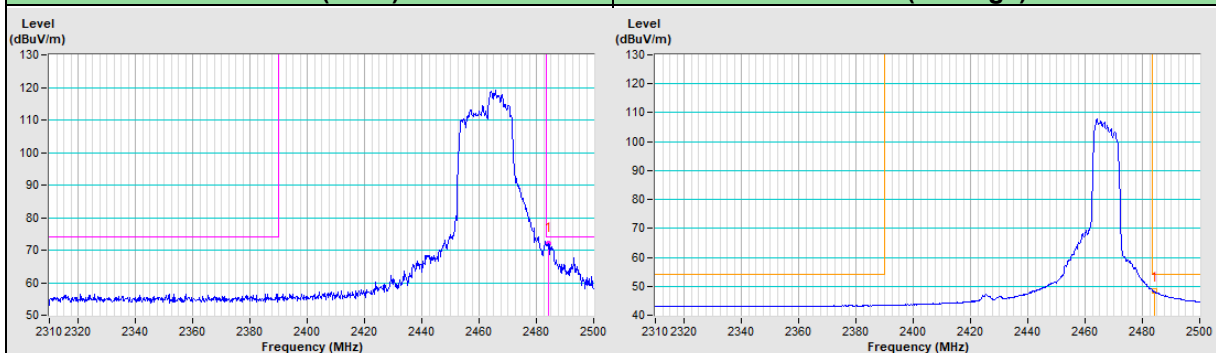

20MHz Preamble 802.11ax (RU106) Channel 12

Horizontal (Peak)

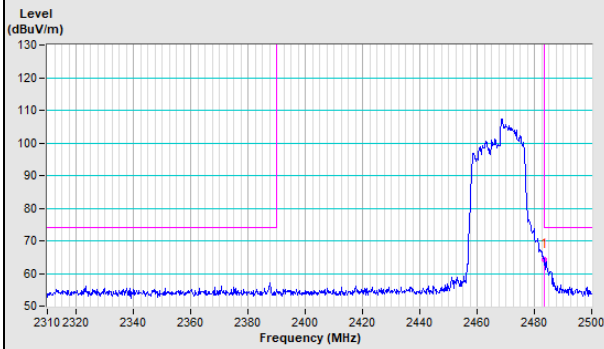

Horizontal (Average)

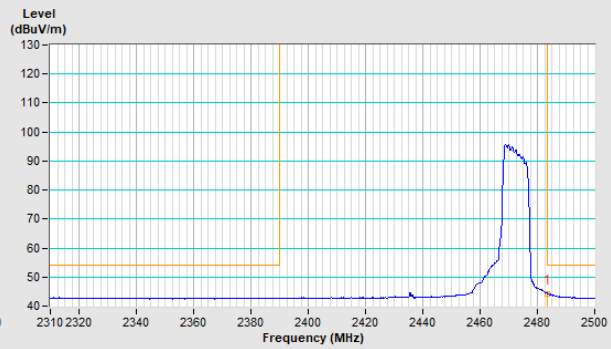

Vertical (Peak)

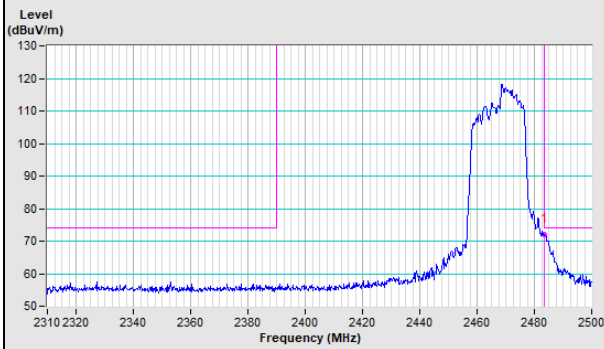

Vertical (Average)

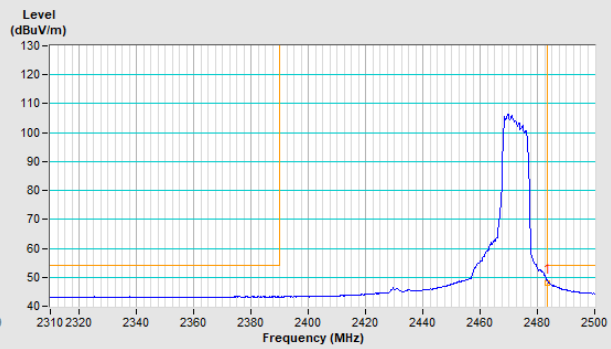

20MHz Preamble 802.11ax (RU106) Channel 13

Horizontal (Peak)

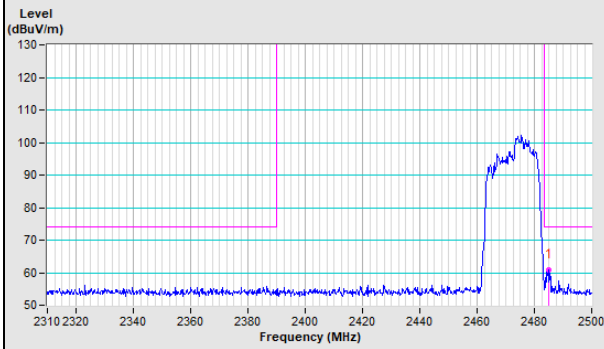

Horizontal (Average)

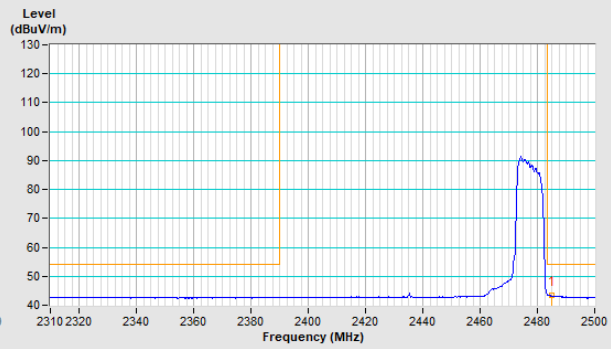

Vertical (Peak)

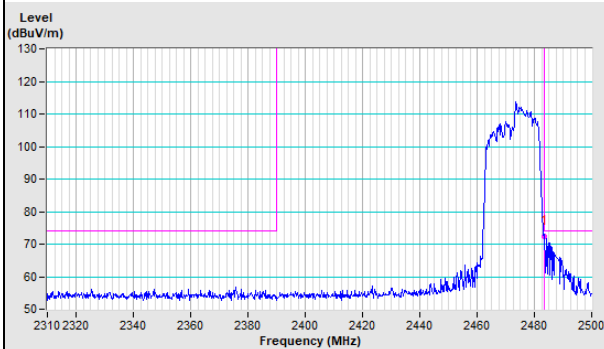

Vertical (Average)

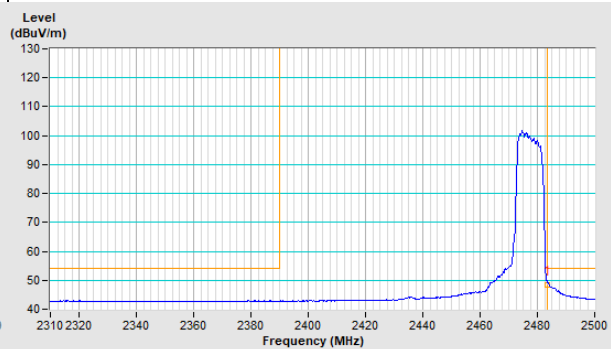

PIFA Antenna

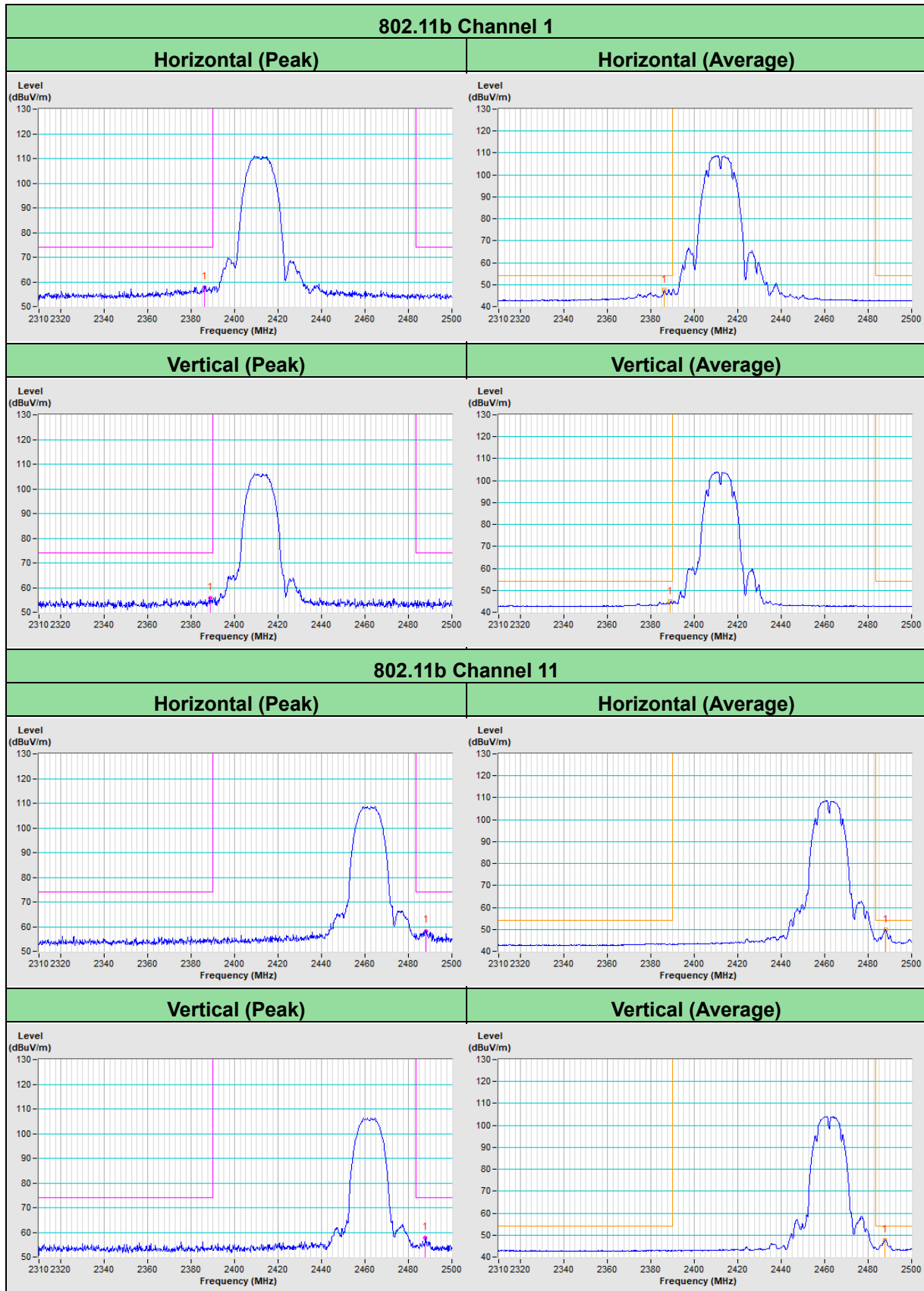

802.11b Channel 12

Horizontal (Peak)	Horizontal (Average)
-------------------	----------------------

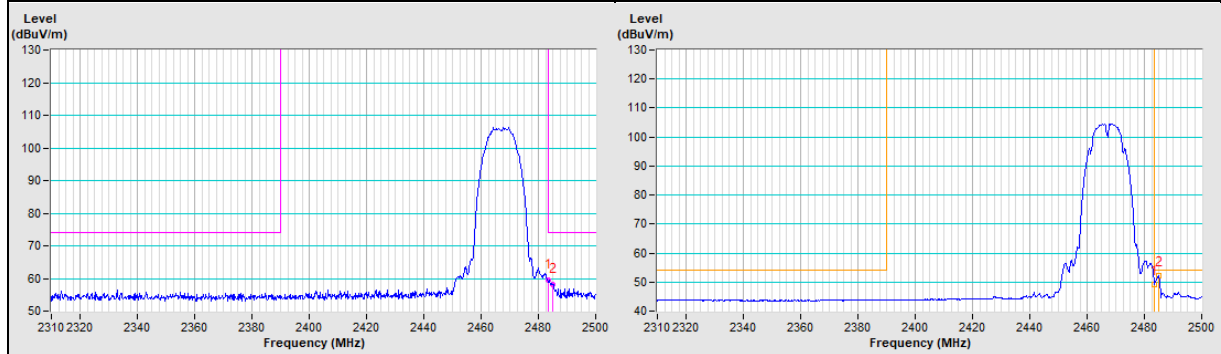

Vertical (Peak)	Vertical (Average)
-----------------	--------------------

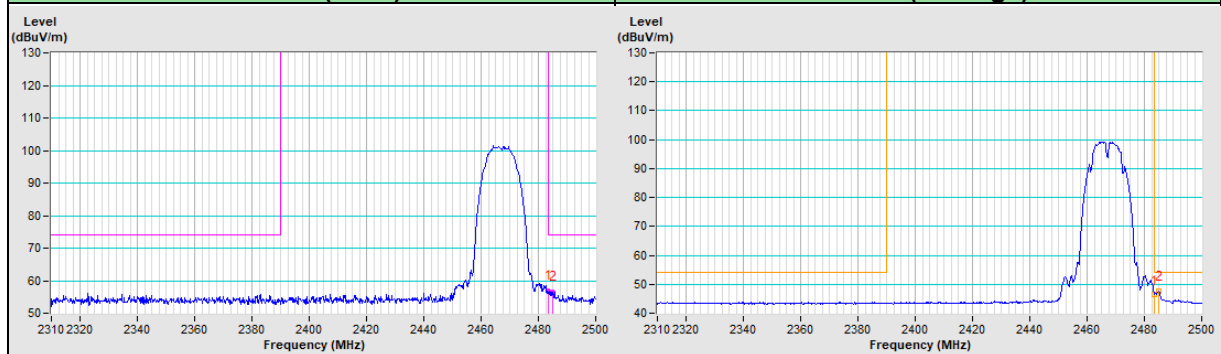

802.11b Channel 13

Horizontal (Peak)	Horizontal (Average)
-------------------	----------------------

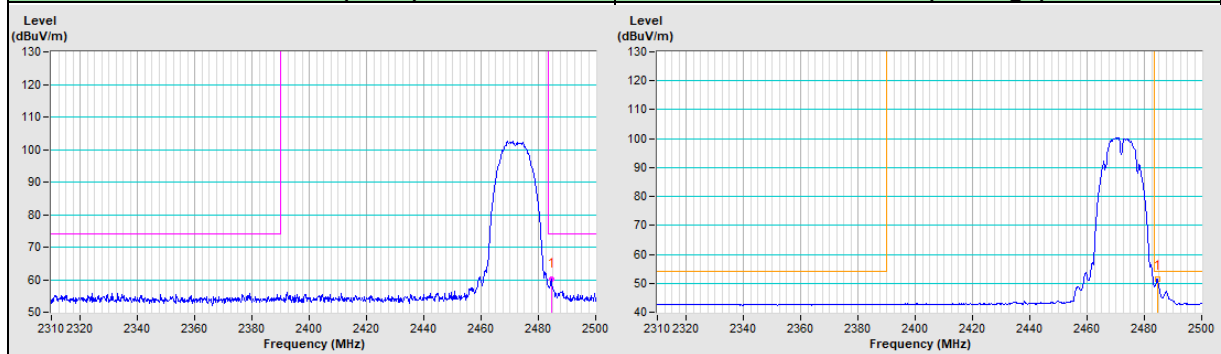

Vertical (Peak)	Vertical (Average)
-----------------	--------------------

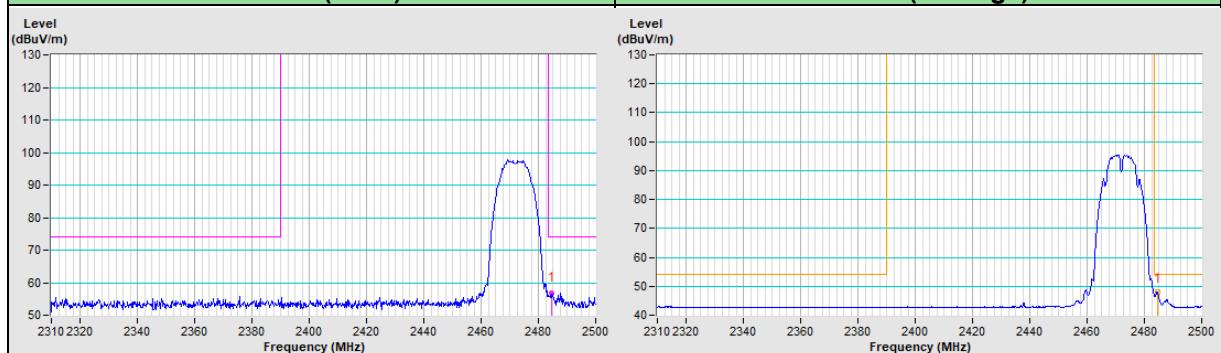

802.11g Channel 1

Horizontal (Peak)	Horizontal (Average)
-------------------	----------------------

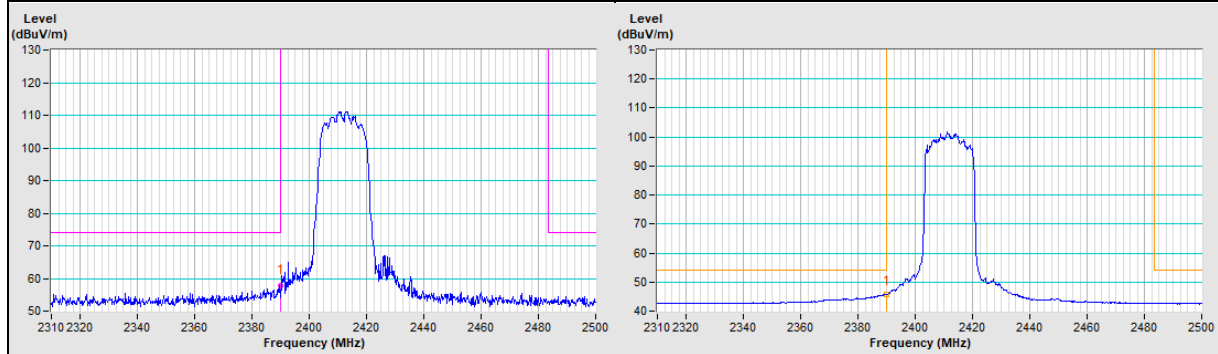

Vertical (Peak)	Vertical (Average)
-----------------	--------------------

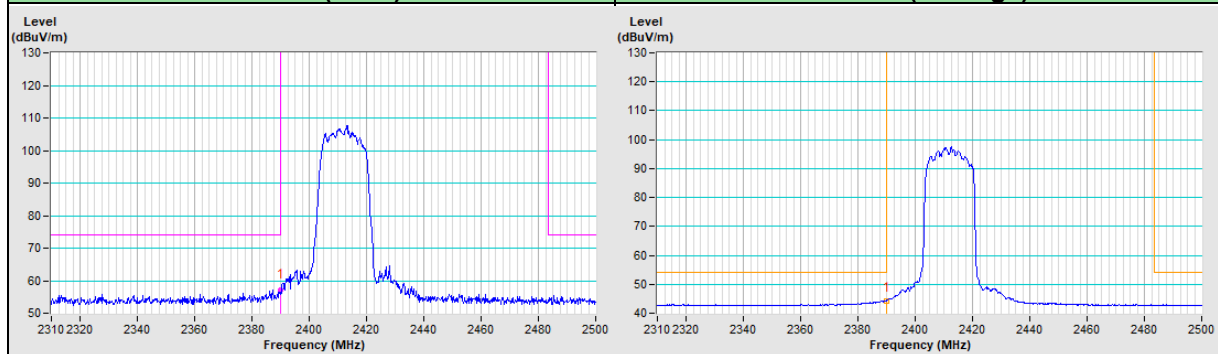

802.11g Channel 11

Horizontal (Peak)	Horizontal (Average)
-------------------	----------------------

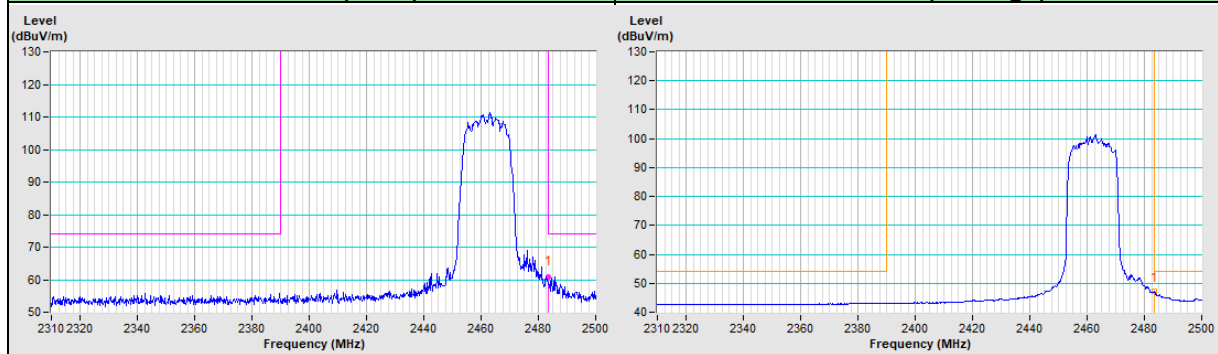

Vertical (Peak)	Vertical (Average)
-----------------	--------------------

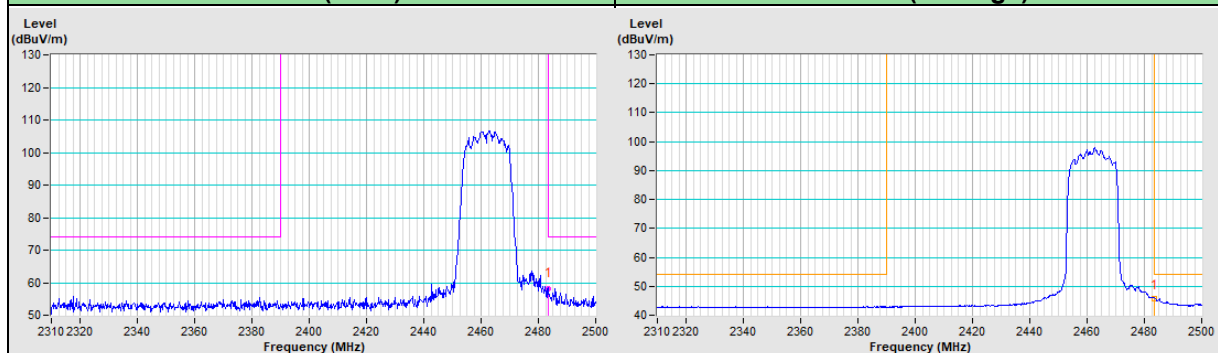

802.11g Channel 12

Horizontal (Peak)	Horizontal (Average)
-------------------	----------------------

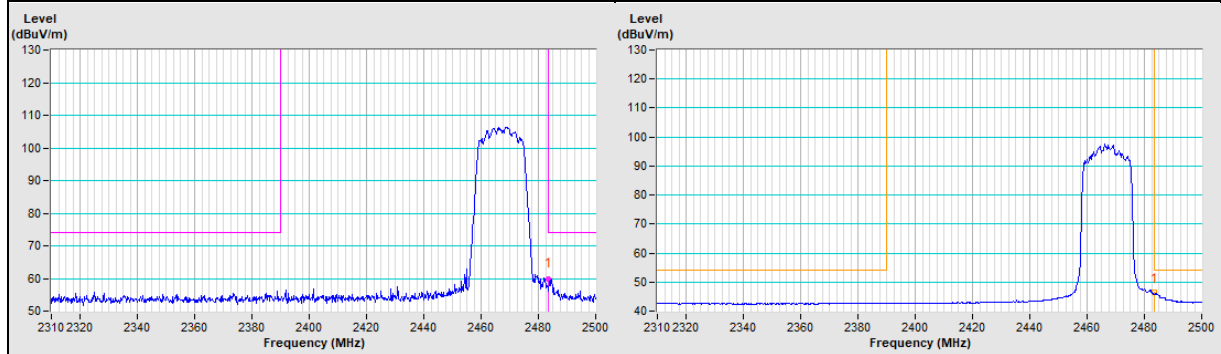

Vertical (Peak)	Vertical (Average)
-----------------	--------------------

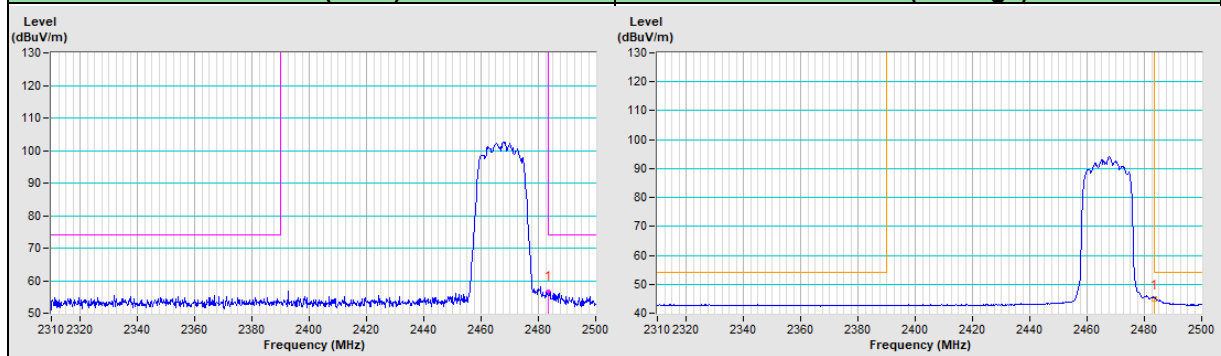

802.11g Channel 13

Horizontal (Peak)	Horizontal (Average)
-------------------	----------------------

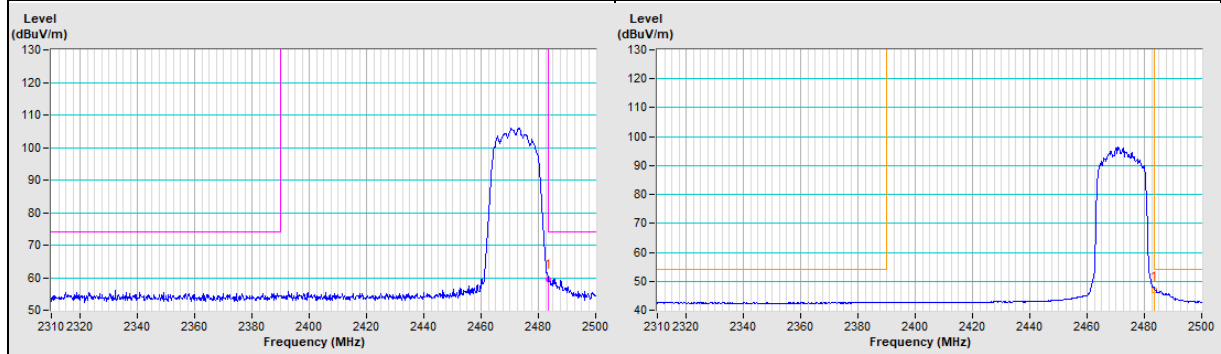

Vertical (Peak)	Vertical (Average)
-----------------	--------------------

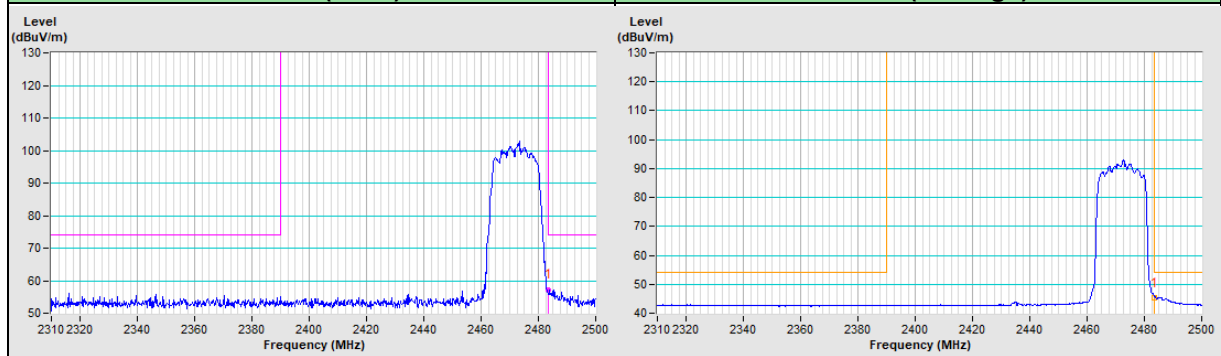

802.11ax (HE20) Channel 1

Horizontal (Peak)

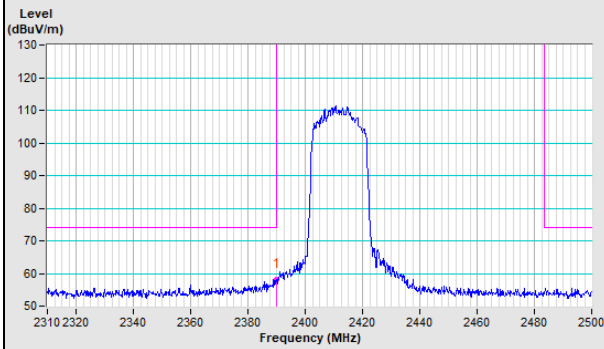

Horizontal (Average)

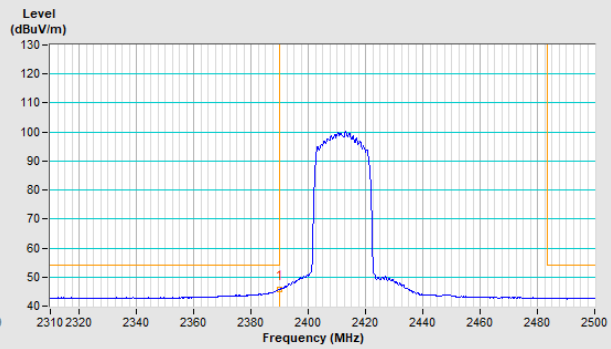

Vertical (Peak)

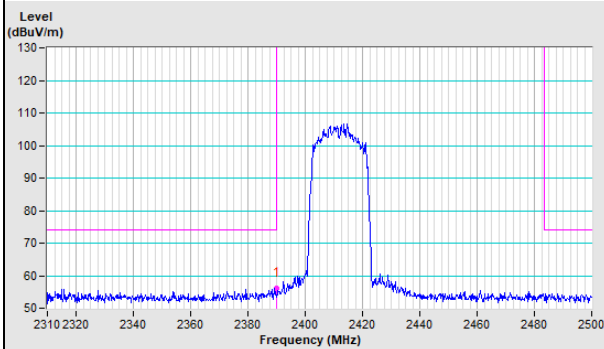

Vertical (Average)

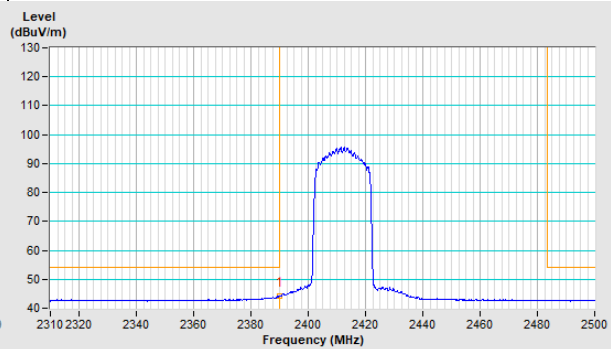

802.11ax (HE20) Channel 11

Horizontal (Peak)

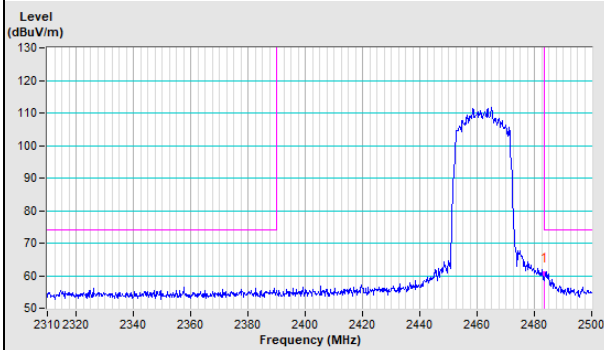

Horizontal (Average)

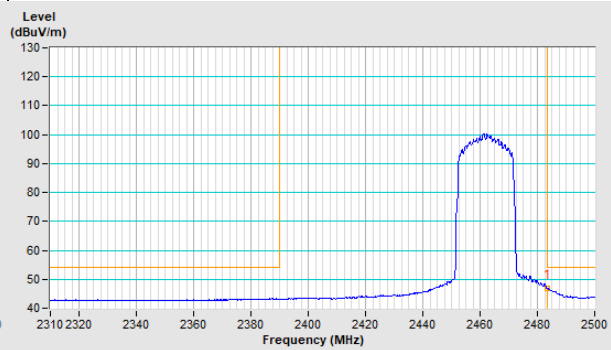

Vertical (Peak)

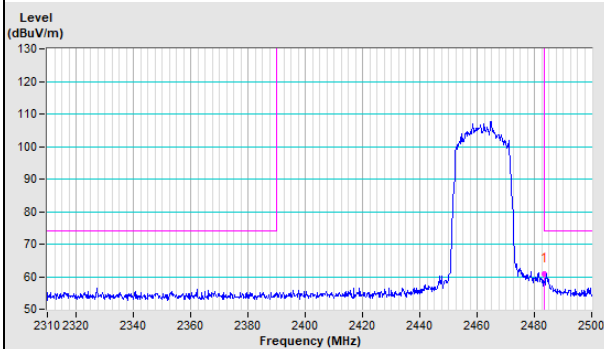

Vertical (Average)

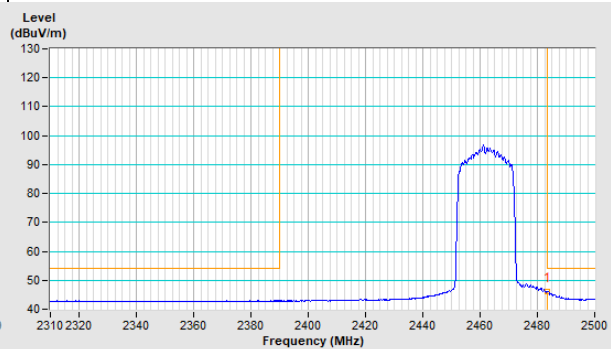

802.11ax (HE20) Channel 12

Horizontal (Peak)

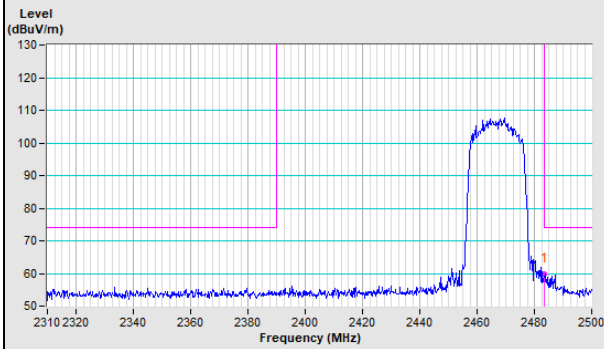

Horizontal (Average)

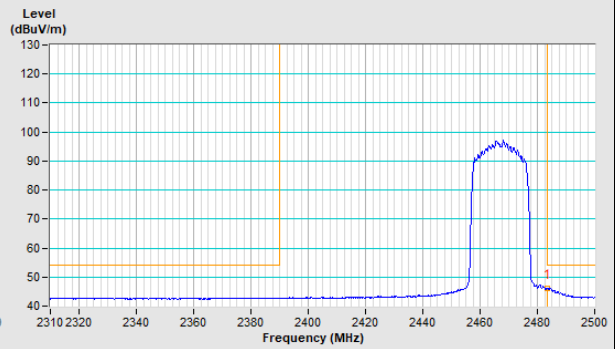

Vertical (Peak)

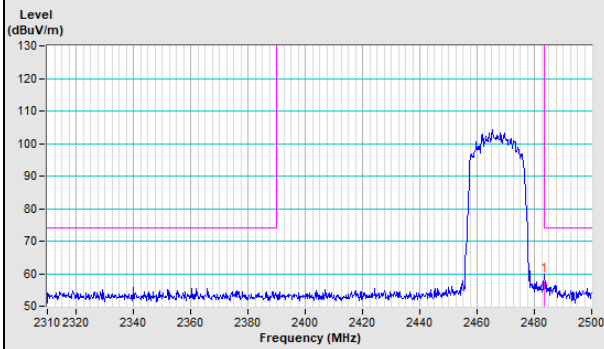

Vertical (Average)

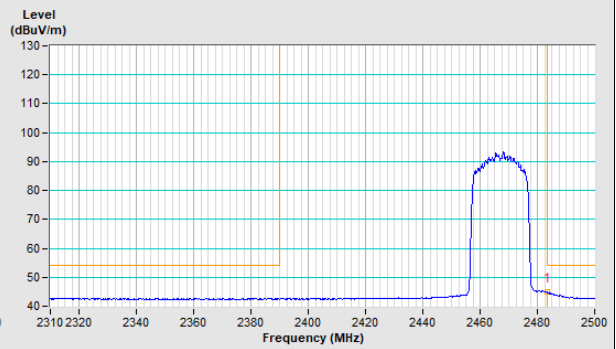

802.11ax (HE20) Channel 13

Horizontal (Peak)

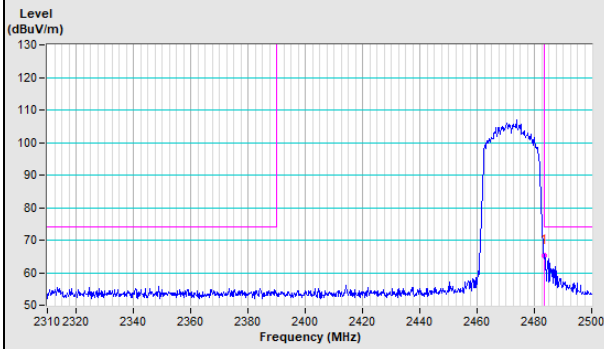

Horizontal (Average)

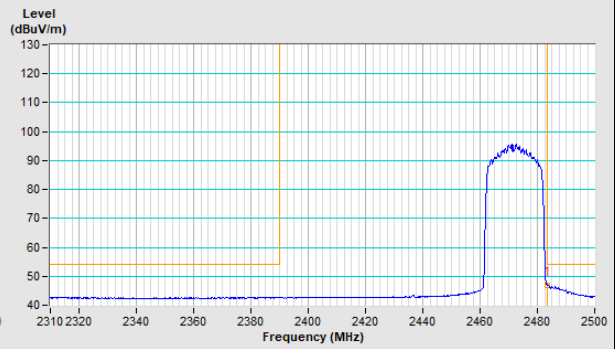

Vertical (Peak)

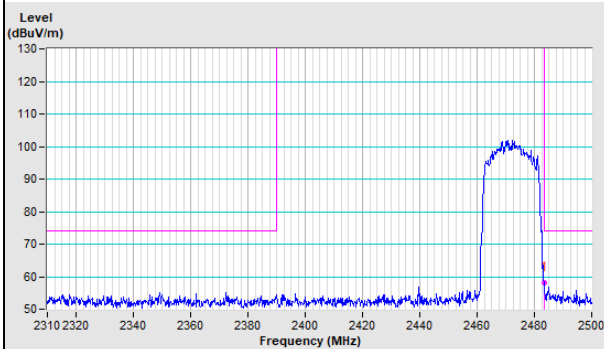

Vertical (Average)

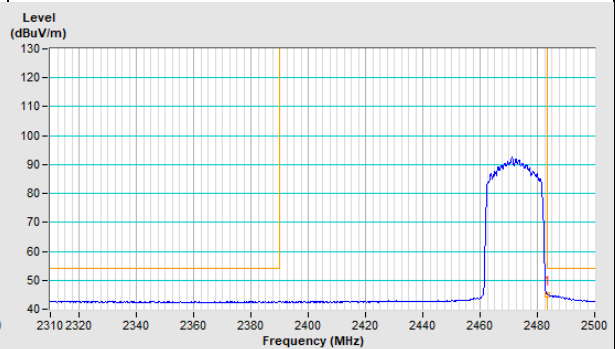

802.11ax (HE40) Channel 3

Horizontal (Peak)	Horizontal (Average)
-------------------	----------------------

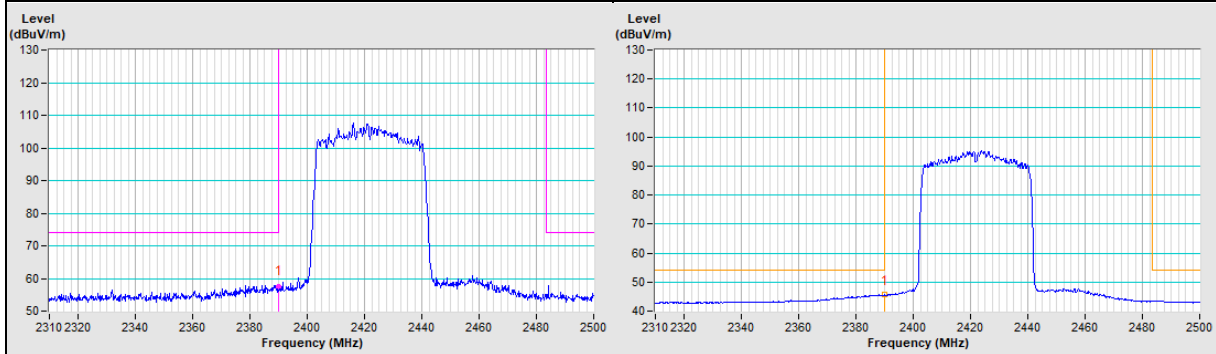

Vertical (Peak)	Vertical (Average)
-----------------	--------------------

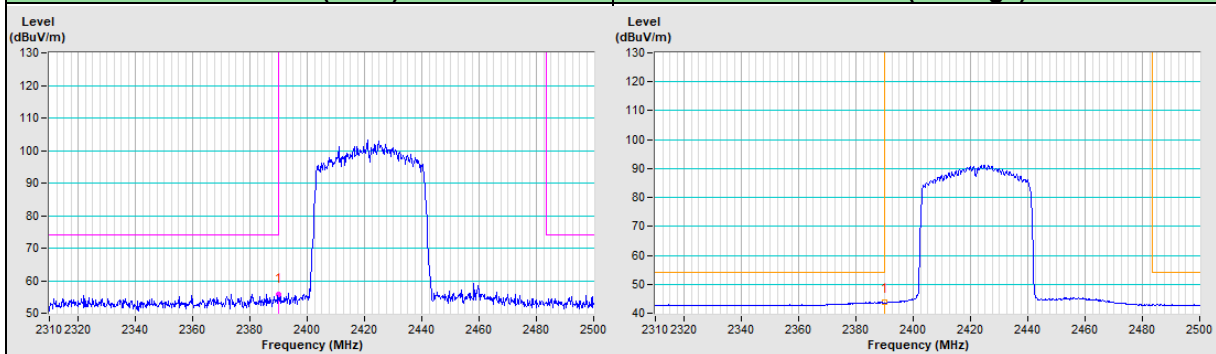

802.11ax (HE40) Channel 9

Horizontal (Peak)	Horizontal (Average)
-------------------	----------------------

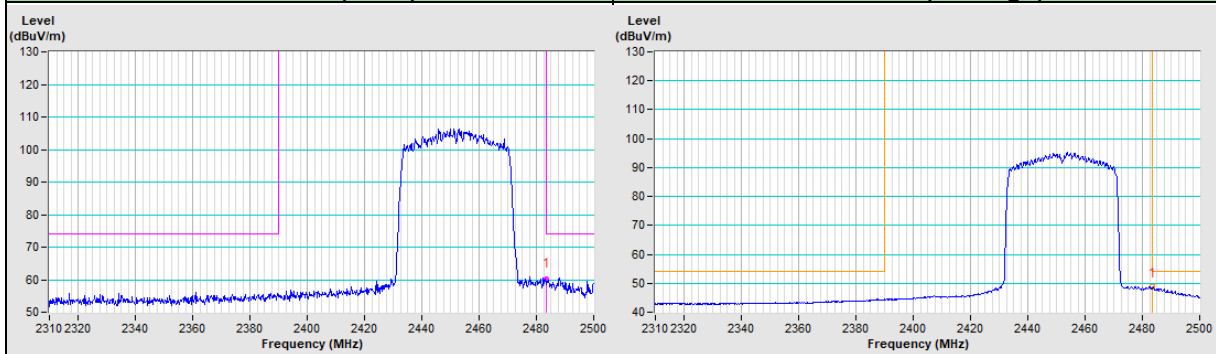

Vertical (Peak)	Vertical (Average)
-----------------	--------------------

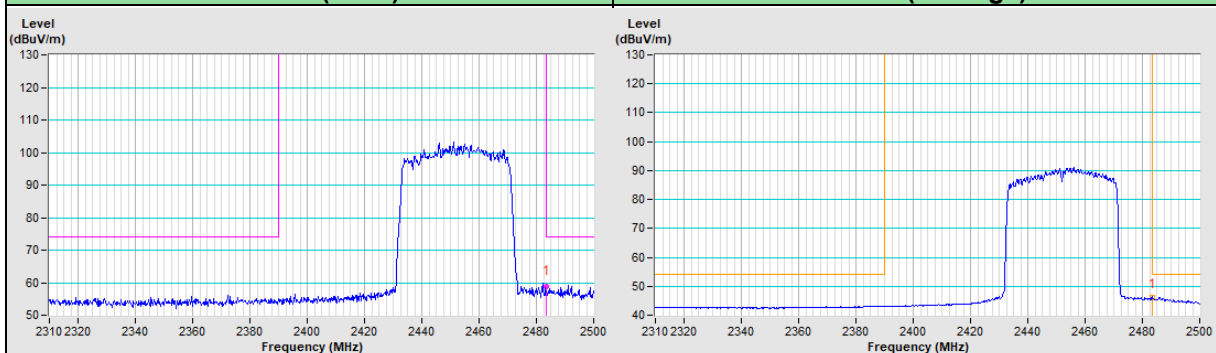

802.11ax (HE40) Channel 10

Horizontal (Peak)	Horizontal (Average)
-------------------	----------------------

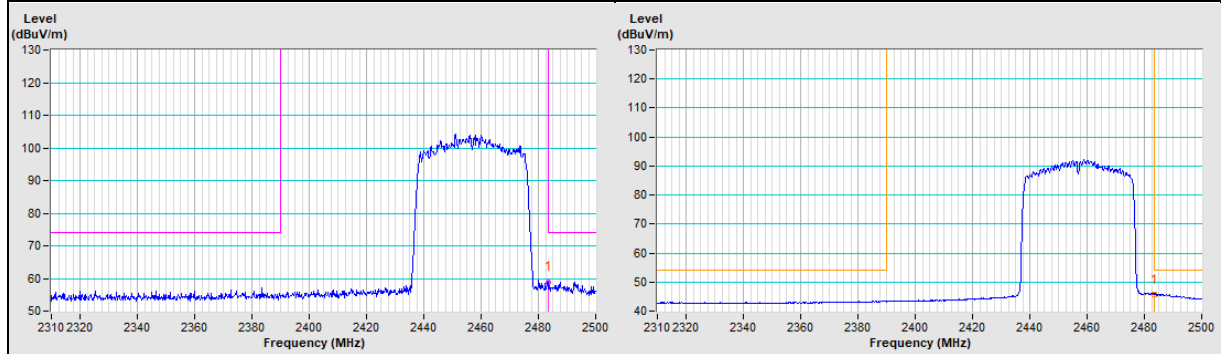

Vertical (Peak)	Vertical (Average)
-----------------	--------------------

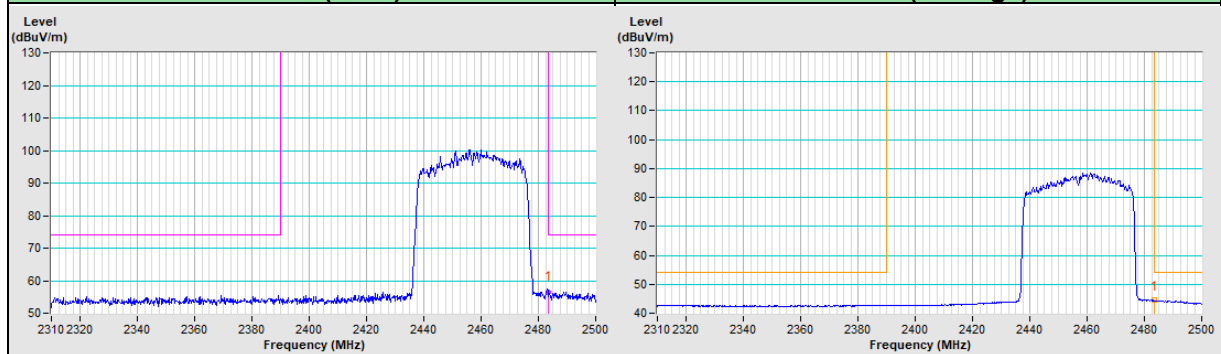

802.11ax (HE40) Channel 11

Horizontal (Peak)	Horizontal (Average)
-------------------	----------------------

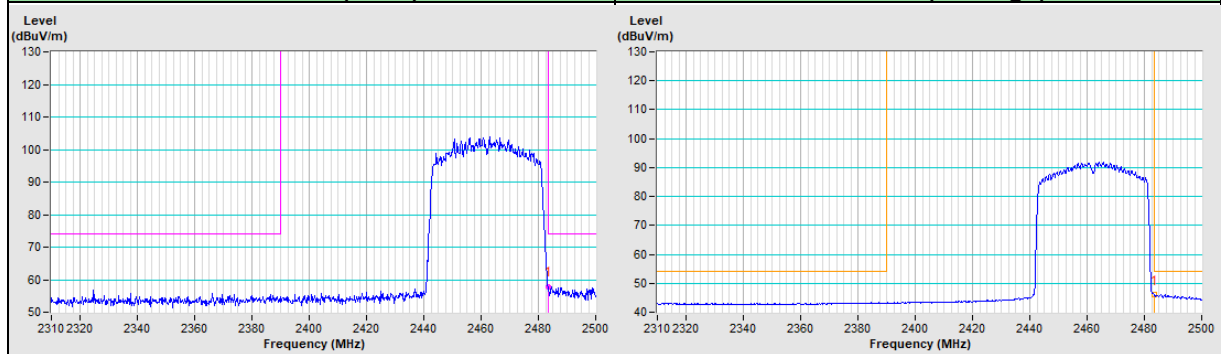

Vertical (Peak)	Vertical (Average)
-----------------	--------------------

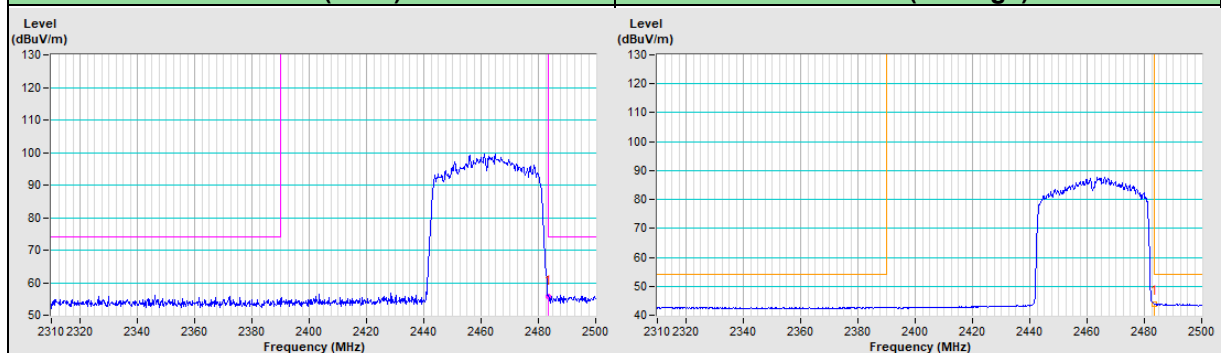

20MHz Preamble 802.11ax (RU26) Channel 1

Horizontal (Peak)	Horizontal (Average)
--------------------------	-----------------------------

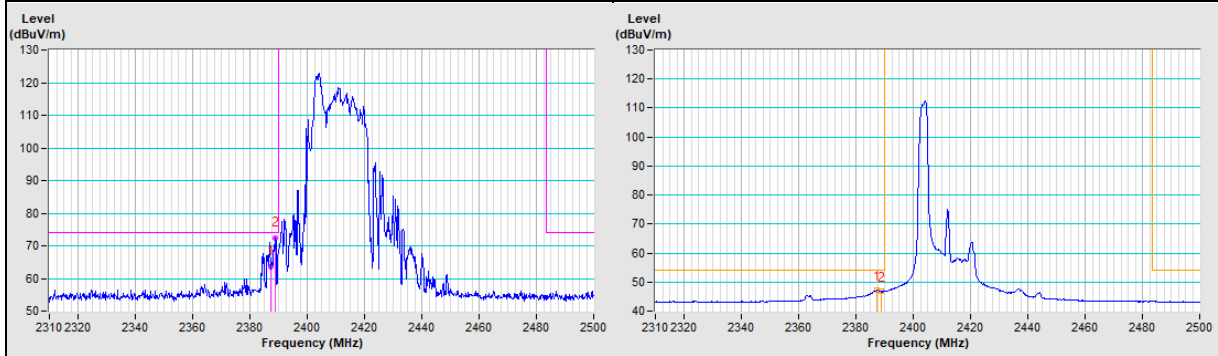

Vertical (Peak)	Vertical (Average)
------------------------	---------------------------

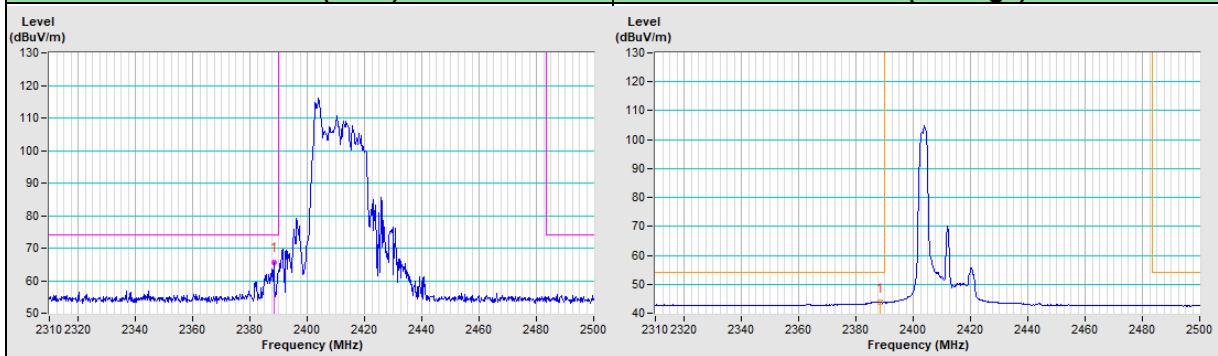

20MHz Preamble 802.11ax (RU26) Channel 11

Horizontal (Peak)	Horizontal (Average)
--------------------------	-----------------------------

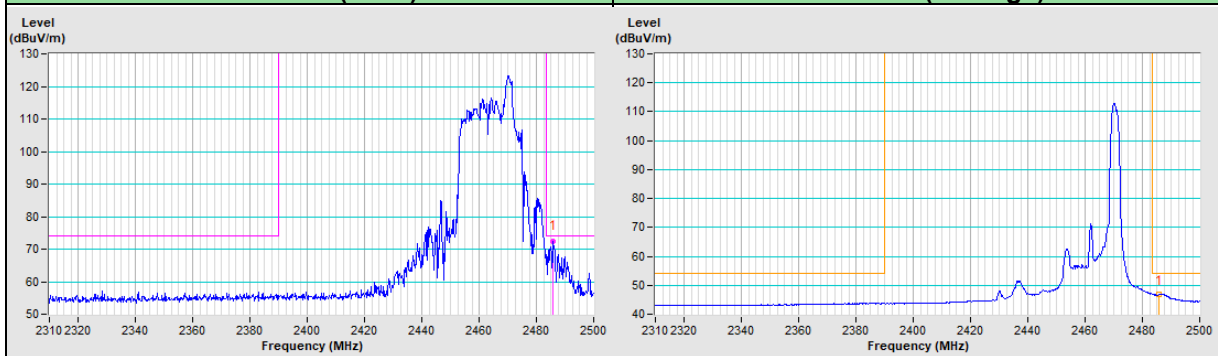

Vertical (Peak)	Vertical (Average)
------------------------	---------------------------

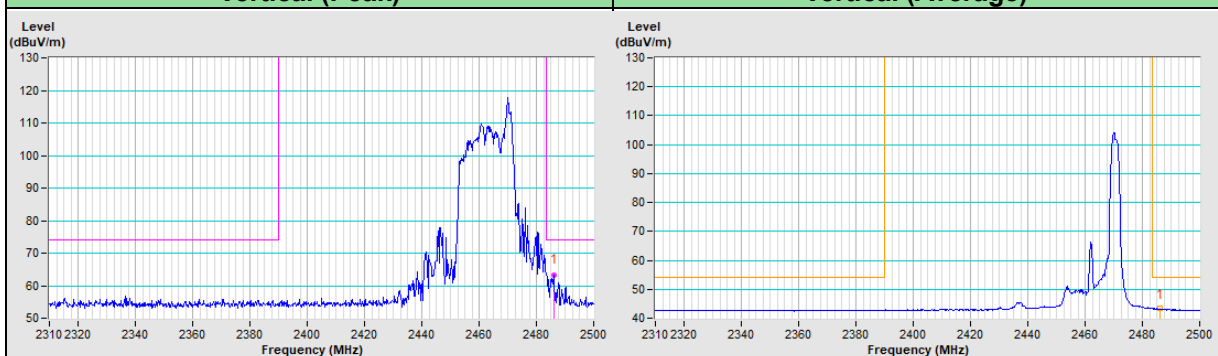

20MHz Preamble 802.11ax (RU26) Channel 12

Horizontal (Peak)

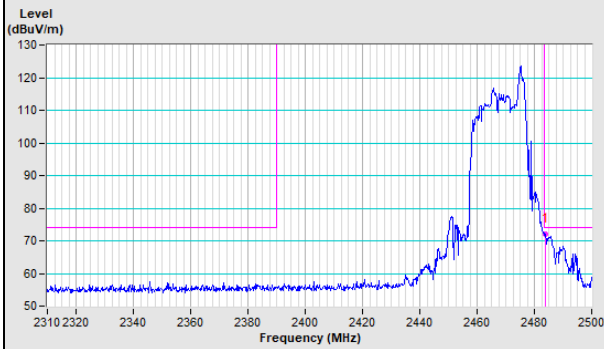

Horizontal (Average)

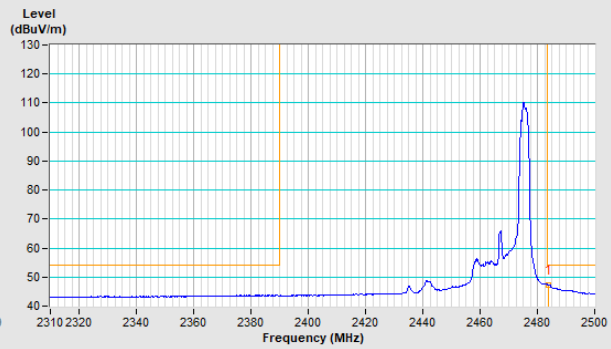

Vertical (Peak)

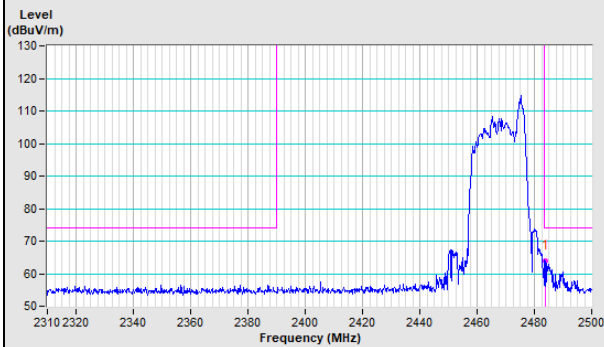

Vertical (Average)

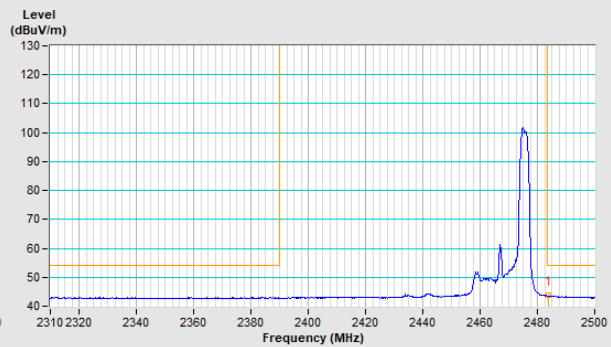

20MHz Preamble 802.11ax (RU26) Channel 13

Horizontal (Peak)

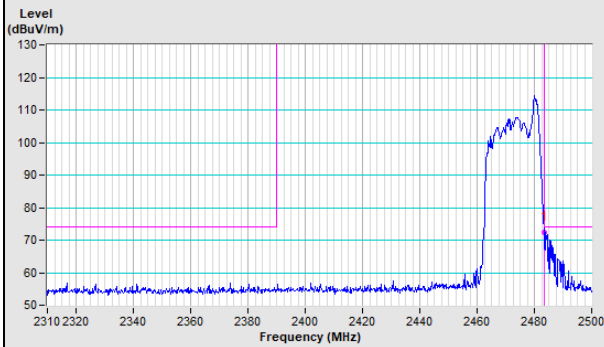

Horizontal (Average)

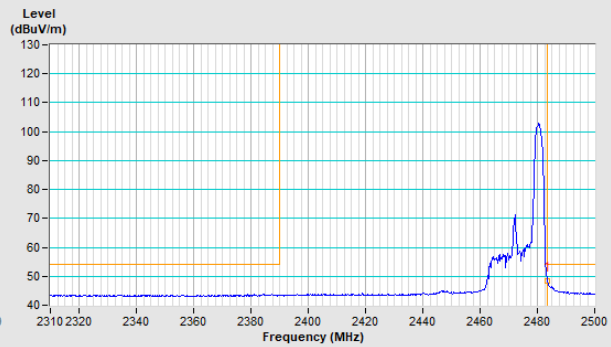

Vertical (Peak)

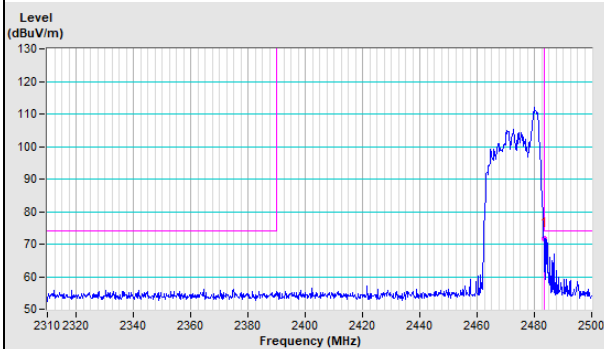

Vertical (Average)

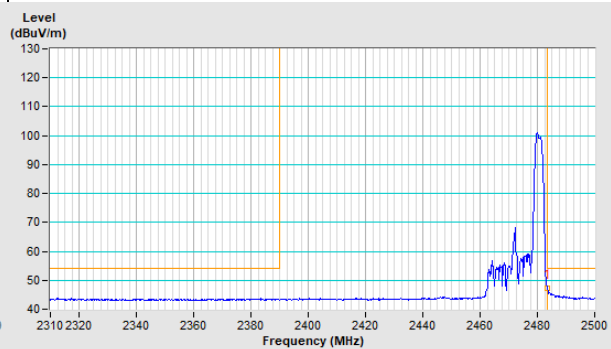

20MHz Preamble 802.11ax (RU52) Channel 1

Horizontal (Peak)	Horizontal (Average)
--------------------------	-----------------------------

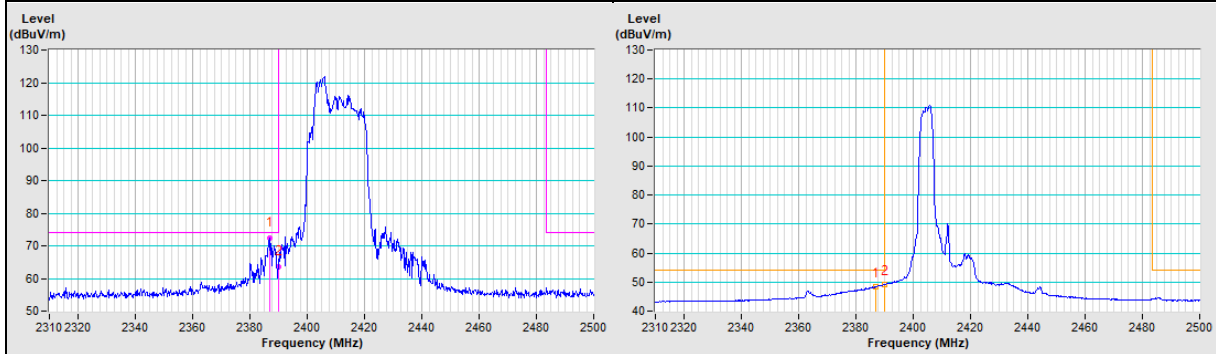

Vertical (Peak)	Vertical (Average)
------------------------	---------------------------

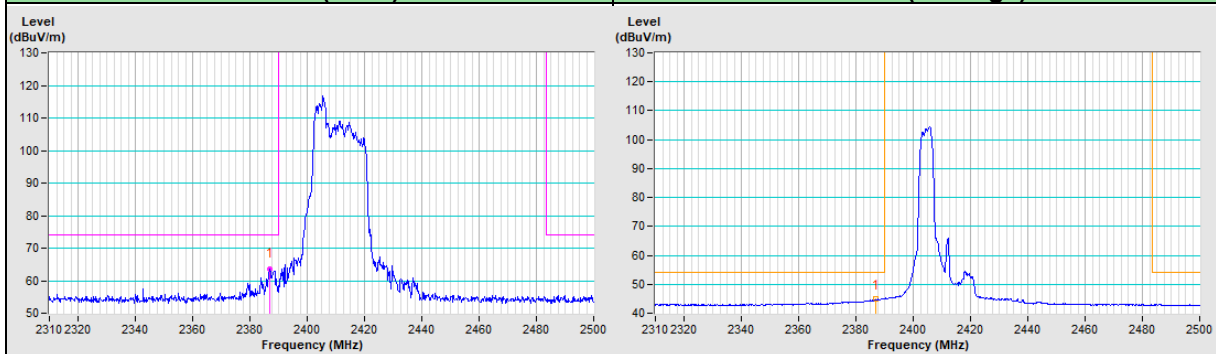

20MHz Preamble 802.11ax (RU52) Channel 11

Horizontal (Peak)	Horizontal (Average)
--------------------------	-----------------------------

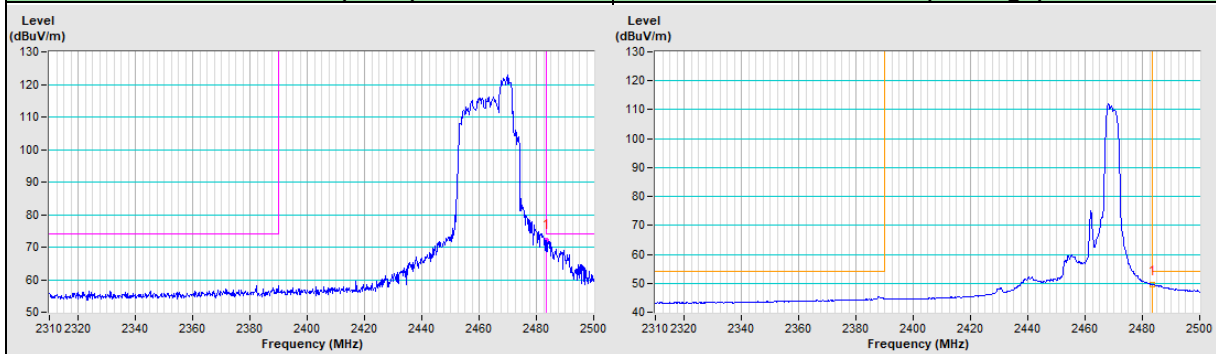

Vertical (Peak)	Vertical (Average)
------------------------	---------------------------

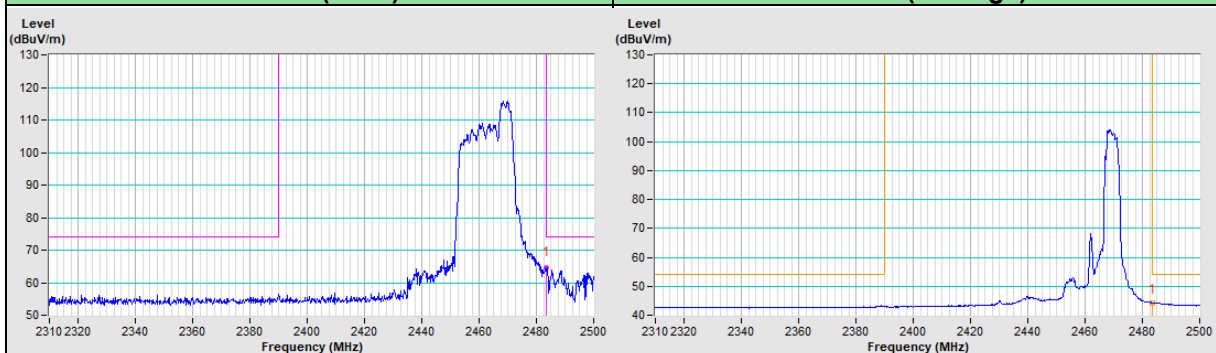

20MHz Preamble 802.11ax (RU52) Channel 12

Horizontal (Peak)

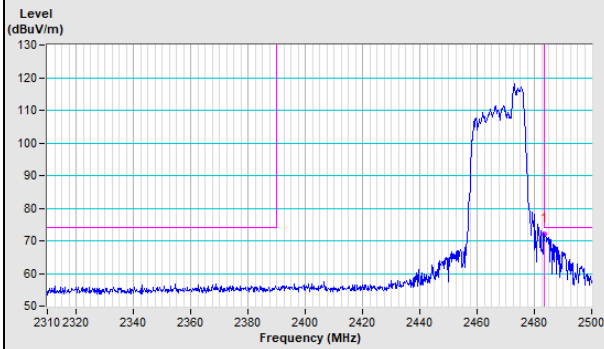

Horizontal (Average)

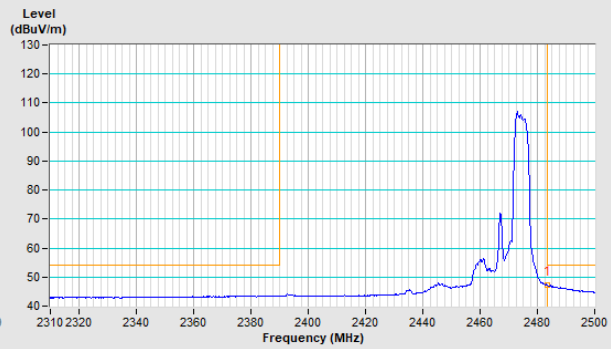

Vertical (Peak)

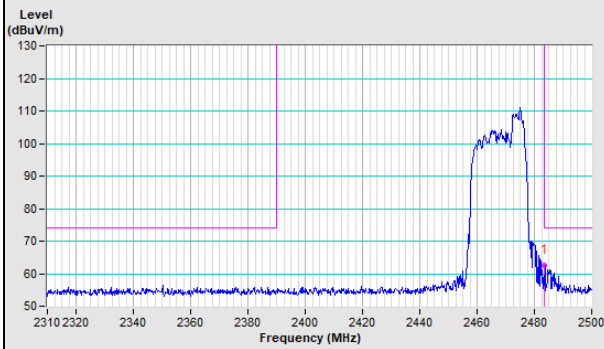

Vertical (Average)

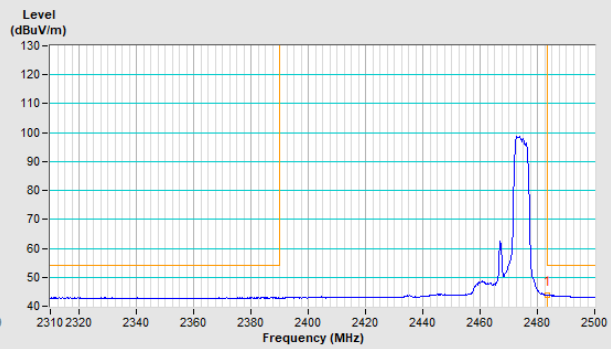

20MHz Preamble 802.11ax (RU52) Channel 13

Horizontal (Peak)

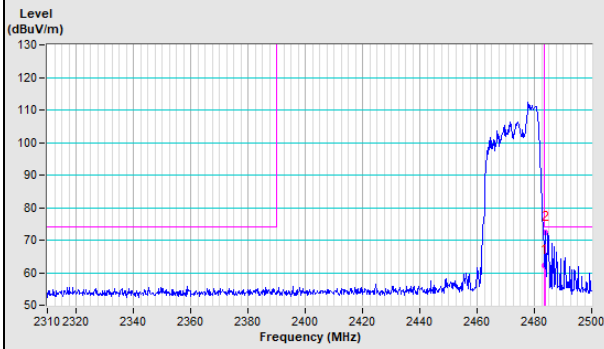

Horizontal (Average)

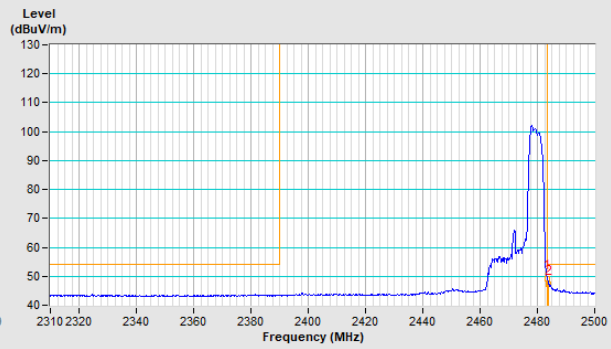

Vertical (Peak)

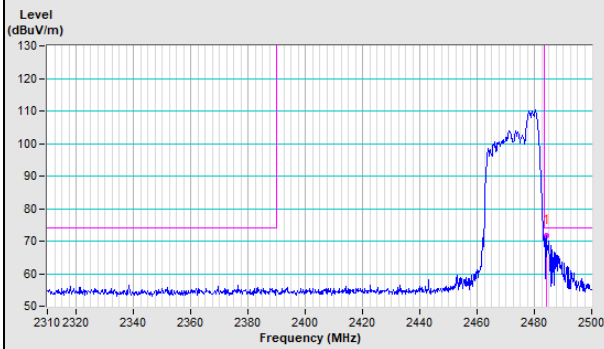

Vertical (Average)

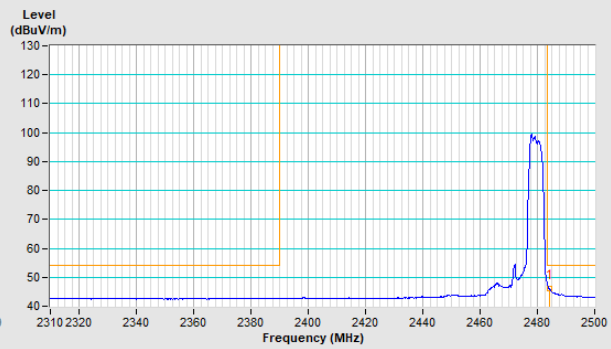

20MHz Preamble 802.11ax (RU106) Channel 1

Horizontal (Peak)	Horizontal (Average)
--------------------------	-----------------------------

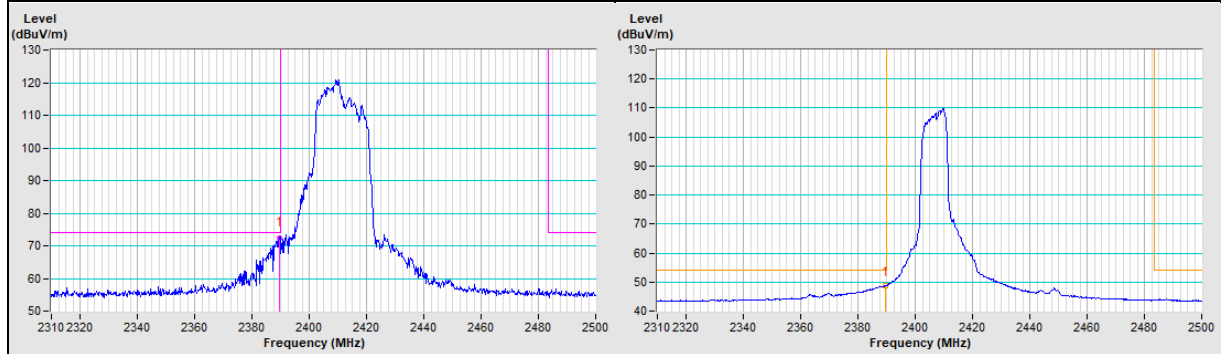

Vertical (Peak)	Vertical (Average)
------------------------	---------------------------

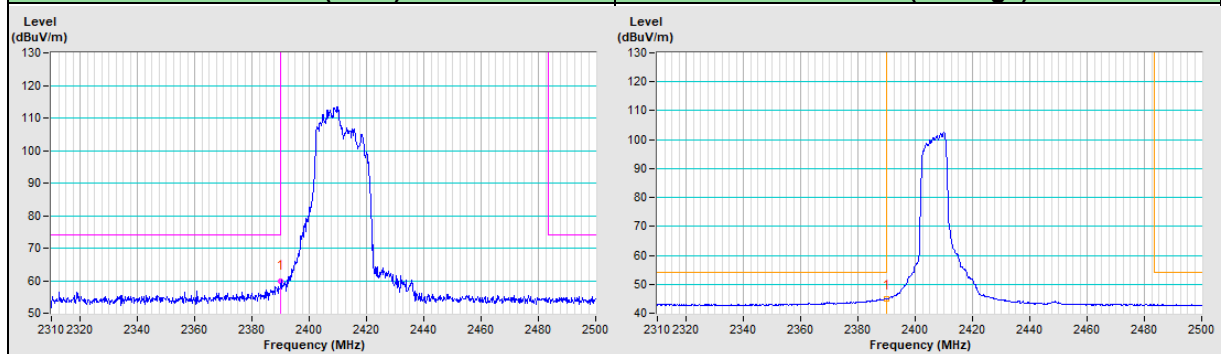

20MHz Preamble 802.11ax (RU106) Channel 11

Horizontal (Peak)	Horizontal (Average)
--------------------------	-----------------------------

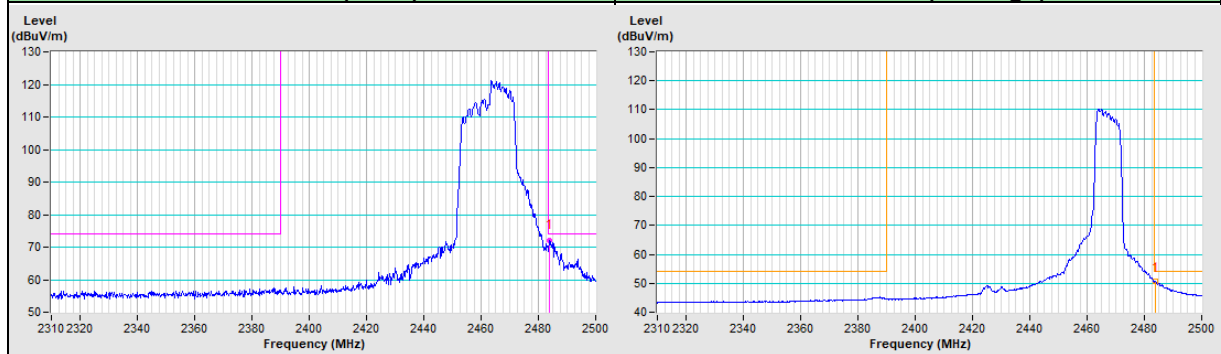

Vertical (Peak)	Vertical (Average)
------------------------	---------------------------

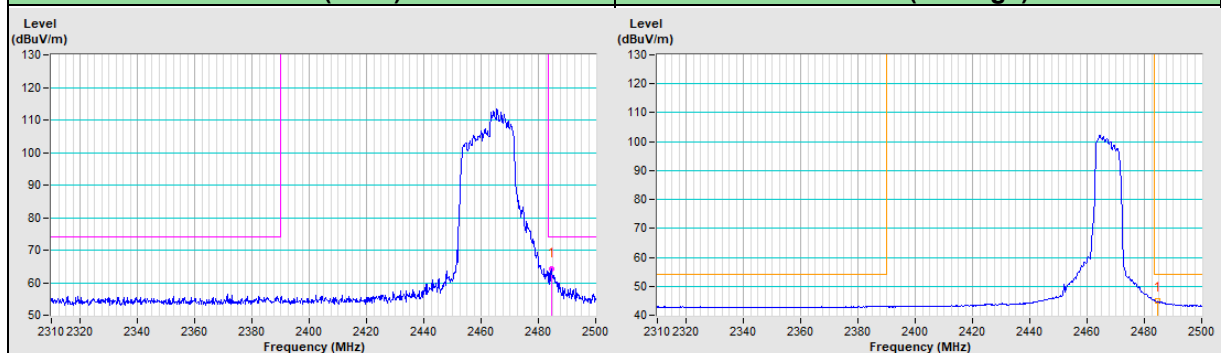

20MHz Preamble 802.11ax (RU106) Channel 12

Horizontal (Peak)

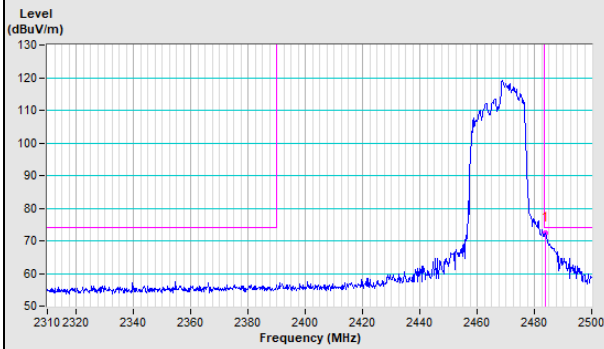

Horizontal (Average)

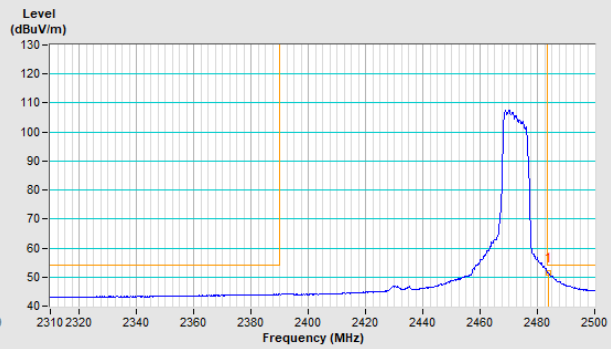

Vertical (Peak)

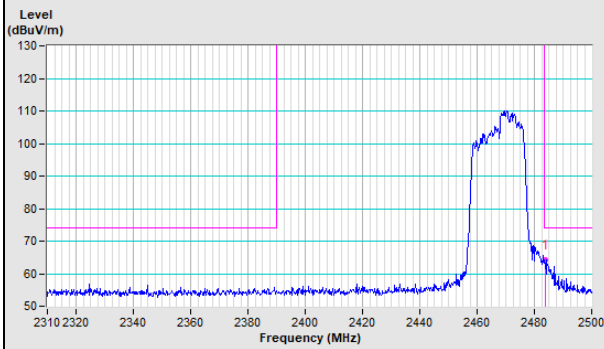

Vertical (Average)

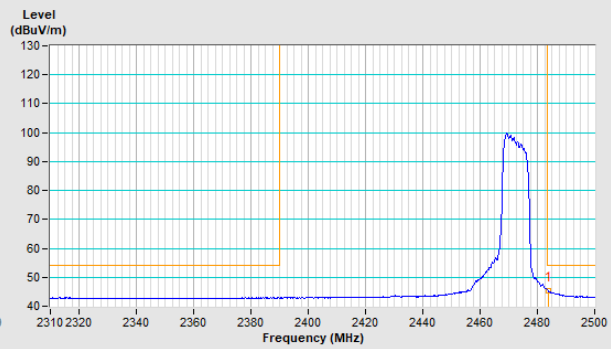

20MHz Preamble 802.11ax (RU106) Channel 13

Horizontal (Peak)

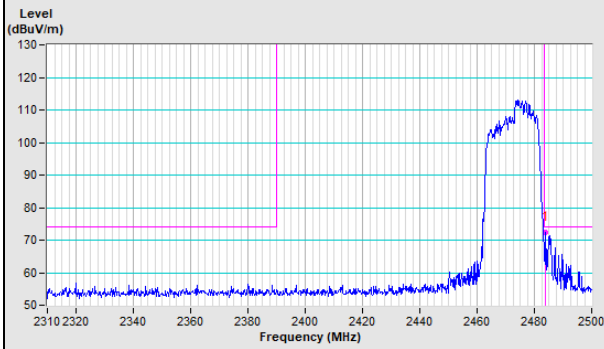

Horizontal (Average)

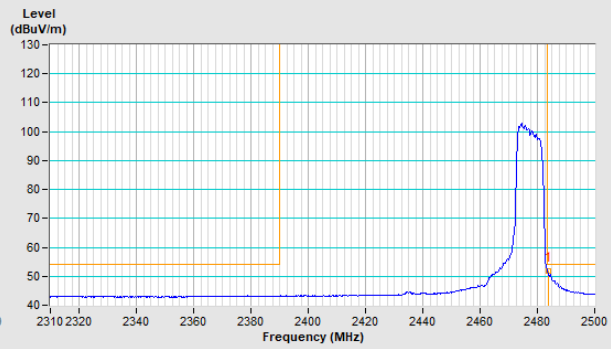

Vertical (Peak)

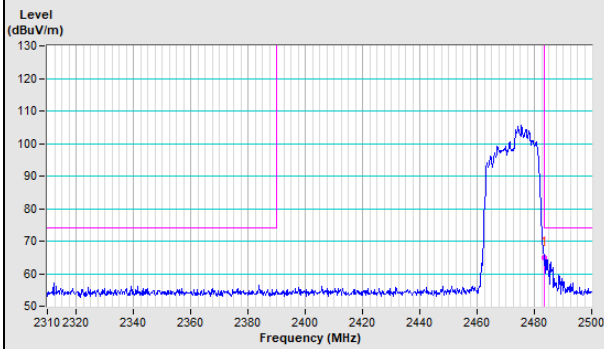

Vertical (Average)

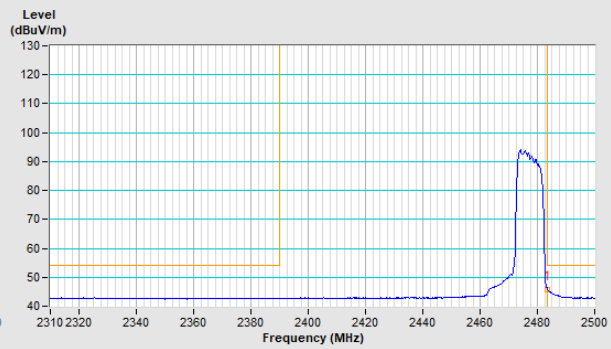

Annex A.2 - Test Results (Mode 2)

Dipole Antenna

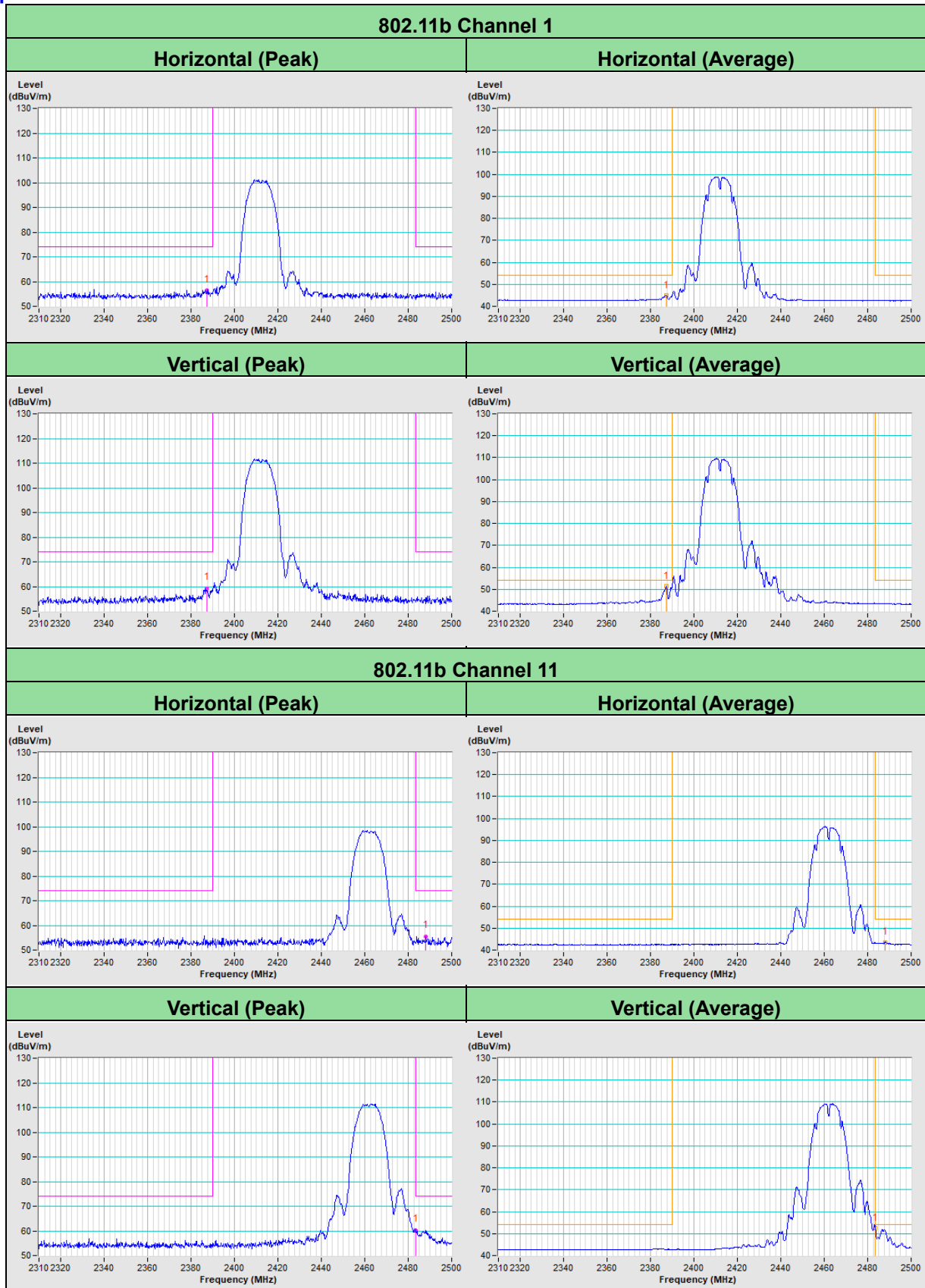

802.11b Channel 12

Horizontal (Peak)	Horizontal (Average)
-------------------	----------------------

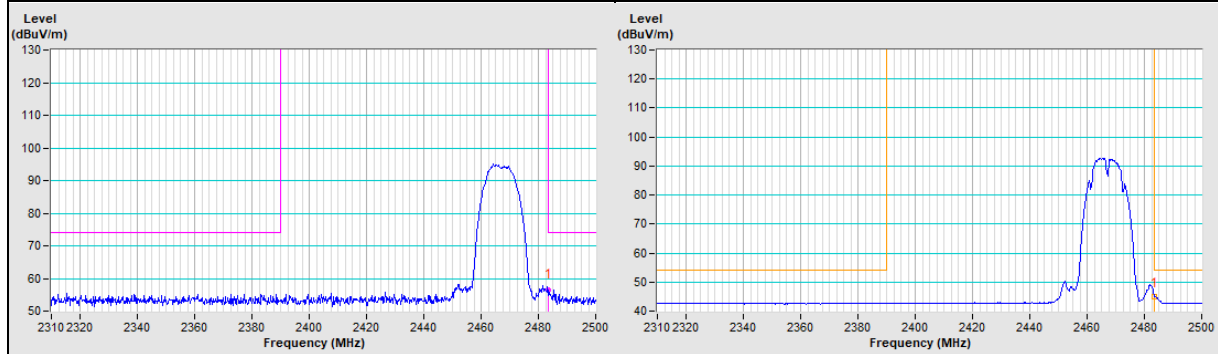

Vertical (Peak)	Vertical (Average)
-----------------	--------------------

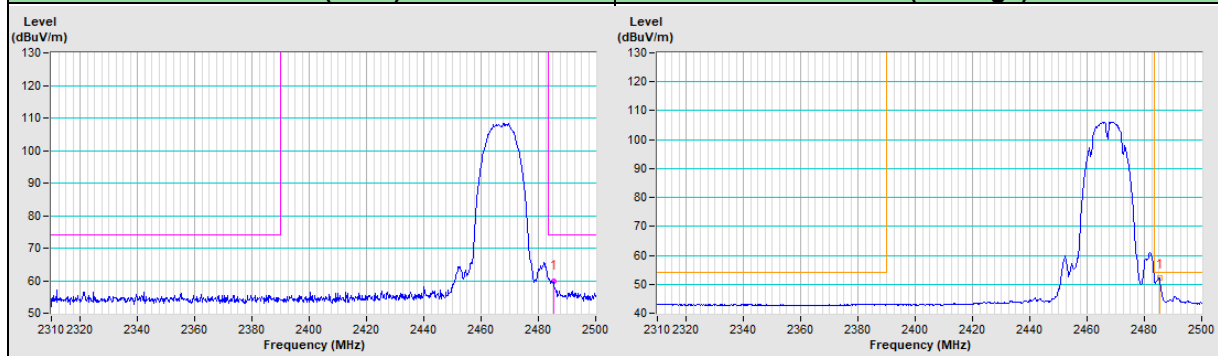

802.11b Channel 13

Horizontal (Peak)	Horizontal (Average)
-------------------	----------------------

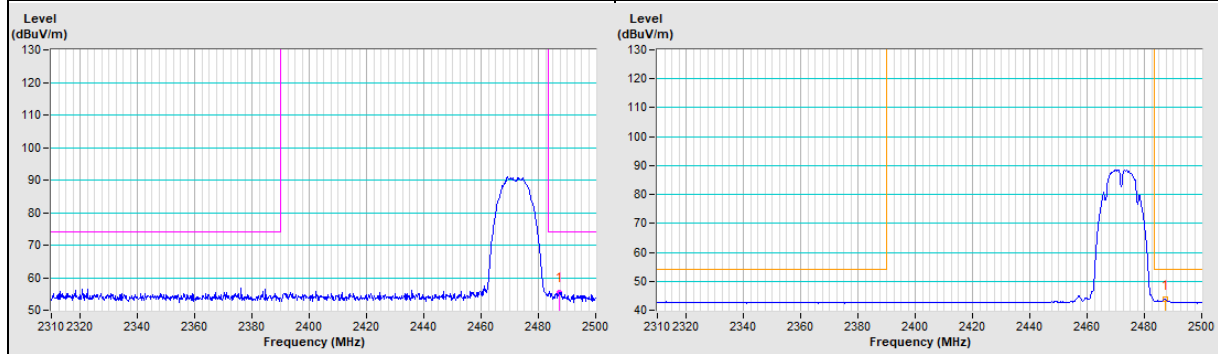

Vertical (Peak)	Vertical (Average)
-----------------	--------------------

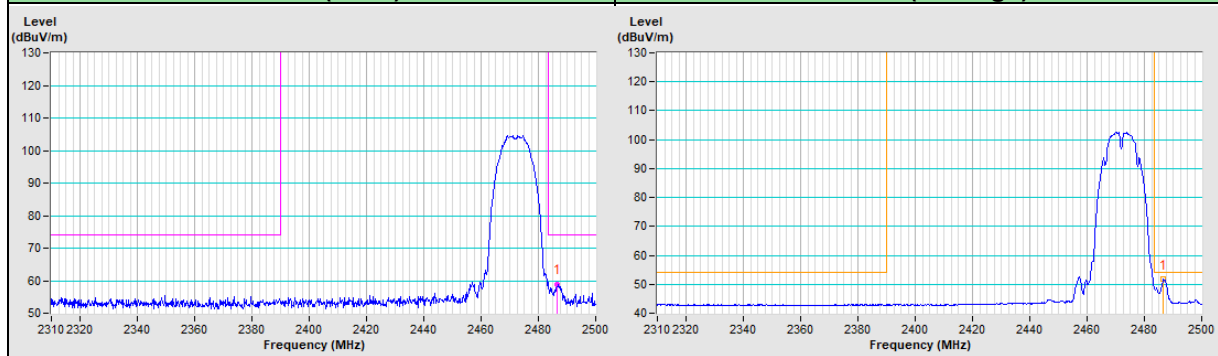

802.11g Channel 1

Horizontal (Peak)	Horizontal (Average)
--------------------------	-----------------------------

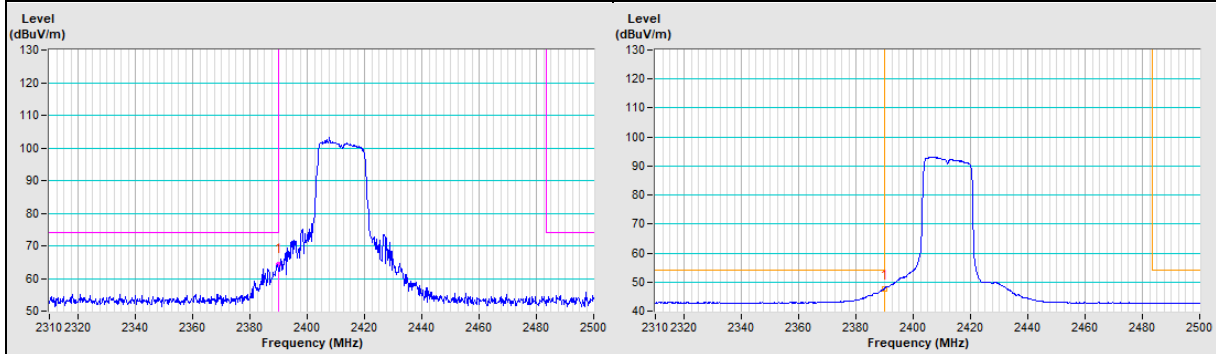

Vertical (Peak)	Vertical (Average)
------------------------	---------------------------

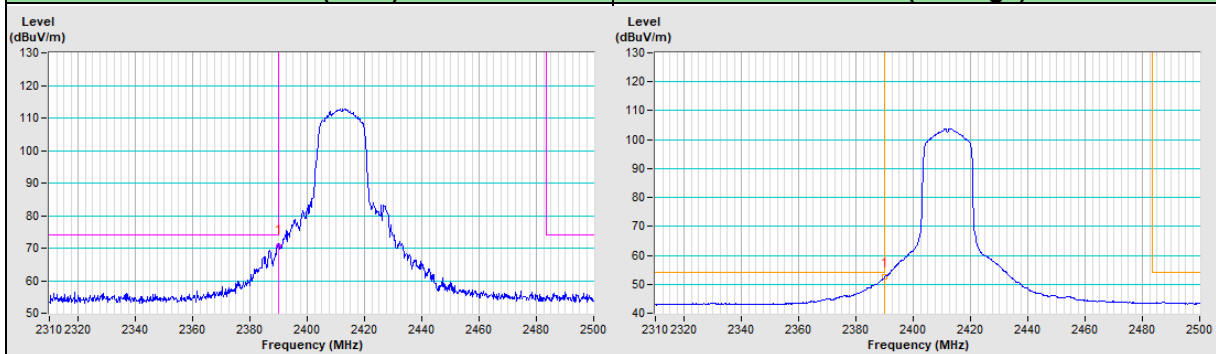

802.11g Channel 11

Horizontal (Peak)	Horizontal (Average)
--------------------------	-----------------------------

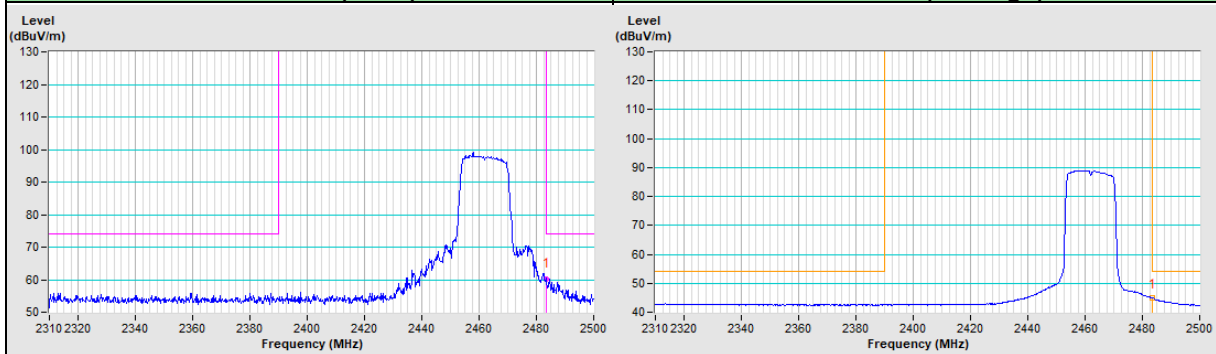

Vertical (Peak)	Vertical (Average)
------------------------	---------------------------

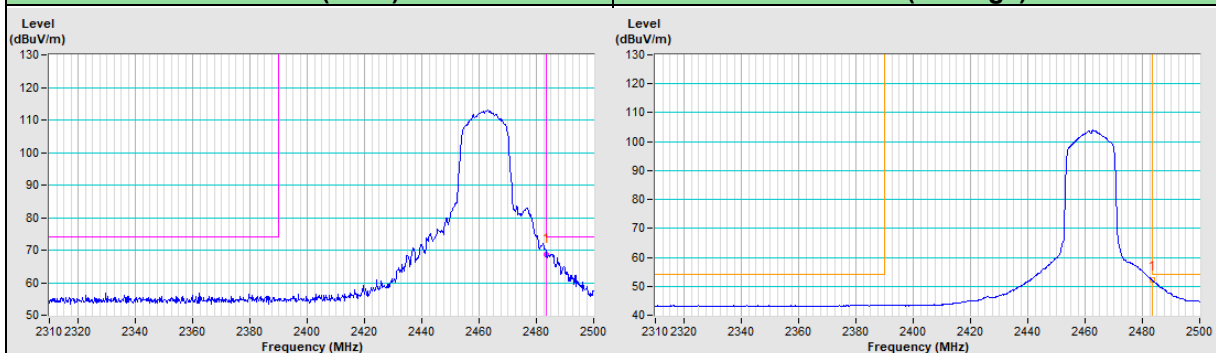

802.11g Channel 12

Horizontal (Peak)	Horizontal (Average)
-------------------	----------------------

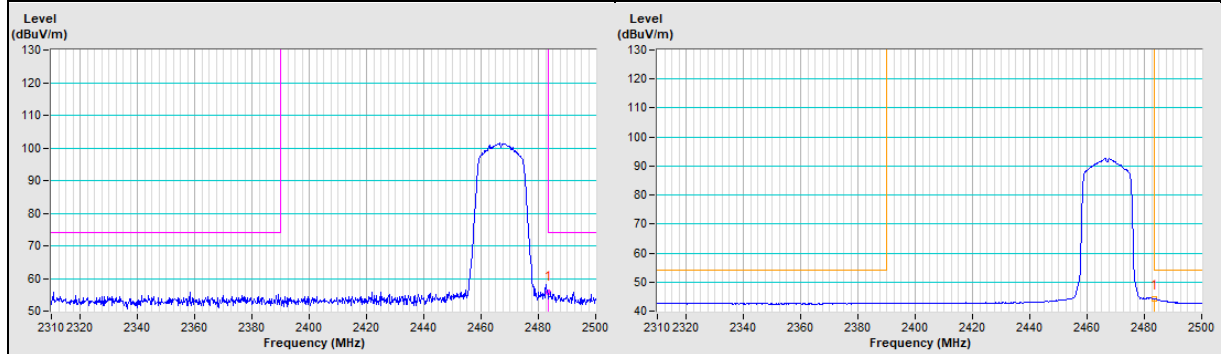

Vertical (Peak)	Vertical (Average)
-----------------	--------------------

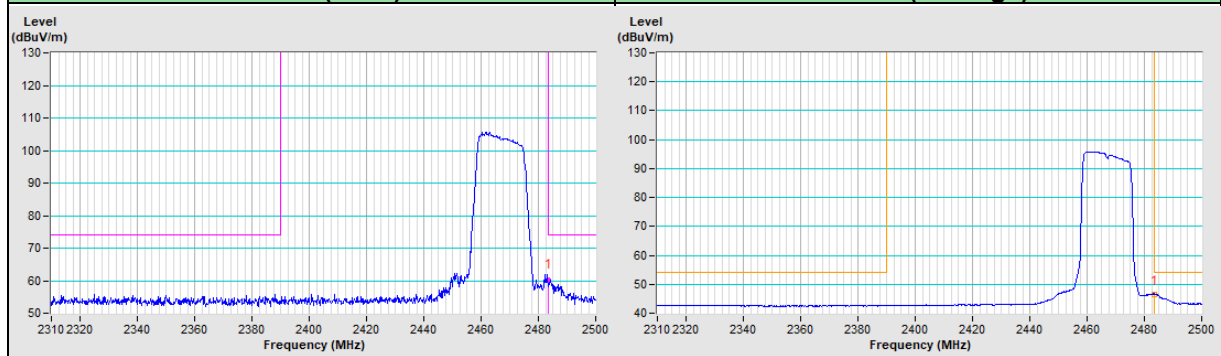

802.11g Channel 13

Horizontal (Peak)	Horizontal (Average)
-------------------	----------------------

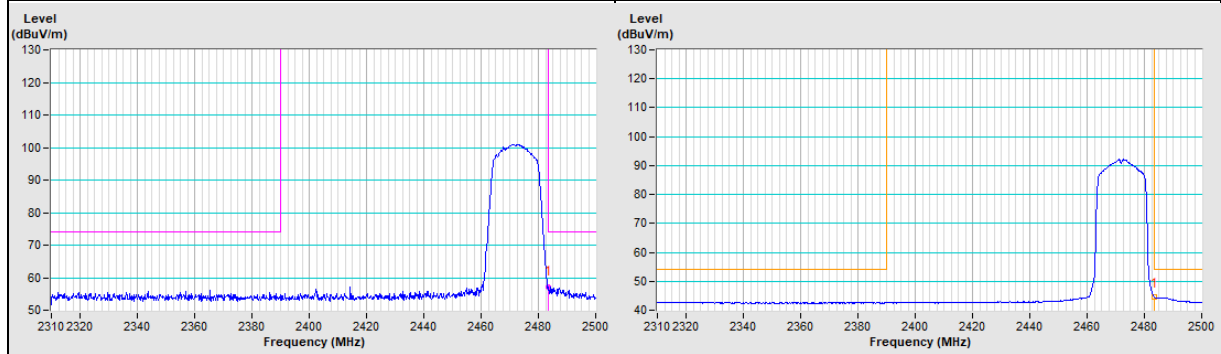

Vertical (Peak)	Vertical (Average)
-----------------	--------------------

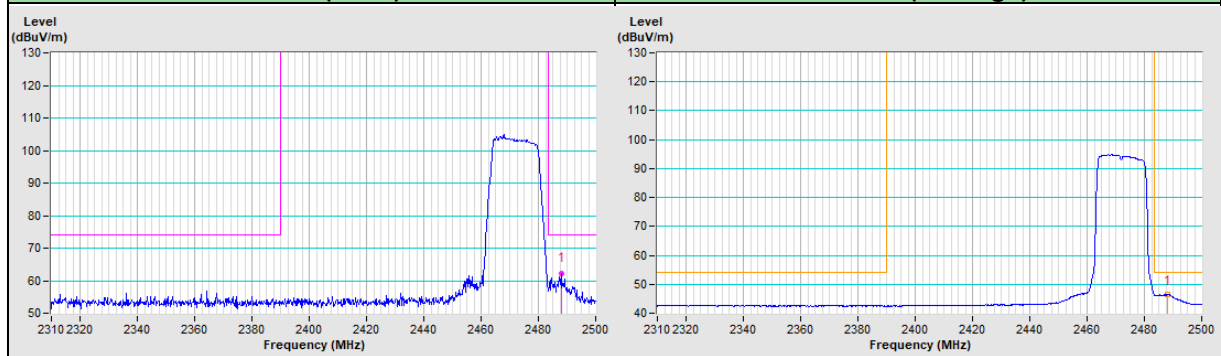

802.11ax (HE20) Channel 1

Horizontal (Peak)	Horizontal (Average)
-------------------	----------------------

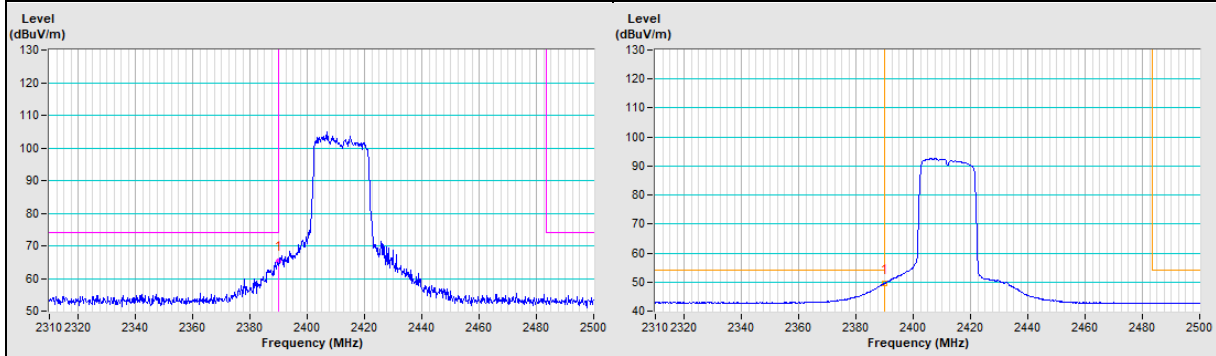

Vertical (Peak)	Vertical (Average)
-----------------	--------------------

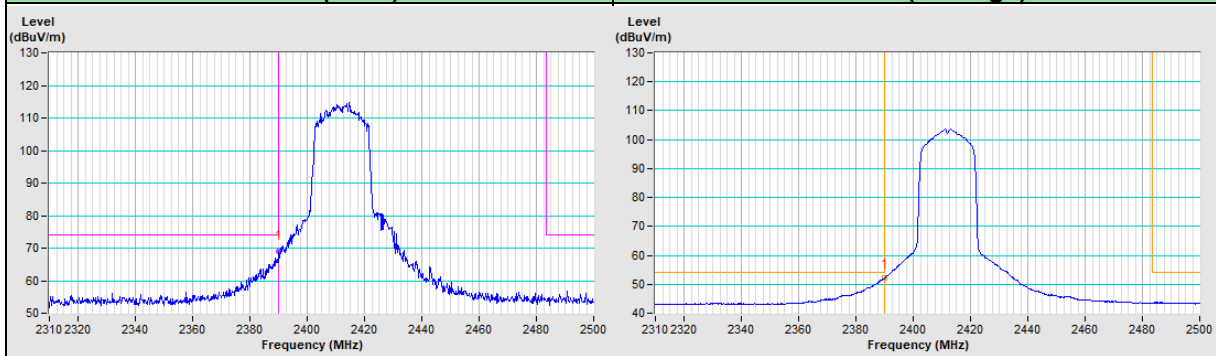

802.11ax (HE20) Channel 11

Horizontal (Peak)	Horizontal (Average)
-------------------	----------------------

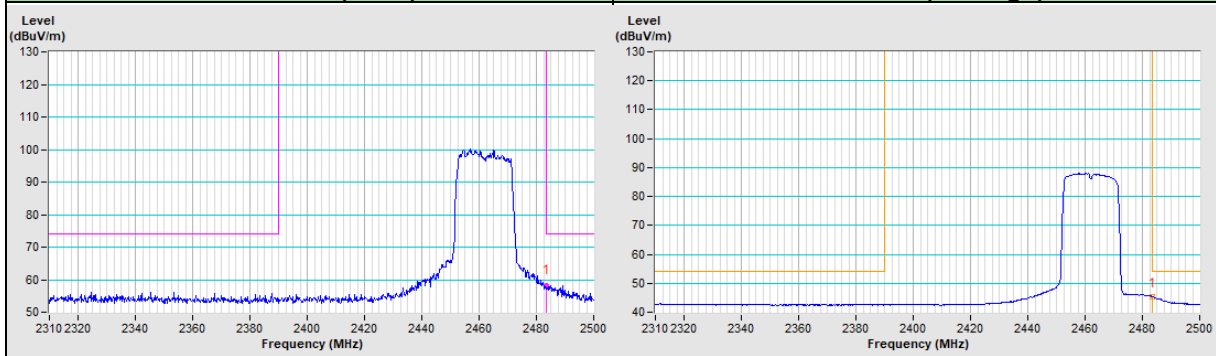

Vertical (Peak)	Vertical (Average)
-----------------	--------------------

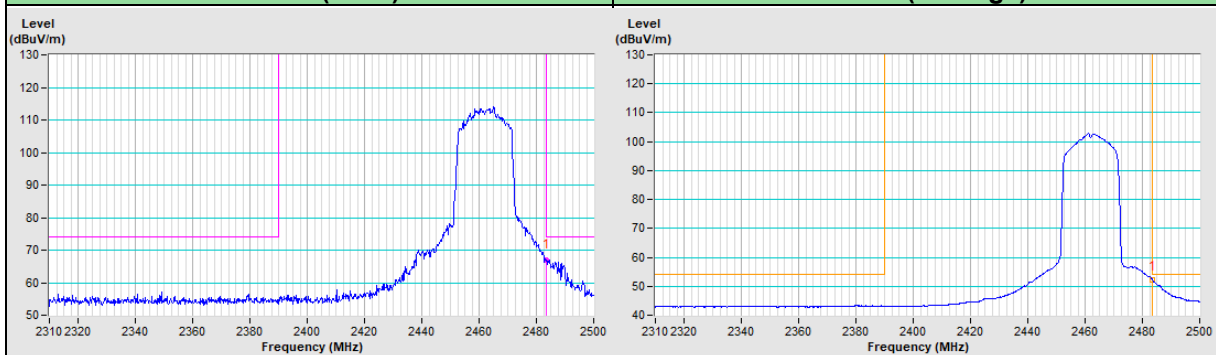

802.11ax (HE20) Channel 12

Horizontal (Peak)	Horizontal (Average)
-------------------	----------------------

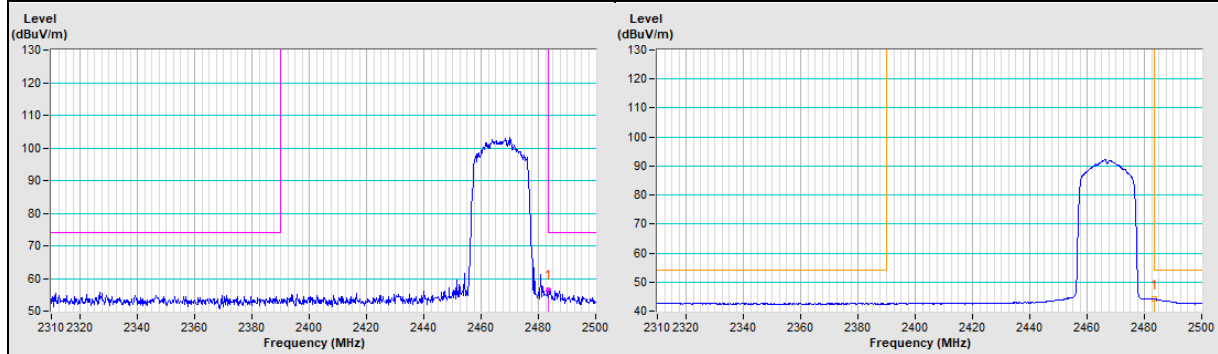

Vertical (Peak)	Vertical (Average)
-----------------	--------------------

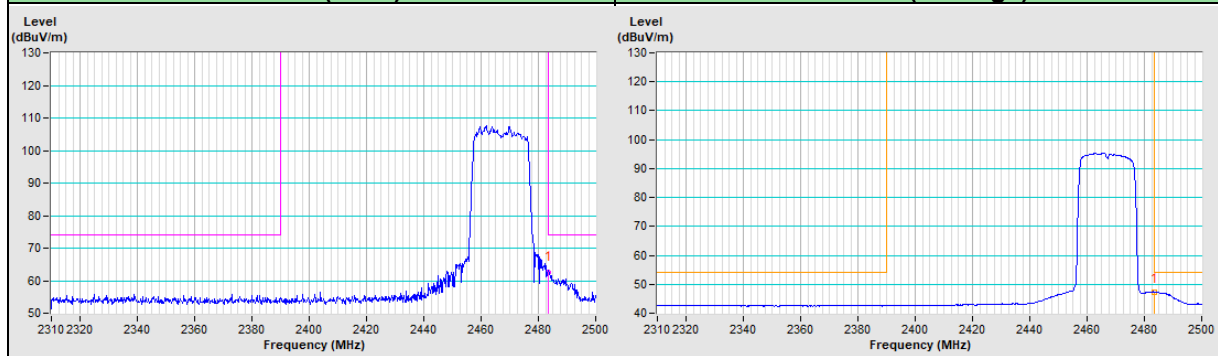

802.11ax (HE20) Channel 13

Horizontal (Peak)	Horizontal (Average)
-------------------	----------------------

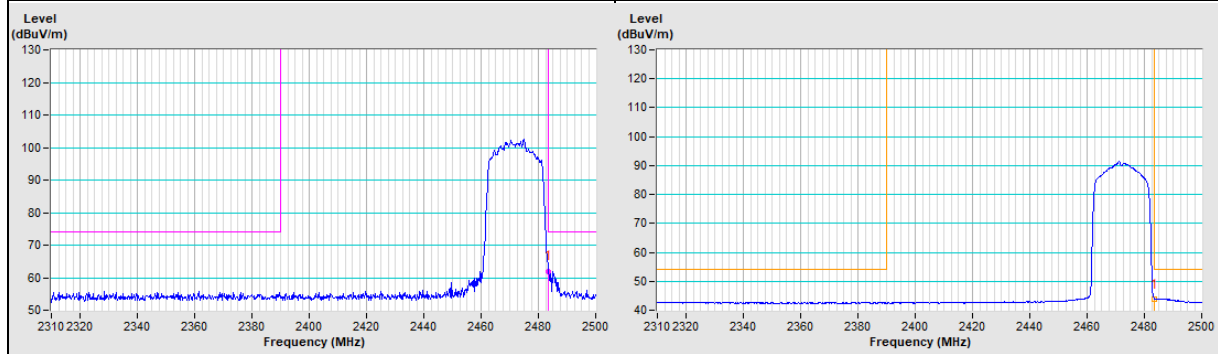

Vertical (Peak)	Vertical (Average)
-----------------	--------------------

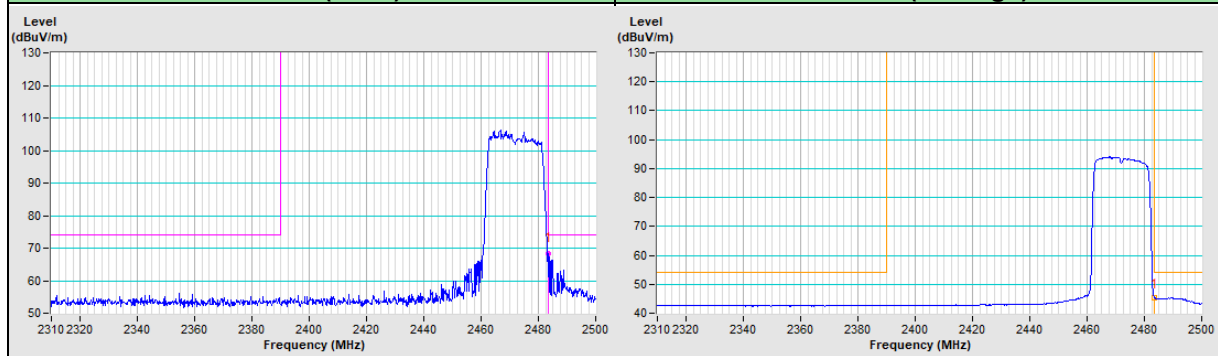

802.11ax (HE40) Channel 3

Horizontal (Peak)

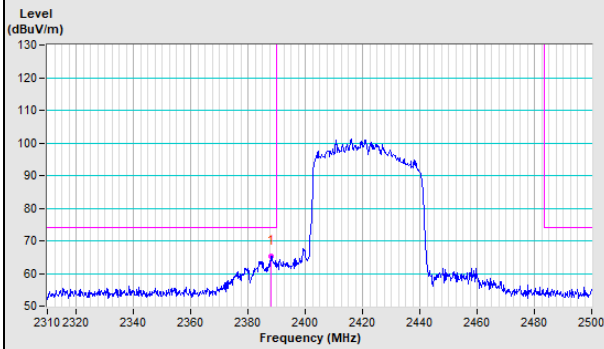

Horizontal (Average)

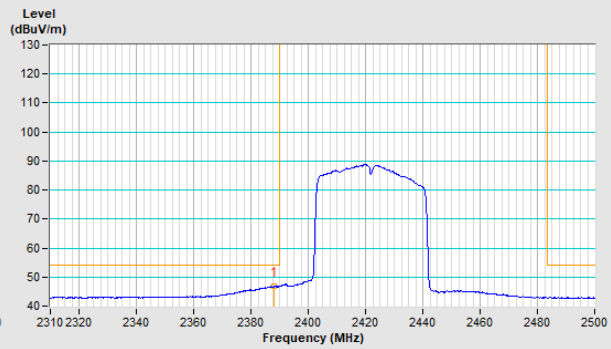

Vertical (Peak)

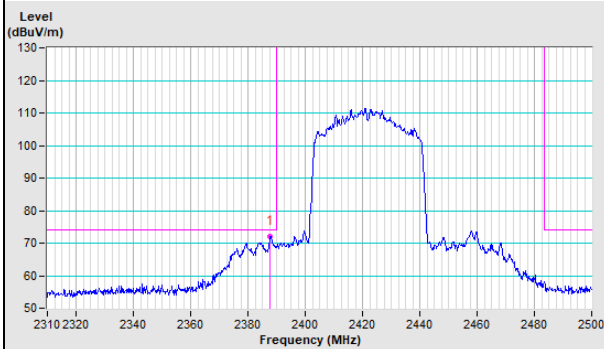

Vertical (Average)

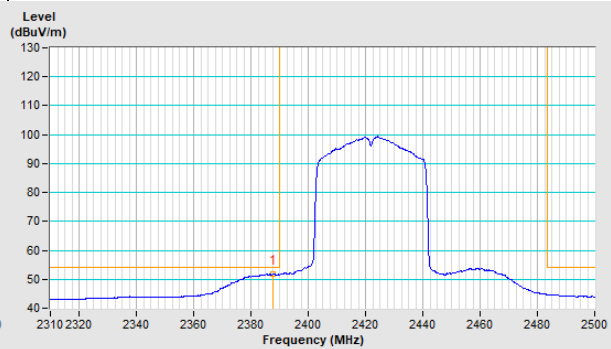

802.11ax (HE40) Channel 9

Horizontal (Peak)

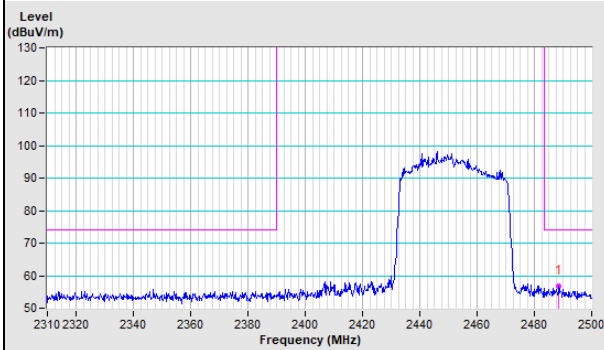

Horizontal (Average)

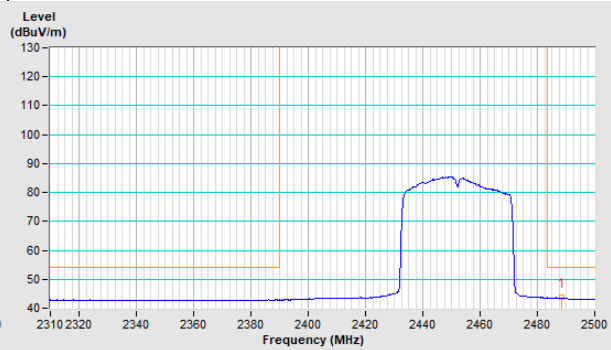

Vertical (Peak)

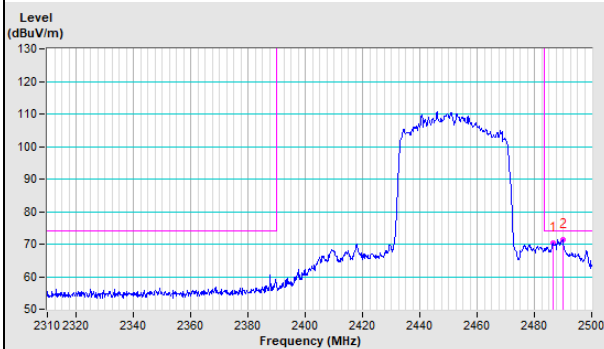

Vertical (Average)

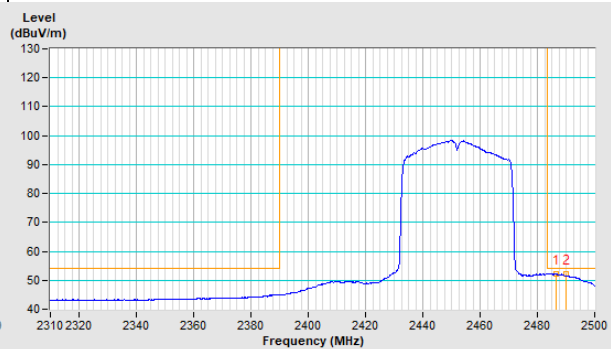

802.11ax (HE40) Channel 10

Horizontal (Peak)	Horizontal (Average)
-------------------	----------------------

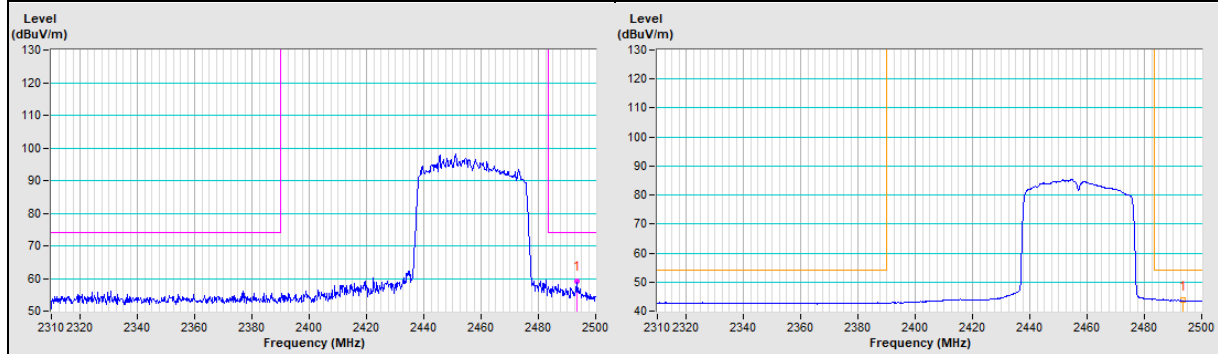

Vertical (Peak)	Vertical (Average)
-----------------	--------------------

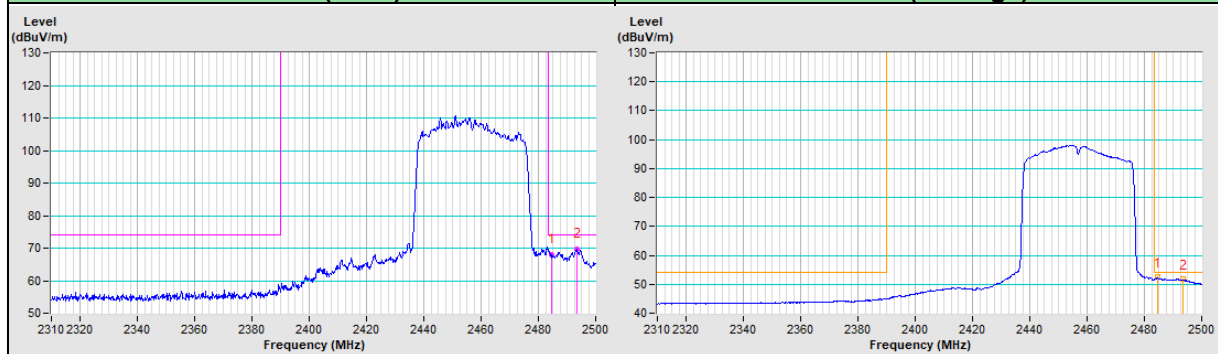

802.11ax (HE40) Channel 11

Horizontal (Peak)	Horizontal (Average)
-------------------	----------------------

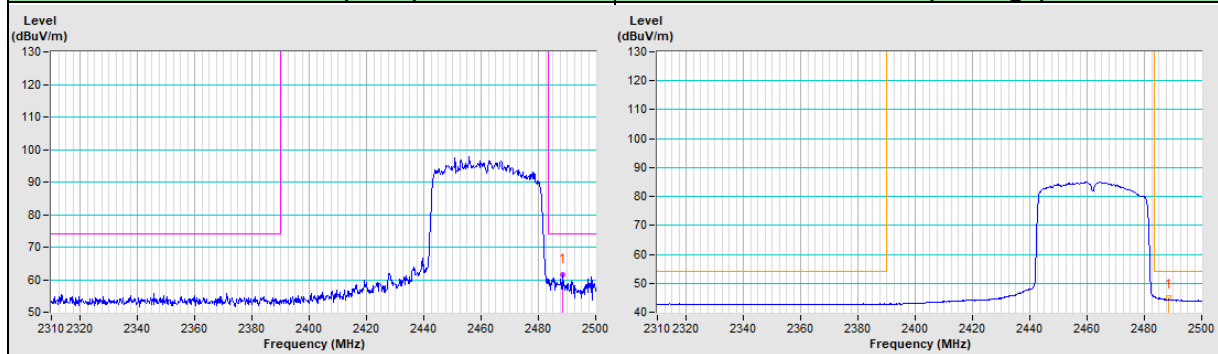

Vertical (Peak)	Vertical (Average)
-----------------	--------------------

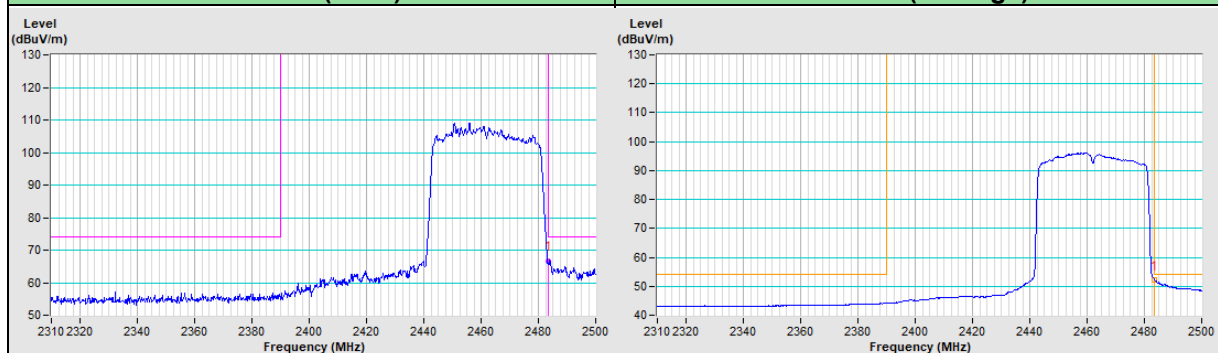

20MHz Preamble 802.11ax (RU26) Channel 1

Horizontal (Peak)

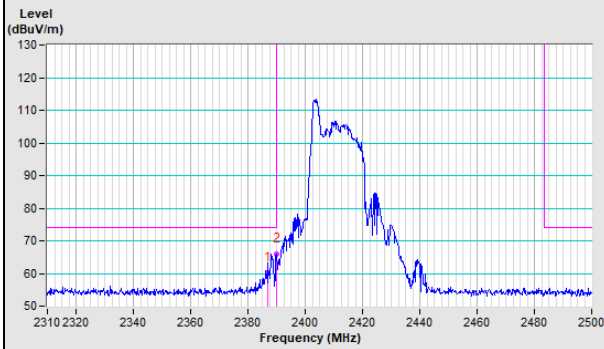

Horizontal (Average)

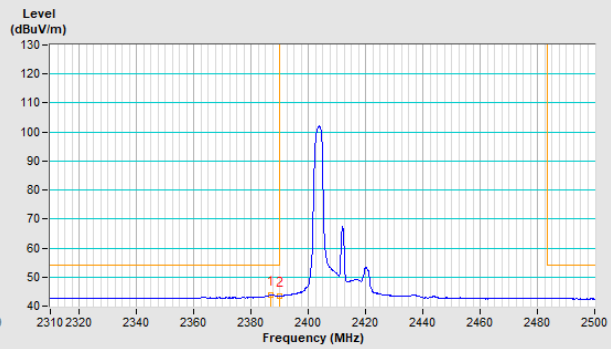

Vertical (Peak)

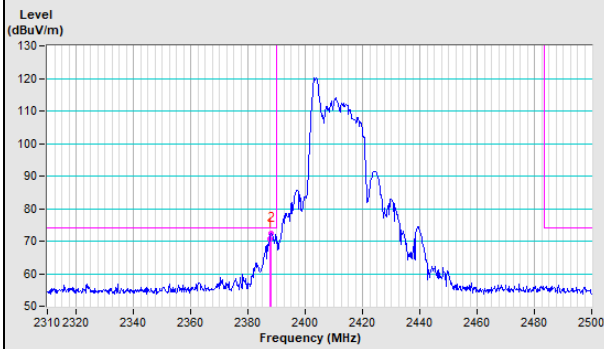

Vertical (Average)

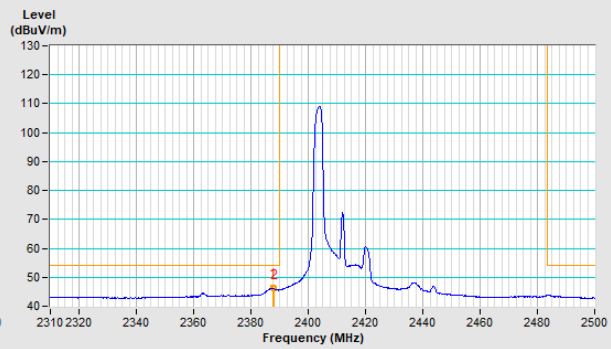

20MHz Preamble 802.11ax (RU26) Channel 11

Horizontal (Peak)

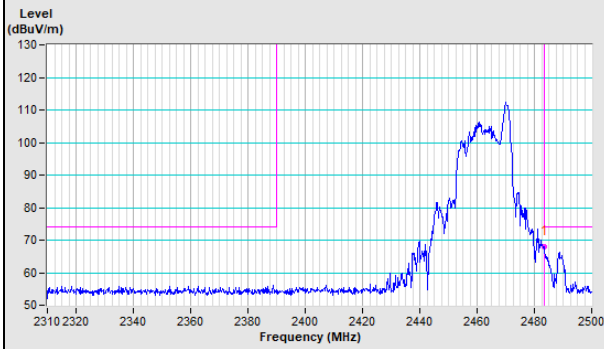

Horizontal (Average)

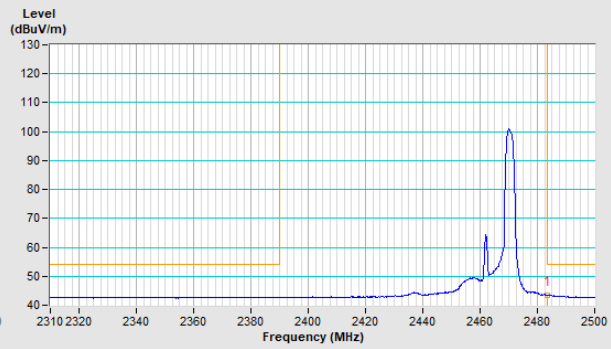

Vertical (Peak)

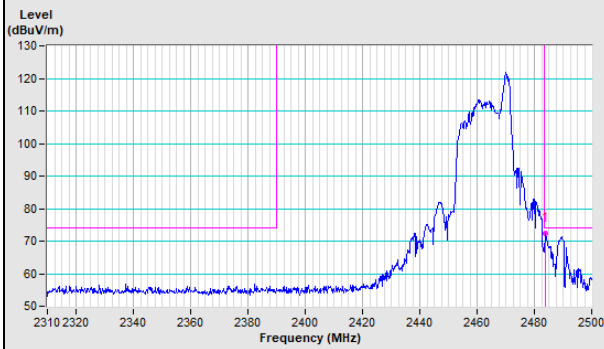

Vertical (Average)

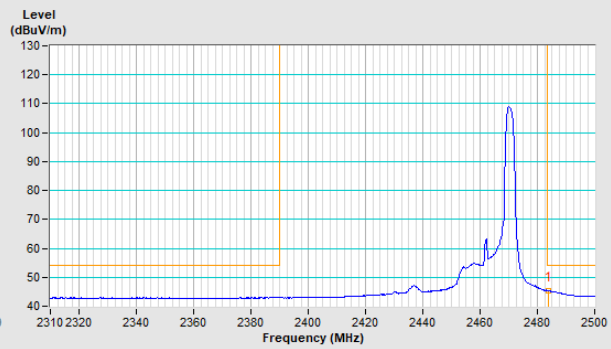

20MHz Preamble 802.11ax (RU26) Channel 12

Horizontal (Peak)

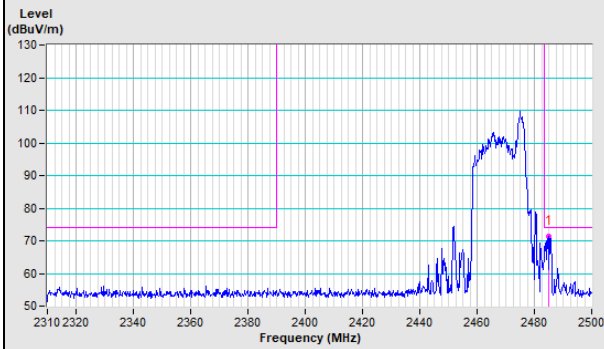

Horizontal (Average)

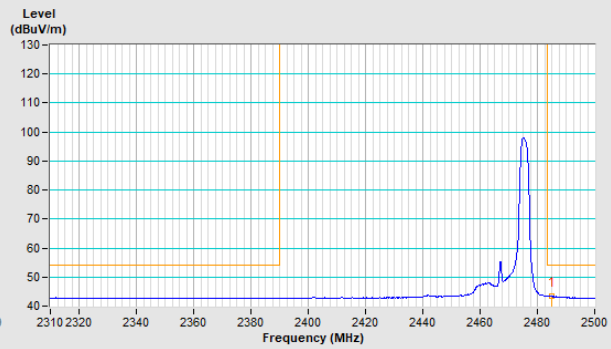

Vertical (Peak)

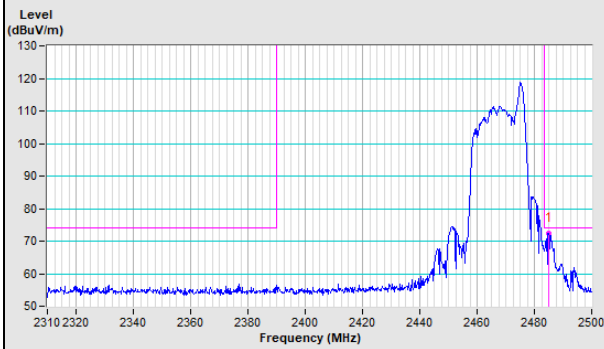

Vertical (Average)

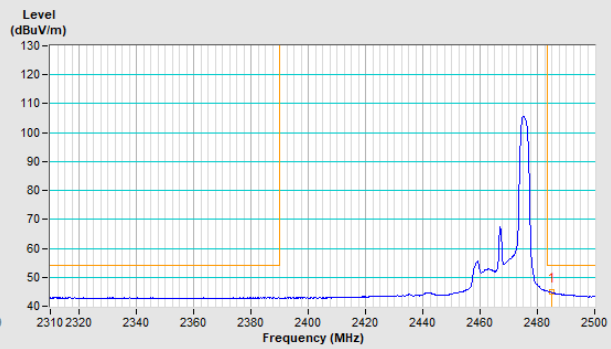

20MHz Preamble 802.11ax (RU26) Channel 13

Horizontal (Peak)

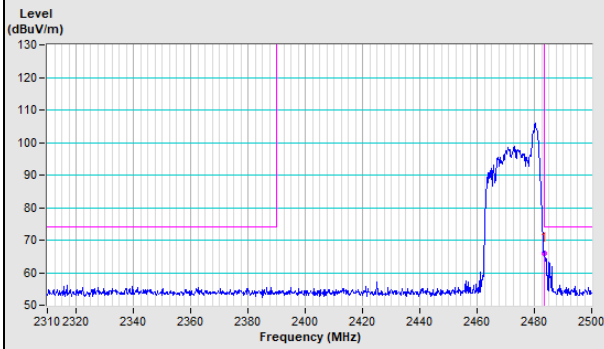

Horizontal (Average)

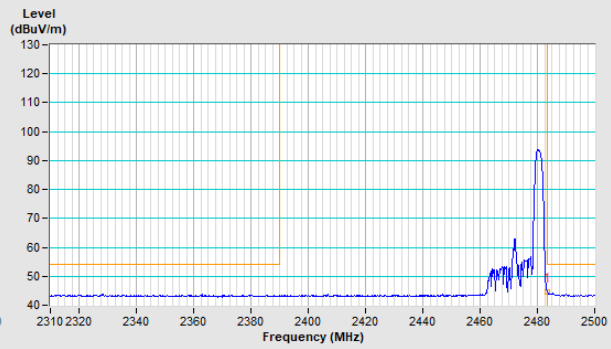

Vertical (Peak)

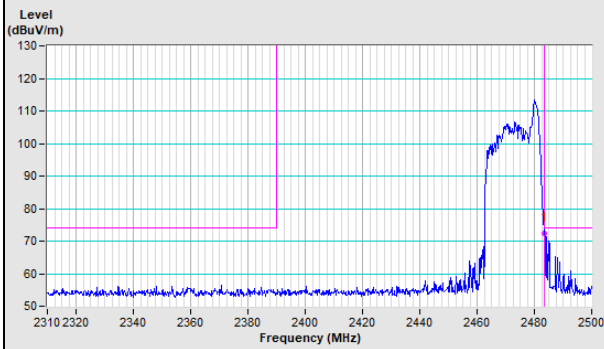

Vertical (Average)

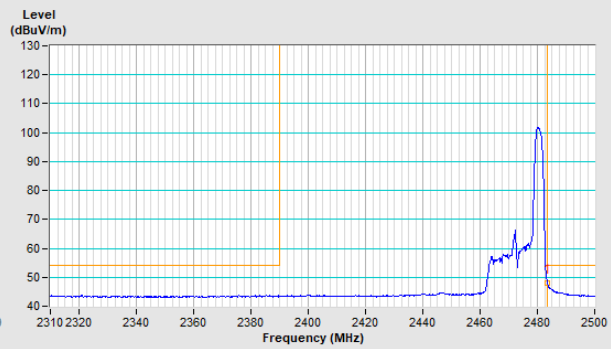

20MHz Preamble 802.11ax (RU52) Channel 1

Horizontal (Peak)	Horizontal (Average)
--------------------------	-----------------------------

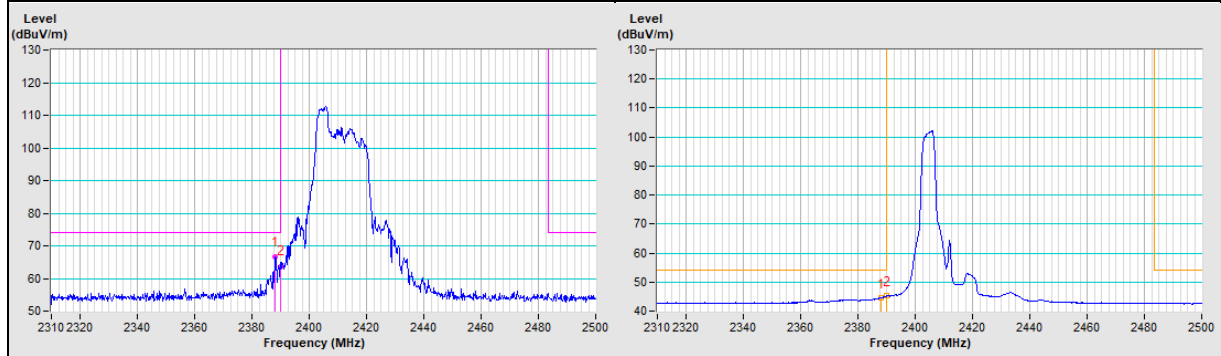

Vertical (Peak)	Vertical (Average)
------------------------	---------------------------

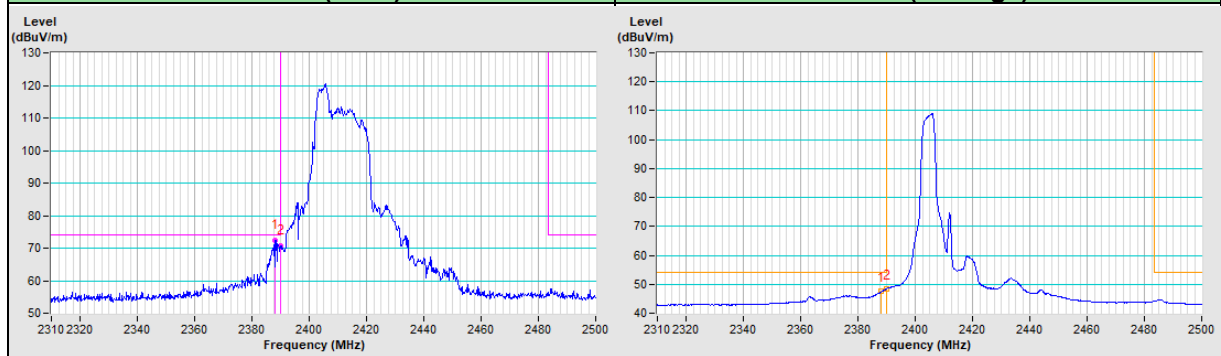

20MHz Preamble 802.11ax (RU52) Channel 11

Horizontal (Peak)	Horizontal (Average)
--------------------------	-----------------------------

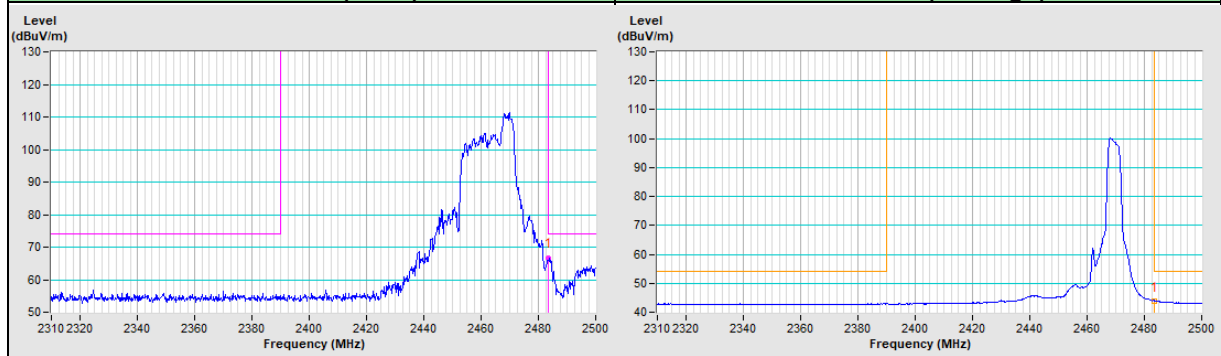

Vertical (Peak)	Vertical (Average)
------------------------	---------------------------

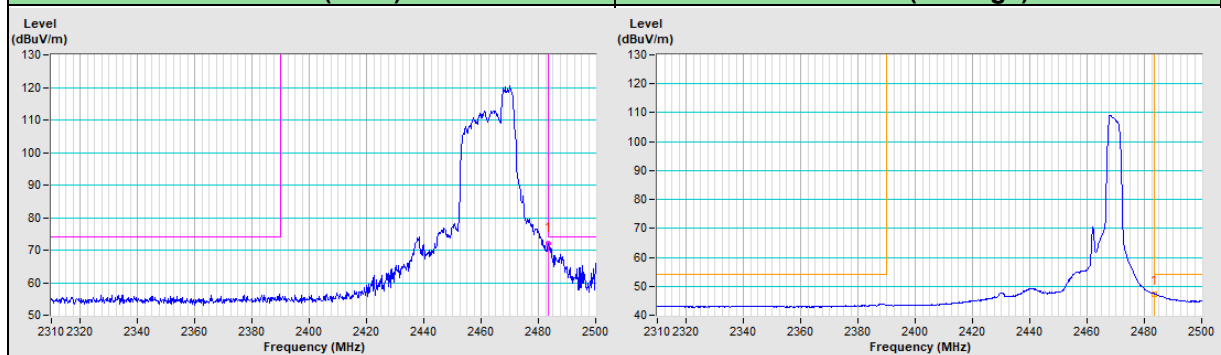

20MHz Preamble 802.11ax (RU52) Channel 12

Horizontal (Peak)

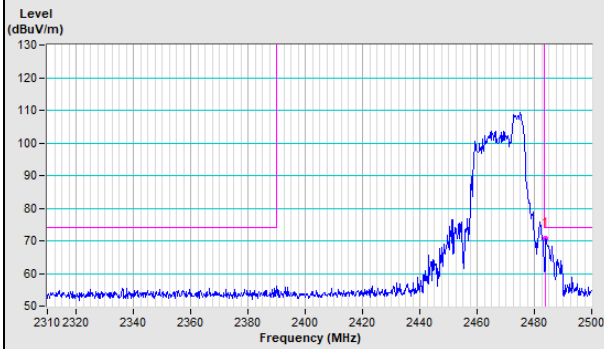

Horizontal (Average)

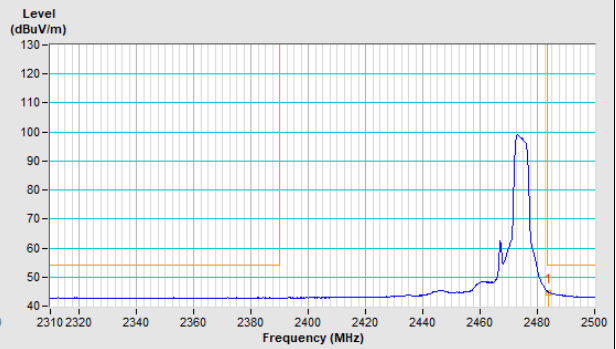

Vertical (Peak)

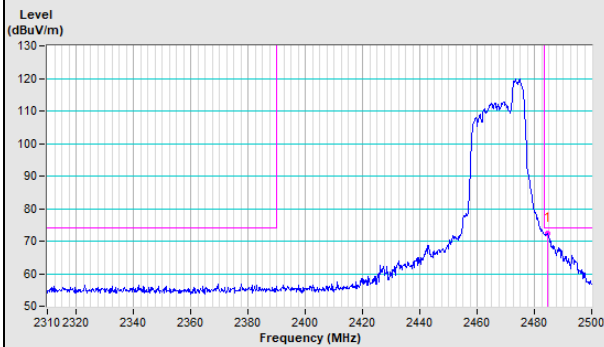

Vertical (Average)

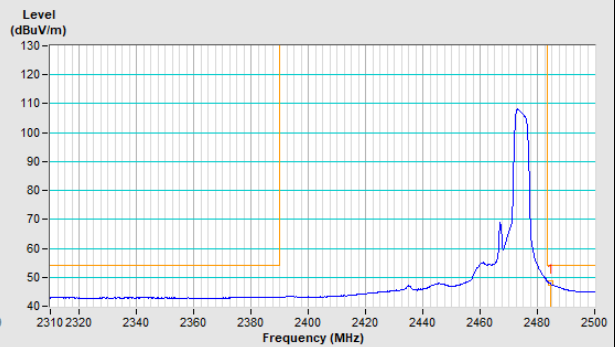

20MHz Preamble 802.11ax (RU52) Channel 13

Horizontal (Peak)

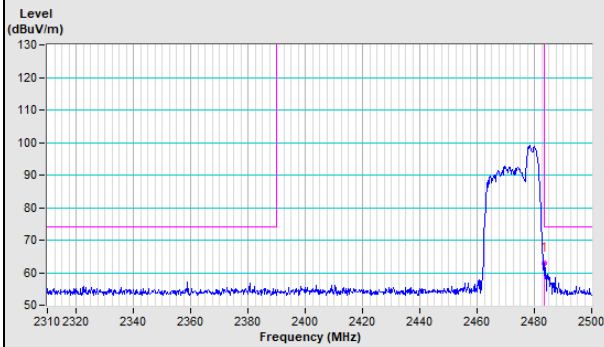

Horizontal (Average)

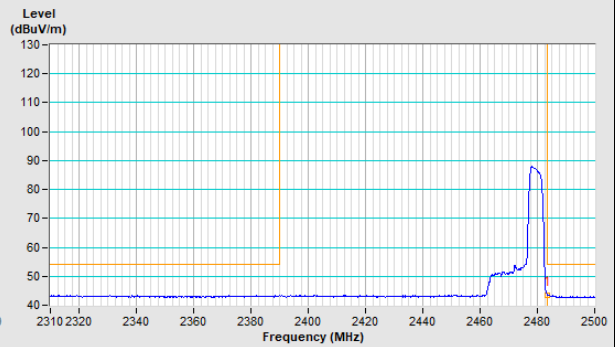

Vertical (Peak)

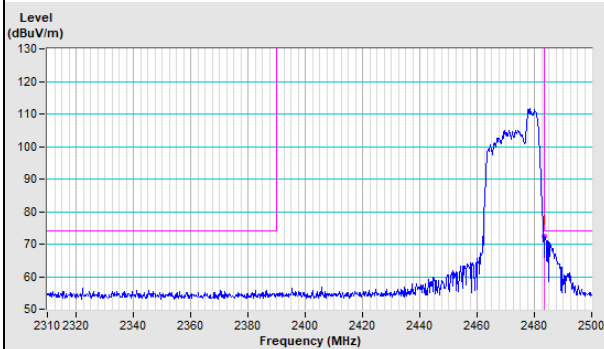

Vertical (Average)

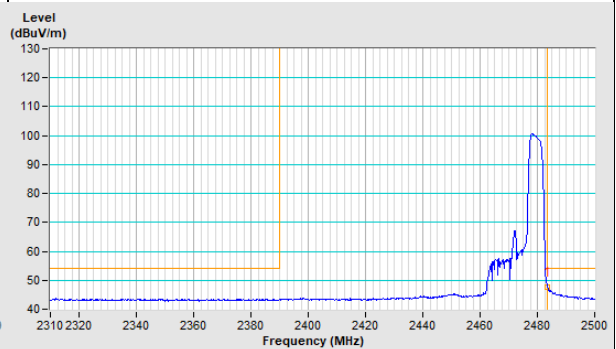

20MHz Preamble 802.11ax (RU106) Channel 1

Horizontal (Peak)	Horizontal (Average)
-------------------	----------------------

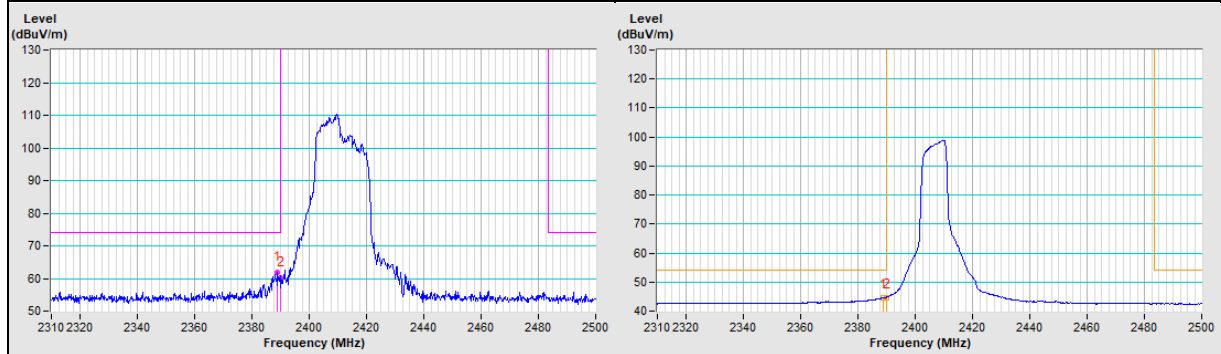

Vertical (Peak)	Vertical (Average)
-----------------	--------------------

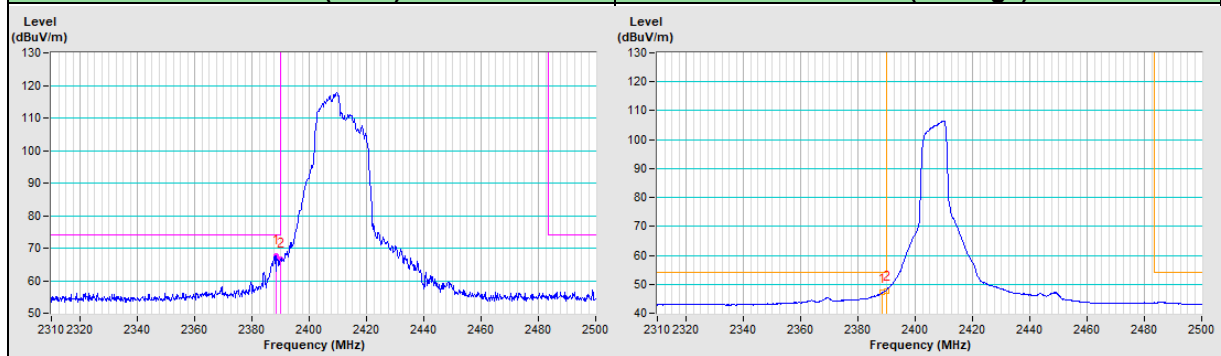

20MHz Preamble 802.11ax (RU106) Channel 11

Horizontal (Peak)	Horizontal (Average)
-------------------	----------------------

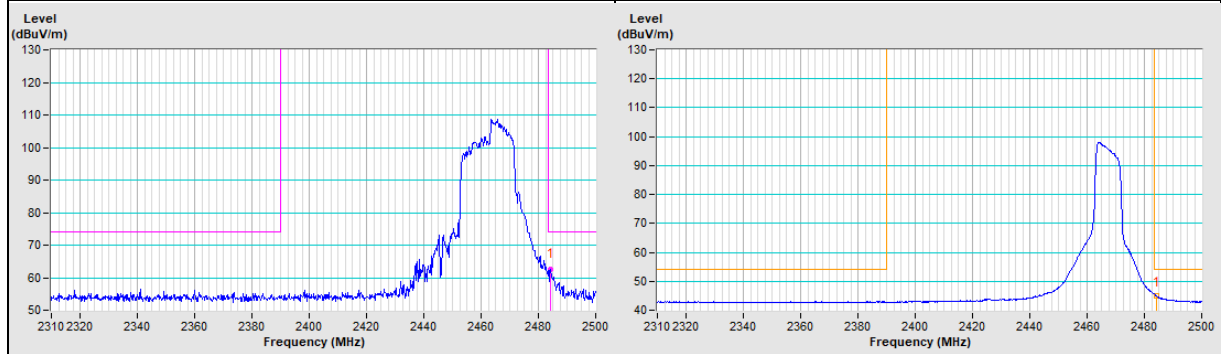

Vertical (Peak)	Vertical (Average)
-----------------	--------------------

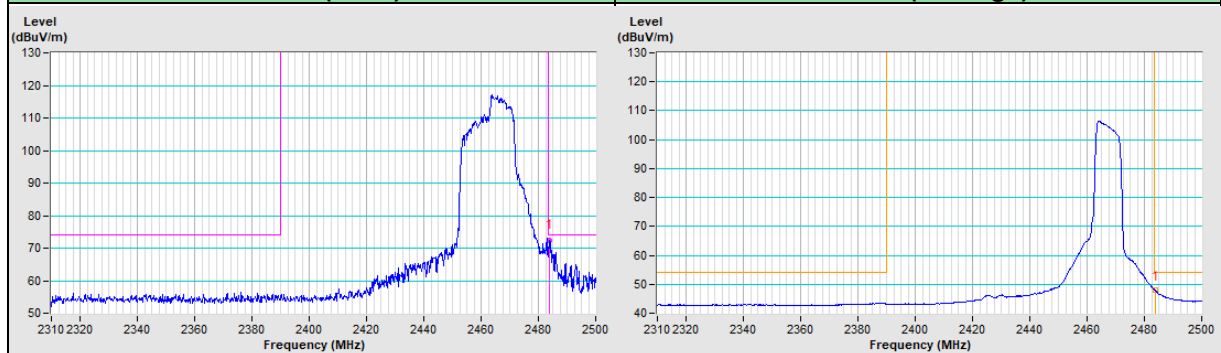

20MHz Preamble 802.11ax (RU106) Channel 12

Horizontal (Peak)

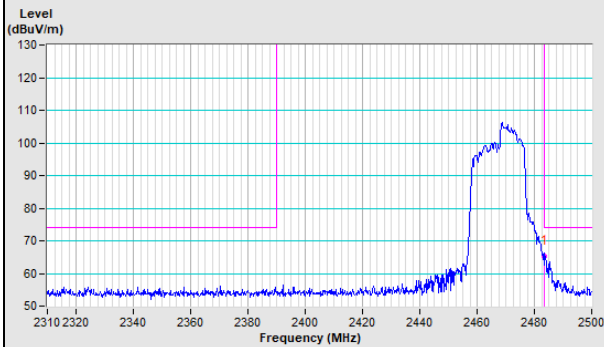

Horizontal (Average)

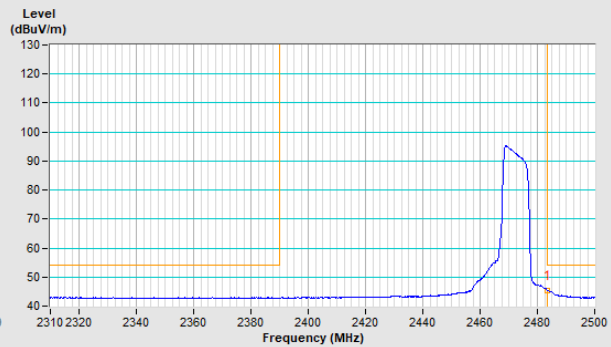

Vertical (Peak)

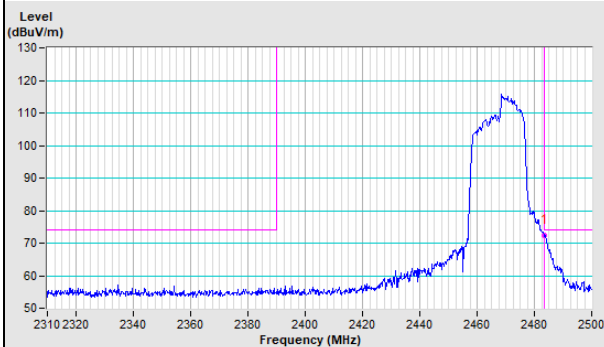

Vertical (Average)

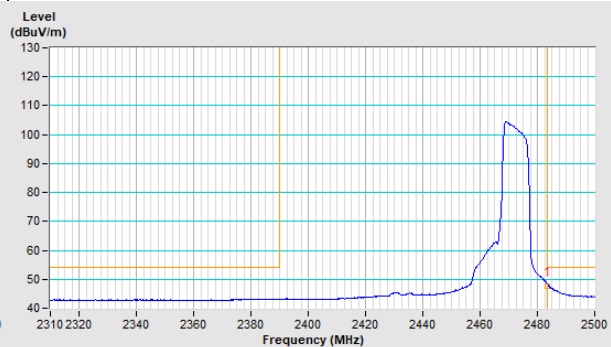

20MHz Preamble 802.11ax (RU106) Channel 13

Horizontal (Peak)

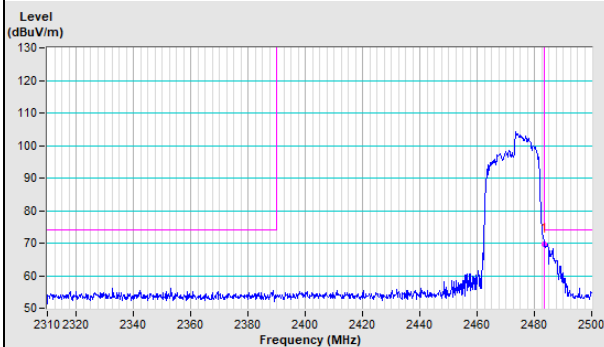

Horizontal (Average)

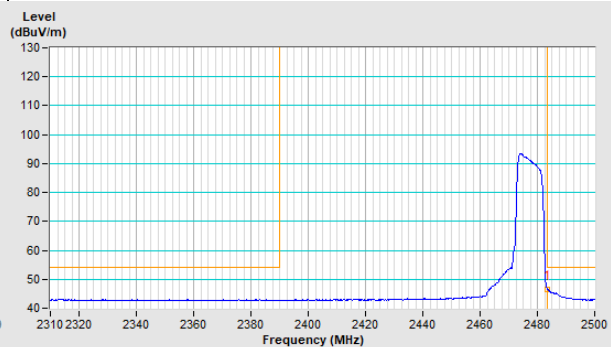

Vertical (Peak)

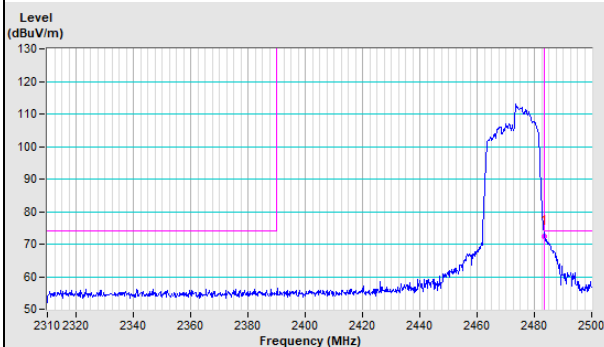

Vertical (Average)

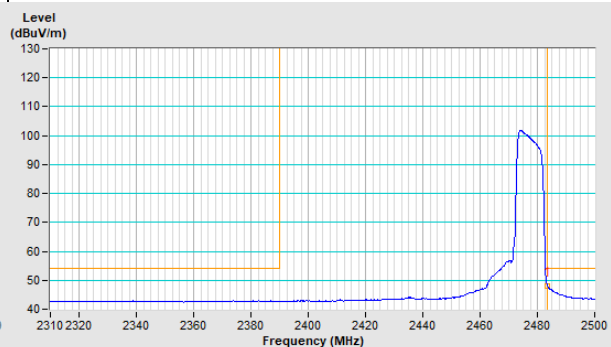

PIFA Antenna

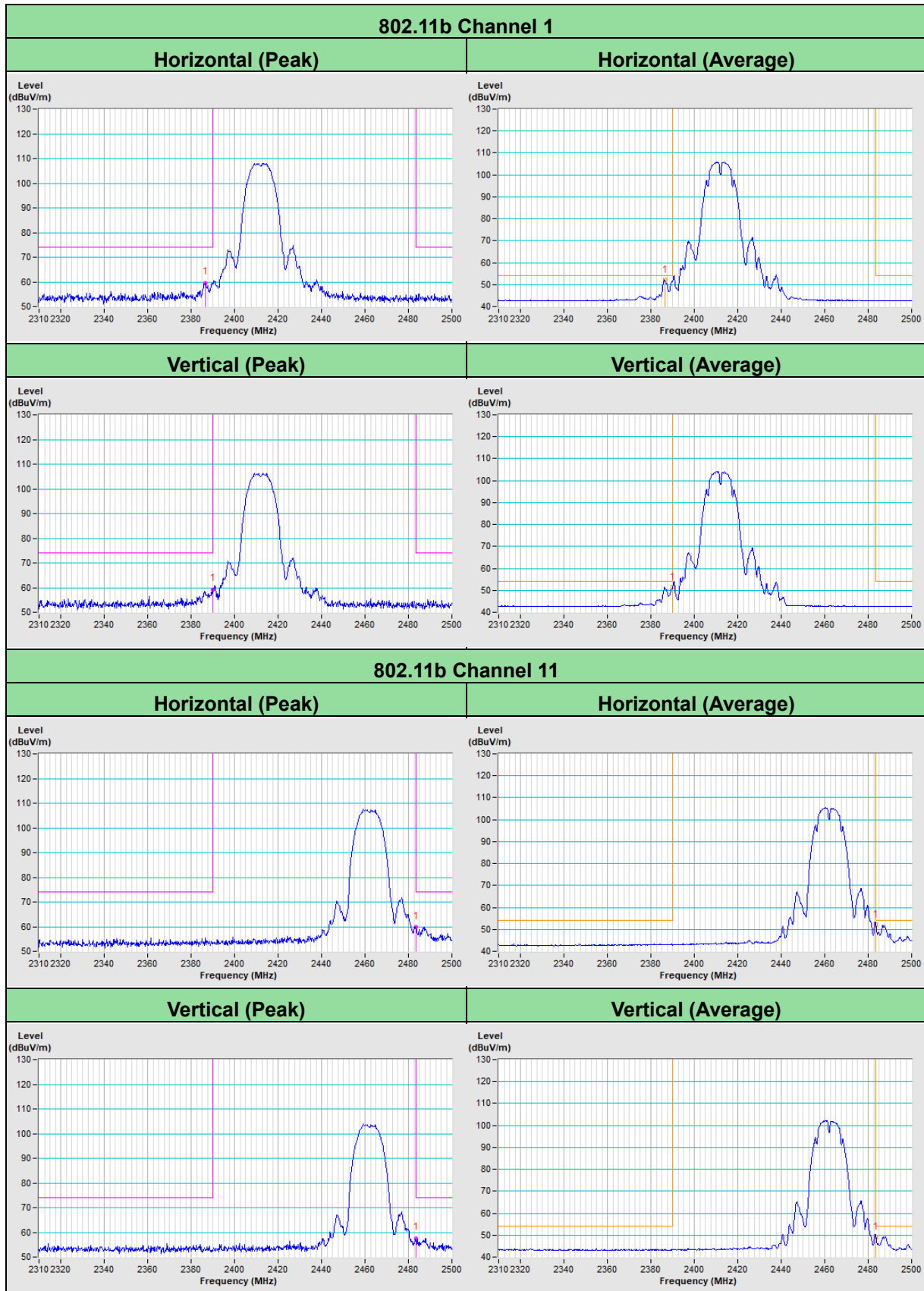

802.11b Channel 12

Horizontal (Peak)	Horizontal (Average)
-------------------	----------------------

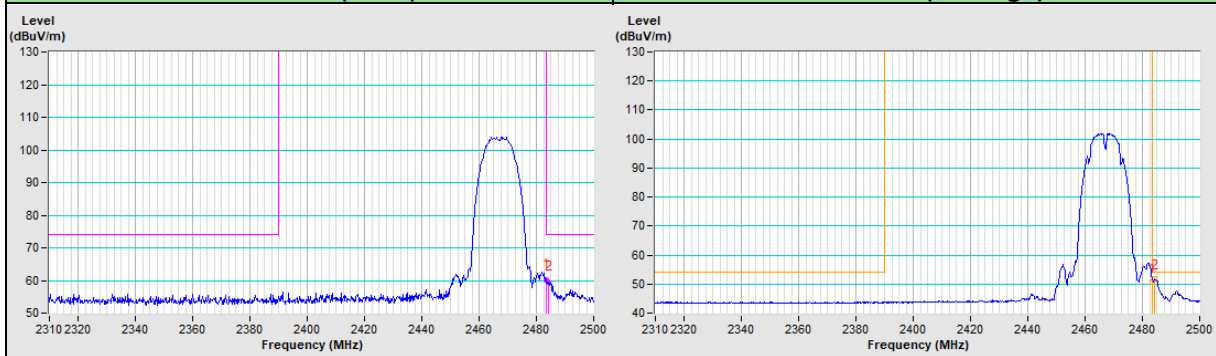

Vertical (Peak)	Vertical (Average)
-----------------	--------------------

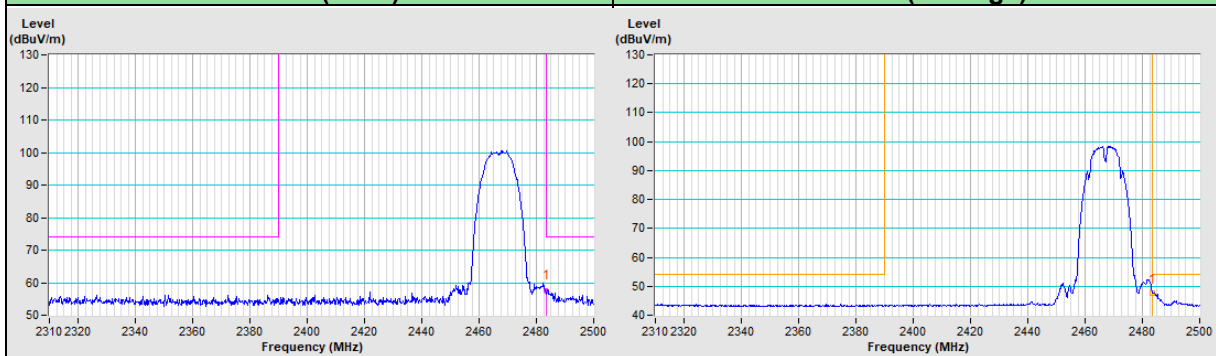

802.11b Channel 13

Horizontal (Peak)	Horizontal (Average)
-------------------	----------------------

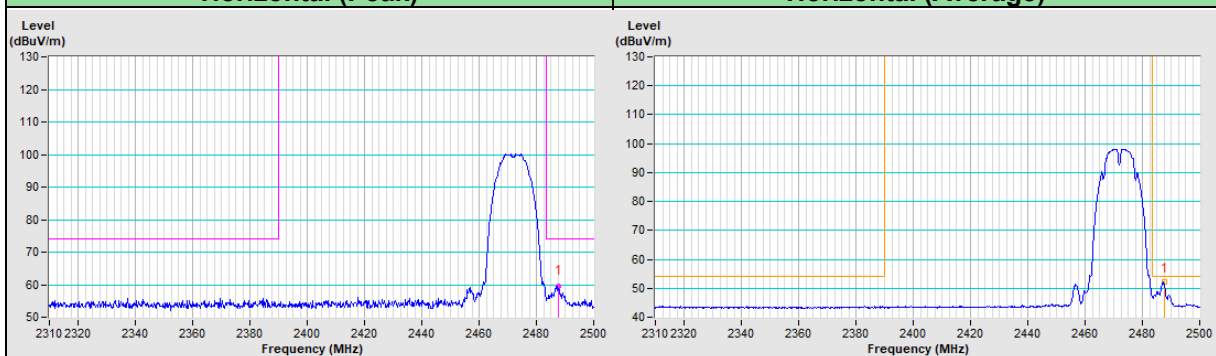

Vertical (Peak)	Vertical (Average)
-----------------	--------------------

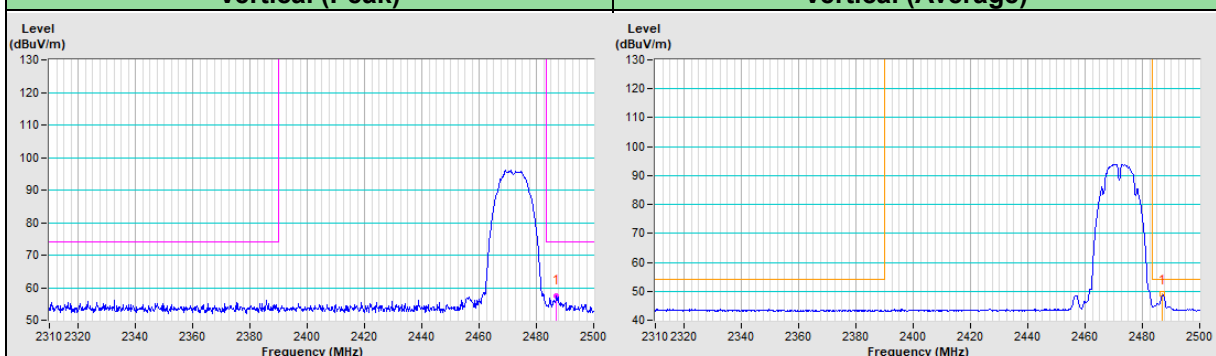

802.11g Channel 1

Horizontal (Peak)	Horizontal (Average)
-------------------	----------------------

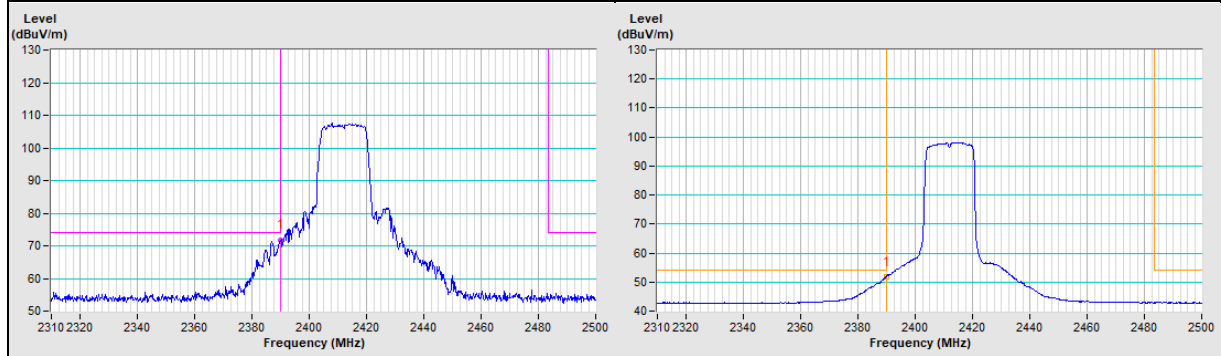

Vertical (Peak)	Vertical (Average)
-----------------	--------------------

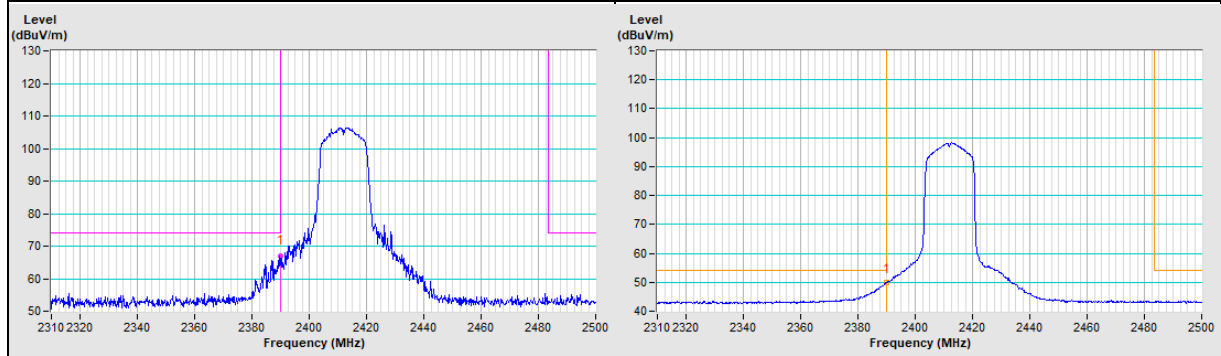

802.11g Channel 11

Horizontal (Peak)	Horizontal (Average)
-------------------	----------------------

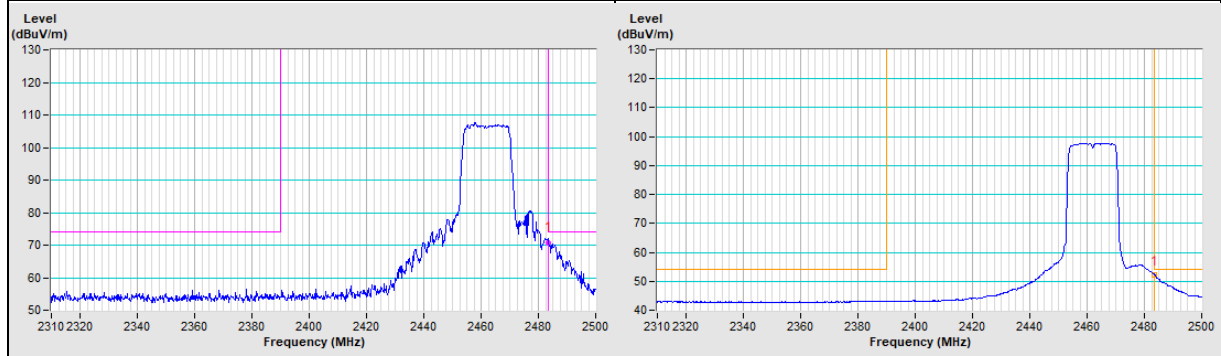

Vertical (Peak)	Vertical (Average)
-----------------	--------------------

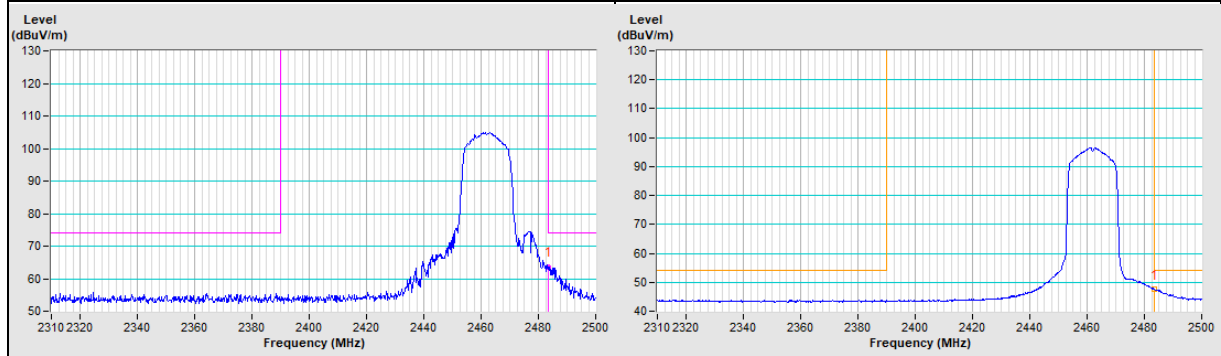

802.11g Channel 12

Horizontal (Peak)	Horizontal (Average)
-------------------	----------------------

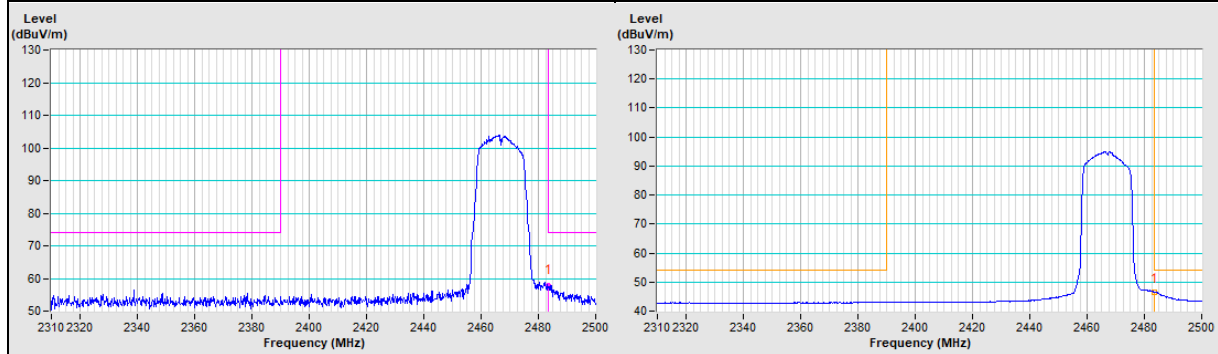

Vertical (Peak)	Vertical (Average)
-----------------	--------------------

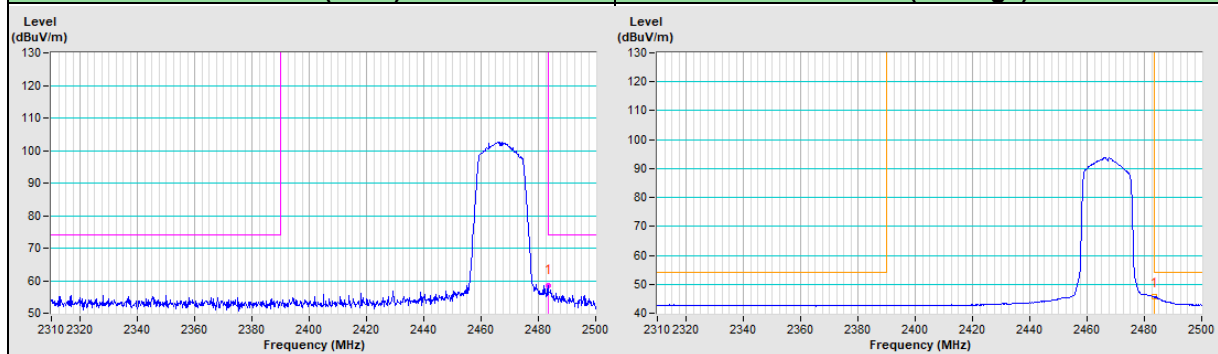

802.11g Channel 13

Horizontal (Peak)	Horizontal (Average)
-------------------	----------------------

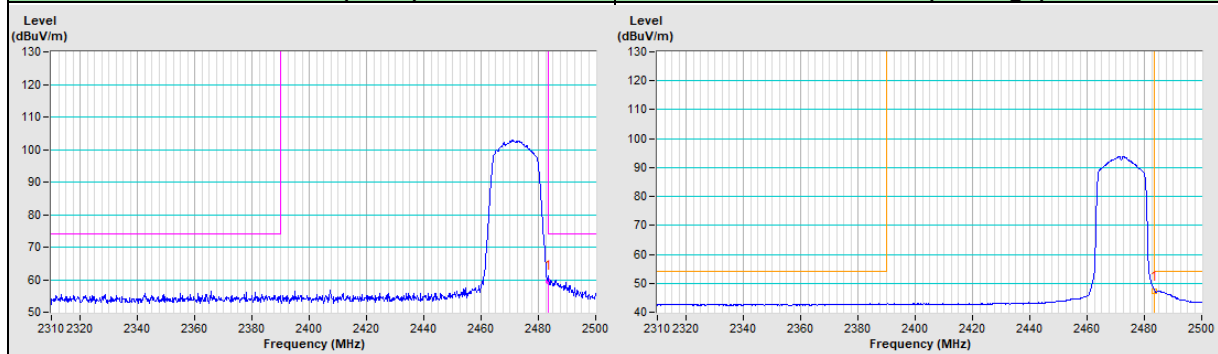

Vertical (Peak)	Vertical (Average)
-----------------	--------------------

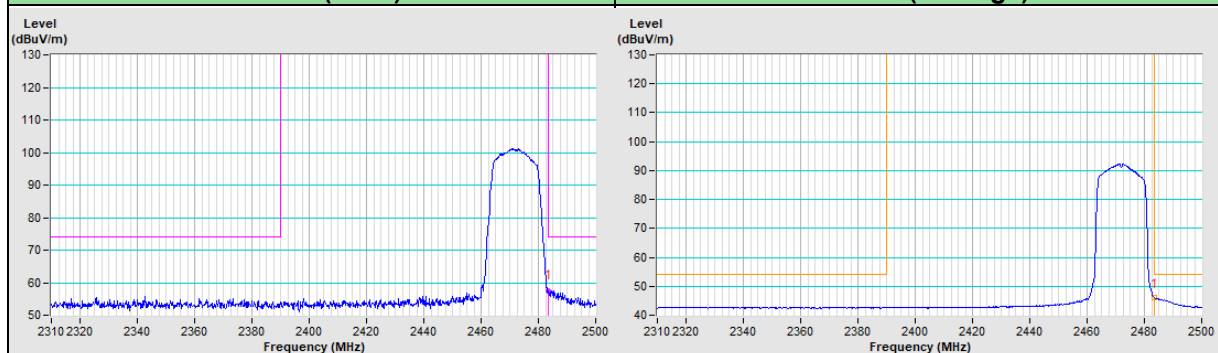

802.11ax (HE20) Channel 1

Horizontal (Peak)

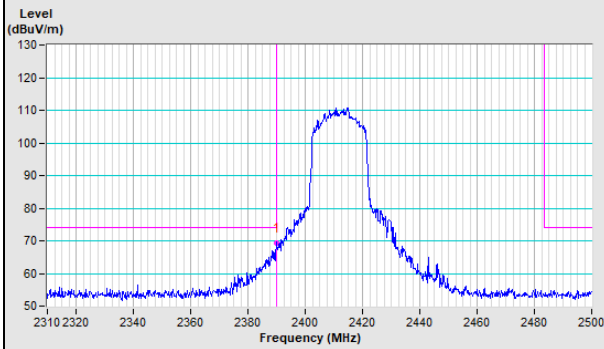

Horizontal (Average)

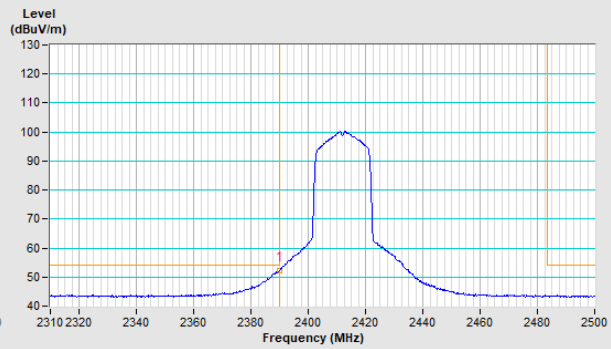

Vertical (Peak)

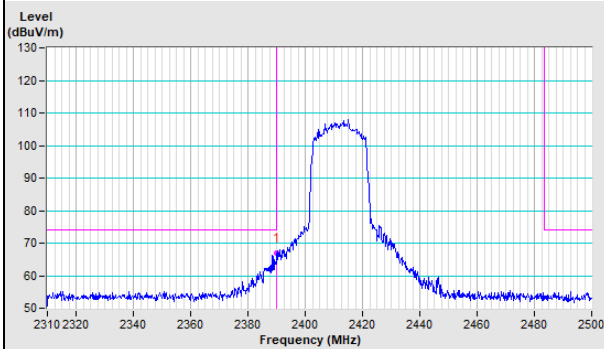

Vertical (Average)

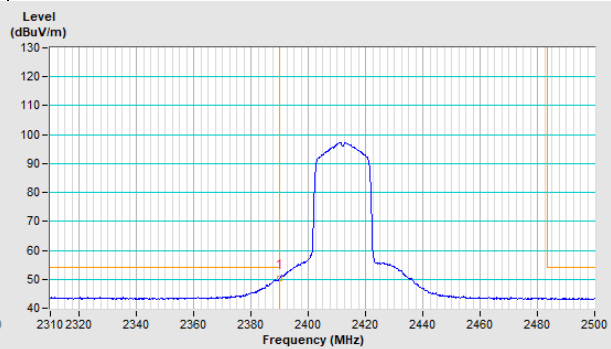

802.11ax (HE20) Channel 11

Horizontal (Peak)

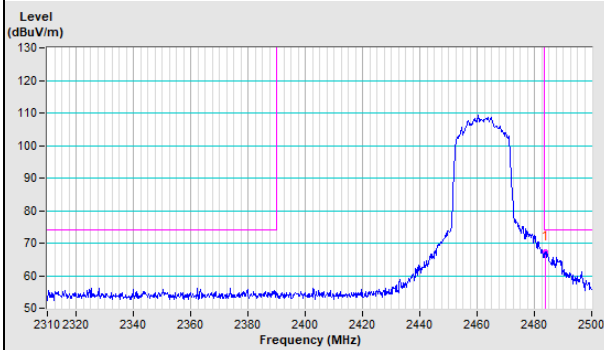

Horizontal (Average)

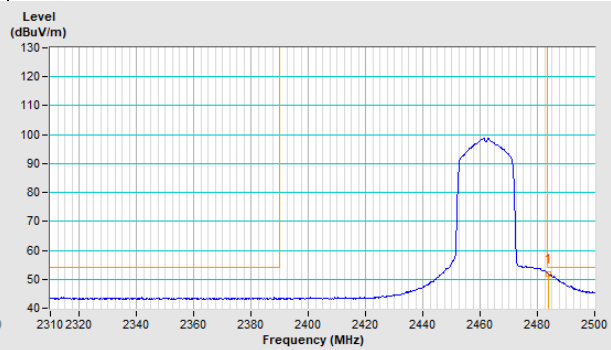

Vertical (Peak)

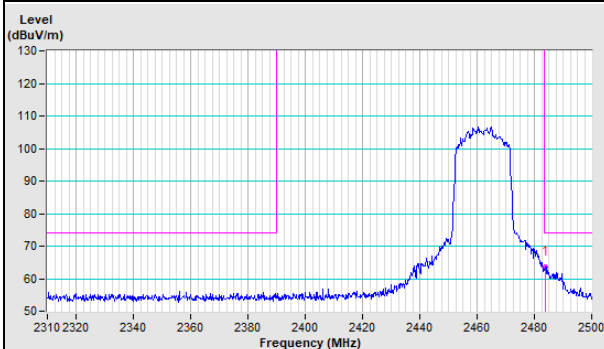

Vertical (Average)

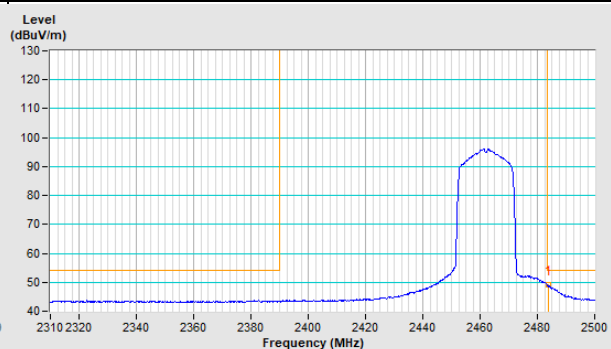

802.11ax (HE20) Channel 12

Horizontal (Peak)	Horizontal (Average)
-------------------	----------------------

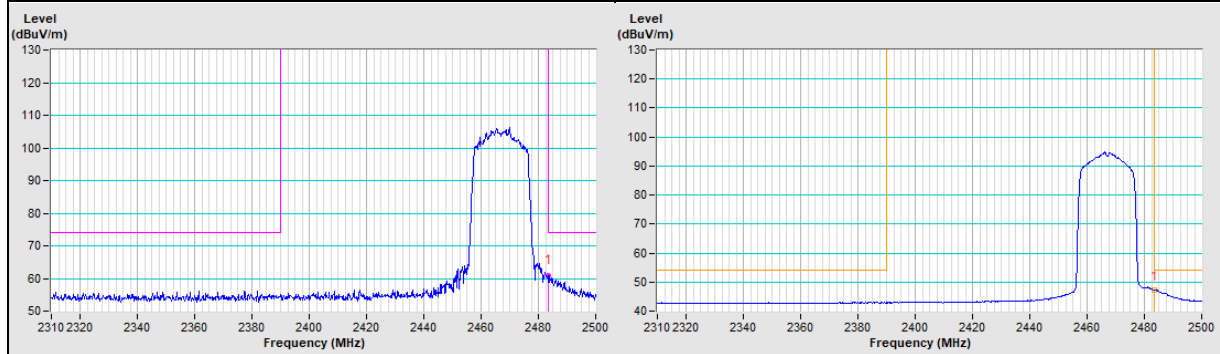

Vertical (Peak)	Vertical (Average)
-----------------	--------------------

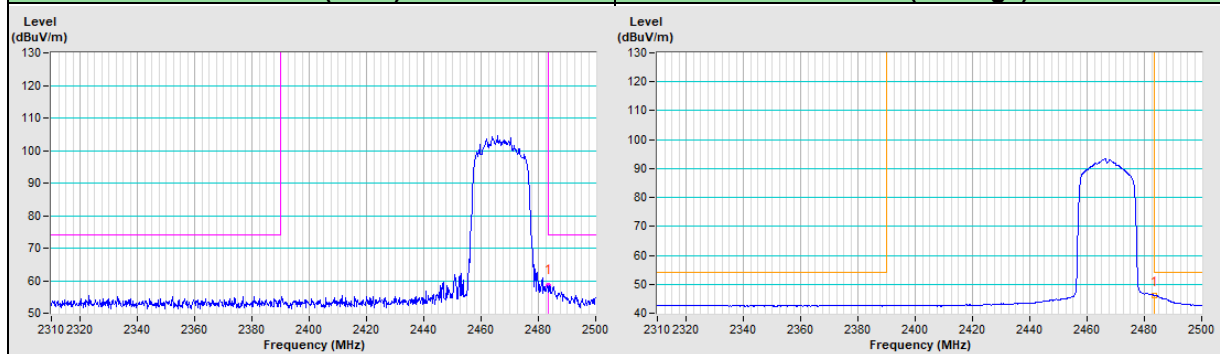

802.11ax (HE20) Channel 13

Horizontal (Peak)	Horizontal (Average)
-------------------	----------------------

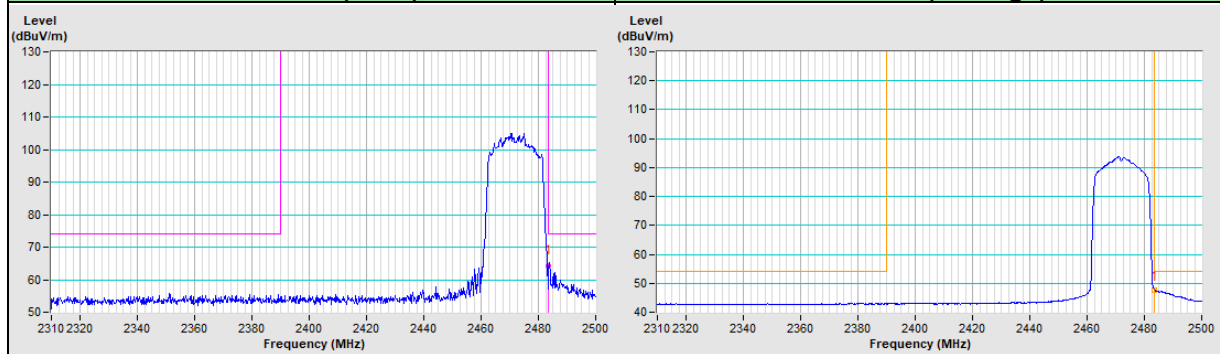

Vertical (Peak)	Vertical (Average)
-----------------	--------------------

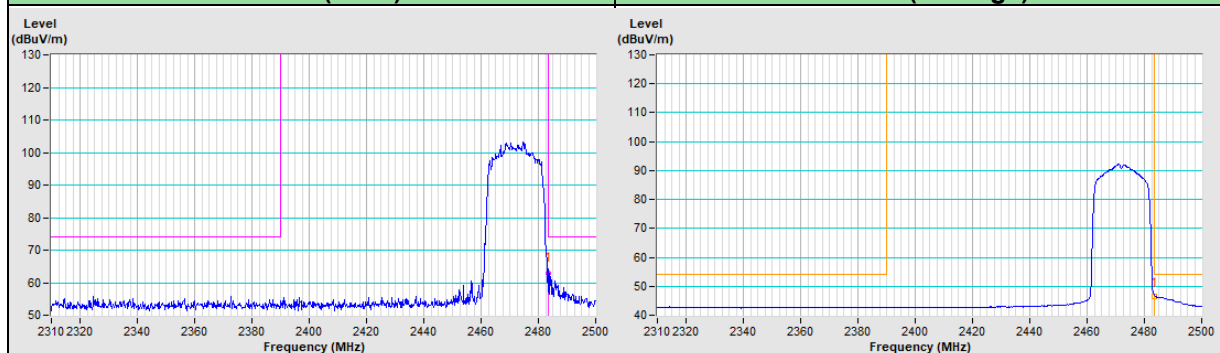

802.11ax (HE40) Channel 3

Horizontal (Peak)

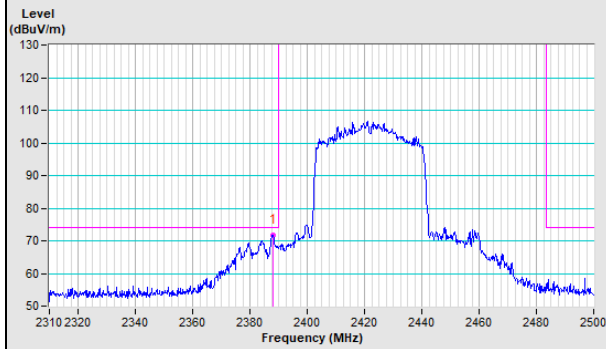

Horizontal (Average)

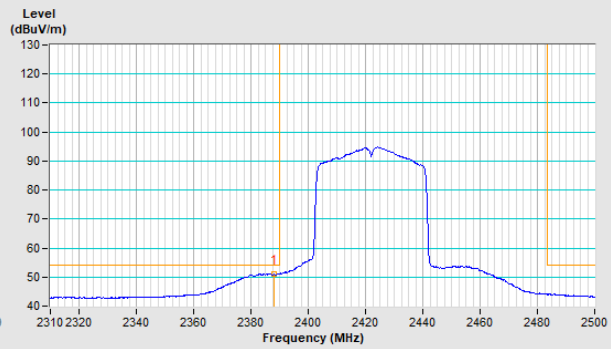

Vertical (Peak)

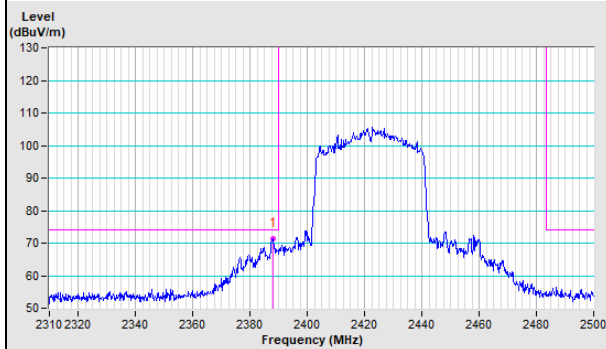

Vertical (Average)

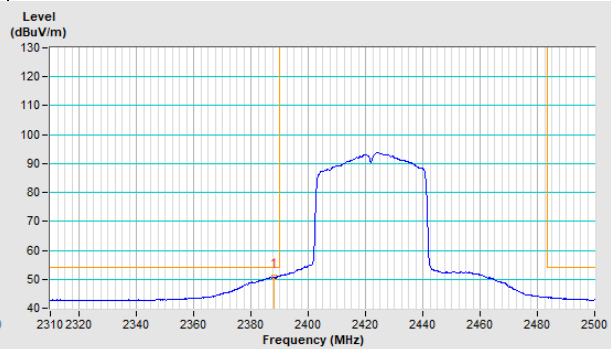

802.11ax (HE40) Channel 9

Horizontal (Peak)

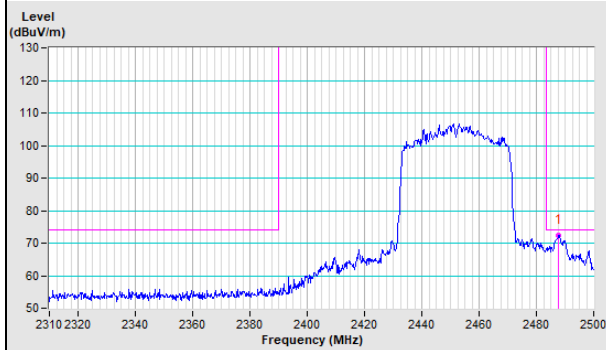

Horizontal (Average)

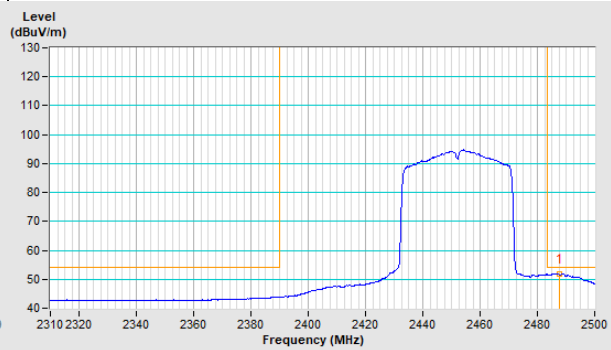

Vertical (Peak)

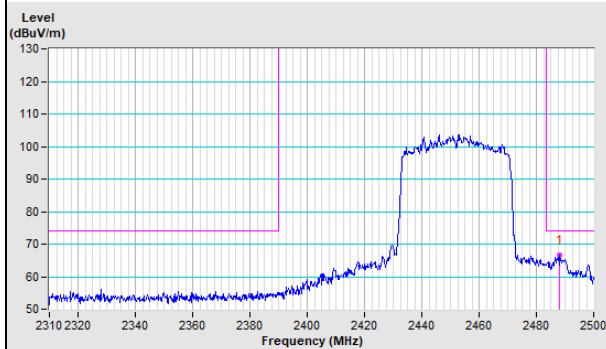

Vertical (Average)

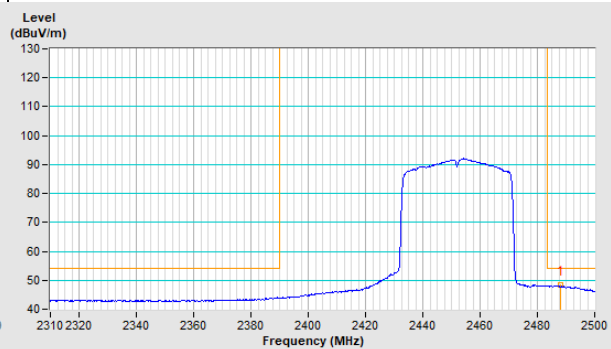

802.11ax (HE40) Channel 10

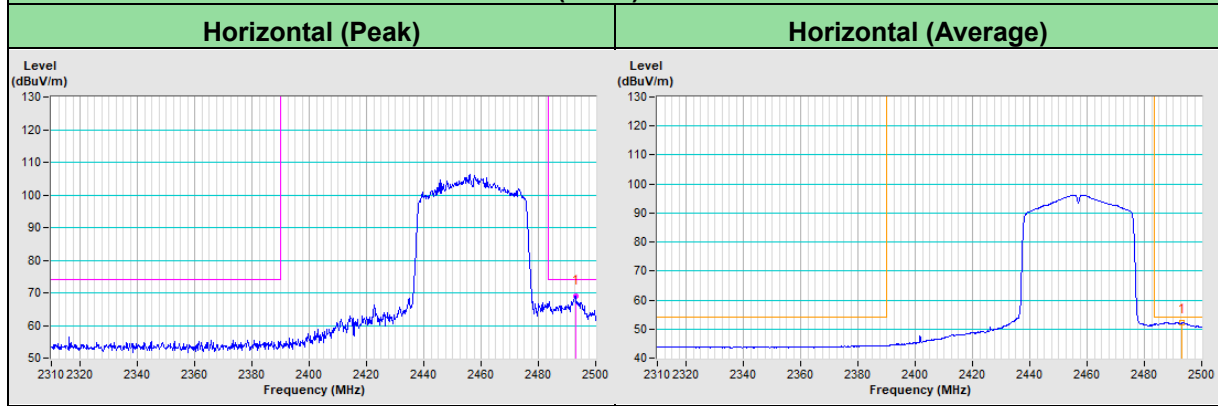

Vertical (Peak)	Vertical (Average)
-----------------	--------------------

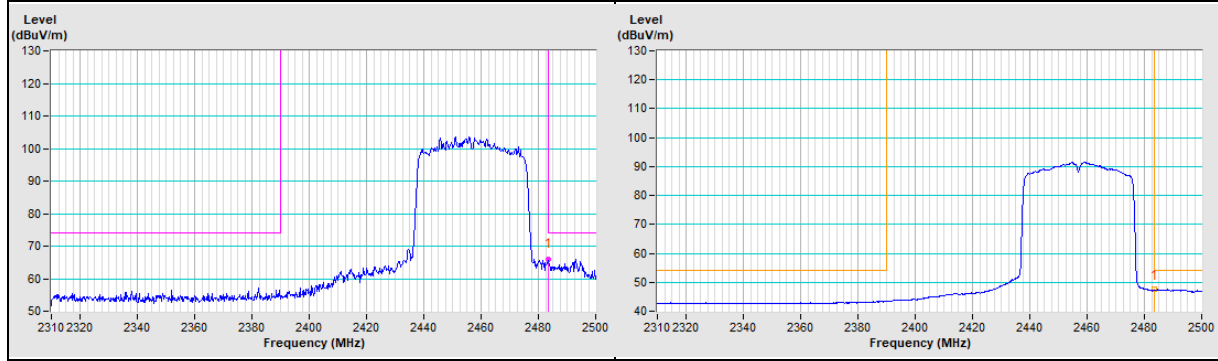

802.11ax (HE40) Channel 11

Horizontal (Peak)	Horizontal (Average)
-------------------	----------------------

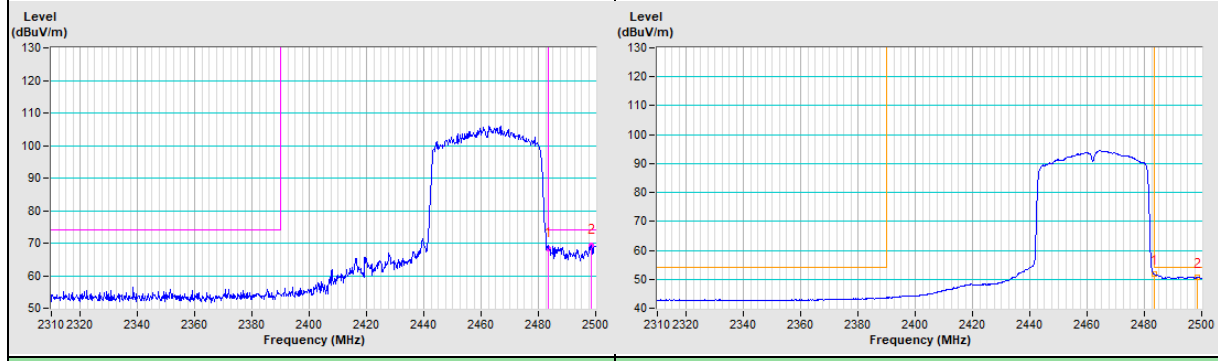

Vertical (Peak)	Vertical (Average)
-----------------	--------------------

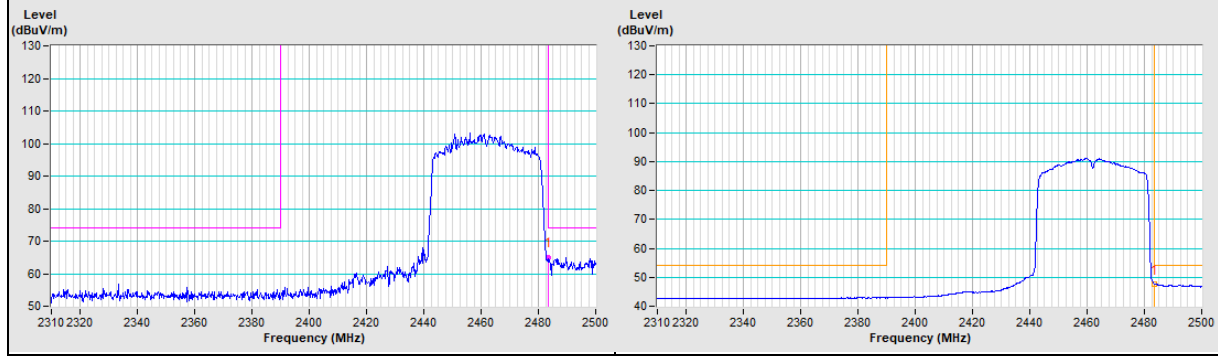

20MHz Preamble 802.11ax (RU26) Channel 1

Horizontal (Peak)	Horizontal (Average)
--------------------------	-----------------------------

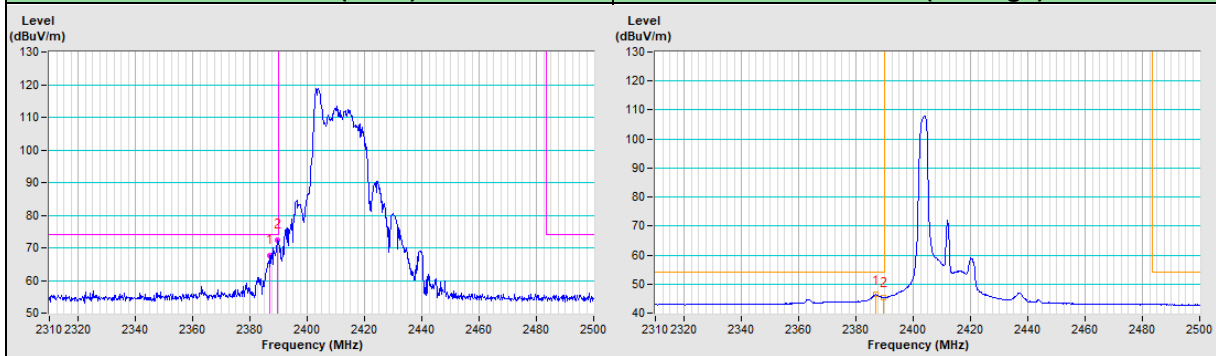

Vertical (Peak)	Vertical (Average)
------------------------	---------------------------

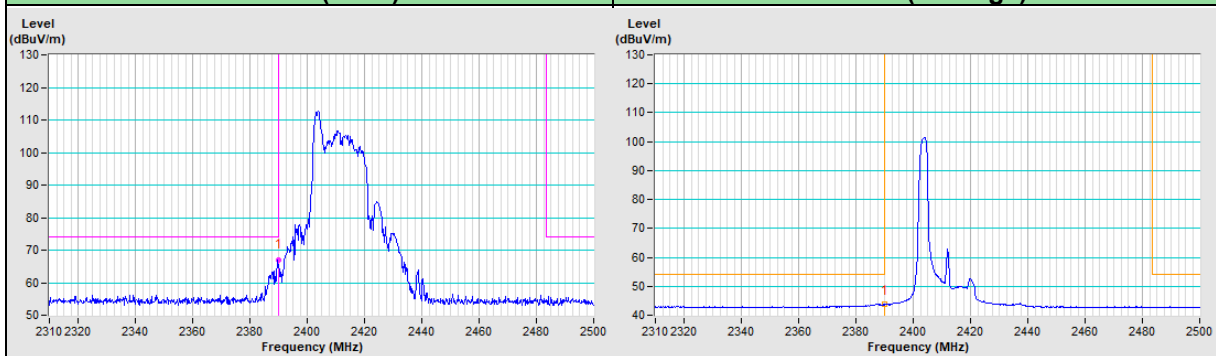

20MHz Preamble 802.11ax (RU26) Channel 11

Horizontal (Peak)	Horizontal (Average)
--------------------------	-----------------------------

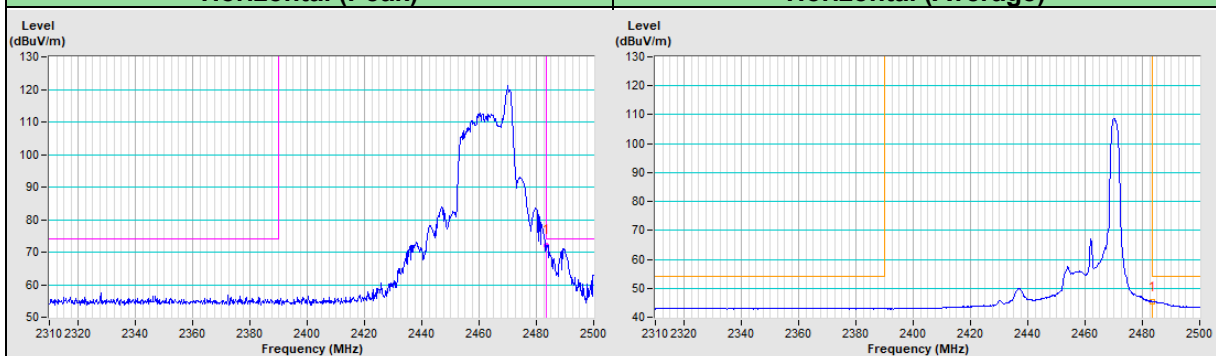

Vertical (Peak)	Vertical (Average)
------------------------	---------------------------

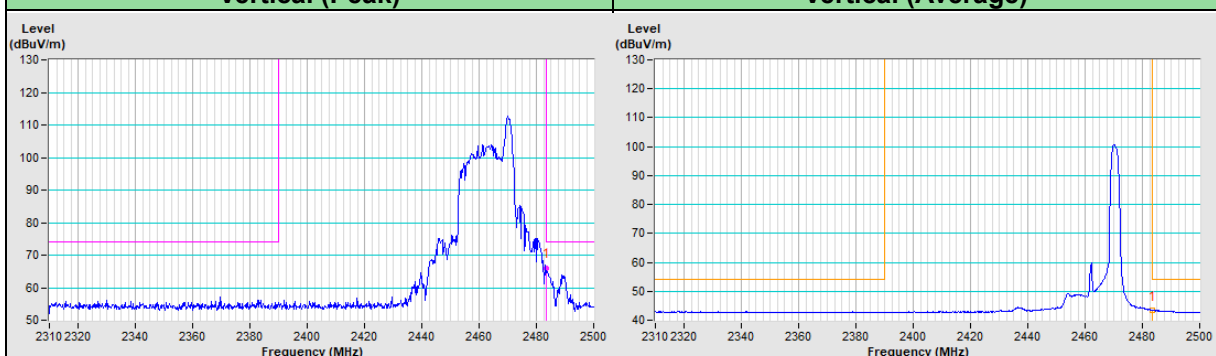

20MHz Preamble 802.11ax (RU26) Channel 12

Horizontal (Peak)

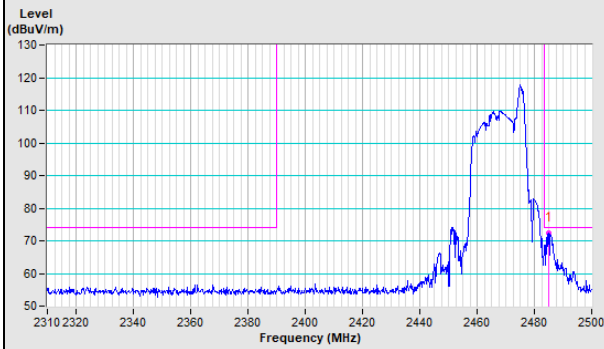

Horizontal (Average)

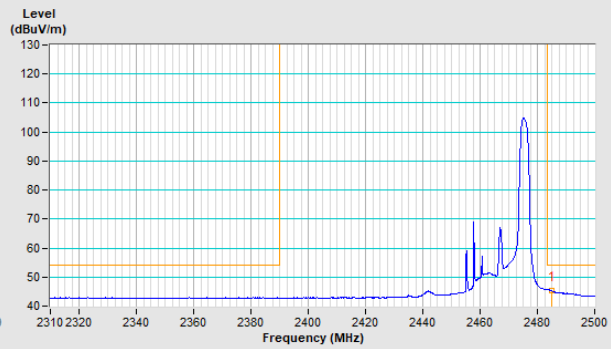

Vertical (Peak)

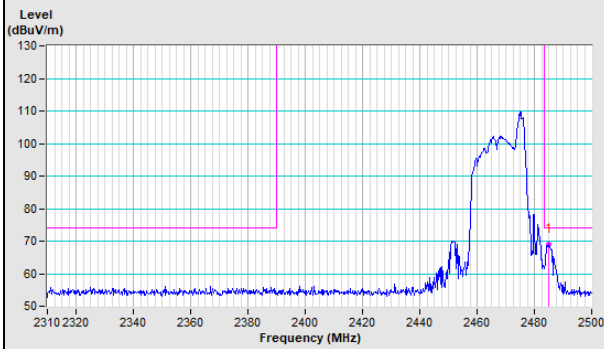

Vertical (Average)

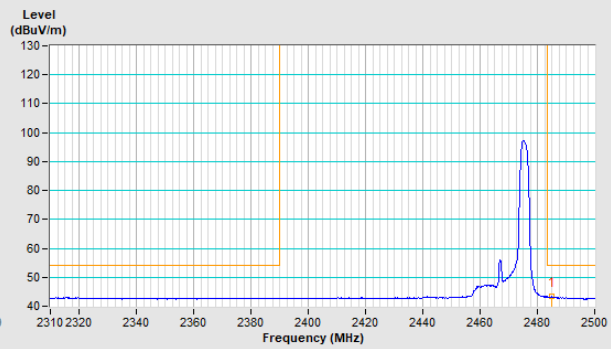

20MHz Preamble 802.11ax (RU26) Channel 13

Horizontal (Peak)

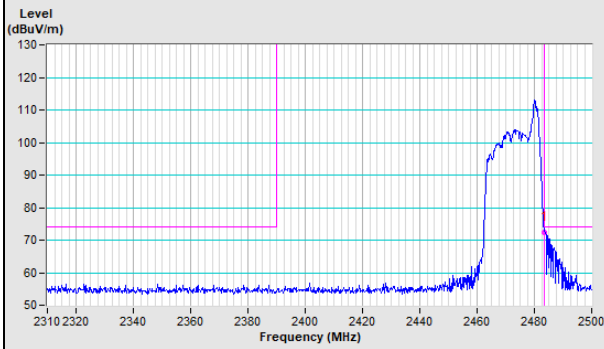

Horizontal (Average)

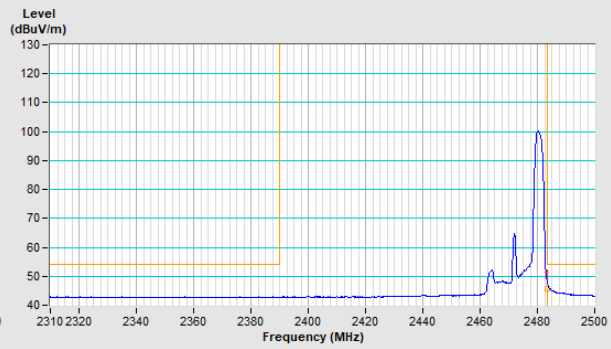

Vertical (Peak)

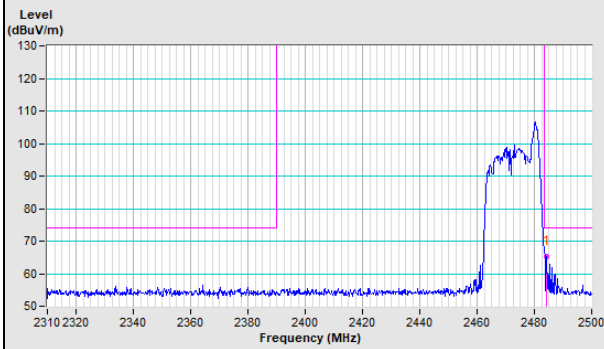

Vertical (Average)

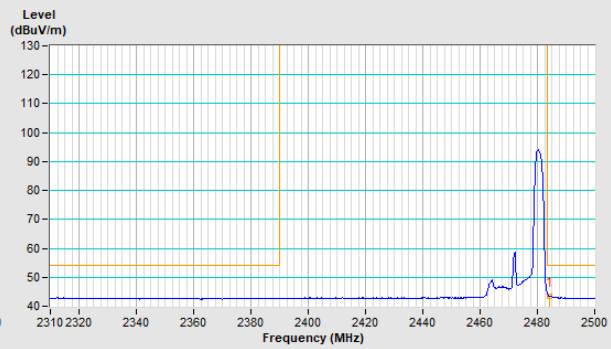

20MHz Preamble 802.11ax (RU52) Channel 1

Horizontal (Peak)	Horizontal (Average)
--------------------------	-----------------------------

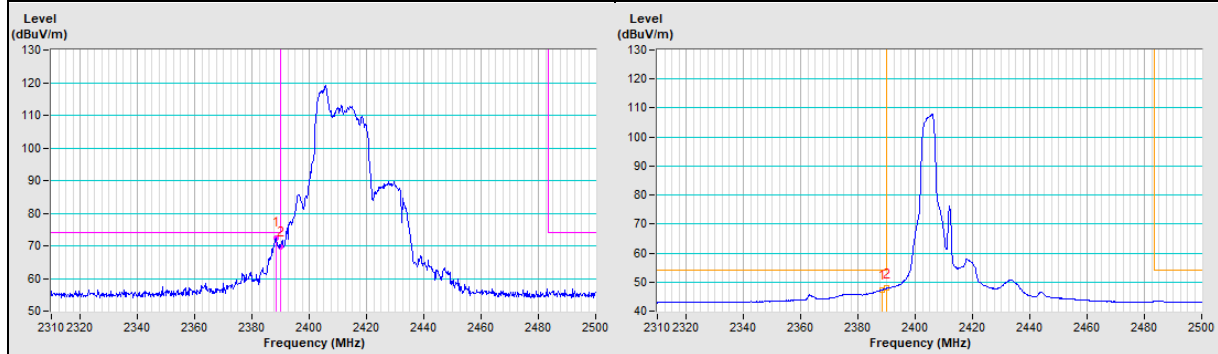

Vertical (Peak)	Vertical (Average)
------------------------	---------------------------

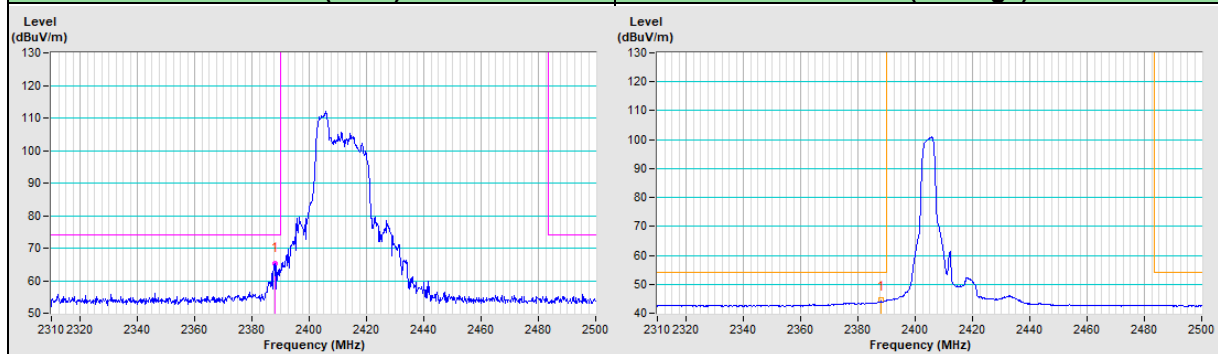

20MHz Preamble 802.11ax (RU52) Channel 11

Horizontal (Peak)	Horizontal (Average)
--------------------------	-----------------------------

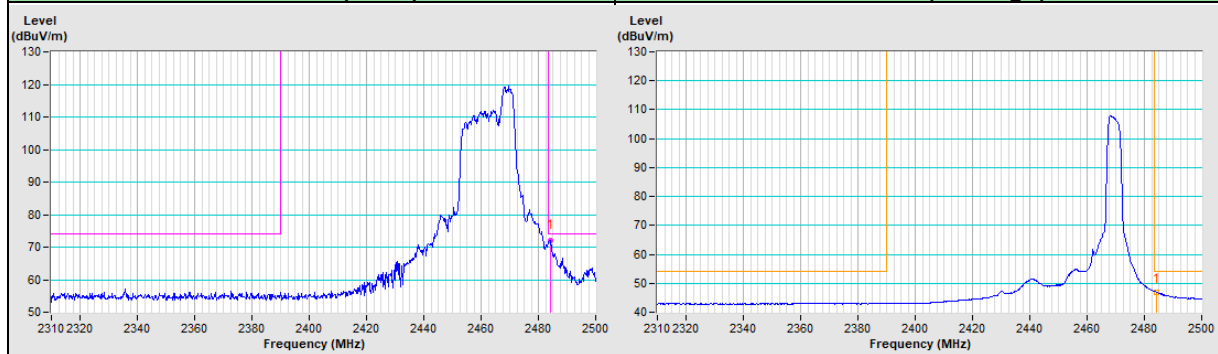

Vertical (Peak)	Vertical (Average)
------------------------	---------------------------

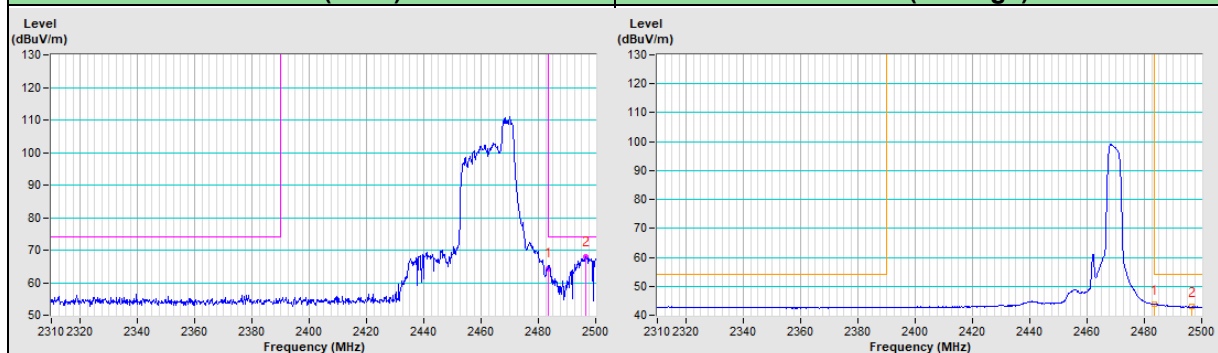

20MHz Preamble 802.11ax (RU52) Channel 12

Horizontal (Peak)

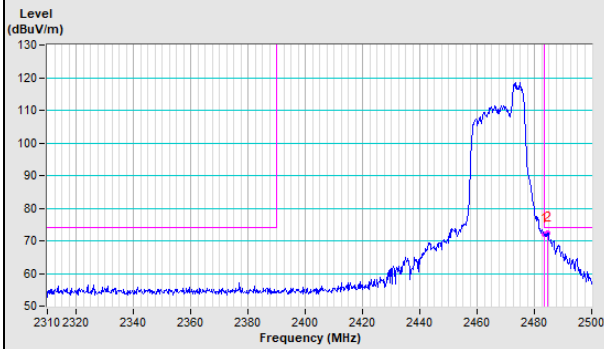

Horizontal (Average)

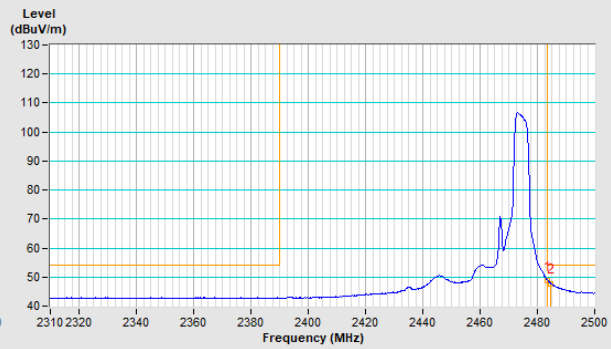

Vertical (Peak)

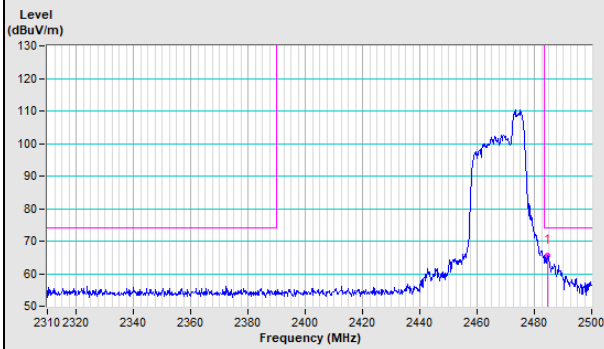

Vertical (Average)

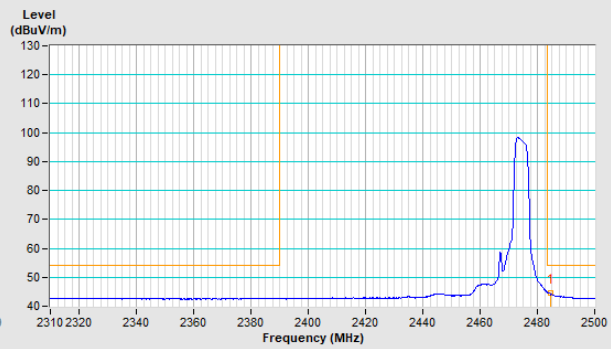

20MHz Preamble 802.11ax (RU52) Channel 13

Horizontal (Peak)

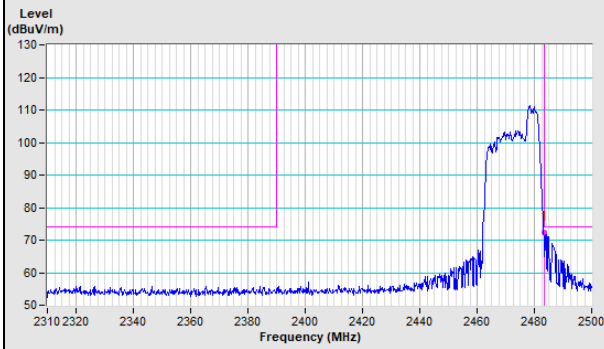

Horizontal (Average)

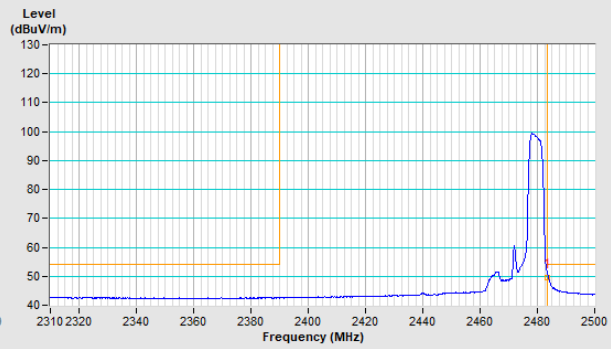

Vertical (Peak)

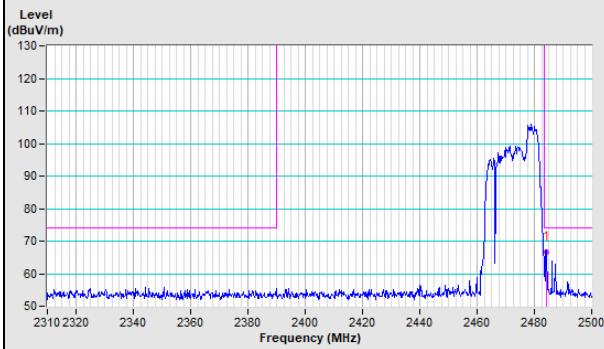

Vertical (Average)

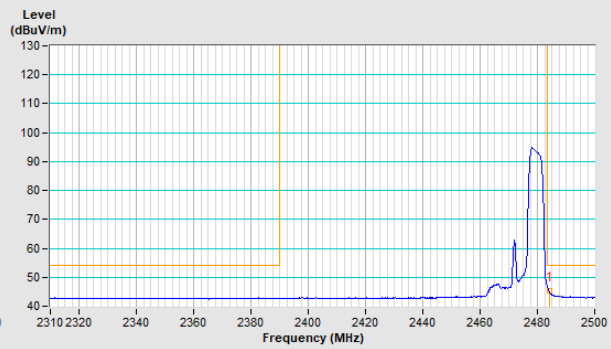

20MHz Preamble 802.11ax (RU106) Channel 1

Horizontal (Peak)	Horizontal (Average)
-------------------	----------------------

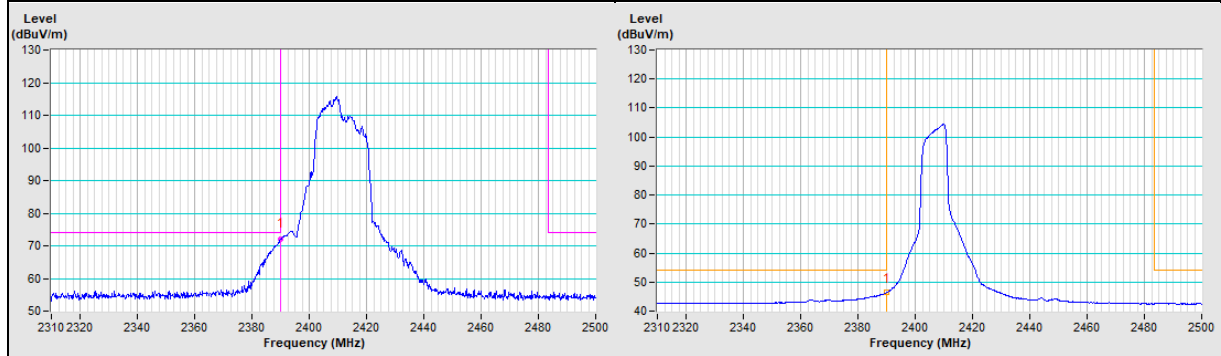

Vertical (Peak)	Vertical (Average)
-----------------	--------------------

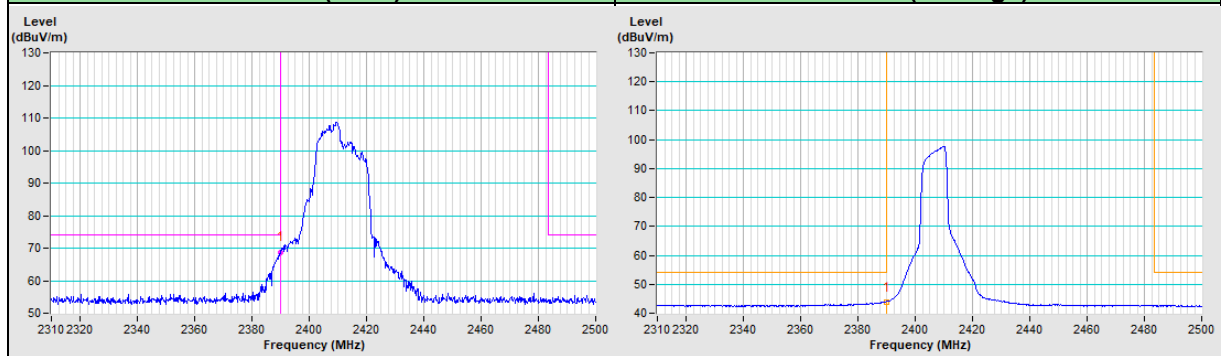

20MHz Preamble 802.11ax (RU106) Channel 11

Horizontal (Peak)	Horizontal (Average)
-------------------	----------------------

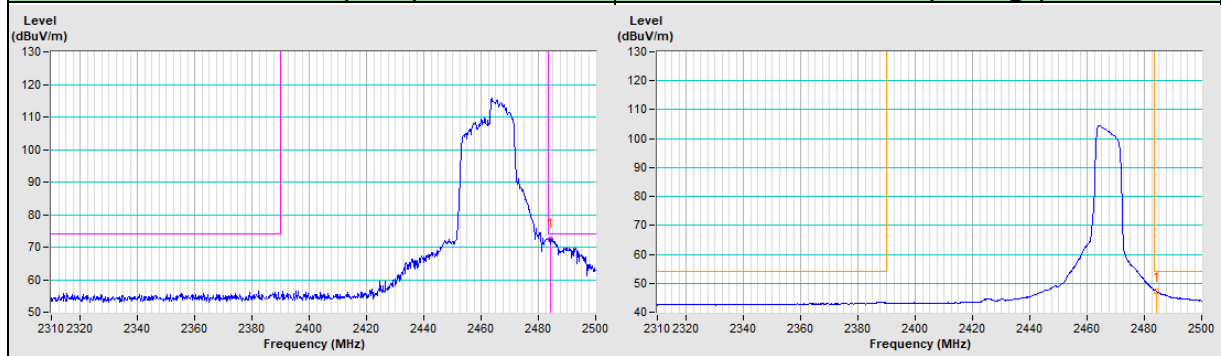

Vertical (Peak)	Vertical (Average)
-----------------	--------------------

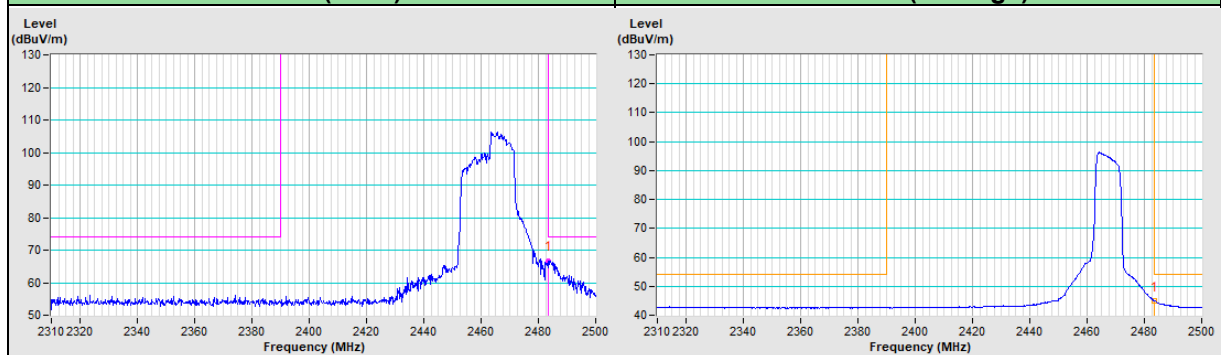

20MHz Preamble 802.11ax (RU106) Channel 12

Horizontal (Peak)

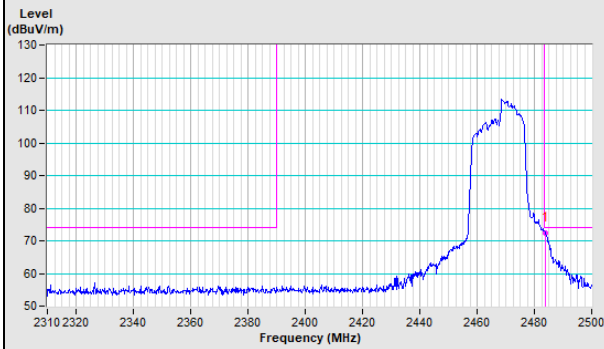

Horizontal (Average)

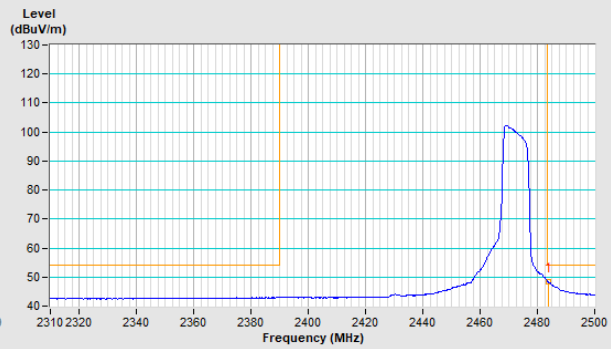

Vertical (Peak)

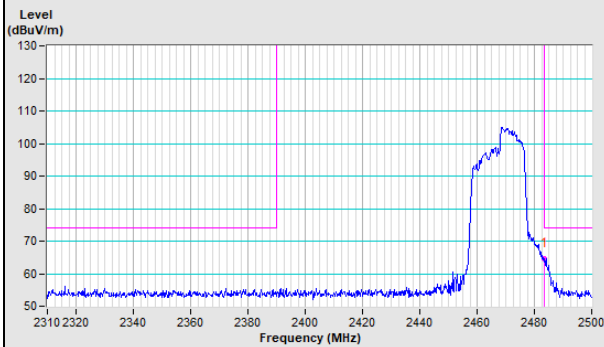

Vertical (Average)

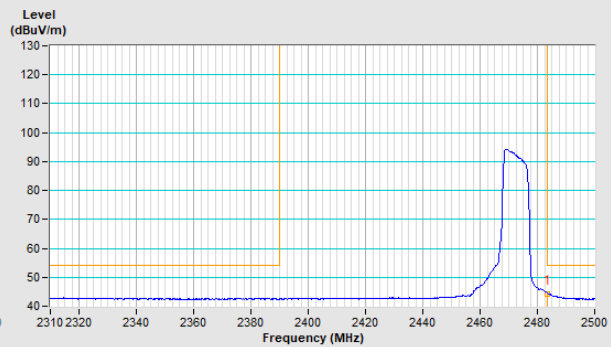

20MHz Preamble 802.11ax (RU106) Channel 13

Horizontal (Peak)

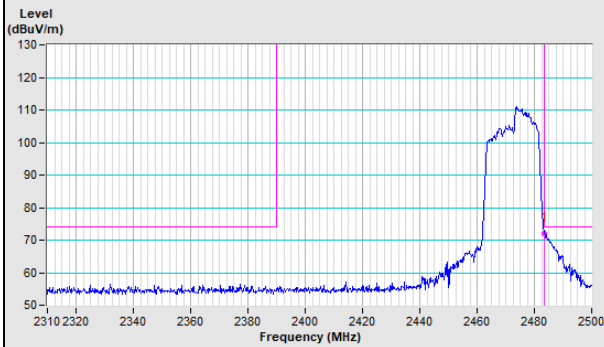

Horizontal (Average)

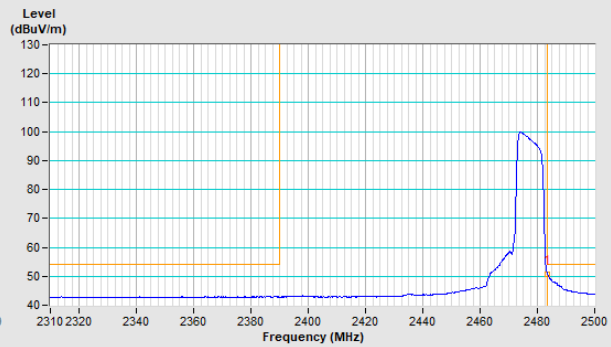

Vertical (Peak)

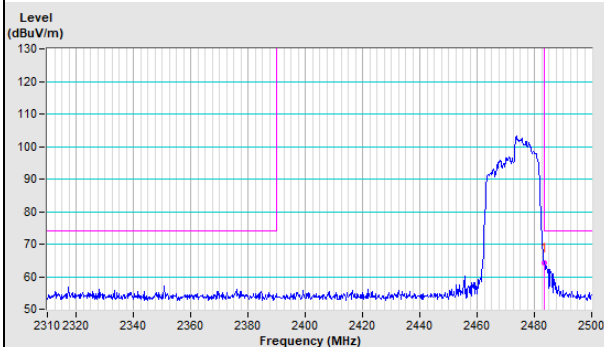

Vertical (Average)

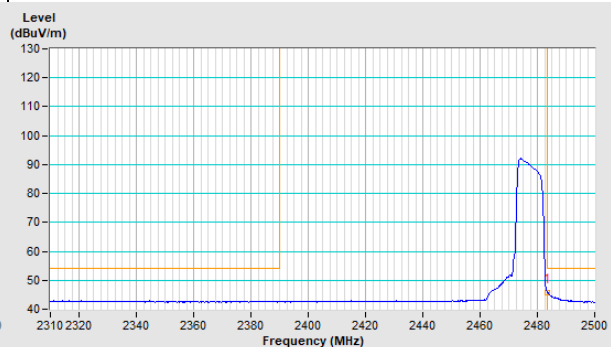

Appendix – Information of the Testing Laboratories

We, Bureau Veritas Consumer Products Services (H.K.) Ltd., Taoyuan Branch, were founded in 1988 to provide our best service in EMC, Radio, Telecom and Safety consultation. Our laboratories are FCC recognized accredited test firms and accredited according to ISO/IEC 17025.

If you have any comments, please feel free to contact us at the following:

Lin Kou EMC/RF Lab

Tel: 886-2-26052180

Fax: 886-2-26051924

Hsin Chu EMC/RF/Telecom Lab

Tel: 886-3-6668565

Fax: 886-3-6668323

Hwa Ya EMC/RF/Safety Lab

Tel: 886-3-3183232

Fax: 886-3-3270892

Email: service.adt@tw.bureauveritas.com

Web Site: www.bureauveritas-adt.com

The address and road map of all our labs can be found in our web site also.

--- END ---