

TEST REPORT

Report No.: BCTC2211166199-4E

Applicant: OKdo Technology Limited

Product Name: Radxa CM3

Model/Type
reference: Radxa CM3

Tested Date: 2022-11-09 to 2022-12-14

Issued Date: 2022-12-15

Shenzhen BCTC Testing Co., Ltd.



SHENZHEN

IC: 29530-RADXACM3

Product Name: Radxa CM3
Trademark: N/A
Model/Type reference: Radxa CM3
Prepared For: OKdo Technology Limited
Address: 5th Floor, 2 Pancras Square, King's Cross, London N1C 4AG, United Kingdom
Manufacturer: OKdo Technology Limited
Address: 5th Floor, 2 Pancras Square, King's Cross, London N1C 4AG, United Kingdom
Prepared By: Shenzhen BCTC Testing Co., Ltd.
Address: 1-2/F., Building B, Pengzhou Industrial Park, No.158, Fuyuan 1st Road, Zhancheng, Fuhai Subdistrict, Bao'an District, Shenzhen, Guangdong, China
Sample Received Date: 2022-11-09
Sample tested Date: 2022-11-09 to 2022-12-14
Issue Date: 2022-12-15
Report No.: BCTC2211166199-4E
Test Standards: RSS-247 Issue 2: February 2017
RSS-Gen Issue 5: Amendment 2 (February 2021)
Test Results: PASS
Remark: This is WIFI-5GHz band radio test report.

Tested by:



Lei Chen/Project Handler

Approved by:



Zero Zhou/Reviewer

The test report is effective only with both signature and specialized stamp. This result(s) shown in this report refer only to the sample(s) tested. Without written approval of Shenzhen BCTC Testing Co., Ltd, this report can't be reproduced except in full. The tested sample(s) and the sample information are provided by the client.



Table Of Content

Test Report Declaration	Page
1. Version	5
2. Test Summary	6
3. Measurement Uncertainty	7
4. Product Information And Test Setup	8
4.1 Product Information	8
4.2 Test Setup Configuration	8
4.3 Support Equipment	9
4.4 Channel List	9
4.5 Test Mode	10
4.6 Table Of Parameters Of Text Software Setting	10
5. Test Facility And Test Instrument Used	11
5.1 Test Facility	11
5.2 Test Instrument Used	11
6. Conducted Emissions	13
6.1 Block Diagram Of Test Setup	13
6.2 Limit	13
6.3 Test procedure	13
6.4 EUT operating Conditions	13
6.5 Test Result	14
7. Radiated Emissions	16
7.1 Block Diagram Of Test Setup	16
7.2 Limit	17
7.3 Test procedure	18
7.4 EUT operating Conditions	19
7.5 Test Result	19
8. Power Spectral Density Test	28
8.1 Block Diagram Of Test Setup	28
8.2 Limit	28
8.3 Test Procedure	29
8.4 EUT operating Conditions	29
8.5 Test Result	30
9. 26dB & 99% Emission Bandwidth	38
9.1 Block Diagram Of Test Setup	38
9.2 Limit	38
9.3 Test procedure	38
9.4 EUT operating Conditions	39
9.5 Test Result	40
10. Maximum Conducted Output Power	55
10.1 Block Diagram Of Test Setup	55
10.2 Limit	55
10.3 Test procedure	55
10.4 EUT operating Conditions	55
10.5 Test Result	56
11. Out Of Band Emissions	64

 BCTC
 3C
 PPR
 检测

11.1	Block Diagram Of Test Setup.....	64
11.2	Limit	64
11.3	Test procedure.....	64
11.4	EUT operating Conditions	64
11.5	Test Result.....	65
12.	Spurious RF Conducted Emissions.....	71
12.1	Block Diagram Of Test Setup.....	71
12.2	Limit	71
12.3	Test procedure.....	71
12.4	Test Result.....	71
13.	Frequency Stability Measurement.....	79
13.1	Block Diagram Of Test Setup.....	79
13.2	Limit	79
13.3	Test procedure.....	79
13.4	Test Result.....	80
14.	Antenna Requirement	83
14.1	Limit	83
14.2	Test Antenna.....	83
15.	EUT Photographs.....	84
16.	EUT Test Setup Photographs.....	85

(Note: N/A Means Not Applicable)

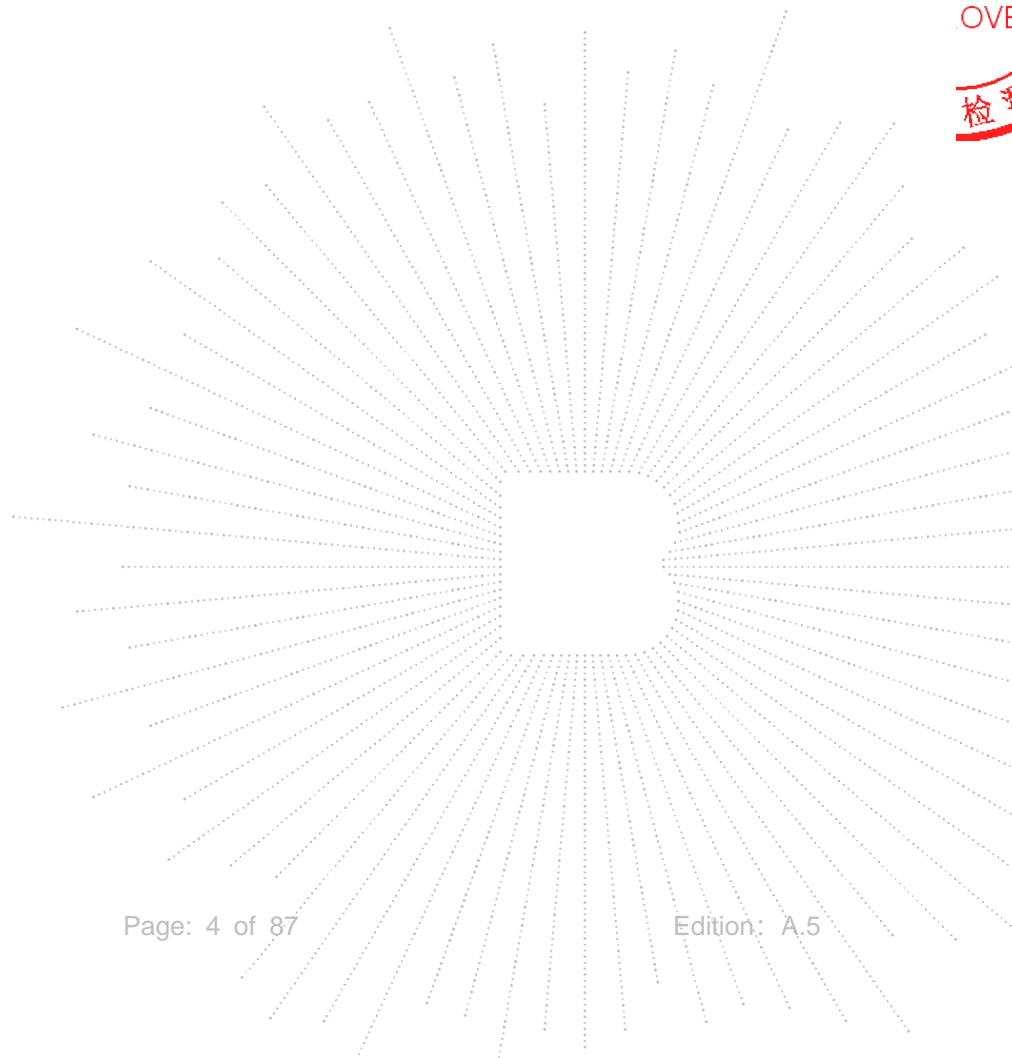

TEC
TC
OVB
檢

1. Version

Report No.	Issue Date	Description	Approved
BCTC2211166199-4E	2022-12-15	Original	Valid

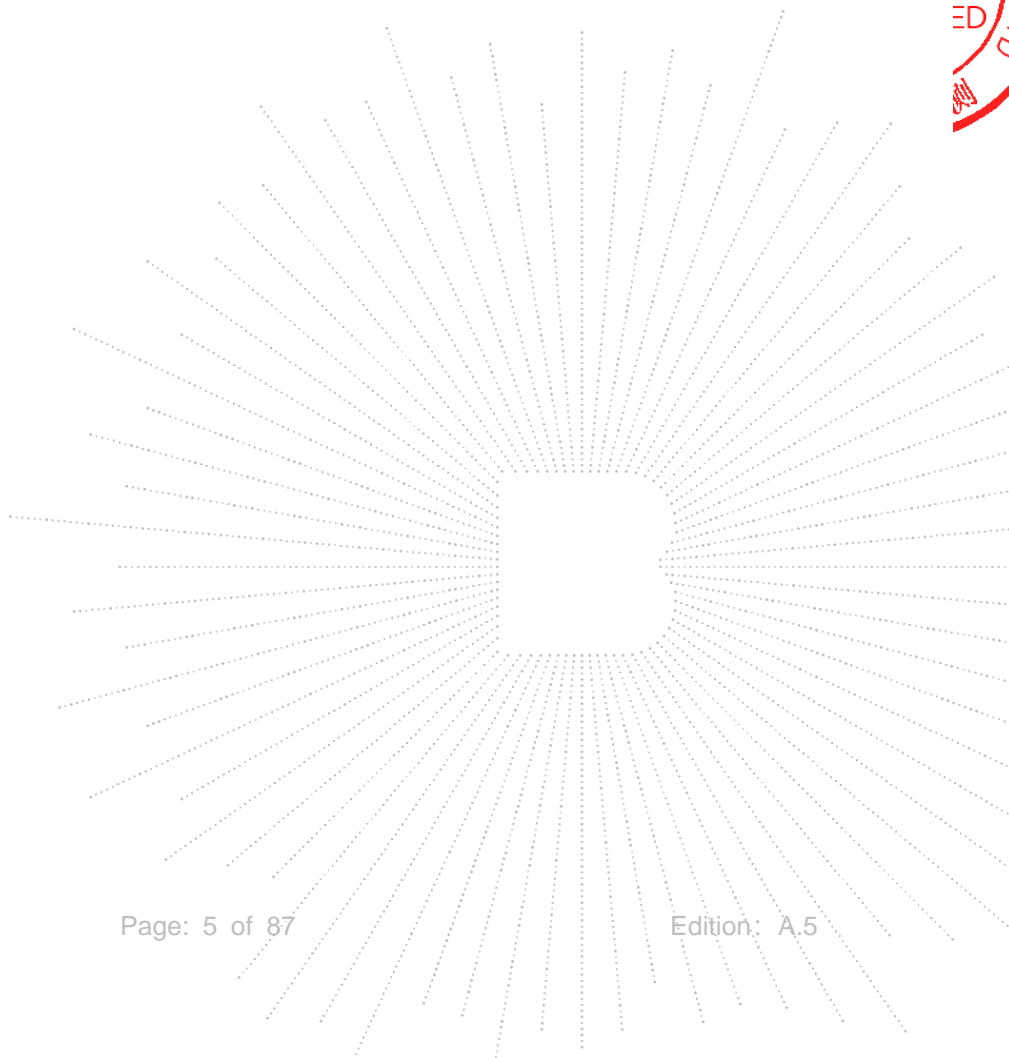

2. Test Summary

The Product has been tested according to the following specifications:

RSS-247 Issue 2: February 2017		
Standard Section	Test Item	Judgment
RSS-GEN 8.8 RSS-247 3.1	Conducted Emission	PASS
RSS-247 6.2.1.2 RSS-247 6.2.2.2 RSS-247 6.2.3.2 RSS-247 6.2.4.2	Spurious Radiated Emissions	PASS
RSS-247 6.2 RSS-GEN 6.7	26 dB and 99% Emission Bandwidth	PASS
RSS-247 6.2 RSS-GEN 6.7	Minimum 6 dB bandwidth	PASS
RSS-247 6.2	Maximum Conducted Output Power	PASS
RSS-247 6.2	Band Edge	PASS
RSS-247 6.2	Power Spectral Density	PASS
RSS-GEN 6.8 RSS-247 3.1	Antenna Requirement	PASS

NOTE:

(1) "N/A" denotes test is not applicable in this Test Report

Outsourcing: The 26G-40G Spurious Radiated Emissions in this test were outsourced to the Shenzhen Academy of Metrology & Quality Inspection

CO., LTD.

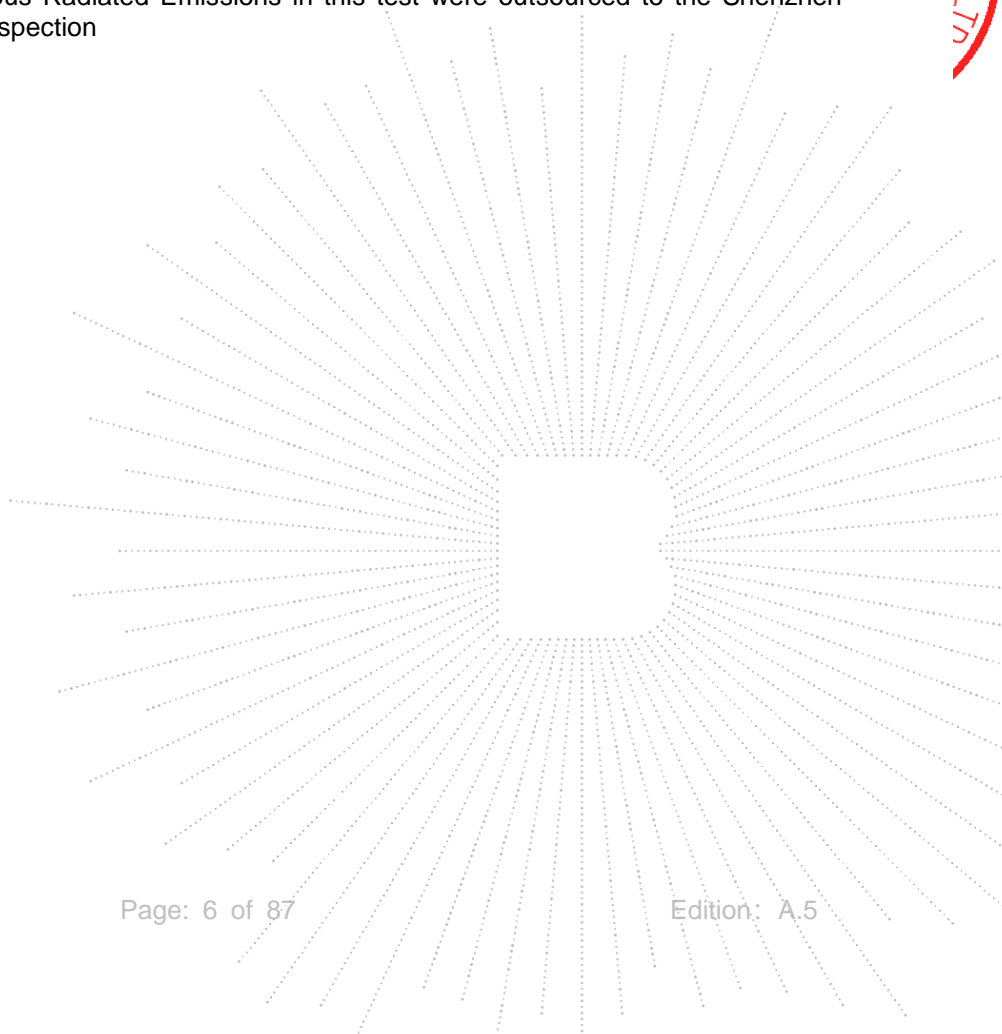

3. Measurement Uncertainty

Where relevant, the following measurement uncertainty levels have been estimated for tests performed on the Product as specified in CISPR 16-4-2. This uncertainty represents an expanded uncertainty expressed at approximately the 95% confidence level using a coverage factor of k=2.

No.	Item	Uncertainty
1	3m chamber Radiated spurious emission(30MHz-1GHz)	U=4.3dB
2	3m chamber Radiated spurious emission(9KHz-30MHz)	U=3.7dB
3	3m chamber Radiated spurious emission(1GHz-18GHz)	U=4.5dB
4	3m chamber Radiated spurious emission(18GHz-40GHz)	U=3.34dB
5	Conducted Emission (150kHz-30MHz)	U=3.20dB
6	Conducted Adjacent channel power	U=1.38dB
7	Conducted output power uncertainty Above 1G	U=1.576dB
8	Conducted output power uncertainty below 1G	U=1.28dB
9	humidity uncertainty	U=5.3%
10	Temperature uncertainty	U=0.59°C

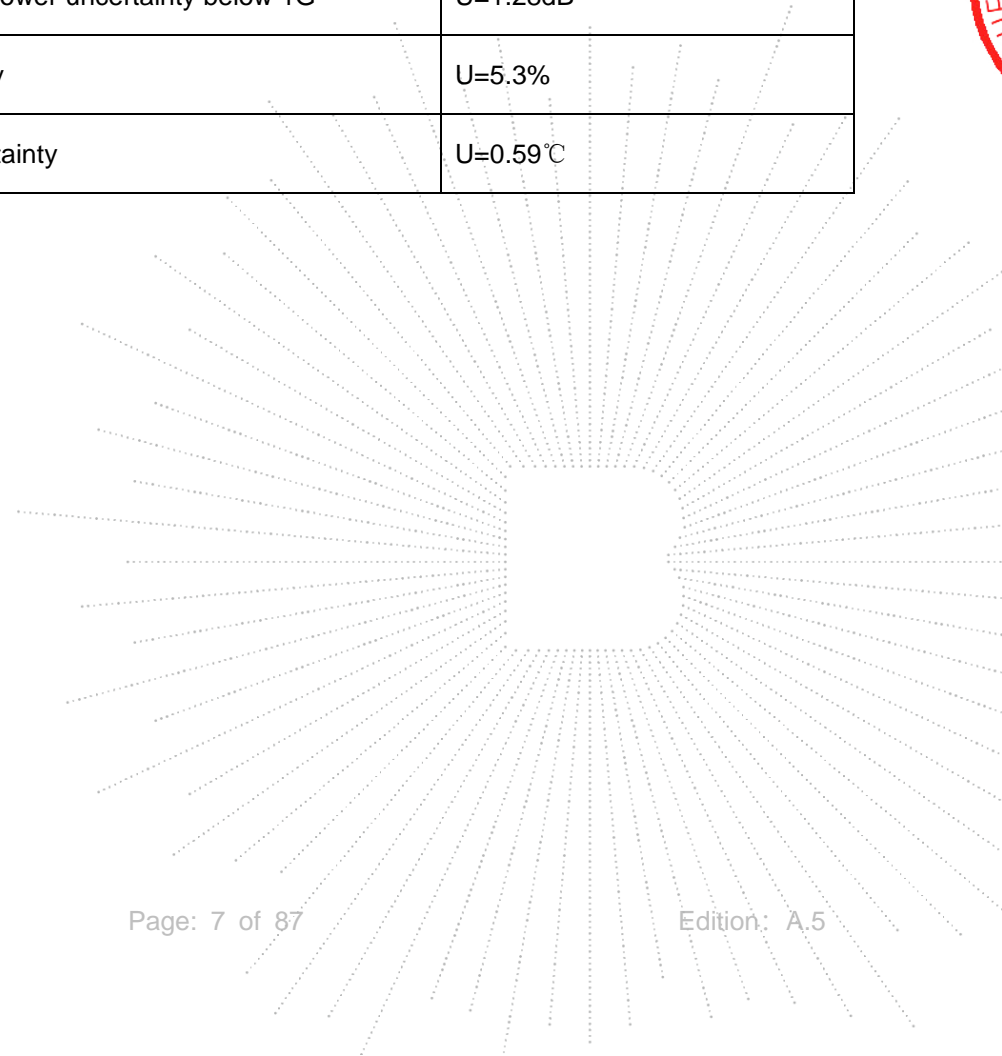
4. Product Information And Test Setup

4.1 Product Information

Model/Type reference:	Radxa CM3
Model differences:	N/A
Hardware Version:	V1.3
Software Version:	4.19
IEEE 802.11 WLAN Mode Supported:	802.11a/n/ac(20MHz channel bandwidth) 802.11n/ac(40MHz channel bandwidth) 802.11ac(80MHz channel bandwidth)
Operation Frequency:	5180-5240MHz for 802.11a/n/ac(HT20); 5190-5230MHz for 802.11n/ac(HT40); 5210MHz for 802.11 ac80;
Data Rate:	802.11a: 6,9,12,18,24,36,48,54Mbps; 802.11n(HT20/HT40):MCS0-MCS15; 802.11ac(VHT20): NSS1, MCS0-MCS8 802.11ac(VHT40/VHT80):NSS1, MCS0-MCS9
Type of Modulation:	OFDM with BPSK/QPSK/16QAM/64QAM/256QAM for 802.11a/n/ac;
Antenna installation:	FPC antenna
Antenna Gain:	4.1dBi
Ratings:	DC 12V

4.2 Test Setup Configuration

See test photographs attached in *EUT TEST SETUP PHOTOGRAPHS* for the actual connections between Product and support equipment.

Conducted Emission:

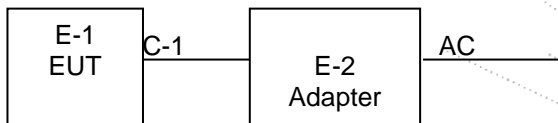

Radiated Spurious Emission

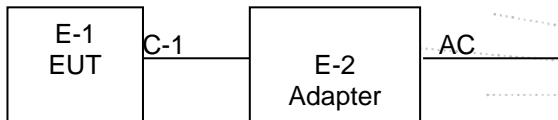

4.3 Support Equipment

No.	Device Type	Brand	Model	Series No.	Note
E-1	Radxa CM3	N/A	Radxa CM3	N/A	EUT
E-2	Adapter	N/A	BCTC001	N/A	Auxiliary

Item	Shielded Type	Ferrite Core	Length	Note
C-1	N/A	N/A	1M	DC cable unshielded

Notes:

1. All the equipment/cables were placed in the worst-case configuration to maximize the emission during the test.
2. Grounding was established in accordance with the manufacturer's requirements and conditions for the intended use.

4.4 Channel List

Frequency and Channel list for 802.11a/n/ac (5180-5240MHz):

802.11a/n/ac(20MHz) Carrier Frequency Channel							
Channel	Frequency (MHz)	Channel	Frequency (MHz)	Channel	Frequency (MHz)	Channel	Frequency (MHz)
36	5180	44	5220	40	5200	48	5240

802.11n/ac(40MHz) Carrier Frequency Channel							
Channel	Frequency (MHz)	Channel	Frequency (MHz)	Channel	Frequency (MHz)	Channel	Frequency (MHz)
38	5190	46	5230	-	-	-	-

802.11ac (80MHz) Carrier Frequency Channel							
Channel	Frequency (MHz)	Channel	Frequency (MHz)	Channel	Frequency (MHz)	Channel	Frequency (MHz)
42	5210	-	-	-	-	-	-

BCTC
 3C
 PPR
 检测

4.5 Test Mode

To investigate the maximum EMI emission characteristics generates from EUT, the test system was pre-scanning tested base on the consideration of following EUT operation mode or test configuration mode which possible have effect on EMI emission level. Each of these EUT operation mode(s) or test configuration mode(s) mentioned above was evaluated respectively.

Pretest Mode	Description
Mode 1	802.11a / n/ ac 20 CH36/ CH40/ CH 48 802.11a /n/ ac 20 CH149/ CH157/ CH 165
Mode 2	802.11n/ ac40 CH38/ CH 46 802.11n/ ac40 CH 151 / CH 159
Mode 3	802.11 ac80 CH 42/CH 155
Mode 4	Link Mode

Conducted Emission	
Final Test Mode	Description
Mode 4	Link Mode

For Radiated Emission	
Final Test Mode	Description
Mode 1	802.11a / n/ ac 20 CH36/ CH40/ CH 48 802.11a /n/ ac 20 CH149/ CH157/ CH 165
Mode 2	802.11n/ ac40 CH38/ CH 46 802.11n/ ac40 CH 151 / CH 159
Mode 3	802.11 ac80 CH 42/CH 155

Note: The measurements are performed at all Bit Rate of Transmitter, the worst data was reported.

4.6 Table Of Parameters Of Text Software Setting

During testing channel & power controlling software provided by the customer was used to control the operating channel as well as the output power level. The RF output power selection is for the setting of RF output power expected by the customer and is going to be fixed on the firmware of the final end product power parameters

Test software Version	CMD		
Parameters	DEF	DEF	DEF

5. Test Facility And Test Instrument Used

5.1 Test Facility

All measurement facilities used to collect the measurement data are located at Shenzhen BCTC Testing Co., Ltd. Address:1-2/F., Building B, Pengzhou Industrial Park, No.158, Fuyuan 1st Road, Zhancheng, Fuhai Subdistrict, Bao'an District, Shenzhen, Guangdong, China. The site and apparatus are constructed in conformance with the requirements of ANSI C63.4 and CISPR 16-1-1 other equivalent standards.

FCC Test Firm Registration Number: 712850

IC Registered No.: 23583

5.2 Test Instrument Used

Conducted Emissions Test					
Equipment	Manufacturer	Model#	Serial#	Last Cal.	Next Cal.
Receiver	R&S	ESR3	102075	May 24, 2022	May 23, 2023
LISN	R&S	ENV216	101375	May 24, 2022	May 23, 2023
Software	Frad	EZ-EMC	EMC-CON 3A1	\	\
Attenuator	\	10dB DC-6GHz	1650	May 24, 2022	May 23, 2023

RF Conducted Test					
Equipment	Manufacturer	Model#	Serial#	Last Cal.	Next Cal.
Power Metter	Keysight	E4419	\	May 24, 2022	May 23, 2023
Power Sensor (AV)	Keysight	E9300A	\	May 24, 2022	May 23, 2023
Signal Analyzer20kHz-26.5GHz	Keysight	N9020A	MY49100060	May 24, 2022	May 23, 2023
Spectrum Analyzer9kHz-40GHz	R&S	FSP40	100363	May 24, 2022	May 23, 2023
Radio frequency control box	MAIWEI	MW100-RFC B	\	\	\
Software	MAIWEI	MTS 8310	\	\	\

Radiated Emissions Test (966 Chamber02)					
Equipment	Manufacturer	Model#	Serial#	Last Cal.	Next Cal.
966 chamber	SKET	966 Room	966	Nov. 02. 2021	Nov. 01.2024
Receiver	R&S	ESR3	102075	May 24, 2022	May 23, 2023
Receiver	R&S	ESRI7	100010	Nov. 08. 2022	Nov. 07.2023
Amplifier	SKET	LNPA-30M01 G-30	SK202108200 4	Nov. 08. 2022	Nov. 07.2023
TRILOG Broadband Antenna	Schwarzbeck	VULB9168	1323	Mar. 06, 2022	Mar. 05, 2024
Loop Antenna(9KHz -30MHz)	Schwarzbeck	FMZB1519B	00014	May 26, 2022	May 25, 2023
Amplifier	SKET	LAPA_01G18 G-45dB	\	May 24, 2022	May 23, 2023
Horn Antenna	Schwarzbeck	BBHA9120D	1541	Jun. 06, 2022	Jun. 05, 2023
Amplifier(18G Hz-40GHz)	MITEQ	TTA1840-35- HG	2034381	May 26, 2022	May 25, 2023
Horn Antenn(18GHz -40GHz)	Schwarzbeck	BBHA9170	00822	Jun. 06, 2022	Jun. 05, 2023
Spectrum Analyzer9kHz- 40GHz	R&S	FSP40	100363	May 24, 2022	May 23, 2023
Software	Frad	EZ-EMC	FA-03A2 RE	\	\

CO.LTD

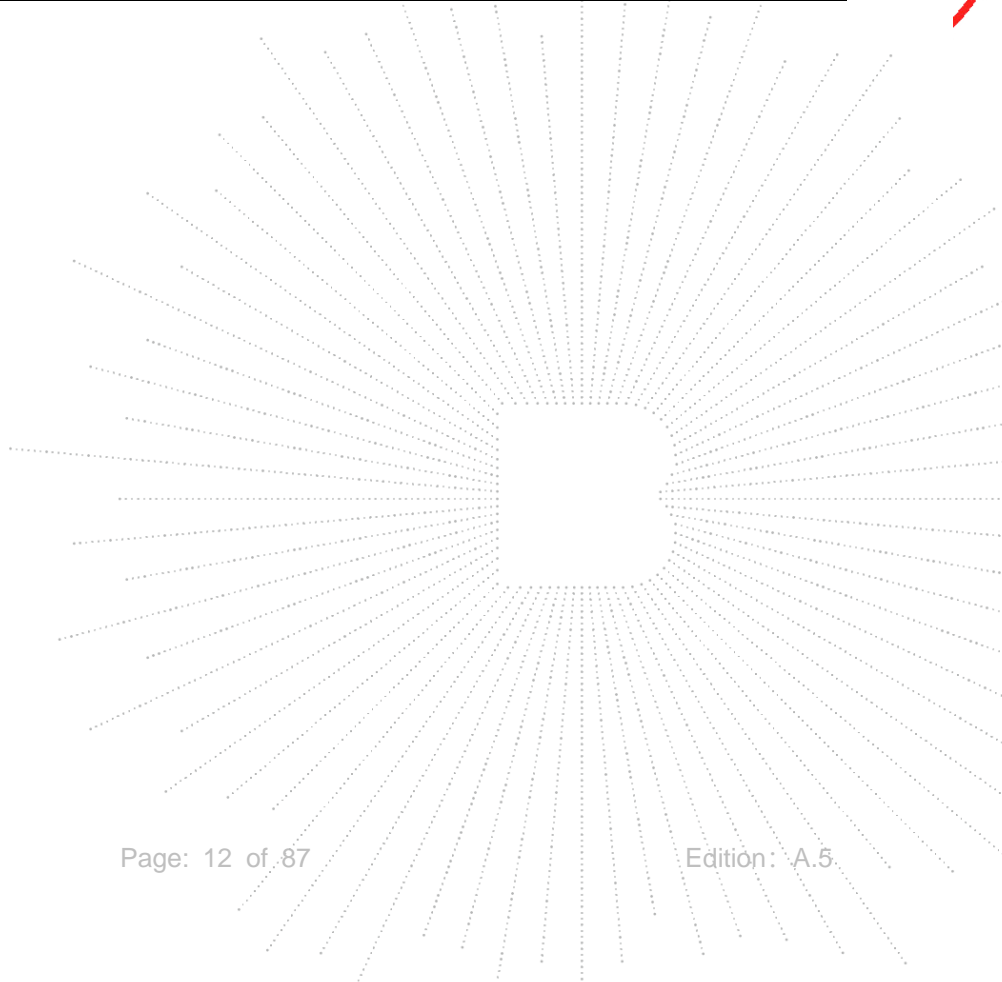

6. Conducted Emissions

6.1 Block Diagram Of Test Setup

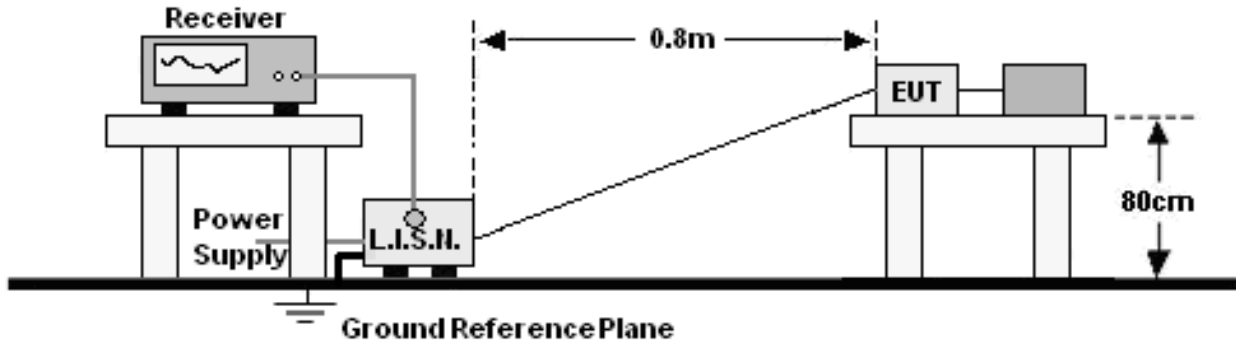

6.2 Limit

Frequency (MHz)	Limit (dBuV)	
	Quas-peak	Average
0.15 -0.5	66 - 56 *	56 - 46 *
0.50 -5.0	56.00	46.00
5.0 -30.0	60.00	50.00

Notes:

1. The tighter limit applies at the band edges.
2. The limit of " * " marked band means the limitation decreases linearly with the logarithm of the frequency in the range.

6.3 Test procedure

Receiver Parameters	Setting
Attenuation	10 dB
Start Frequency	0.15 MHz
Stop Frequency	30 MHz
IF Bandwidth	9 kHz

- a. The EUT was placed 0.8 meters from the horizontal ground plane with EUT being connected to the power mains through a line impedance stabilization network (LISN). All other support equipments powered from additional LISN(s). The LISN provide 50 Ohm/ 50uH of coupling impedance for the measuring instrument.
- b. Interconnecting cables that hang closer than 40 cm to the ground plane shall be folded back and forth in the center forming a bundle 30 to 40 cm long.
- c. I/O cables that are not connected to a peripheral shall be bundled in the center. The end of the cable may be terminated, if required, using the correct terminating impedance. The overall length shall not exceed 1 m.
- d. LISN at least 80 cm from nearest part of EUT chassis.
- e. For the actual test configuration, please refer to the related Item –EUT Test Photos.

6.4 EUT operating Conditions

The EUT was configured for testing in a typical fashion (as a customer would normally use it). The EUT has been programmed to continuously transmit during test. This operating condition was tested and used to collect the included data.

We pretest AC 120V and AC 240V, the worst voltage was AC 120V and the data recording in the report.

6.5 Test Result

Temperature:	26 °C	Relative Humidity:	54%
Pressure:	101KPa	Phase :	L
Test Mode:	Mode 4	Test Voltage :	AC 120V/60Hz

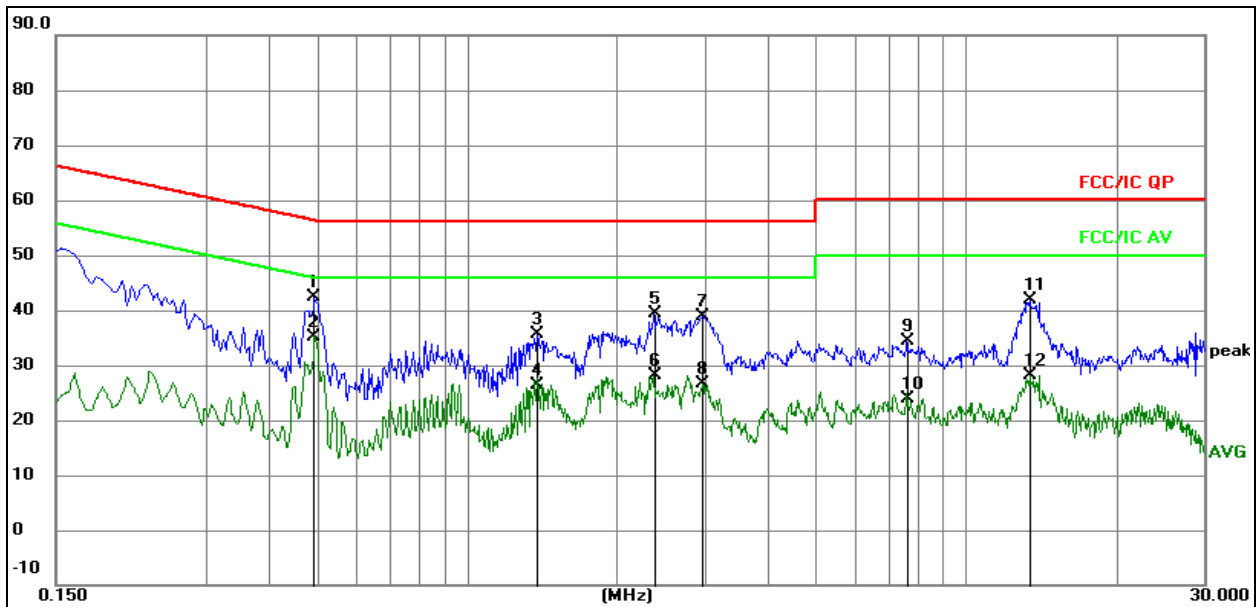

Remark:

1. All readings are Quasi-Peak and Average values.
2. Factor = Insertion Loss + Cable Loss.
3. Measurement = Reading Level + Correct Factor
4. Over = Measurement - Limit

No.	Mk.	Freq. MHz	Reading Level	Correct Factor dB	Measure- ment dBuV	Limit dBuV	Over dB	Detector
1		0.4941	22.62	19.72	42.34	56.10	-13.76	QP
2	*	0.4941	15.53	19.72	35.25	46.10	-10.85	AVG
3		1.3810	15.80	19.81	35.61	56.00	-20.39	QP
4		1.3810	6.68	19.81	26.49	46.00	-19.51	AVG
5		2.3710	19.35	19.92	39.27	56.00	-16.73	QP
6		2.3710	8.10	19.92	28.02	46.00	-17.98	AVG
7		2.9619	18.79	19.99	38.78	56.00	-17.22	QP
8		2.9619	6.75	19.99	26.74	46.00	-19.26	AVG
9		7.6060	14.24	20.20	34.44	60.00	-25.56	QP
10		7.6060	3.62	20.20	23.82	50.00	-26.18	AVG
11		13.4080	21.59	20.28	41.87	60.00	-18.13	QP
12		13.4080	7.85	20.28	28.13	50.00	-21.87	AVG

Temperature:	26 °C	Relative Humidity:	54%
Pressure:	101KPa	Phase :	N
Test Mode:	Mode 4	Test Voltage :	AC 120V/60Hz

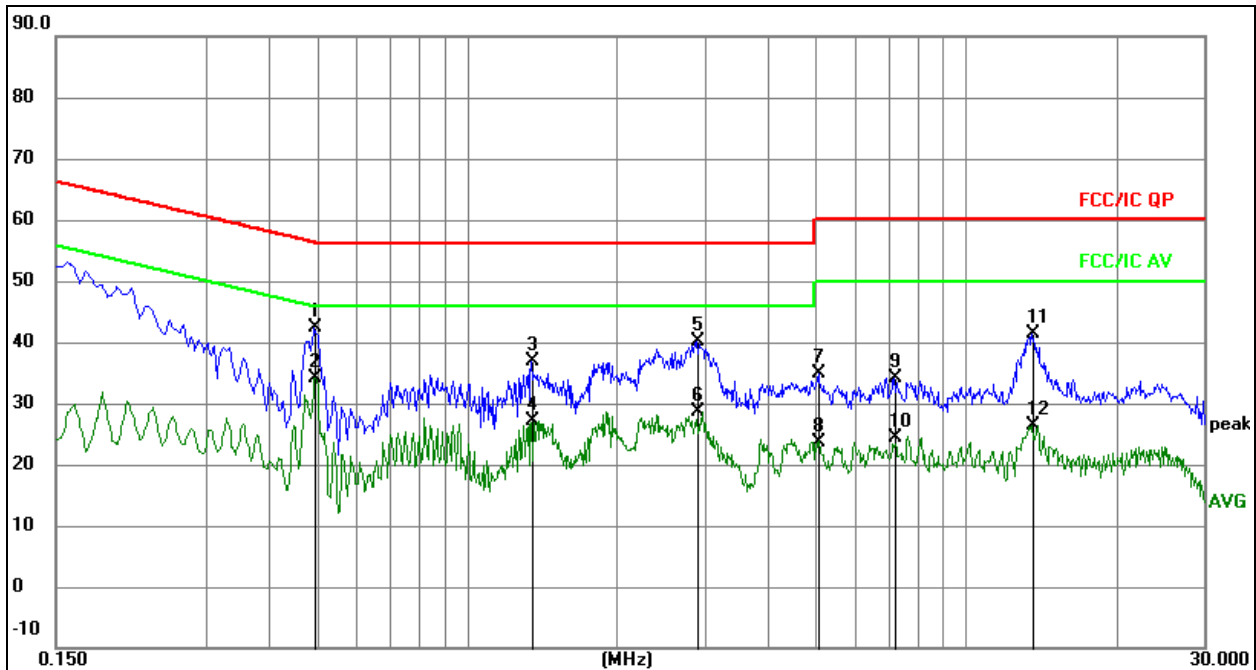
Remark:

1. All readings are Quasi-Peak and Average values.
2. Factor = Insertion Loss + Cable Loss.
3. Measurement = Reading Level + Correct Factor
4. Over = Measurement - Limit

No.	Mk.	Freq. MHz	Reading Level	Correct Factor dB	Measure- ment dBuV	Limit dBuV	Over dB	Detector
1		0.4965	22.73	19.72	42.45	56.06	-13.61	QP
2	*	0.4965	14.29	19.72	34.01	46.06	-12.05	AVG
3		1.3470	17.08	19.80	36.88	56.00	-19.12	QP
4		1.3470	7.22	19.80	27.02	46.00	-18.98	AVG
5		2.8950	20.20	19.98	40.18	56.00	-15.82	QP
6		2.8950	8.76	19.98	28.74	46.00	-17.26	AVG
7		5.0685	14.75	20.13	34.88	60.00	-25.12	QP
8		5.0685	3.38	20.13	23.51	50.00	-26.49	AVG
9		7.2015	13.97	20.19	34.16	60.00	-25.84	QP
10		7.2015	4.16	20.19	24.35	50.00	-25.65	AVG
11		13.5735	21.04	20.28	41.32	60.00	-18.68	QP
12		13.5735	6.06	20.28	26.34	50.00	-23.66	AVG

7. Radiated Emissions

7.1 Block Diagram Of Test Setup

(A) Radiated Emission Test-Up Frequency Below 30MHz

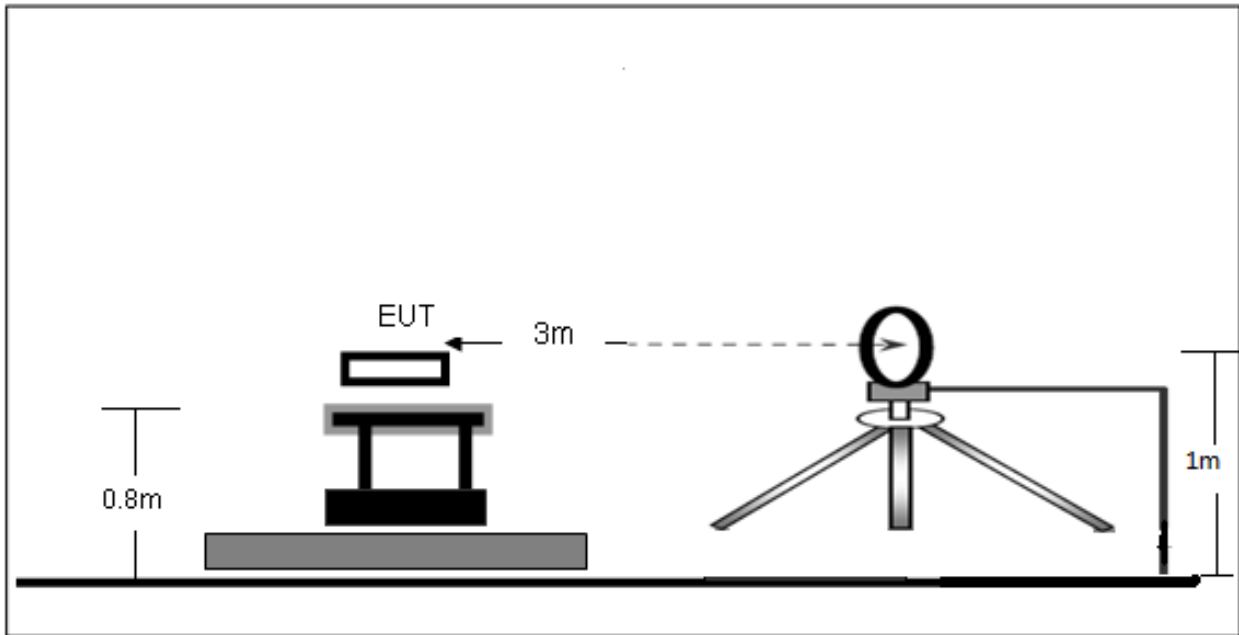

(B) Radiated Emission Test-Up Frequency 30MHz~1GHz

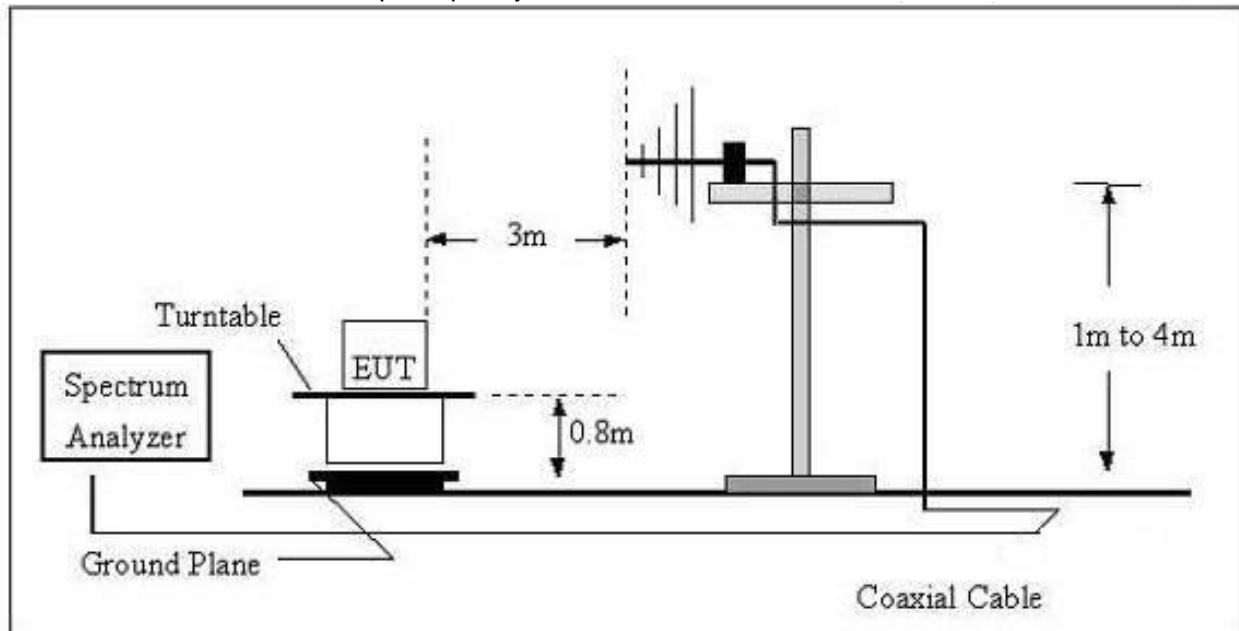

(C) Radiated Emission Test-Up Frequency Above 1GHz

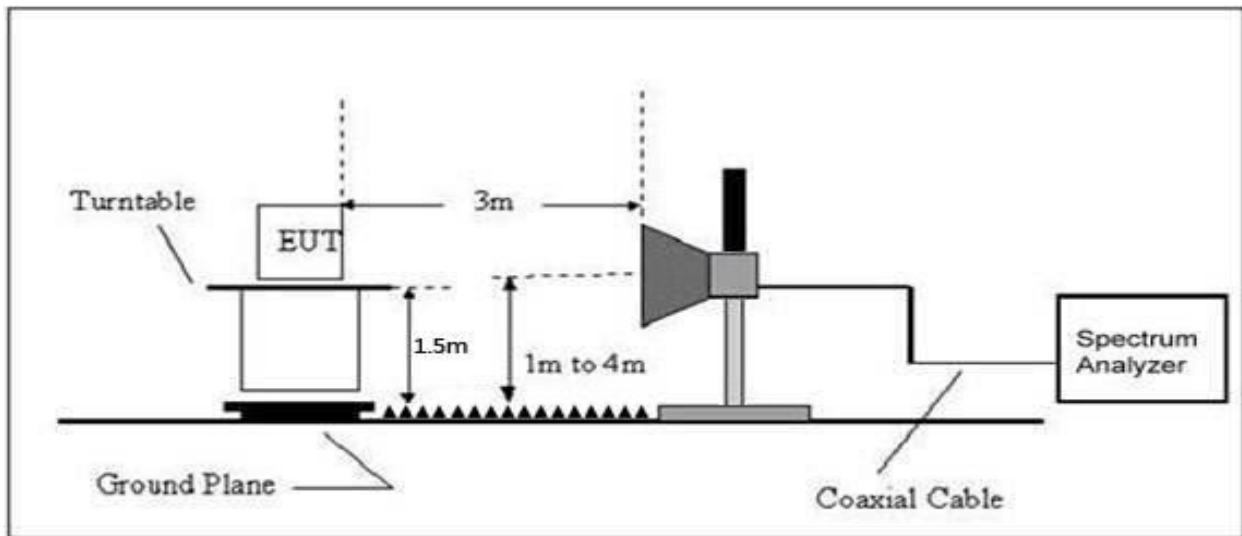

7.2 Limit

According to RSS-247: radiated emissions which fall in the restricted bands, must also comply with the radiated emission limits specified in RSS-GEN 8.9. and RSS-GEN 8.10 Restricted bands

Table 7 – Restricted frequency bands*

MHz	MHz	GHz
0.090 - 0.110	149.9 - 150.05	9.0 - 9.2
0.495 - 0.505	156.52475 - 156.52525	9.3 - 9.5
2.1735 - 2.1905	156.7 - 156.9	10.6 - 12.7
3.020 - 3.026	162.0125 - 167.17	13.25 - 13.4
4.125 - 4.128	167.72 - 173.2	14.47 - 14.5
4.17725 - 4.17775	240 - 285	15.35 - 16.2
4.20725 - 4.20775	322 - 335.4	17.7 - 21.4
5.677 - 5.683	399.9 - 410	22.01 - 23.12
6.215 - 6.218	608 - 614	23.6 - 24.0
6.26775 - 6.26825	960 - 1427	31.2 - 31.8
6.31175 - 6.31225	1435 - 1626.5	36.43 - 36.5
8.291 - 8.294	1645.5 - 1646.5	Above 38.6
8.362 - 8.366	1660 - 1710	
8.37625 - 8.38675	1718.8 - 1722.2	
8.41425 - 8.41475	2200 - 2300	
12.29 - 12.293	2310 - 2390	
12.51975 - 12.52025	2483.5 - 2500	
12.57675 - 12.57725	2655 - 2900	
13.36 - 13.41	3260 - 3267	
16.42 - 16.423	3332 - 3339	
16.69475 - 16.69525	3345.8 - 3358	
16.80425 - 16.80475	3500 - 4400	
25.5 - 25.67	4500 - 5150	
37.5 - 38.25	5350 - 5460	
73 - 74.6	7250 - 7750	
74.8 - 75.2	8025 - 8500	
108 - 138	--	

* Certain frequency bands listed in table 7 and in bands above 38.6 GHz are designated for licence-exempt applications. These frequency bands and the requirements that apply to related devices are set out in the 200 and 300 series of RSSs.



Table 5 – General field strength limits at frequencies above 30 MHz

Frequency (MHz)	Field strength ($\mu\text{V/m}$ at 3 m)
30 – 88	100
88 – 216	150
216 – 960	200
Above 960	500

Table 6 – General field strength limits at frequencies below 30 MHz

Frequency	Magnetic field strength (H-Field) ($\mu\text{A/m}$)	Measurement distance (m)
9 - 490 kHz ¹	$6.37/F$ (F in kHz)	300
490 - 1705 kHz	$63.7/F$ (F in kHz)	30
1.705 - 30 MHz	0.08	30

Note 1: The emission limits for the ranges 9-90 kHz and 110-490 kHz are based on measurements employing a linear average detector.

7.3 Test procedure

The test site semi-anechoic chamber has met the requirement of NSA tolerance 4 dB according to the standards: ANSI C63.10-2013. The test distance is 3m. The setup is according to the requirements in Section 13.1.4.1 of ANSI C63.10-2013 and CAN/CSA-CEI/IEC CISPR 22.

This test is required for any spurious emission that falls in a Restricted Band, as defined in Section 15.205.

It must be performed with the highest gain of each type of antenna proposed for use with the EUT. Use the following spectrum analyzer settings:

Spectrum Parameter	Setting
Attenuation	Auto
Start Frequency	1000 MHz
Stop Frequency	10th carrier harmonic
RB / VB (emission in restricted band)	1 MHz / 1 MHz for Peak, 1 MHz / 10Hz for Average

Receiver Parameter	Setting
Attenuation	Auto
Start ~ Stop Frequency	9kHz~150kHz / RB 200Hz for QP
Start ~ Stop Frequency	150kHz~30MHz / RB 9kHz for QP
Start ~ Stop Frequency	30MHz~1000MHz / RB 120kHz for QP

a. The measuring distance of at 3 m shall be used for measurements at frequency up to 1GHz. For frequencies above 1GHz, any suitable measuring distance may be used.

- b. The EUT was placed on the top of a rotating table 0.8 m for below 1GHz and 1.5m for above 1GHz the ground at a 3 meter. The table was rotated 360 degrees to determine the position of the highest radiation.
- c. The height of the equipment or of the substitution antenna shall be 0.8 m for below 1GHz and 1.5m for above 1GHz; the height of the test antenna shall vary between 1 m to 4 m. Both horizontal and vertical polarizations of the antenna are set to make the measurement.
- d. The initial step in collecting conducted emission data is a spectrum analyzer peak detector mode pre-scanning the measurement frequency range. Significant peaks are then marked and then Quasi Peak detector mode re-measured
- e. If the Peak Mode measured value compliance with and lower than Quasi Peak Mode Limit, the EUT shall be deemed to meet QP Limits and then no additional QP Mode measurement performed.
- f. For the actual test configuration, please refer to the related Item –EUT Test Photos.

Note:

Both horizontal and vertical antenna polarities were tested and performed pretest to three orthogonal axis. The worst case emissions were reported

During the radiated emission test, the Spectrum Analyzer was set with the following configurations:

Frequency Band (MHz)	Function	Resolution bandwidth	Video Bandwidth
30 to 1000	QP	120 kHz	300 kHz
Above 1000	Peak	1 MHz	1 MHz
	Average	1 MHz	10 Hz

Note: for the frequency ranges below 30 MHz, a narrower RBW is used for these ranges but the measured value should add a RBW correction factor (RBWCF) where $RBWCF [dB] = 10 \cdot \lg(100 [kHz]/\text{narrower RBW} [kHz])$. , the narrower RBW is 1 kHz and RBWCF is 20 dB for the frequency 9 kHz to 150 kHz, and the narrower RBW is 10 kHz and RBWCF is 10 dB for the frequency 150 kHz to 30 MHz.

7.4 EUT operating Conditions

The EUT was configured for testing in a typical fashion (as a customer would normally use it). The EUT has been programmed to continuously transmit during test. This operating condition was tested and used to collect the included data.

7.5 Test Result

Below 30MHz

Temperature:	26 °C	Relative Humidity:	54%
Pressure:	101 kPa	Test Voltage :	AC 120V/60Hz
Test Mode:	Mode 4	Polarization:	--

Freq. (MHz)	Reading (dBuV/m)	Limit (dBuV/m)	Margin (dB)	State P/F
--	--	--	--	PASS
--	--	--	--	PASS

Note:

The amplitude of spurious emissions which are attenuated by more than 20dB below the permissible value has no need to be reported.

Distance extrapolation factor = $40 \log(\text{specific distance}/\text{test distance})(dB)$;

Limit line = specific limits(dBuv) + distance extrapolation factor.



Between 30MHz – 1GHz

Temperature:	26 °C	Relative Humidity:	54%
Pressure:	101KPa	Phase :	Horizontal
Test Mode:	Mode 4	Test Voltage :	AC 120V/60Hz

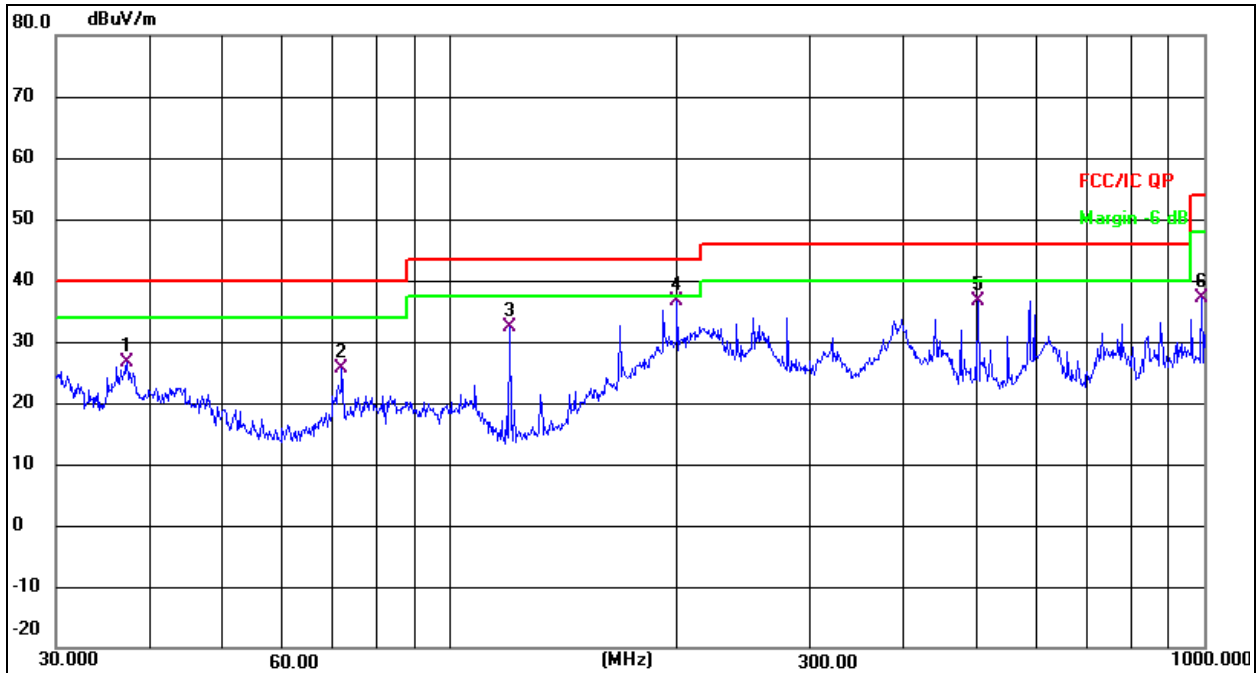
Remark:

1. Factor = Antenna Factor + Cable Loss – Pre-amplifier.
2. Measurement = Reading Level + Correct Factor
3. Over = Measurement - Limit

No.	Frequency (MHz)	Reading (dBuV)	Factor (dB/m)	Level (dBuV/m)	Limit (dBuV/m)	Margin (dB)	Detector
1	37.2854	41.04	-14.32	26.72	40.00	-13.28	QP
2	71.8319	42.53	-16.92	25.61	40.00	-14.39	QP
3	119.8555	49.55	-17.28	32.27	43.50	-11.23	QP
4 *	199.9856	53.68	-17.17	36.51	43.50	-6.99	QP
5	501.1788	42.73	-6.15	36.58	46.00	-9.42	QP
6	993.0113	37.52	-0.29	37.23	54.00	-16.77	QP

Temperature:	26 °C	Relative Humidity:	54%
Pressure:	101KPa	Phase :	Vertical
Test Mode:	Mode 4	Test Voltage :	AC 120V/60Hz

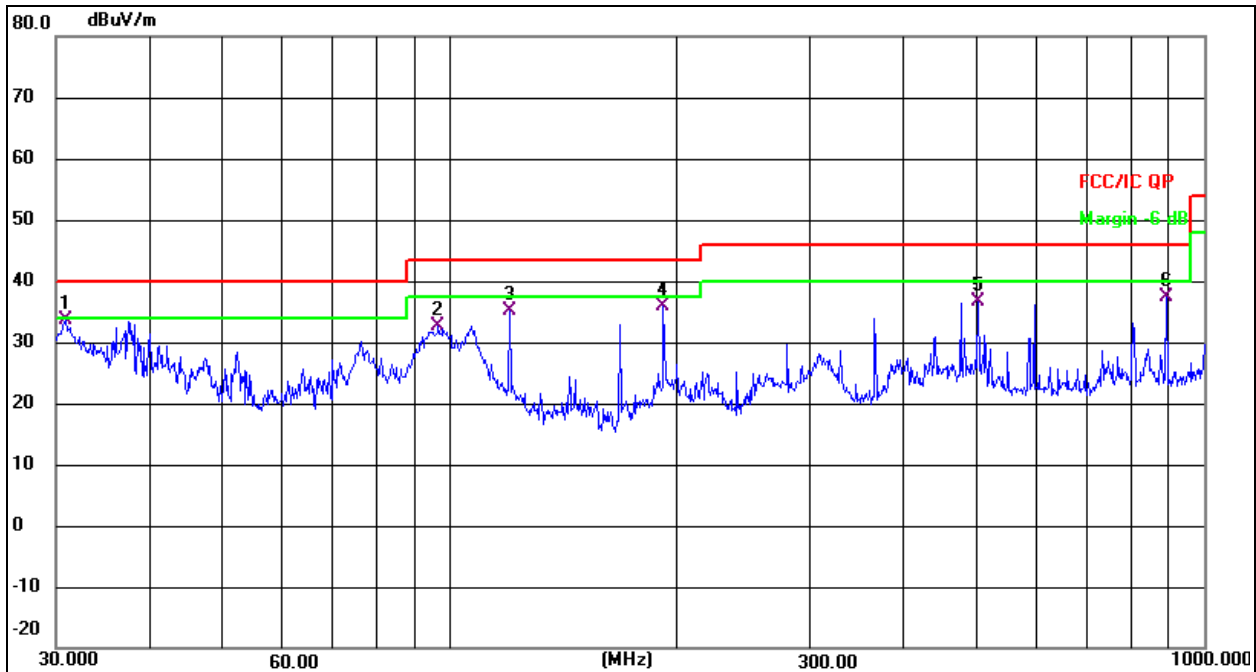
Remark:

1. Factor = Antenna Factor + Cable Loss – Pre-amplifier.
2. Measurement = Reading Level + Correct Factor
3. Over = Measurement - Limit

No.	Frequency (MHz)	Reading (dBuV)	Factor (dB/m)	Level (dBuV/m)	Limit (dBuV/m)	Margin (dB)	Detector
1 *	30.9619	49.04	-15.37	33.67	40.00	-6.33	QP
2	96.4362	51.19	-18.66	32.53	43.50	-10.97	QP
3	119.8556	52.41	-17.28	35.13	43.50	-8.37	QP
4	191.7450	52.76	-16.92	35.84	43.50	-7.66	QP
5	501.1788	42.73	-6.15	36.58	46.00	-9.42	QP
6	890.7277	39.77	-2.41	37.36	46.00	-8.64	QP

BCTC
 3C
 PPR
 检测

Test Mode:	TX(5.1G) - 802.11a
------------	--------------------

Polar (H/V)	Frequency (MHz)	Meter Reading (dBuV)	Cable loss (dB)	Antenna Factor dB/m	Preamp Factor (dB)	Emission Level (dBuV/m)	Limits (dBuV/ m)	Margin (dB)	Detector Type
Low Channel (5180 MHz)-Above 1G									
V	4434.200	63.32	5.94	35.40	44.00	60.66	68.2	-7.54	PK
V	4434.200	43.09	5.94	35.40	44.00	40.43	54	-13.57	AV
V	10360.096	62.60	8.46	39.75	44.50	66.31	68.2	-1.89	PK
V	10360.096	43.09	8.46	39.75	44.50	46.80	54	-7.20	AV
V	15540.053	64.55	10.12	38.80	44.10	69.37	74	-4.63	PK
V	15540.053	43.98	10.12	38.80	42.70	50.20	54	-3.80	AV
H	4434.097	64.01	5.94	35.18	44.00	61.13	68.2	-7.07	PK
H	4434.097	43.29	5.94	35.18	44.00	40.41	54	-13.59	AV
H	10360.073	52.60	8.46	38.71	44.50	55.27	68.2	-12.93	PK
H	10360.073	44.78	8.46	38.71	44.50	47.45	54	-6.55	AV
H	15540.043	50.03	10.12	38.38	44.10	54.43	74	-19.57	PK
H	15540.043	44.49	10.12	38.38	44.10	48.89	54	-5.11	AV
middle Channel (5200 MHz)-Above 1G									
V	4592.197	61.46	6.48	36.35	44.05	60.24	74	-13.76	PK
V	4592.197	43.91	6.48	36.35	44.05	42.69	54	-11.31	AV
V	10400.094	63.53	8.47	37.88	44.51	65.37	68.2	-2.83	PK
V	10400.094	43.68	8.47	37.88	44.51	45.52	54	-8.48	AV
V	15600.090	64.15	10.12	38.80	44.10	68.97	74	-5.03	PK
V	15600.090	43.14	10.12	38.80	42.70	49.36	54	-4.64	AV
H	4592.110	63.79	6.48	36.37	44.05	62.59	74	-11.41	PK
H	4592.110	43.04	6.48	36.37	44.05	41.84	54	-12.16	AV
H	10400.103	54.53	8.47	38.64	44.50	57.14	68.2	-11.06	PK
H	10400.103	44.74	8.47	38.64	44.50	47.35	54	-6.65	AV
H	15600.038	54.92	10.12	38.38	44.10	59.32	74	-14.68	PK
H	15600.038	41.99	10.12	38.38	44.10	46.39	54	-7.61	AV
High Channel (5240 MHz)-Above 1G									
V	4739.014	61.86	7.10	37.24	43.50	62.70	74	-11.30	PK
V	4739.014	43.52	7.10	37.24	43.50	44.36	54	-9.64	AV
V	10480.029	64.11	8.46	37.68	44.50	65.75	68.2	-2.45	PK
V	10480.029	43.81	8.46	37.68	44.50	45.45	54	-8.55	AV
V	15720.127	60.53	10.12	38.80	44.10	65.35	74	-8.65	PK
V	15720.127	43.15	10.12	38.80	42.70	49.37	54	-4.63	AV
H	4739.084	61.05	7.10	37.24	43.50	61.89	74	-12.11	PK
H	4739.084	43.44	7.10	37.24	43.50	44.28	54	-9.72	AV
H	10480.197	53.66	8.46	38.57	44.50	56.19	68.2	-12.01	PK
H	10480.197	41.11	8.46	38.57	44.50	43.64	54	-10.36	AV
H	15720.193	51.48	10.12	38.38	44.10	55.88	74	-18.12	PK
H	15720.193	40.88	10.12	38.38	44.10	45.28	54	-8.72	AV

Note: PK value is lower than the Average value limit, So average didn't record.
 The 26.5-40G amplitude of spurious emissions that are attenuated by more than 20dB below the permissible value has no need to be reported.
 Emission level (dBuV/m) = 20 log Emission level (uV/m).
 Corrected Reading: Antenna Factor + Cable Loss + Read Level - Preamp Factor = Level.

TEST
 TO
 OVER
 檢

Test Mode :	TX(5.1G) - 802.11n-HT20
-------------	-------------------------

Polar (H/V)	Frequency (MHz)	Meter Reading (dBuV)	Cable loss (dB)	Antenna Factor dB/m	Preamp Factor (dB)	Emission Level (dBuV/m)	Limits (dBuV/ m)	Margin (dB)	Detector Type
Low Channel (5180 MHz)-Above 1G									
V	4434.138	62.01	5.94	35.40	44.00	59.35	68.2	-8.85	PK
V	4434.138	43.82	5.94	35.40	44.00	41.16	54	-12.84	AV
V	10360.092	61.14	8.46	39.75	44.50	64.85	68.2	-3.35	PK
V	10360.092	43.05	8.46	39.75	44.50	46.76	54	-7.24	AV
V	15540.008	63.15	10.12	38.80	44.10	67.97	74	-6.03	PK
V	15540.008	43.26	10.12	38.80	42.70	49.48	54	-4.52	AV
H	4434.156	62.27	5.94	35.18	44.00	59.39	68.2	-8.81	PK
H	4434.156	43.99	5.94	35.18	44.00	41.11	54	-12.89	AV
H	10360.063	54.43	8.46	38.71	44.50	57.10	68.2	-11.10	PK
H	10360.063	43.81	8.46	38.71	44.50	46.48	54	-7.52	AV
H	15540.002	50.01	10.12	38.38	44.10	54.41	74	-19.59	PK
H	15540.002	43.47	10.12	38.38	44.10	47.87	54	-6.13	AV
middle Channel (5200 MHz)-Above 1G									
V	4592.159	60.34	6.48	36.35	44.05	59.12	74	-14.88	PK
V	4592.159	43.77	6.48	36.35	44.05	42.55	54	-11.45	AV
V	10400.197	60.43	8.47	37.88	44.51	62.27	68.2	-5.93	PK
V	10400.197	43.05	8.47	37.88	44.51	44.89	54	-9.11	AV
V	15600.068	61.54	10.12	38.80	44.10	66.36	74	-7.64	PK
V	15600.068	43.33	10.12	38.80	42.70	49.55	54	-4.45	AV
H	4592.057	63.19	6.48	36.37	44.05	61.99	74	-12.01	PK
H	4592.057	43.24	6.48	36.37	44.05	42.04	54	-11.96	AV
H	10400.159	53.30	8.47	38.64	44.50	55.91	68.2	-12.29	PK
H	10400.159	42.45	8.47	38.64	44.50	45.06	54	-8.94	AV
H	15600.029	52.09	10.12	38.38	44.10	56.49	74	-17.51	PK
H	15600.029	41.65	10.12	38.38	44.10	46.05	54	-7.95	AV
High Channel (5240 MHz)-Above 1G									
V	4739.072	64.01	7.10	37.24	43.50	64.85	74	-9.15	PK
V	4739.072	43.90	7.10	37.24	43.50	44.74	54	-9.26	AV
V	10480.085	62.16	8.46	37.68	44.50	63.80	68.2	-4.40	PK
V	10480.085	43.13	8.46	37.68	44.50	44.77	54	-9.23	AV
V	15720.197	60.30	10.12	38.80	44.10	65.12	74	-8.88	PK
V	15720.197	43.32	10.12	38.80	42.70	49.54	54	-4.46	AV
H	4739.027	63.73	7.10	37.24	43.50	64.57	74	-9.43	PK
H	4739.027	43.85	7.10	37.24	43.50	44.69	54	-9.31	AV
H	10480.021	53.74	8.46	38.57	44.50	56.27	68.2	-11.93	PK
H	10480.021	43.45	8.46	38.57	44.50	45.98	54	-8.02	AV
H	15720.117	50.49	10.12	38.38	44.10	54.89	74	-19.11	PK
H	15720.117	40.59	10.12	38.38	44.10	44.99	54	-9.01	AV

Note: PK value is lower than the Average value limit, So average didn't record.
 The 26.5-40G amplitude of spurious emissions that are attenuated by more than 20dB below the permissible value has no need to be reported.
 Emission level (dBuV/m) = 20 log Emission level (uV/m).
 Corrected Reading: Antenna Factor + Cable Loss + Read Level - Preamp Factor = Level.



Test Mode :	TX(5.1G) - 802.11n-HT40
-------------	-------------------------

Polar (H/V)	Frequency (MHz)	Meter Reading (dBuV)	Cable loss (dB)	Antenna Factor dB/m	Preamp Factor (dB)	Emission Level (dBuV/m)	Limits (dBuV/ m)	Margin (dB)	Detector Type
Low Channel (5190 MHz)-Above 1G									
V	4434.184	62.99	5.94	35.40	44.00	60.33	68.2	-7.87	PK
V	4434.184	43.94	5.94	35.40	44.00	41.28	54	-12.72	AV
V	10380.018	60.71	8.46	39.75	44.50	64.42	68.2	-3.78	PK
V	10380.018	43.98	8.46	39.75	44.50	47.69	54	-6.31	AV
V	15570.169	63.07	10.12	38.80	44.10	67.89	74	-6.11	PK
V	15570.169	43.92	10.12	38.80	42.70	50.14	54	-3.86	AV
H	4434.133	60.80	5.94	35.18	44.00	57.92	74	-16.08	PK
H	4434.133	43.36	5.94	35.18	44.00	40.48	54	-13.52	AV
H	10380.190	53.68	8.46	38.71	44.50	56.35	68.2	-11.85	PK
H	10380.190	41.59	8.46	38.71	44.50	44.26	54	-9.74	AV
H	15570.096	50.52	10.12	38.38	44.10	54.92	74	-19.08	PK
H	15570.096	40.27	10.12	38.38	44.10	44.67	54	-9.33	AV
middle Channel (5230 MHz)-Above 1G									
V	4739.183	64.14	6.48	36.35	44.05	62.92	68.2	-5.28	PK
V	4739.183	43.05	6.48	36.35	44.05	41.83	54	-12.17	AV
V	10460.166	60.21	8.47	37.88	44.51	62.05	68.2	-6.15	PK
V	10460.166	43.42	8.47	37.88	44.51	45.26	54	-8.74	AV
V	15690.106	63.18	10.12	38.80	44.10	68.00	74	-6.00	PK
V	15690.106	43.20	10.12	38.80	42.70	49.42	54	-4.58	AV
H	4739.001	64.22	6.48	36.37	44.05	63.02	68.2	-5.18	PK
H	4739.001	43.68	6.48	36.37	44.05	42.48	54	-11.52	AV
H	10460.032	50.94	8.47	38.64	44.50	53.55	68.2	-14.65	PK
H	10460.032	44.50	8.47	38.64	44.50	47.11	54	-6.89	AV
H	15690.002	54.79	10.12	38.38	44.10	59.19	74	-14.81	PK
H	15690.002	40.66	10.12	38.38	44.10	45.06	54	-8.94	AV

Note: PK value is lower than the Average value limit, So average didn't record.
 The 26.5-40G amplitude of spurious emissions that are attenuated by more than 20dB below the permissible value has no need to be reported.
 Emission level (dBuV/m) = 20 log Emission level (uV/m).
 Corrected Reading: Antenna Factor + Cable Loss + Read Level - Preamp Factor = Level.

CO.LTD

Test Mode:	TX(5.1G) - 802.11ac-HT20
------------	--------------------------

Polar (H/V)	Frequency	Meter Reading	Cable loss	Antenna Factor	Preamp Factor	Emission Level	Limits	Margin	Detector Type
	(MHz)	(dBuV)	(dB)	dB/m	(dB)	(dBuV/m)	(dBuV/m)	(dB)	
Low Channel (5180 MHz)-Above 1G									
V	4434.114	61.99	5.94	35.40	44.00	59.33	68.2	-8.87	PK
V	4434.114	43.18	5.94	35.40	44.00	40.52	54	-13.48	AV
V	10360.121	63.87	8.46	39.75	44.50	67.58	68.2	-0.62	PK
V	10360.121	43.35	8.46	39.75	44.50	47.06	54	-6.94	AV
V	15540.074	64.28	10.12	38.80	44.10	69.10	74	-4.90	PK
V	15540.074	43.95	10.12	38.80	42.70	50.17	54	-3.83	AV
H	4434.095	64.48	5.94	35.18	44.00	61.60	68.2	-6.60	PK
H	4434.095	43.25	5.94	35.18	44.00	40.37	54	-13.63	AV
H	10360.187	53.04	8.46	38.71	44.50	55.71	68.2	-12.49	PK
H	10360.187	41.67	8.46	38.71	44.50	44.34	54	-9.66	AV
H	15540.104	52.07	10.12	38.38	44.10	56.47	74	-17.53	PK
H	15540.104	44.53	10.12	38.38	44.10	48.93	54	-5.07	AV
Middle Channel (5200 MHz)-Above 1G									
V	4592.009	60.08	6.48	36.35	44.05	58.86	74	-15.14	PK
V	4592.009	43.02	6.48	36.35	44.05	41.80	54	-12.20	AV
V	10400.200	61.02	8.47	37.88	44.51	62.86	68.2	-5.34	PK
V	10400.200	43.44	8.47	37.88	44.51	45.28	54	-8.72	AV
V	15600.187	62.96	10.12	38.80	44.10	67.78	74	-6.22	PK
V	15600.187	43.13	10.12	38.80	42.70	49.35	54	-4.65	AV
H	4592.035	64.26	6.48	36.37	44.05	63.06	74	-10.94	PK
H	4592.035	43.68	6.48	36.37	44.05	42.48	54	-11.52	AV
H	10400.042	51.65	8.47	38.64	44.50	54.26	68.2	-13.94	PK
H	10400.042	45.00	8.47	38.64	44.50	47.61	54	-6.39	AV
H	15600.129	52.11	10.12	38.38	44.10	56.51	74	-17.49	PK
H	15600.129	43.61	10.12	38.38	44.10	48.01	54	-5.99	AV
High Channel (5240 MHz)-Above 1G									
V	4739.030	62.63	7.10	37.24	43.50	63.47	74	-10.53	PK
V	4739.030	43.25	7.10	37.24	43.50	44.09	54	-9.91	AV
V	10480.008	61.24	8.46	37.68	44.50	62.88	68.2	-5.32	PK
V	10480.008	43.10	8.46	37.68	44.50	44.74	54	-9.26	AV
V	15720.106	62.31	10.12	38.80	44.10	67.13	74	-6.87	PK
V	15720.106	43.90	10.12	38.80	42.70	50.12	54	-3.88	AV
H	4739.117	62.85	7.10	37.24	43.50	63.69	74	-10.31	PK
H	4739.117	43.49	7.10	37.24	43.50	44.33	54	-9.67	AV
H	10480.049	53.16	8.46	38.57	44.50	55.69	68.2	-12.51	PK
H	10480.049	41.02	8.46	38.57	44.50	43.55	54	-10.45	AV
H	15720.118	54.62	10.12	38.38	44.10	59.02	74	-14.98	PK
H	15720.118	44.51	10.12	38.38	44.10	48.91	54	-5.09	AV

Note: PK value is lower than the Average value limit, So average didn't record.
 The 26.5-40G amplitude of spurious emissions that are attenuated by more than 20dB below the permissible value has no need to be reported.
 Emission level (dBuV/m) = 20 log Emission level (uV/m).
 Corrected Reading: Antenna Factor + Cable Loss + Read Level - Preamp Factor = Level.

CHENZHEN

Test Mode:	TX(5.1G) - 802.11ac-HT40
------------	--------------------------

Polar (H/V)	Frequency	Meter Reading	Cable loss	Antenna Factor	Preamp Factor	Emission Level	Limits	Margin	Detector Type
	(MHz)	(dBuV)	(dB)	dB/m	(dB)	(dBuV/m)	(dBuV/m)	(dB)	
Low Channel (5190 MHz)-Above 1G									
V	4434.047	62.17	5.94	35.40	44.00	59.51	68.2	-8.69	PK
V	4434.047	43.11	5.94	35.40	44.00	40.45	54	-13.55	AV
V	10380.092	60.01	8.46	39.75	44.50	63.72	68.2	-4.48	PK
V	10380.092	43.36	8.46	39.75	44.50	47.07	54	-6.93	AV
V	15570.141	63.18	10.12	38.80	44.10	68.00	74	-6.00	PK
V	15570.141	43.70	10.12	38.80	42.70	49.92	54	-4.08	AV
H	4434.143	61.08	5.94	35.18	44.00	58.20	74	-15.80	PK
H	4434.143	43.34	5.94	35.18	44.00	40.46	54	-13.54	AV
H	10380.054	51.51	8.46	38.71	44.50	54.18	68.2	-14.02	PK
H	10380.054	42.56	8.46	38.71	44.50	45.23	54	-8.77	AV
H	15570.055	50.97	10.12	38.38	44.10	55.37	74	-18.63	PK
H	15570.055	44.70	10.12	38.38	44.10	49.10	54	-4.90	AV
High Channel (5230 MHz)-Above 1G									
V	4739.114	61.84	6.48	36.35	44.05	60.62	68.2	-7.58	PK
V	4739.114	43.10	6.48	36.35	44.05	41.88	54	-12.12	AV
V	10460.186	62.26	8.47	37.88	44.51	64.10	68.2	-4.10	PK
V	10460.186	43.29	8.47	37.88	44.51	45.13	54	-8.87	AV
V	15690.120	62.50	10.12	38.80	44.10	67.32	74	-6.68	PK
V	15690.120	43.84	10.12	38.80	42.70	50.06	54	-3.94	AV
H	4739.056	61.58	6.48	36.37	44.05	60.38	68.2	-7.82	PK
H	4739.056	43.33	6.48	36.37	44.05	42.13	54	-11.87	AV
H	10460.004	51.30	8.47	38.64	44.50	53.91	68.2	-14.29	PK
H	10460.004	44.64	8.47	38.64	44.50	47.25	54	-6.75	AV
H	15690.053	52.94	10.12	38.38	44.10	57.34	74	-16.66	PK
H	15690.053	40.60	10.12	38.38	44.10	45.00	54	-9.00	AV

Note: PK value is lower than the Average value limit, So average didn't record.
 The 26.5-40G amplitude of spurious emissions that are attenuated by more than 20dB below the permissible value has no need to be reported.
 Emission level (dBuV/m) = 20 log Emission level (uV/m).
 Corrected Reading: Antenna Factor + Cable Loss + Read Level - Preamp Factor = Level.



Test Mode:	TX(5.1G) - 802.11ac-HT80
------------	--------------------------

Polar (H/V)	Frequency	Meter Reading	Cable loss	Antenna Factor	Preamp Factor	Emission Level	Limits	Margin	Detector Type
	(MHz)	(dBuV)	(dB)	dB/m	(dB)	(dBuV/m)	(dBuV/m)	(dB)	
(5210 MHz)-Above 1G									
V	4434.043	63.63	5.94	35.40	44.00	60.97	68.2	-7.23	PK
V	4434.043	43.59	5.94	35.40	44.00	40.93	54	-13.07	AV
V	10420.029	60.41	8.46	39.75	44.50	64.12	68.2	-4.08	PK
V	10420.029	43.99	8.46	39.75	44.50	47.70	54	-6.30	AV
V	15630.040	63.91	10.12	38.80	44.10	68.73	74	-5.27	PK
V	15630.040	43.86	10.12	38.80	42.70	50.08	54	-3.92	AV
H	4434.037	63.75	5.94	35.18	44.00	60.87	68.2	-7.33	PK
H	4434.037	43.70	5.94	35.18	44.00	40.82	54	-13.18	AV
H	10420.081	50.61	8.46	38.71	44.50	53.28	68.2	-14.92	PK
H	10420.081	42.39	8.46	38.71	44.50	45.06	54	-8.94	AV
H	15630.117	53.96	10.12	38.38	44.10	58.36	74	-15.64	PK
H	15630.117	44.73	10.12	38.38	44.10	49.13	54	-4.87	AV

Note: PK value is lower than the Average value limit, So average didn't record.

The 26.5-40G amplitude of spurious emissions that are attenuated by more than 20dB below the permissible value has no need to be reported.

Emission level (dBuV/m) = 20 log Emission level (uV/m).

Corrected Reading: Antenna Factor + Cable Loss + Read Level - Preamp Factor = Level.

BCTC
 BCTC
 PPR
 检测

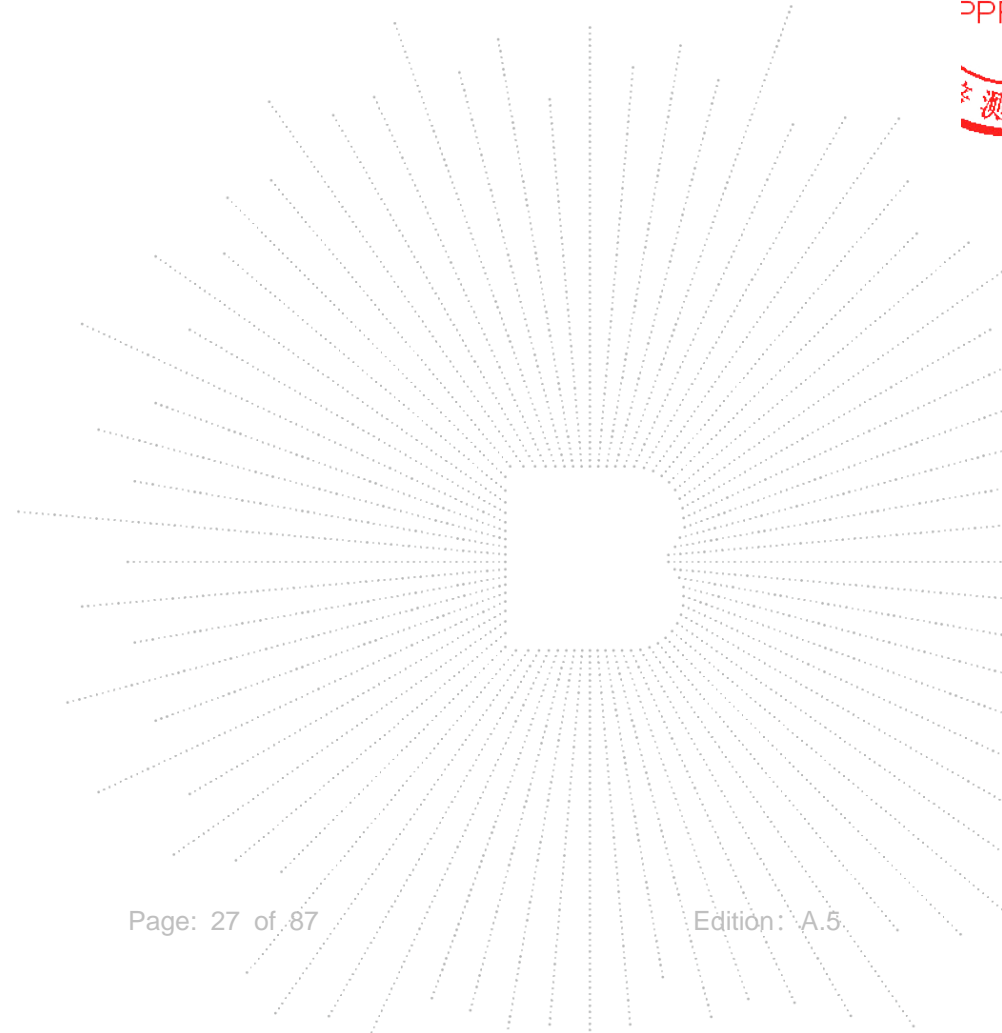

8. Power Spectral Density Test

8.1 Block Diagram Of Test Setup

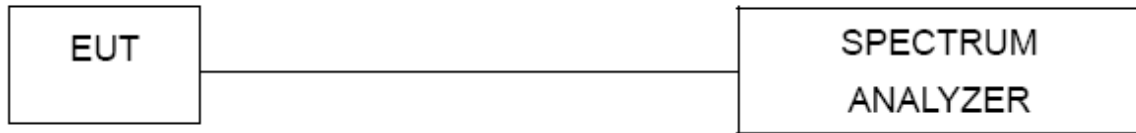

8.2 Limit

According to RSS-247 Issue 2, section 6.2, Power and unwanted emissions limits as below:

Section 6.2.1.1 For frequency band 5150-5250 MHz, For OEM devices installed in vehicles, the maximum e.i.r.p. shall not exceed 30 mW or $1.76 + 10 \log_{10} B$, dBm, whichever is less stringent. Devices shall implement transmitter power control (TPC) in order to have the capability to operate at least 3 dB below the maximum permitted e.i.r.p. of 30 mW.

For other devices, the maximum e.i.r.p. shall not exceed 200 mW or $10 + 10 \log_{10} B$, dBm, whichever power is less. B is the 99% emission bandwidth in megahertz. The e.i.r.p. spectral density shall not exceed 10 dBm in any 1.0 MHz band.

Section 6.2.2.1 For Frequency band 5250-5350 MHz, For OEM devices installed in vehicles, the maximum e.i.r.p. shall not exceed 30 mW or $1.76 + 10 \log_{10} B$, dBm, whichever is less. Devices shall implement TPC in order to have the capability to operate at least 3 dB below the maximum permitted e.i.r.p. of 30 mW.

Devices, other than devices installed in vehicles, shall comply with the following:

- The maximum conducted output power shall not exceed 250 mW or $11 + 10 \log_{10} B$, dBm, whichever is less. The power spectral density shall not exceed 11 dBm in any 1.0 MHz band;
- The maximum e.i.r.p. shall not exceed 1.0 W or $17 + 10 \log_{10} B$, dBm, whichever is less. B is the 99% emission bandwidth in megahertz. Note that devices with a maximum e.i.r.p. greater than 500 mW shall implement TPC in order to have the capability to operate at least 6 dB below the maximum permitted e.i.r.p. of 1 W.

Section 6.2.3.1 For Frequency bands 5470-5600 MHz and 5650-5725 MHz, The maximum conducted output power shall not exceed 250 mW or $11 + 10 \log_{10} B$, dBm, whichever is less. The power spectral density shall not exceed 11 dBm in any 1.0 MHz band.

The maximum e.i.r.p. shall not exceed 1.0 W or $17 + 10 \log_{10} B$, dBm, whichever is less. B is the 99% emission bandwidth in megahertz. Note that devices with a maximum e.i.r.p. greater than 500 mW shall implement TPC in order to have the capability to operate at least 6 dB below the maximum permitted e.i.r.p. of 1 W.

Section 6.2.4.1 For Frequency band 5725-5850 MHz, For equipment operating in the band 5725-5850 MHz, the minimum 6 dB bandwidth shall be at least 500 kHz.

The maximum conducted output power shall not exceed 1 W. The output power spectral density shall not exceed 30 dBm in any 500 kHz band. If transmitting antennas of directional gain greater than 6 dBi are used, both the maximum conducted output power and the output power spectral density shall be reduced by the amount in dB that the directional gain of the antenna exceeds 6 dBi. However, fixed point-to-point devices operating in this band may employ transmitting antennas with directional gain greater than 6 dBi without any corresponding reduction in transmitter conducted power. Fixed point-to-point operations exclude the use of point-to-multipoint systems, omnidirectional applications and multiple collocated transmitters transmitting the same information.

8.3 Test Procedure

According to 789033 D02 General UNII Test Procedures New Rules v01, the following is the measurement procedure.

For devices operating in the bands 5.15-5.25 GHz, 5.25-5.35 GHz, and 5.47-5.725 GHz, the above procedures make use of 1 MHz RBW to satisfy directly the 1 MHz reference bandwidth specified in § 15.407(a)(5). For devices operating in the band 5.725-5.85 GHz, the rules specify a measurement bandwidth of 500 kHz. Many spectrum analyzers do not have 500 kHz RBW, thus a narrower RBW may need to be used. The rules permit the use of a RBWs less than 1 MHz, or 500 kHz, “provided that the measured power is integrated over the full reference bandwidth” to show the total power over the specified measurement bandwidth (i.e., 1 MHz, or 500 kHz). If measurements are performed using a reduced resolution bandwidth (< 1 MHz, or < 500 kHz) and integrated over 1 MHz, or 500 kHz bandwidth, the following adjustments to the procedures apply:

- a) Set $RBW \geq 1/T$, where T is defined in section II.B.I.a).
- b) Set $VBW \geq 3 RBW$.
- c) If measurement bandwidth of Maximum PSD is specified in 500 kHz, add $10\log(500\text{kHz}/RBW)$ to the measured result, whereas RBW (< 500 kHz) is the reduced resolution bandwidth of the spectrum analyzer set during measurement.
- d) If measurement bandwidth of Maximum PSD is specified in 1 MHz, add $10\log(1\text{MHz}/RBW)$ to the measured result, whereas RBW (< 1 MHz) is the reduced resolution bandwidth of spectrum analyzer set during measurement.
- e) Care must be taken to ensure that the measurements are performed during a period of continuous transmission or are corrected upward for duty cycle.

Note: As a practical matter, it is recommended to use reduced RBW of 100 KHz for the sections 5.c) and 5.d) above, since RBW=100 KHz is available on nearly all spectrum analyzers.

8.4 EUT operating Conditions

The EUT was configured for testing in a typical fashion (as a customer would normally use it). The EUT has been programmed to continuously transmit during test. This operating condition was tested and used to collect the included data.

8.5 Test Result

Temperature:	26 °C	Relative Humidity:	54%
Pressure:	101KPa	Test Voltage:	DC 12V
Test Mode:	(5180-5240MHz)		

Condition	Mode	Frequency (MHz)	Conducted PSD (dBm)	EIRP PSD (dBm/MHz)	Limit (dBm)	Verdict
NVNT	a	5180	-4.14	-0.04	10	Pass
NVNT	a	5200	-4.24	-0.14	10	Pass
NVNT	a	5240	-3.49	0.61	10	Pass
NVNT	n20	5180	-5.5	-1.40	10	Pass
NVNT	n20	5200	-5.86	-1.76	10	Pass
NVNT	n20	5240	-6.27	-2.17	10	Pass
NVNT	n40	5190	-12.26	-8.16	10	Pass
NVNT	n40	5230	-11.83	-7.73	10	Pass
NVNT	ac20	5180	-4.91	-0.81	10	Pass
NVNT	ac20	5200	-7.1	-3.00	10	Pass
NVNT	ac20	5240	-6.32	-2.22	10	Pass
NVNT	ac40	5190	-9.34	-5.24	10	Pass
NVNT	ac40	5230	-9.45	-5.35	10	Pass
NVNT	ac80	5210	-19.07	-14.97	10	Pass

Note:

1.EIRP PSD= Conducted PSD +Antenna Gain, Antenna Gain=4.1 dBi

CO.,LTD

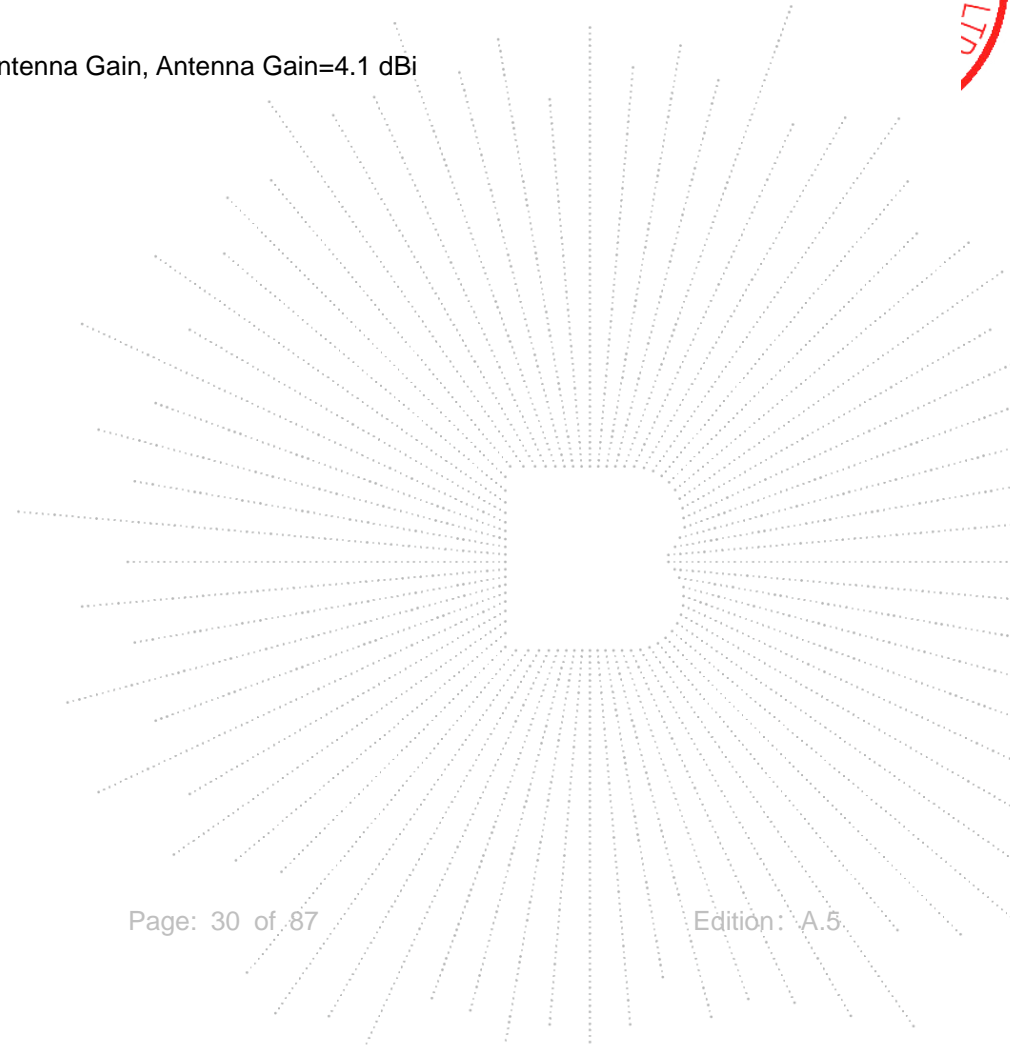

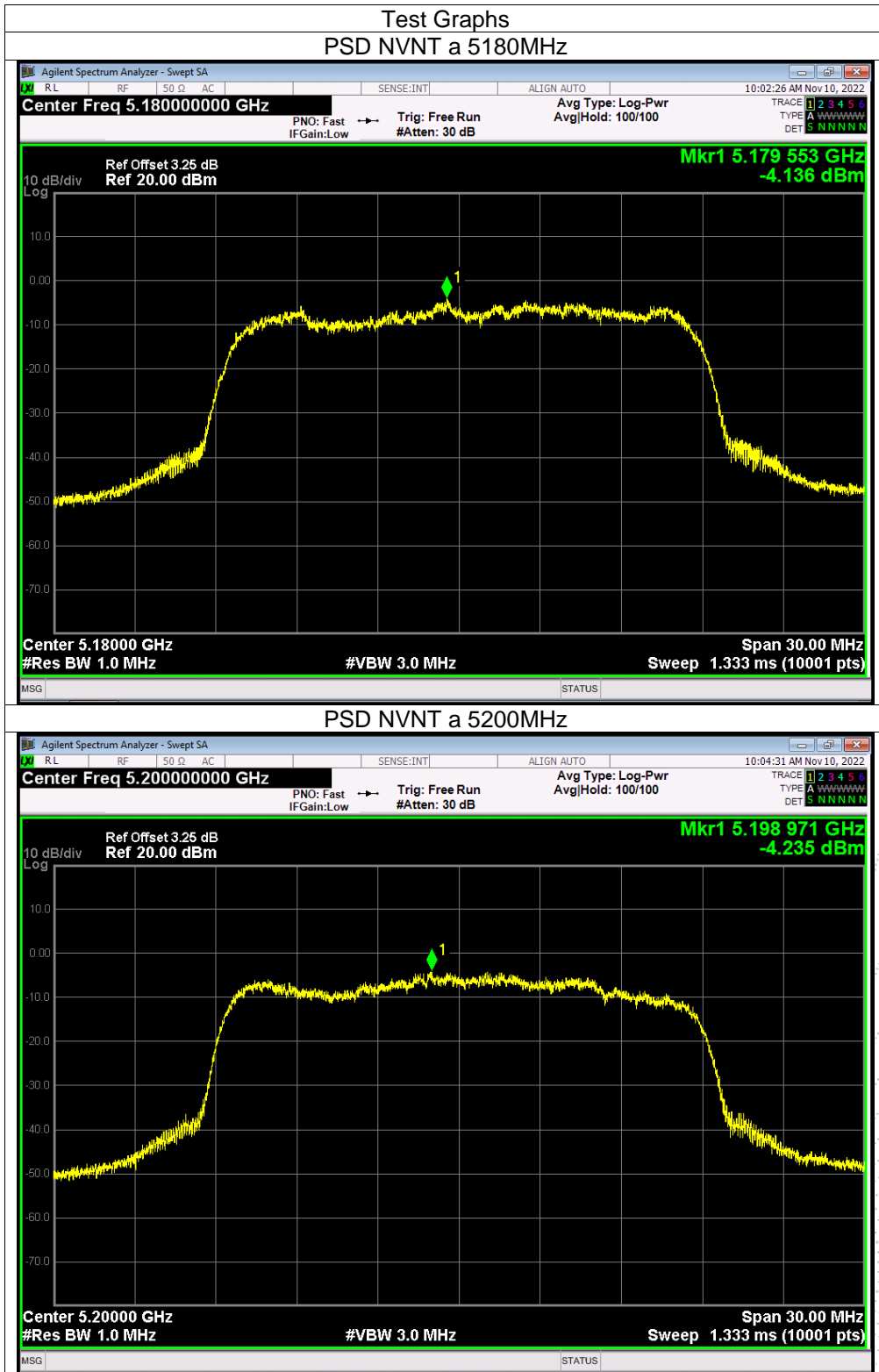

SHENZHEN

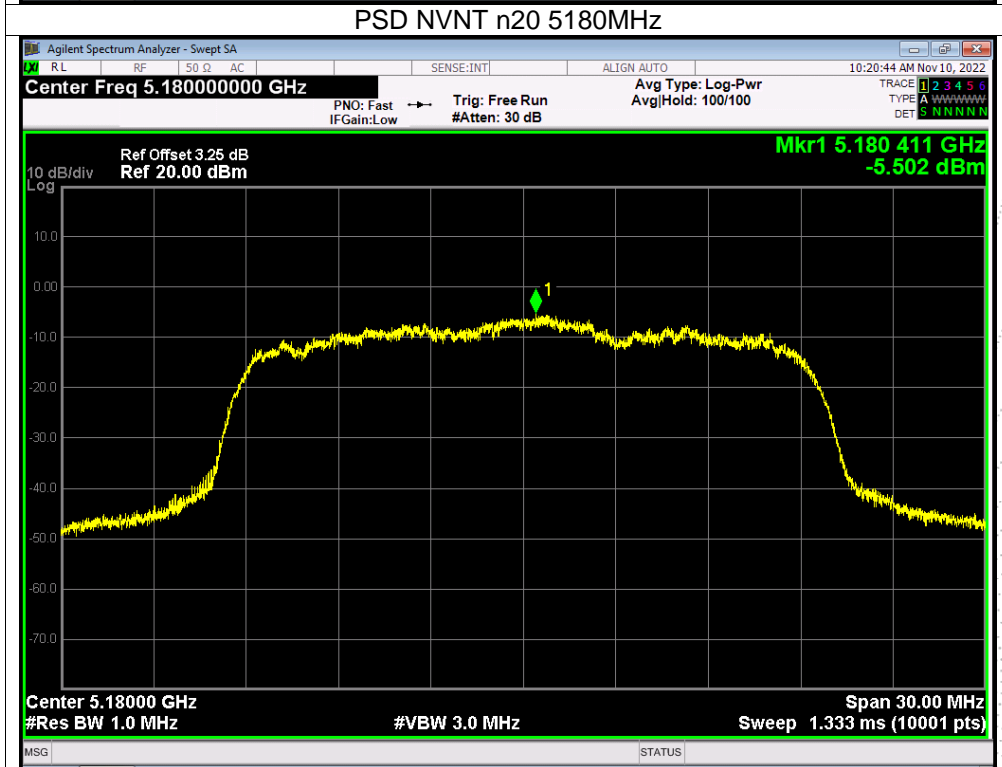
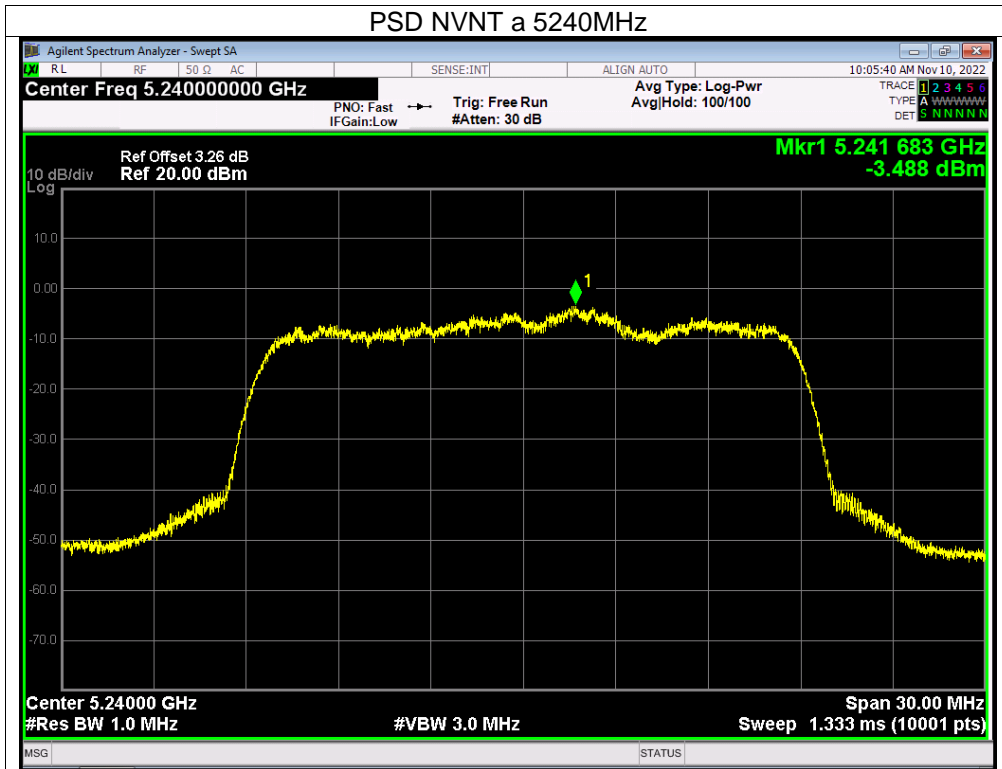

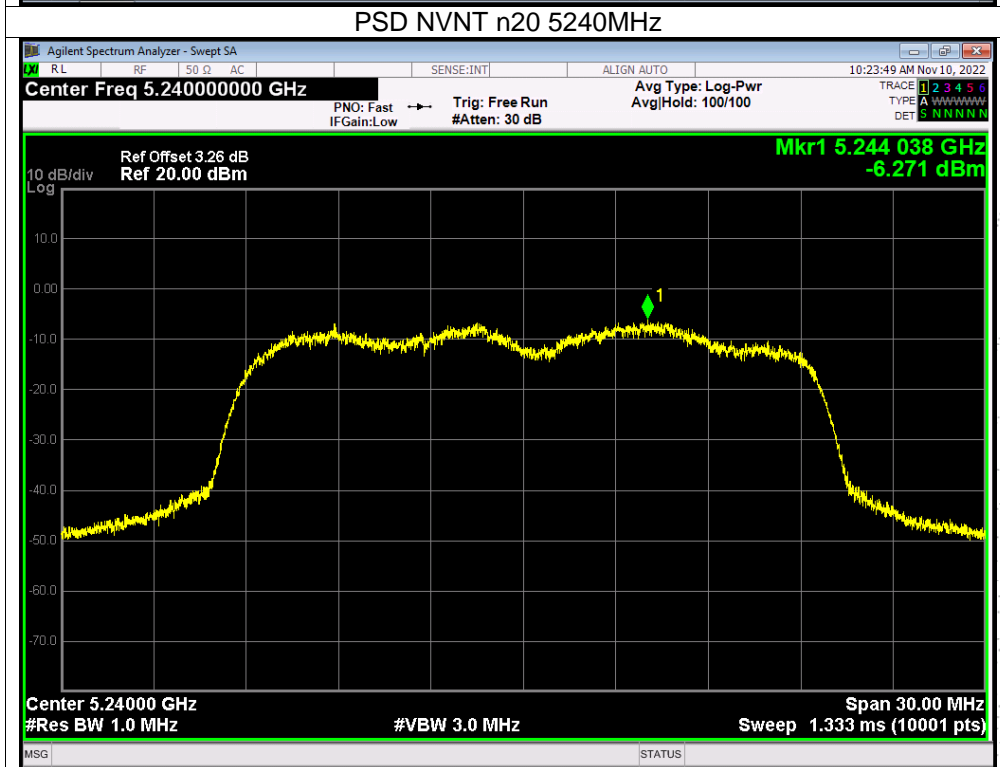
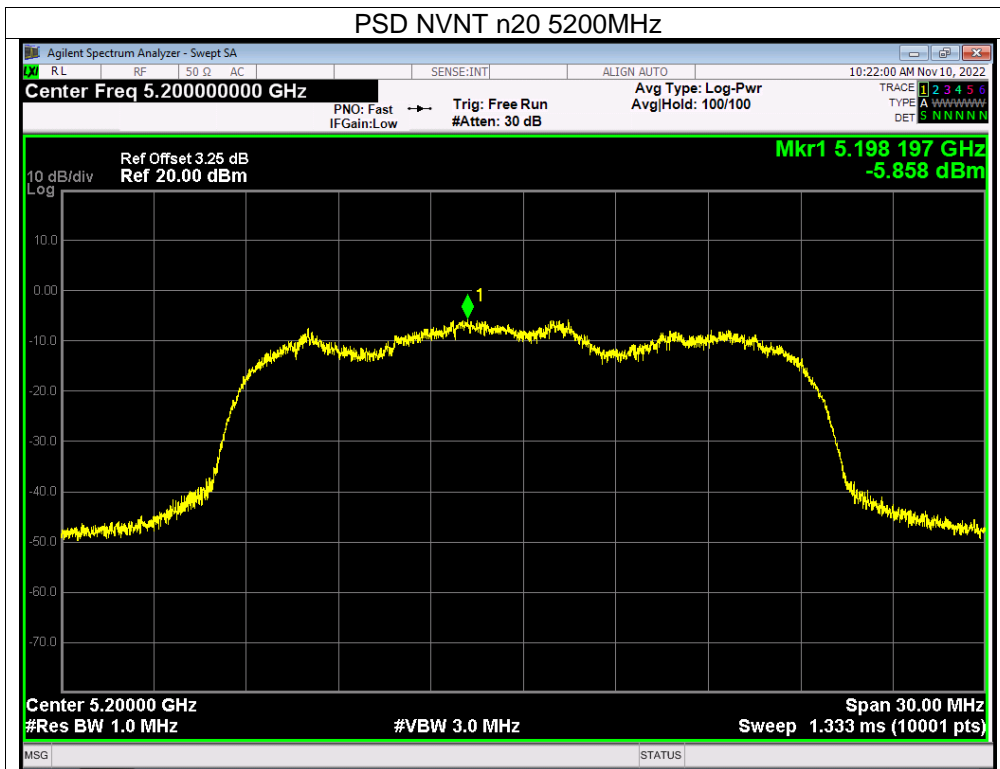

BCTC
 3C
 PPR
 检测

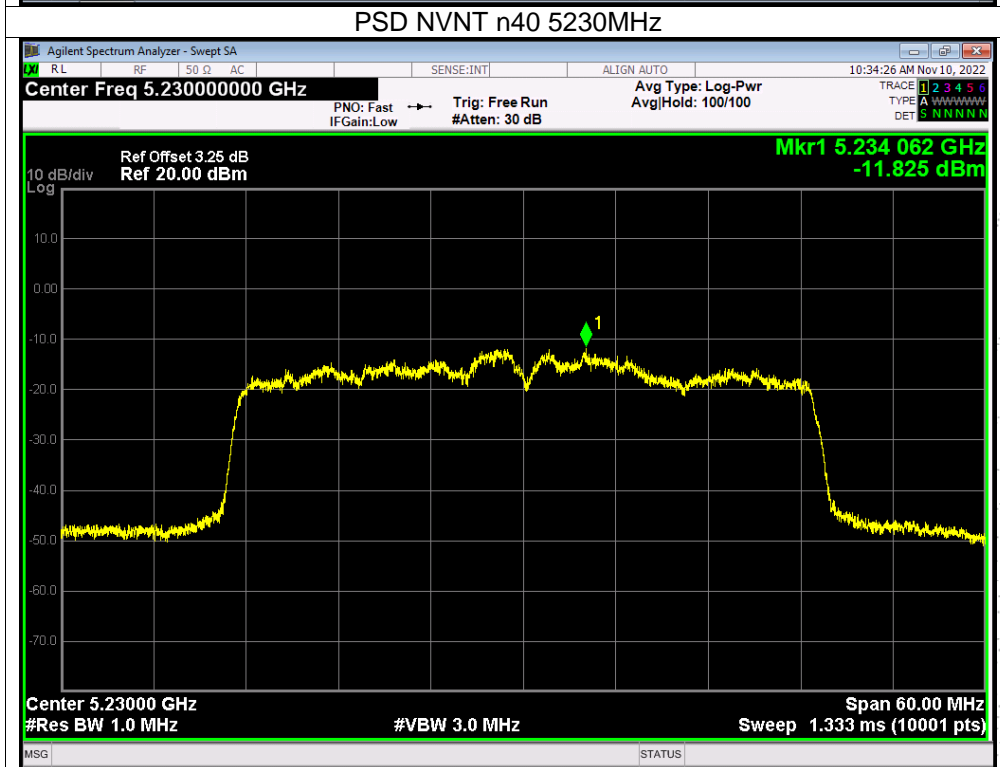
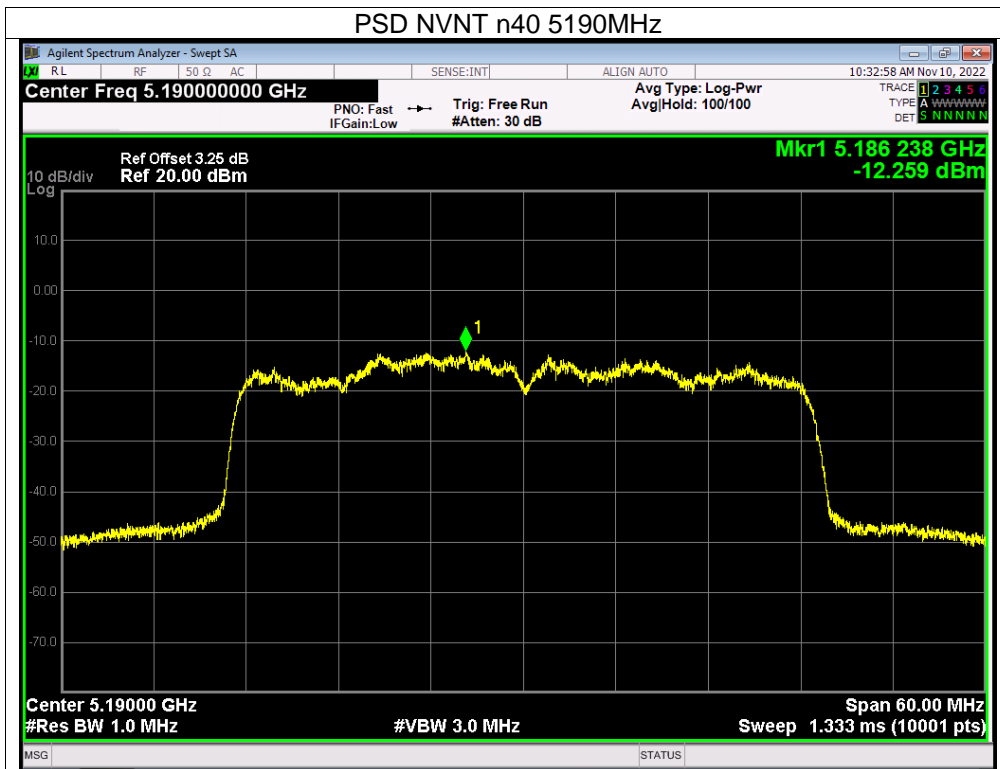

TEST
 TO
 OVER
 検査

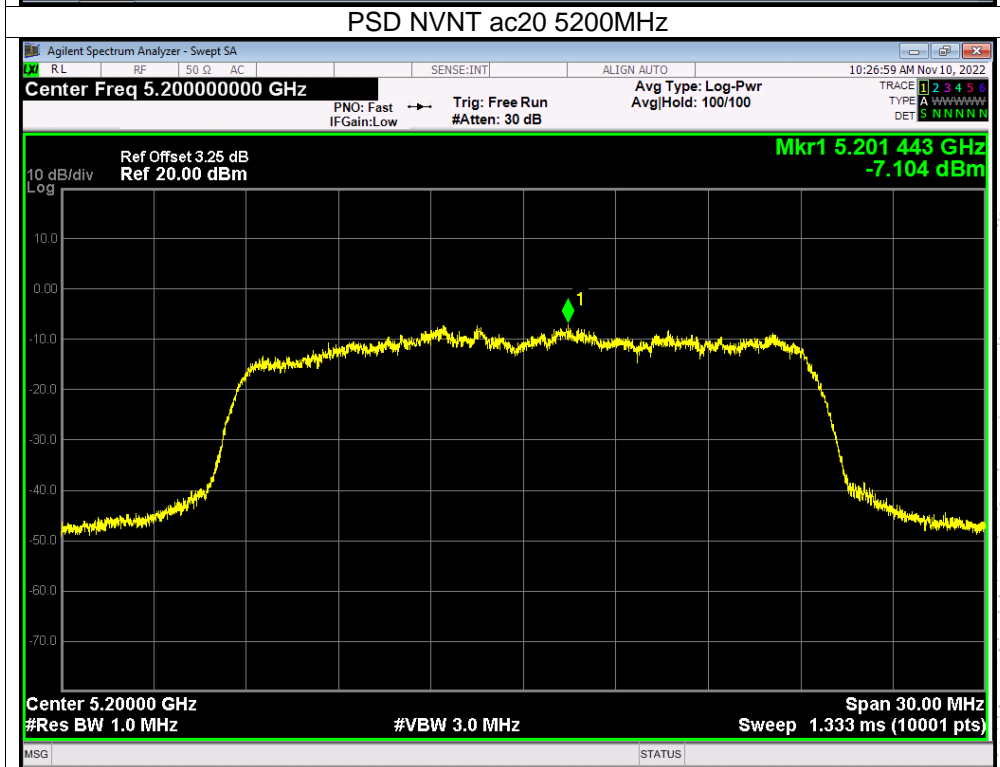
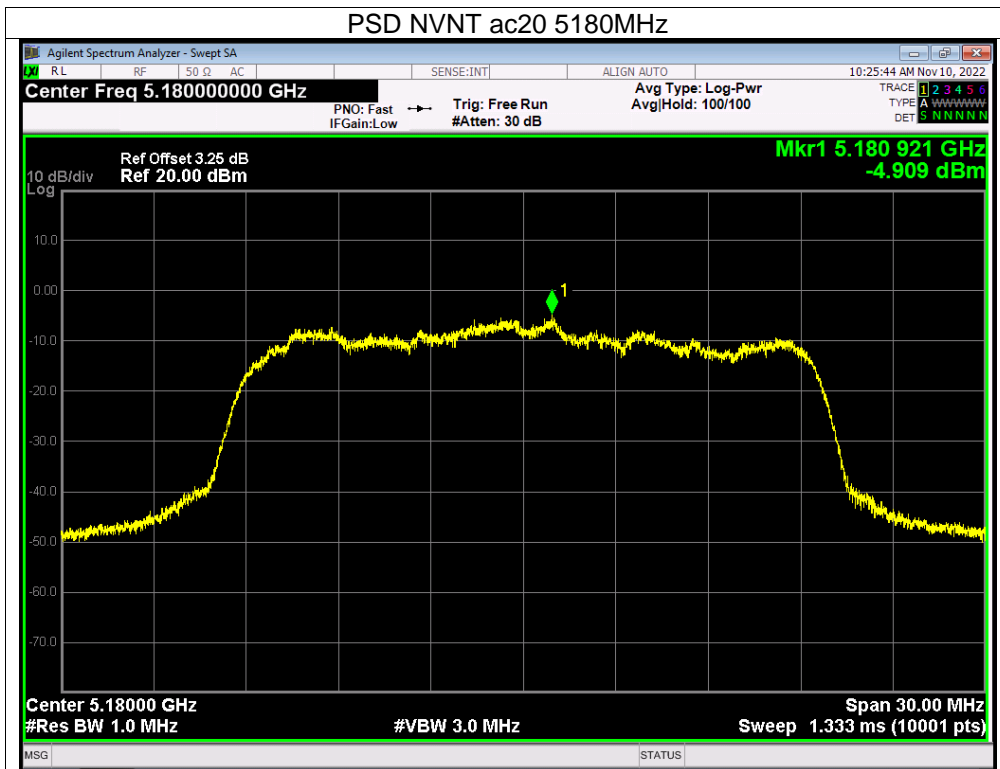

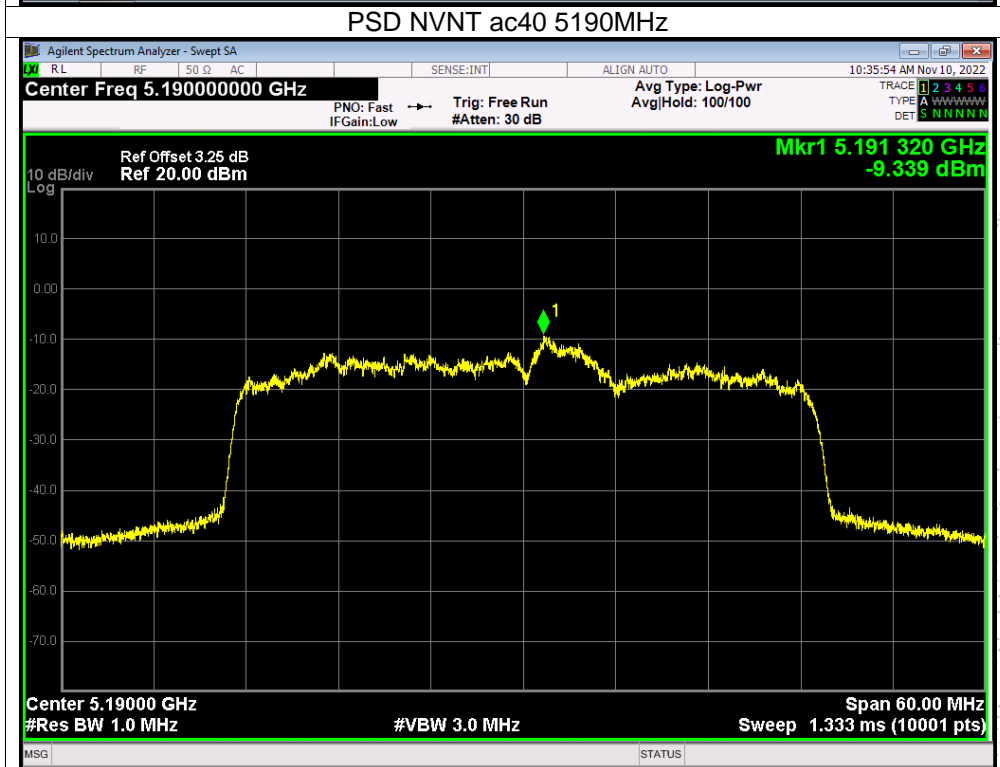
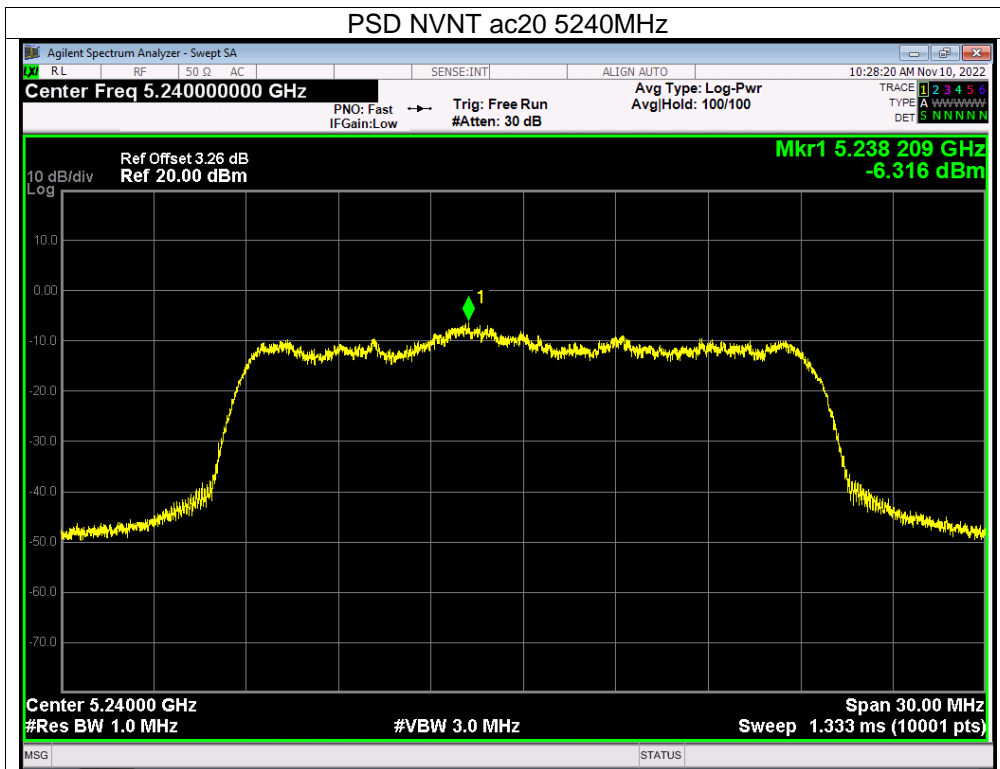

CO., LTD

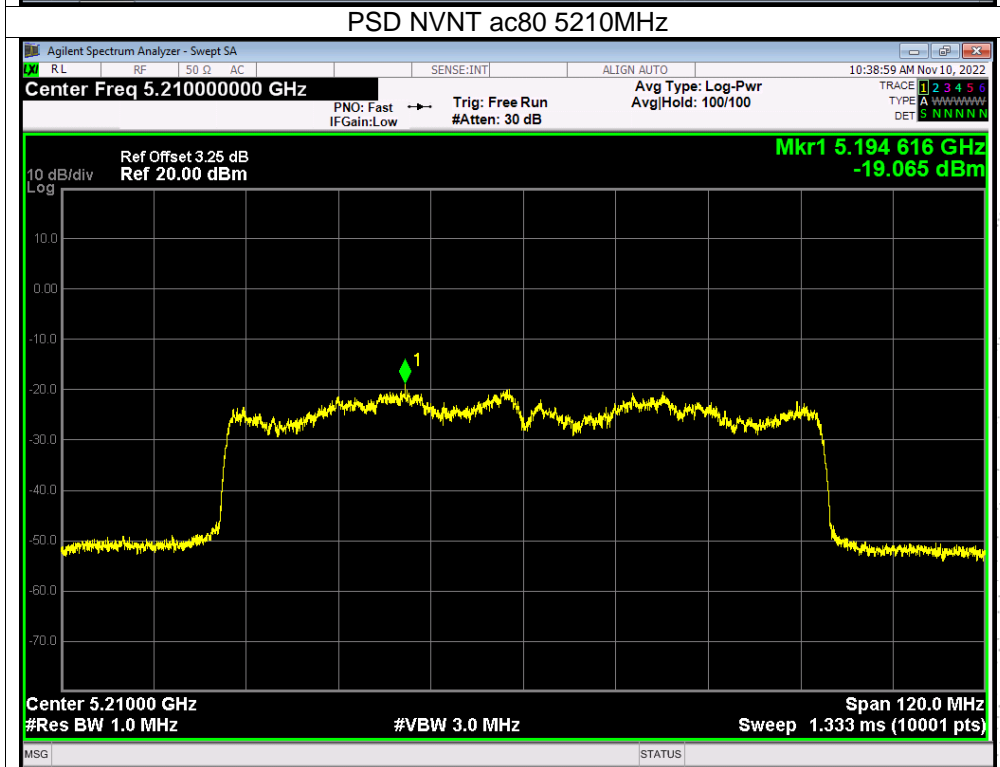
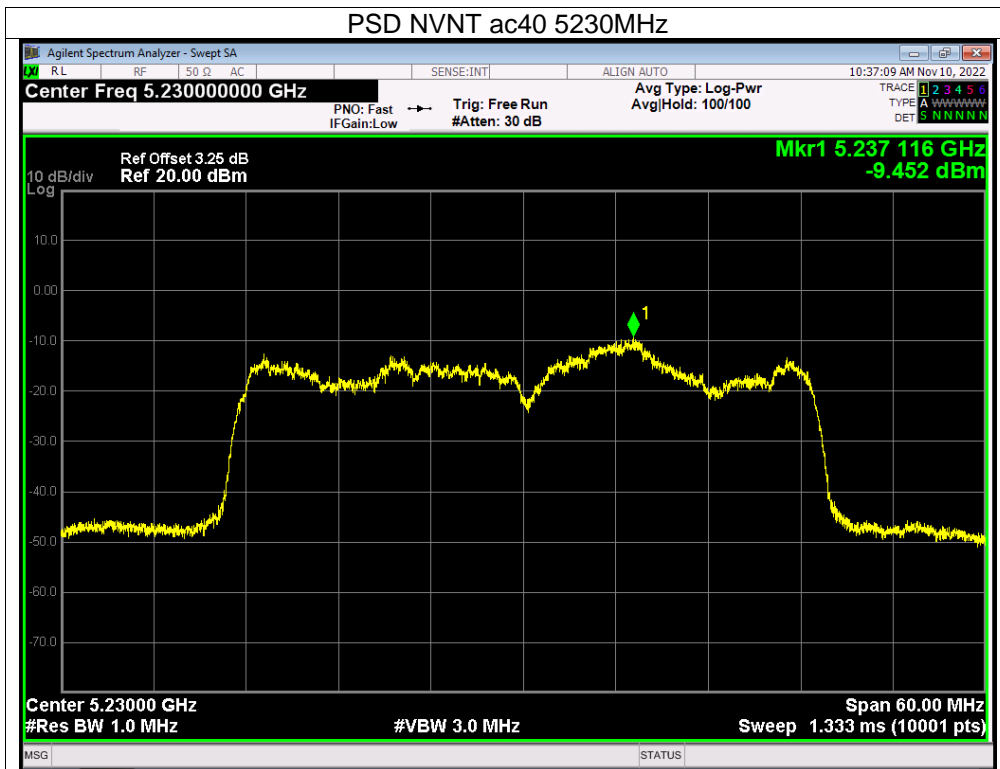

SHENZHEN

9. 26dB & 99% Emission Bandwidth

9.1 Block Diagram Of Test Setup

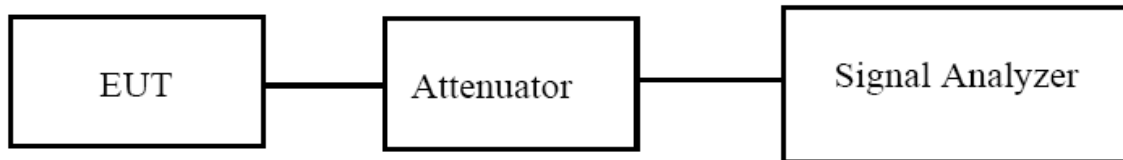

9.2 Limit

According to RSS-247 Issue 2 section 6.2, Power and unwanted emissions limits as below:

Section 6.2.1.1 For frequency band 5150-5250 MHz, For OEM devices installed in vehicles, the maximum e.i.r.p. shall not exceed 30 mW or $1.76 + 10 \log_{10} B$, dBm, whichever is less stringent. Devices shall implement transmitter power control (TPC) in order to have the capability to operate at least 3 dB below the maximum permitted e.i.r.p. of 30 mW., For other devices, the maximum e.i.r.p. shall not exceed 200 mW or $10 + 10 \log_{10} B$, dBm, whichever power is less. B is the 99% emission bandwidth in megahertz. The e.i.r.p. spectral density shall not exceed 10 dBm in any 1.0 MHz band.

Section 6.2.4.1 For Frequency band 5725-5850 MHz, For equipment operating in the band 5725-5850 MHz, the minimum 6 dB bandwidth shall be at least 500 kHz.

The maximum conducted output power shall not exceed 1 W. The output power spectral density shall not exceed 30 dBm in any 500 kHz band. If transmitting antennas of directional gain greater than 6 dBi are used, both the maximum conducted output power and the output power spectral density shall be reduced by the amount in dB that the directional gain of the antenna exceeds 6 dBi. However, fixed point-to-point devices operating in this band may employ transmitting antennas with directional gain greater than 6 dBi without any corresponding reduction in transmitter conducted power. Fixed point-to-point operations exclude the use of point-to-multipoint systems, omnidirectional applications and multiple collocated transmitters transmitting the same information.

9.3 Test procedure

According to 789033 D02 v01r02 section C&D, the following is the measurement procedure.

1. Emission Bandwidth (EBW)

- a) Set RBW = approximately 1% of the emission bandwidth.
- b) Set the VBW > RBW.
- c) Detector = Peak.
- d) Trace mode = max hold.
- e) Measure the maximum width of the emission that is 26 dB down from the maximum of the emission. Compare this with the RBW setting of the analyzer. Readjust RBW and repeat measurement as needed until the RBW/EBW ratio is approximately 1%.

2. Minimum Emission Bandwidth for the band 5.725-5.85 GHz

Section 15.407(e) specifies the minimum 6 dB emission bandwidth of at least 500 KHz for the band 5.715-5.85 GHz. The following procedure shall be used for measuring this bandwidth:

- a) Set RBW = 100 kHz.
- b) Set the video bandwidth (VBW) $\geq 3 \times$ RBW.
- c) Detector = Peak.
- d) Trace mode = max hold.
- e) Sweep = auto couple.
- f) Allow the trace to stabilize.
- g) Measure the maximum width of the emission that is constrained by the frequencies associated with the two outermost amplitude points (upper and lower frequencies) that are attenuated by 6 dB relative to the maximum level measured in the fundamental emission.

Note: The automatic bandwidth measurement capability of a spectrum analyzer or EMI receiver may be employed if it implements the functionality described above.

D. 99 Percent Occupied Bandwidth

The 99-percent occupied bandwidth is the frequency bandwidth such that, below its lower and above its upper frequency limits, the mean powers are each equal to 0.5 % of the total mean power of the given emission. Measurement of the 99-percent occupied bandwidth is required only as a condition for using the optional band-edge measurement techniques described in section II.G.3.d). Measurements of 99-percent occupied bandwidth may also optionally be used in lieu of the EBW to 789033 D02 v01r02 General UNII Test Procedures New Rules v01 define the minimum frequency range over which the spectrum is integrated when measuring maximum conducted output power as described in section II.E. However, the EBW must be measured to determine bandwidth dependent limits on maximum conducted output power in accordance with 15.407(a).

The following procedure shall be used for measuring (99 %) power bandwidth:

1. Set center frequency to the nominal EUT channel center frequency.
2. Set span = 1.5 times to 5.0 times the OBW.
3. Set RBW = 1 % to 5 % of the OBW
4. Set VBW $\geq 3 \cdot$ RBW
5. Video averaging is not permitted. Where practical, a sample detection and single sweep mode shall be used. Otherwise, peak detection and max hold mode (until the trace stabilizes) shall be used.
6. Use the 99 % power bandwidth function of the instrument (if available).
7. If the instrument does not have a 99 % power bandwidth function, the trace data points are recovered and directly summed in power units. The recovered amplitude data points, beginning at the lowest frequency, are placed in a running sum until 0.5 % of the total is reached; that frequency is recorded as the lower frequency. The process is repeated until 99.5 % of the total is reached; that frequency is recorded as the upper frequency. The 99% occupied bandwidth is the difference between these two frequencies.

9.4 EUT operating Conditions

The EUT was configured for testing in a typical fashion (as a customer would normally use it). The EUT has been programmed to continuously transmit during test. This operating condition was tested and used to collect the included data.

9.5 Test Result

Temperature:	26 °C	Relative Humidity:	54%
Pressure:	101KPa	Test Voltage:	DC 12V
Test Mode:	(5180-5240MHz)		

Condition	Mode	Frequency (MHz)	99% bandwidth (MHz)	-26dB bandwidth (MHz)	Result
NVNT	a	5180	16.578	21.342	Pass
NVNT	a	5200	16.557	21.224	Pass
NVNT	a	5240	16.56	21.516	Pass
NVNT	n20	5180	17.718	21.637	Pass
NVNT	n20	5200	17.725	21.616	Pass
NVNT	n20	5240	17.728	21.525	Pass
NVNT	n40	5190	36.076	40.513	Pass
NVNT	n40	5230	36.231	40.588	Pass
NVNT	ac20	5180	17.7	21.656	Pass
NVNT	ac20	5200	17.744	21.562	Pass
NVNT	ac20	5240	17.739	21.365	Pass
NVNT	ac40	5190	36.156	40.263	Pass
NVNT	ac40	5230	36.251	40.158	Pass
NVNT	ac80	5210	75.61	81.837	Pass

TEST
 TO
 OVER
 检

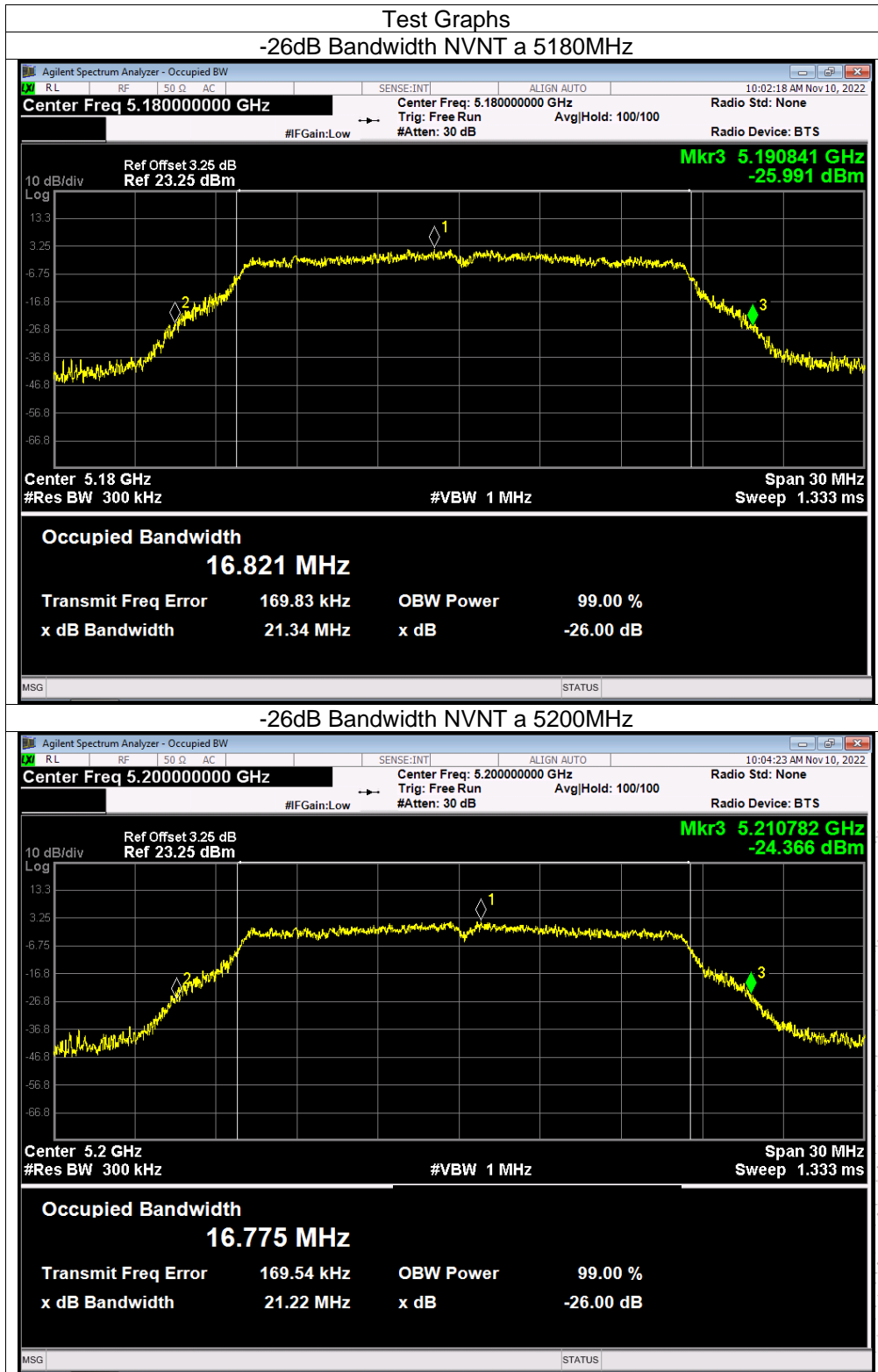

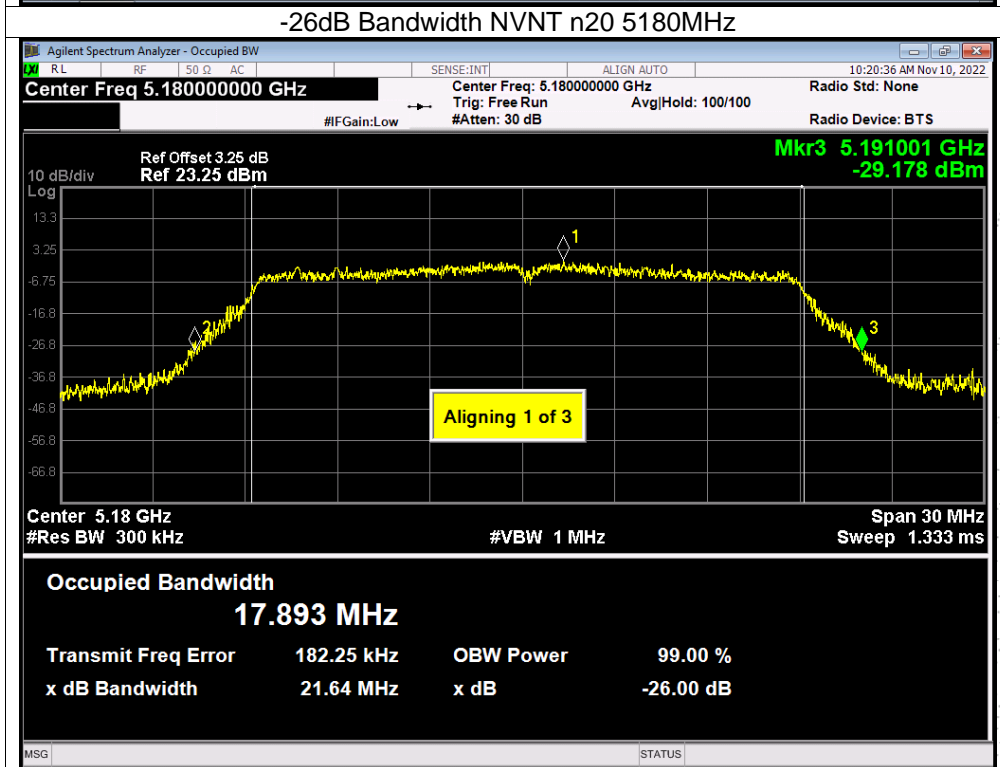
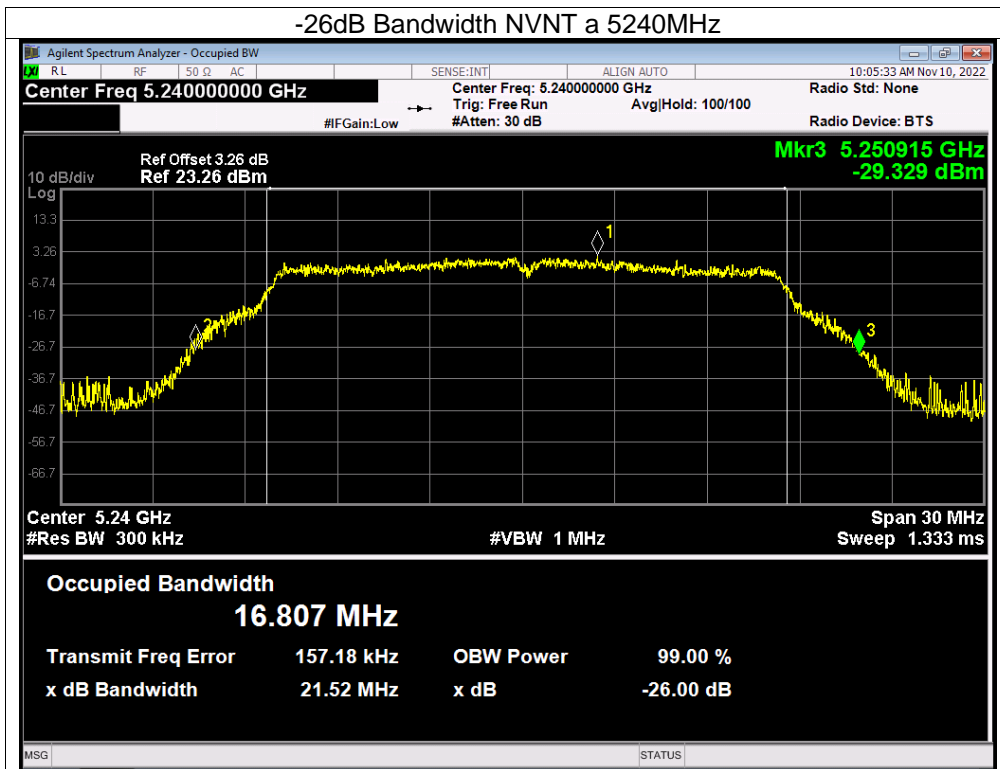

CO.LTD

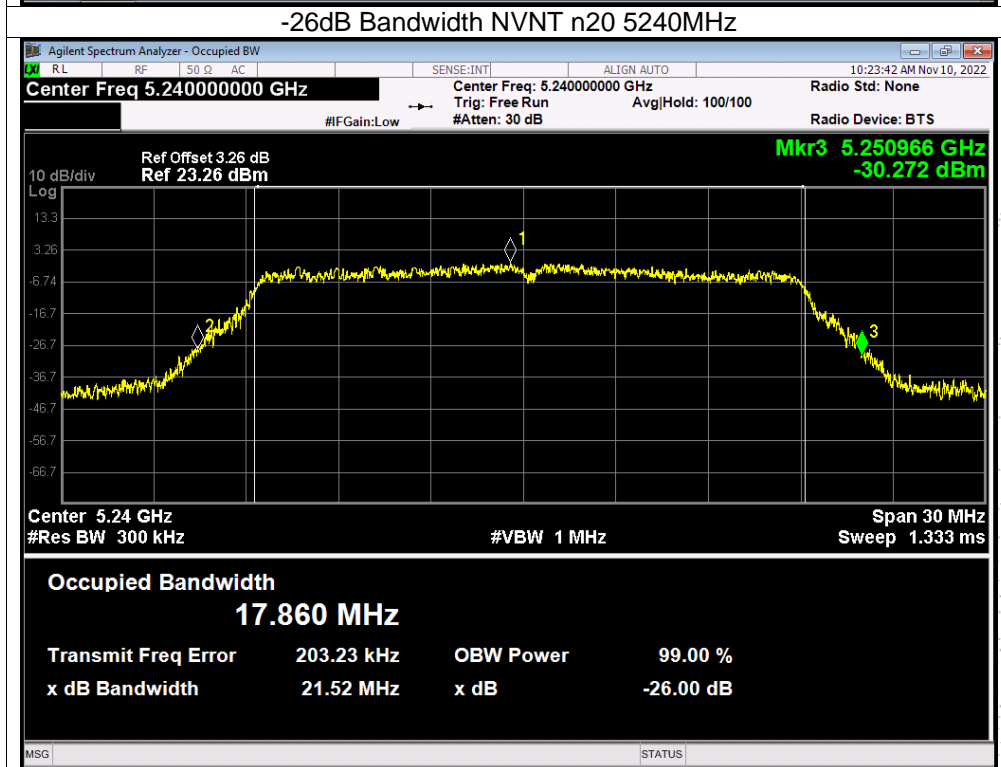
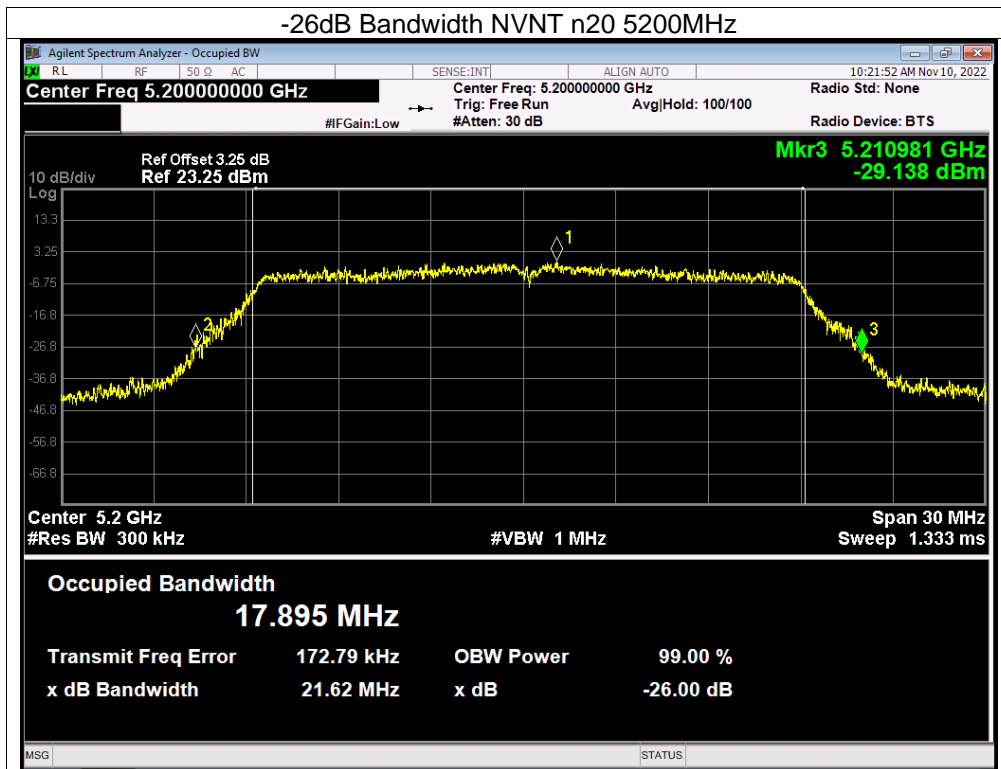

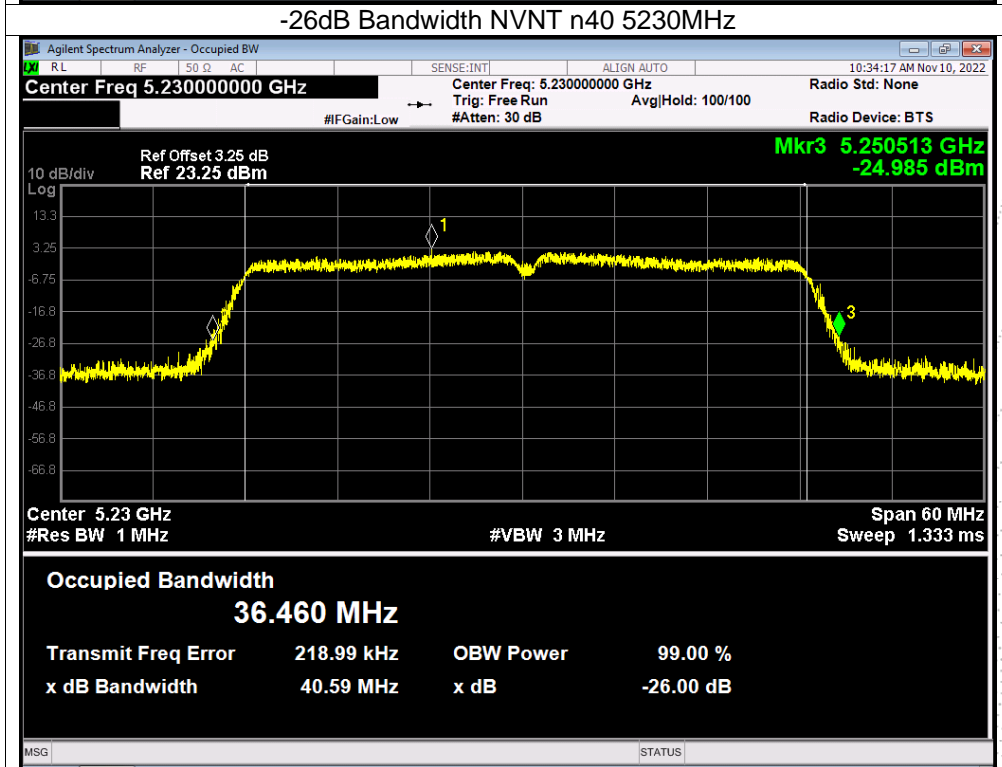
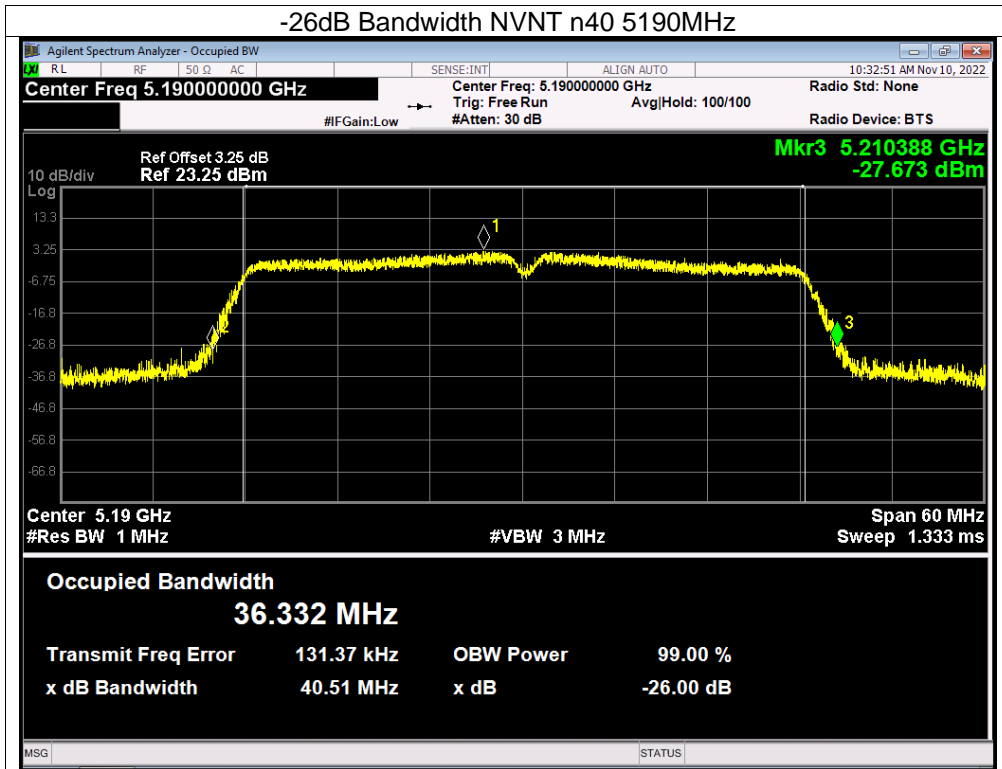

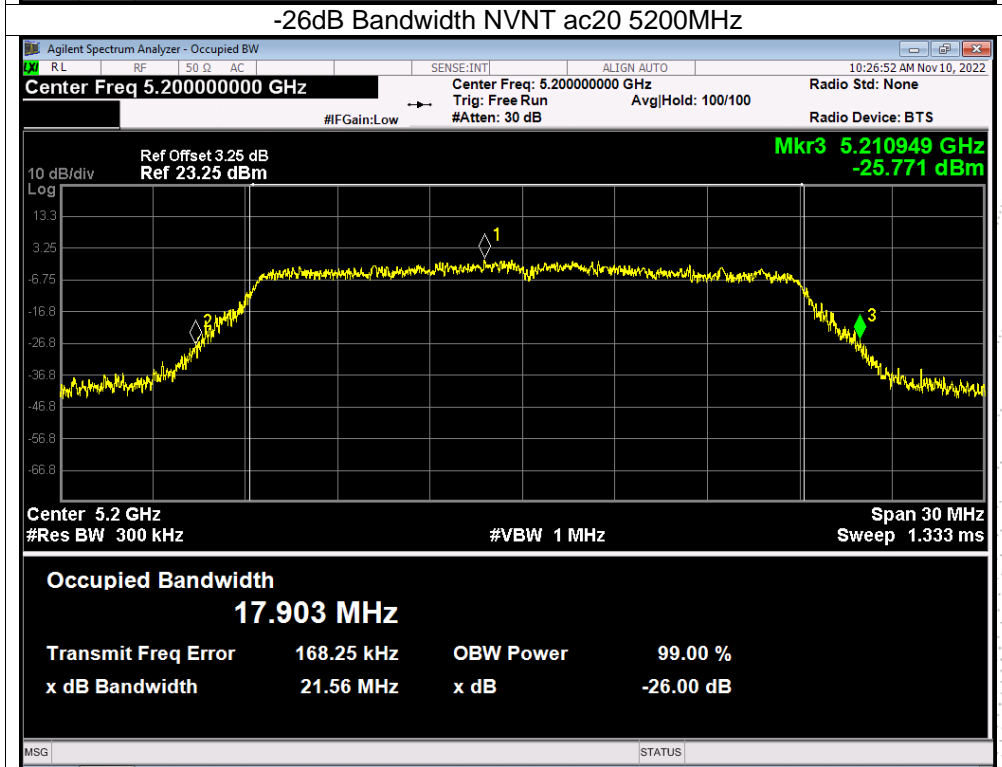
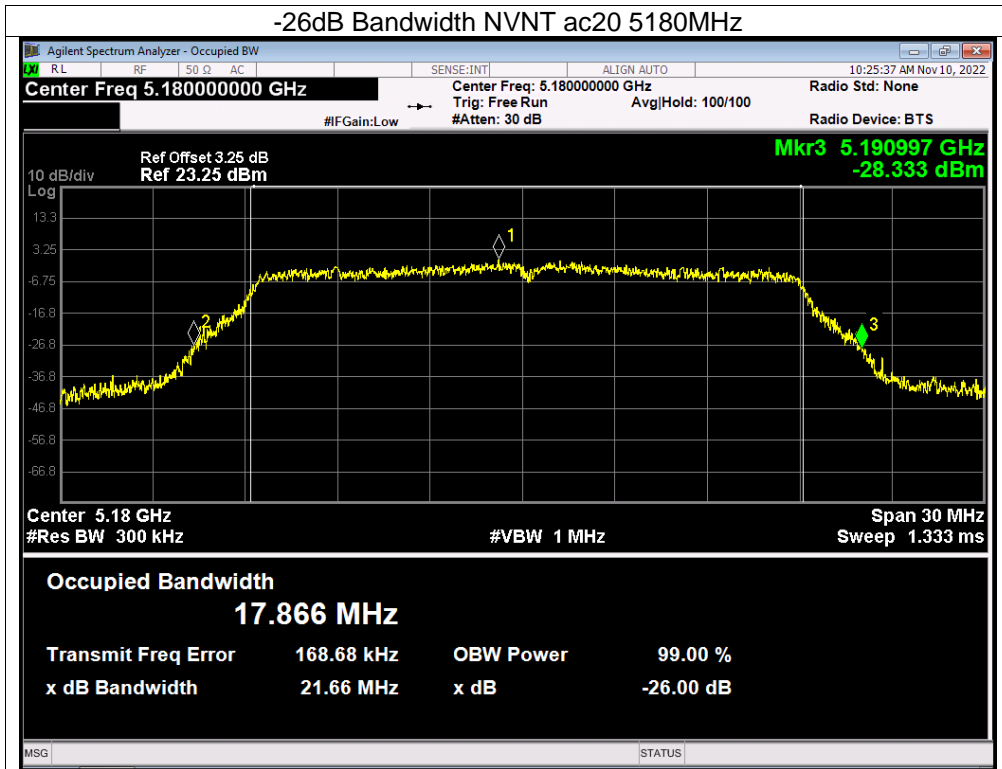

TC
 3C
 PPR
 检测

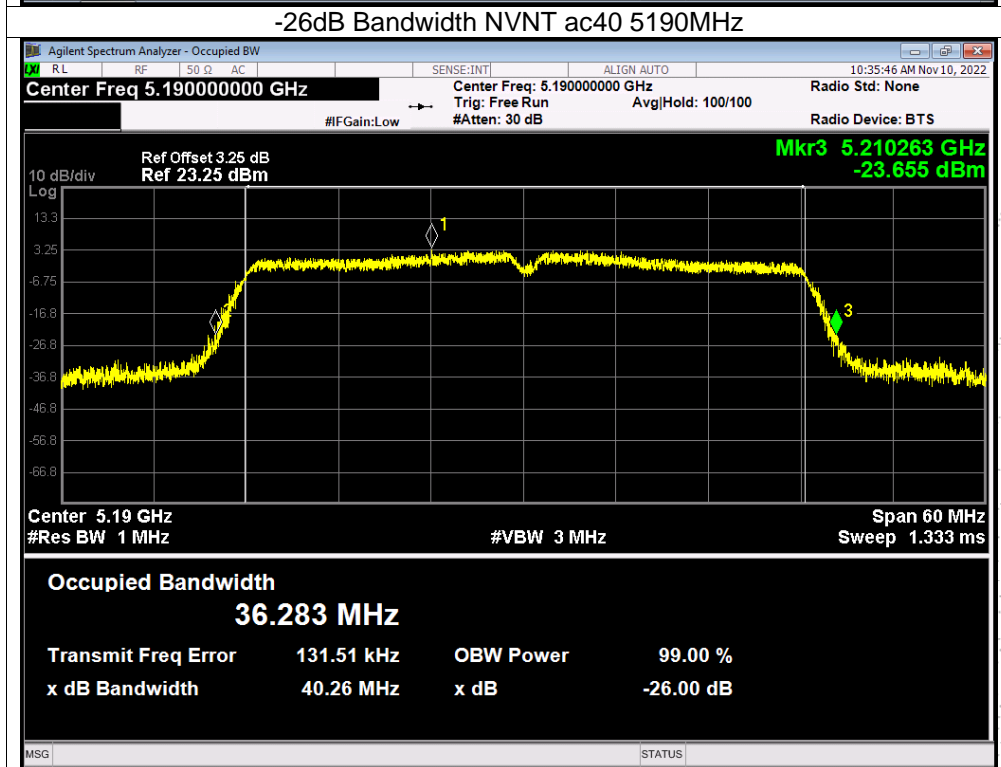
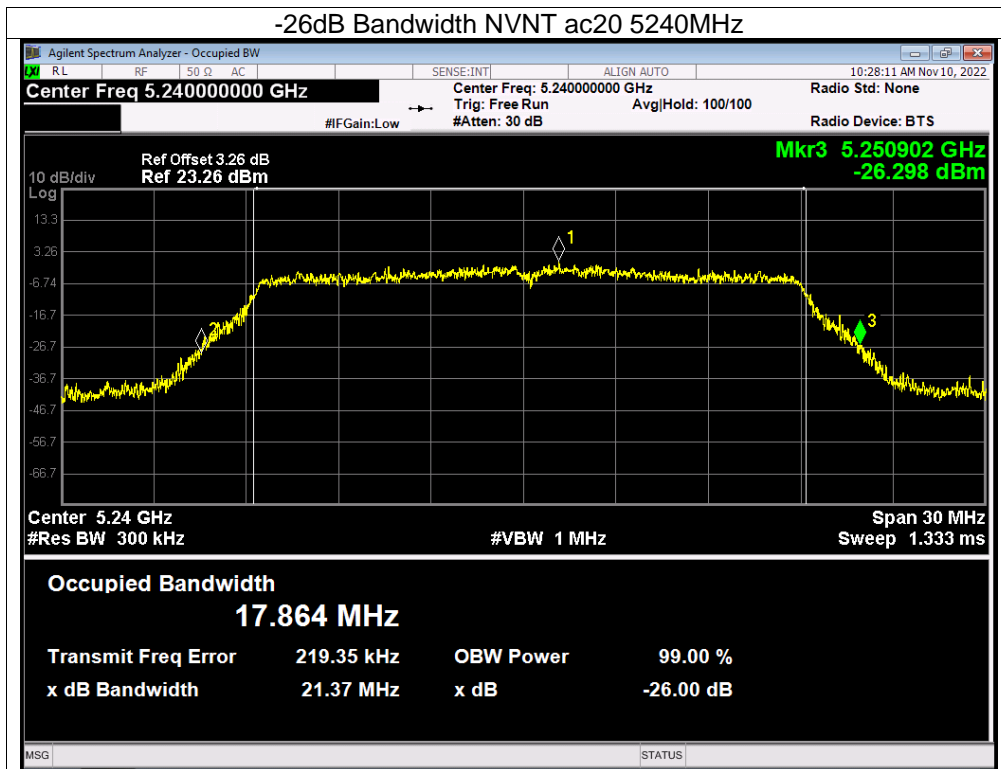

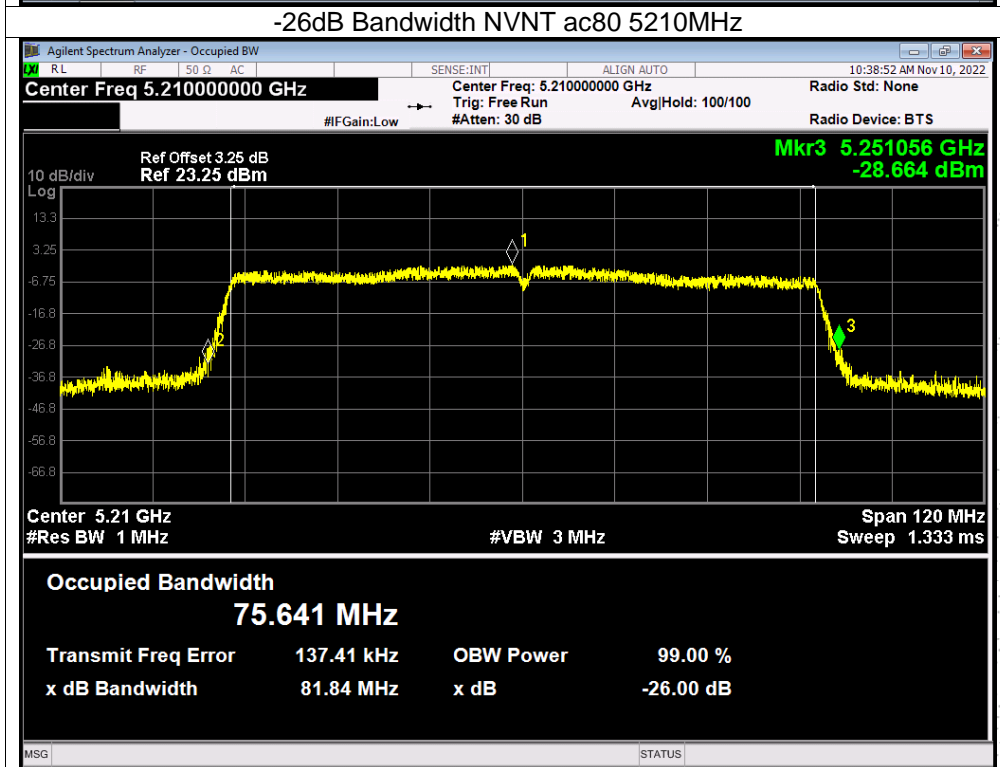
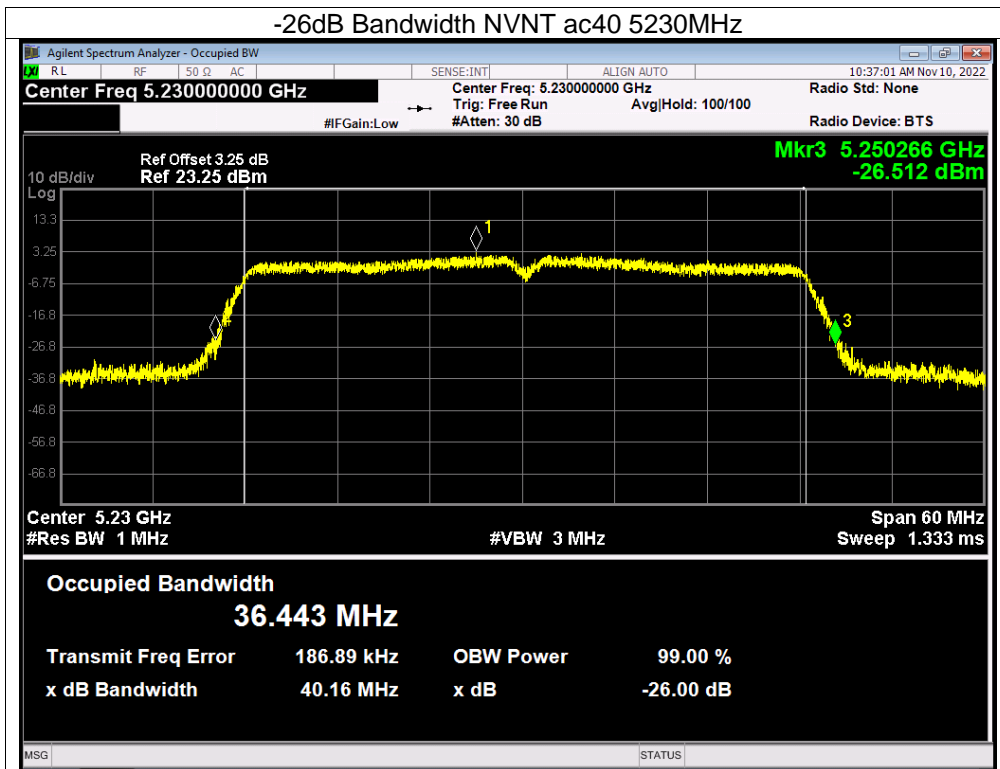

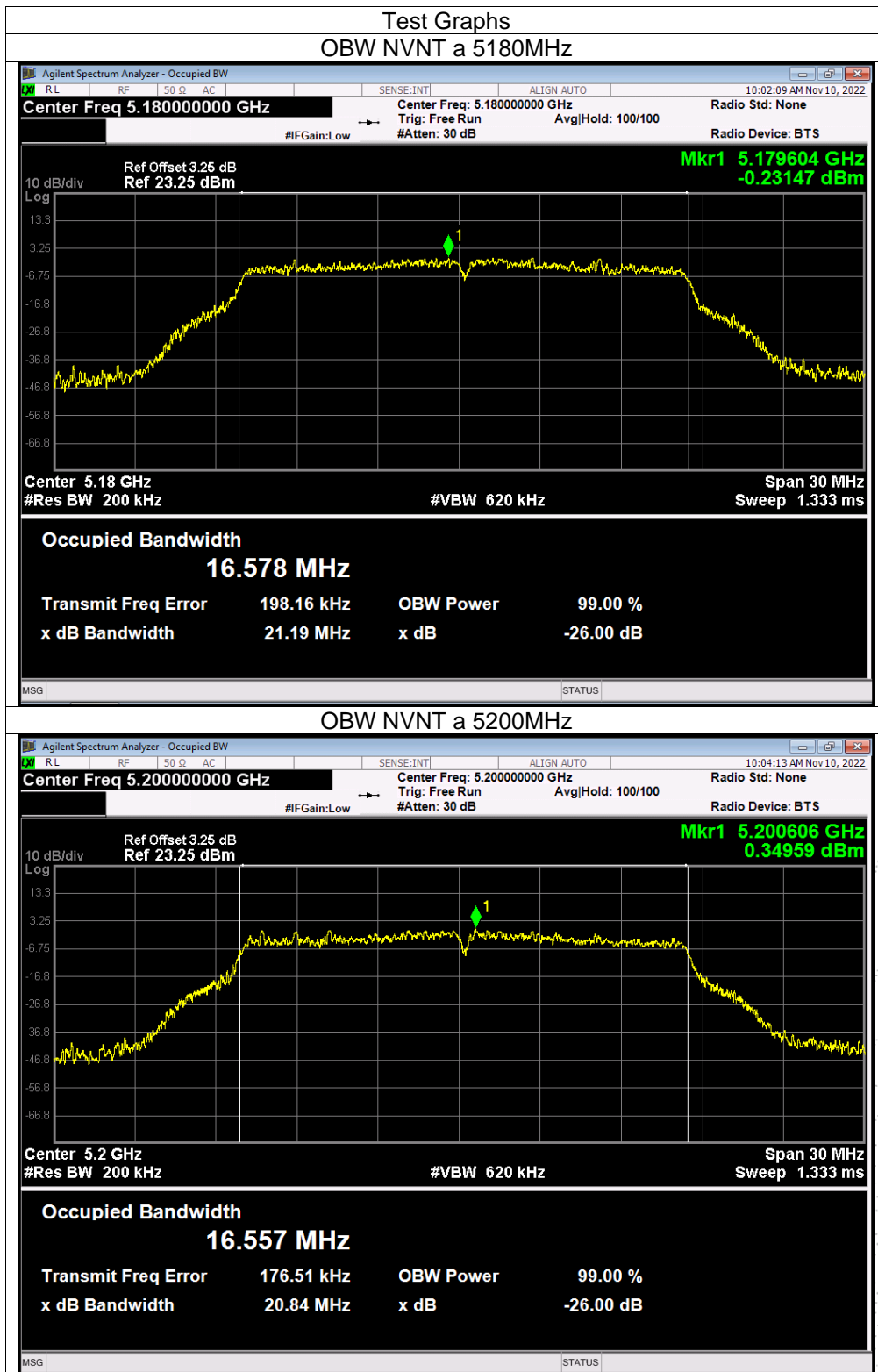

CO., LTD

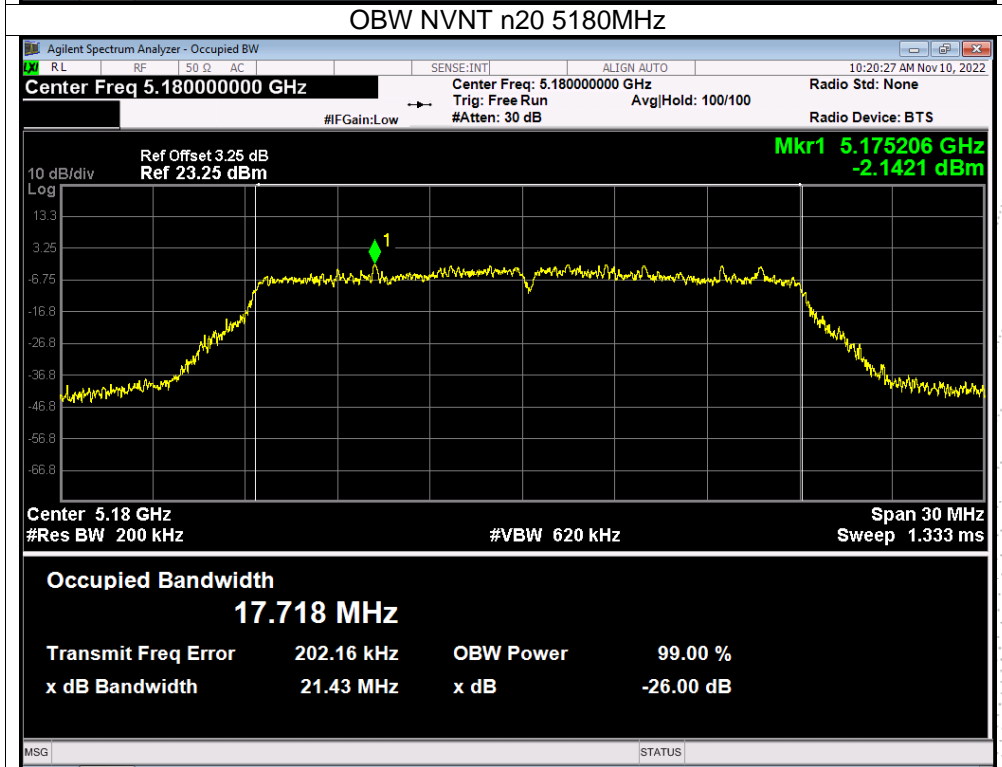
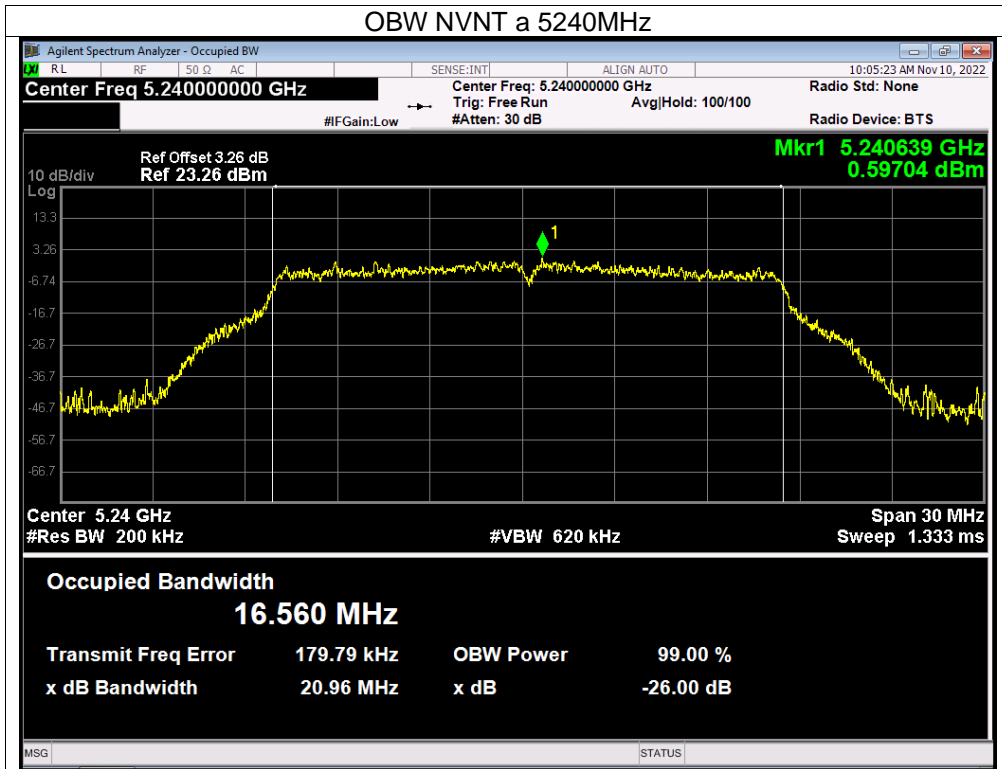

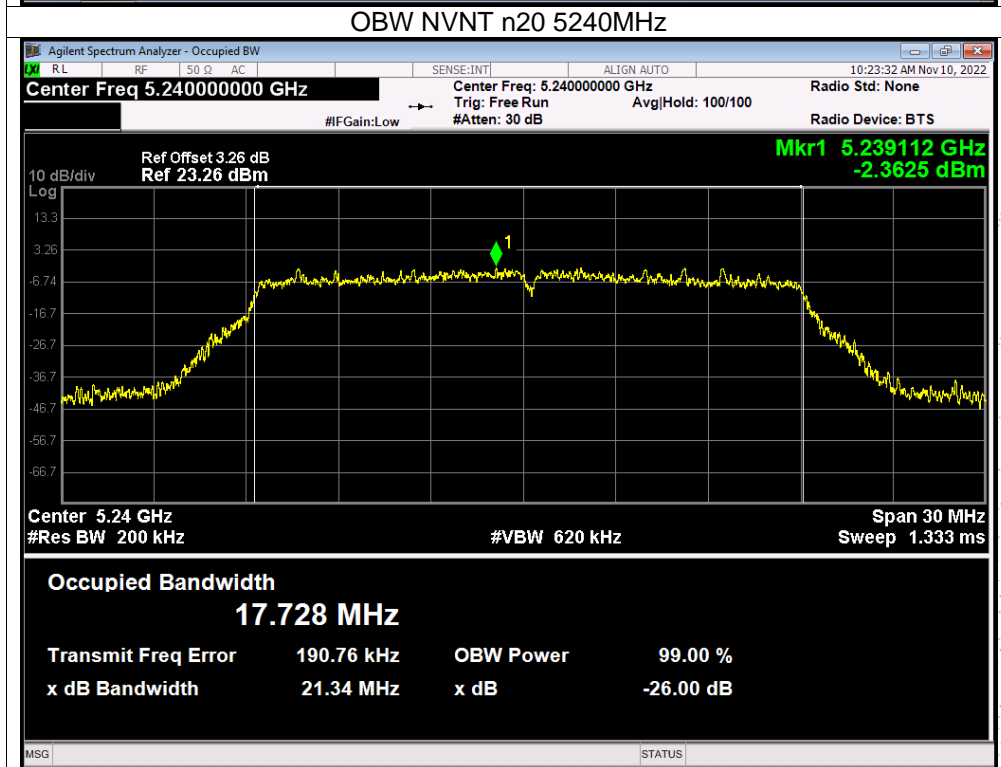
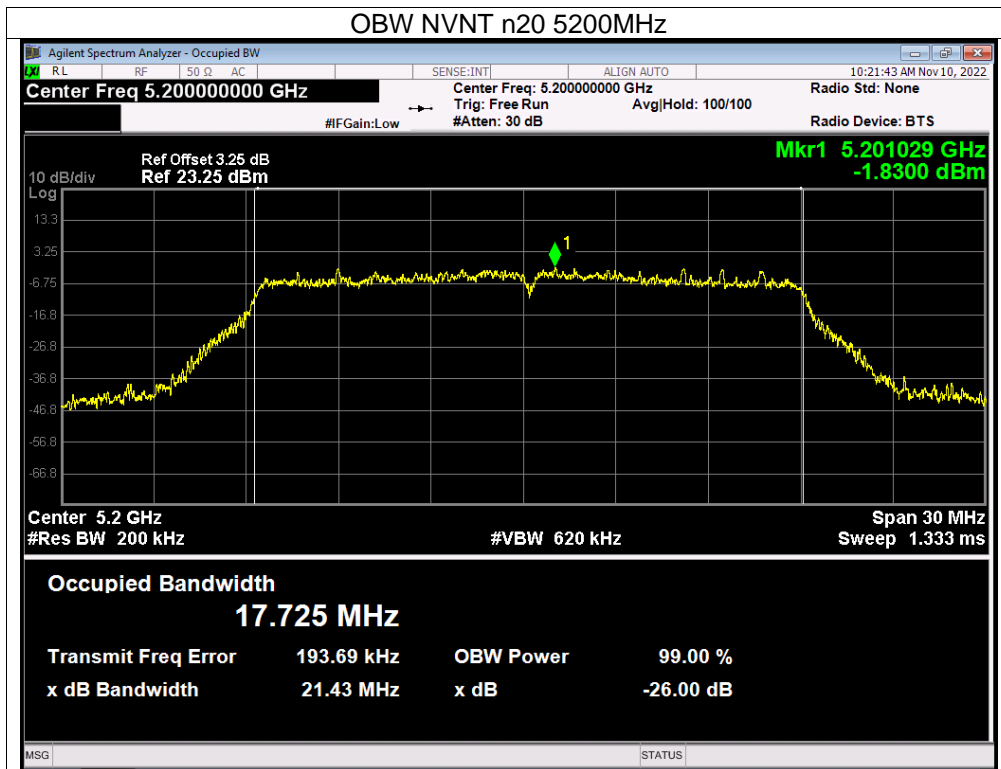

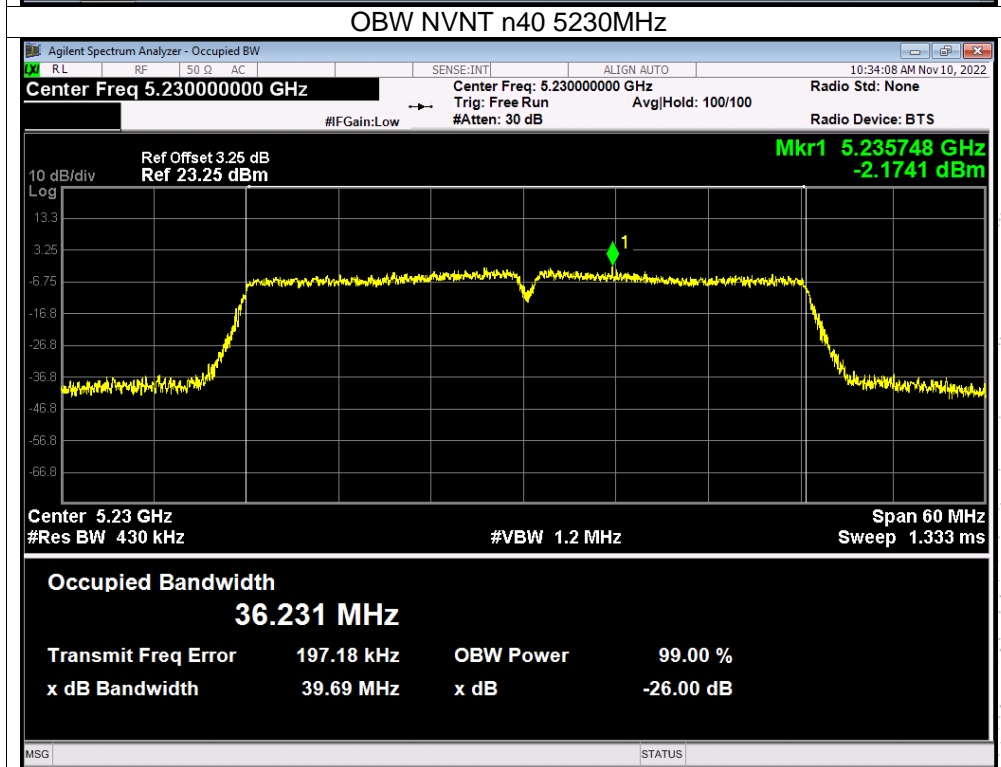
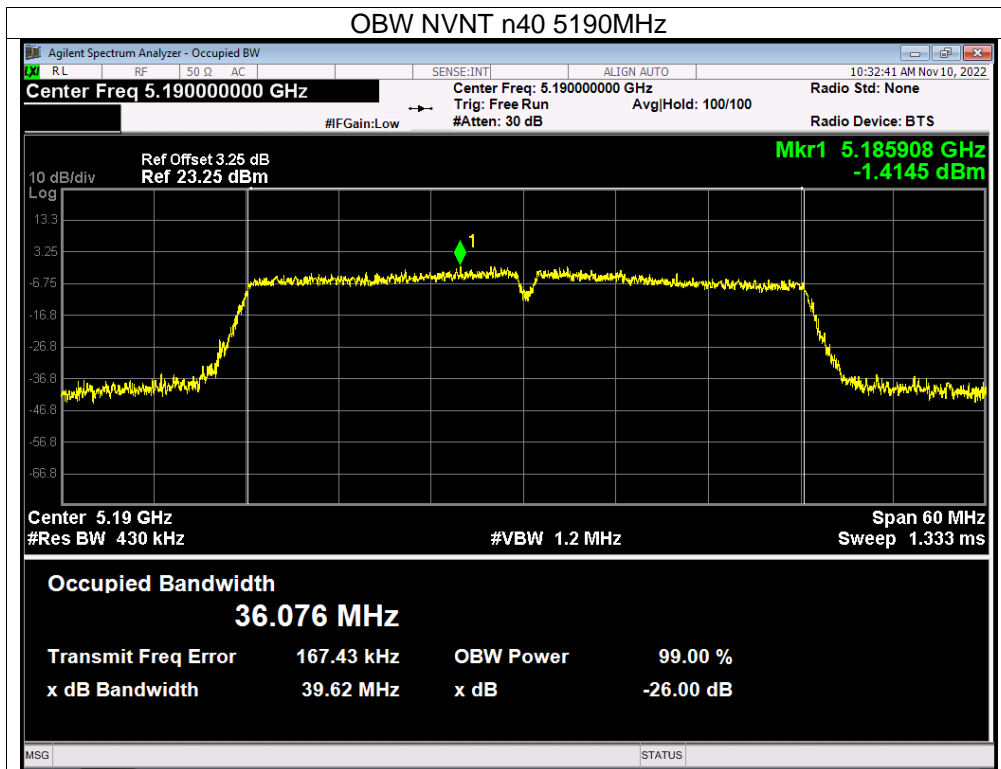

BCTC
 BCTC
 PPR
 检测

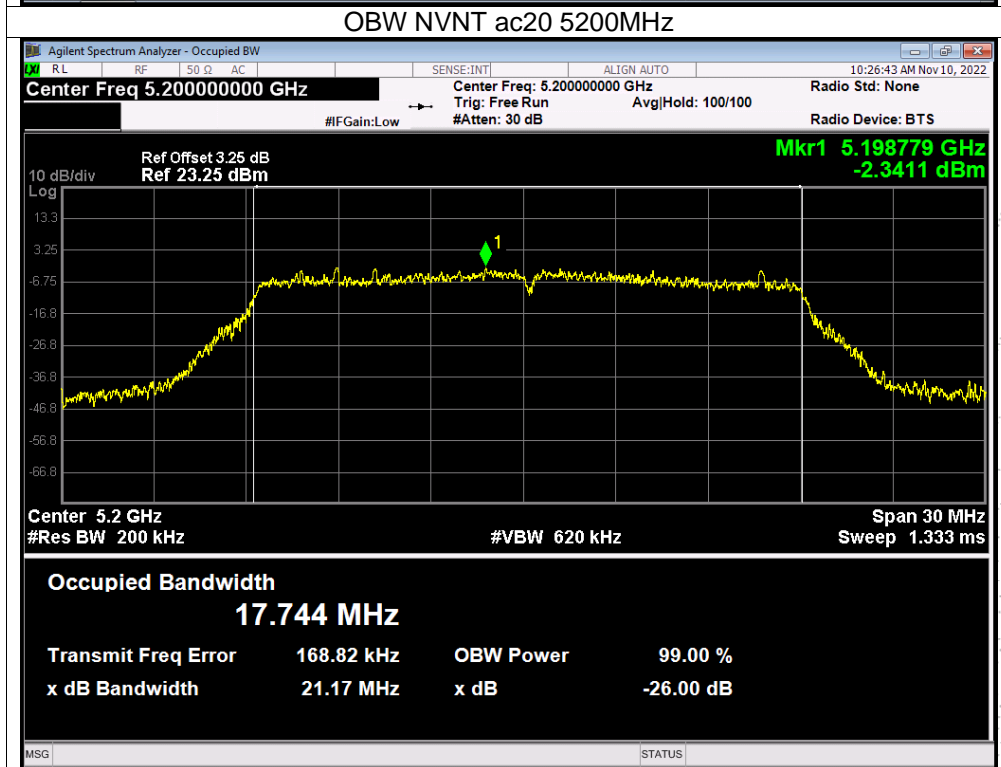
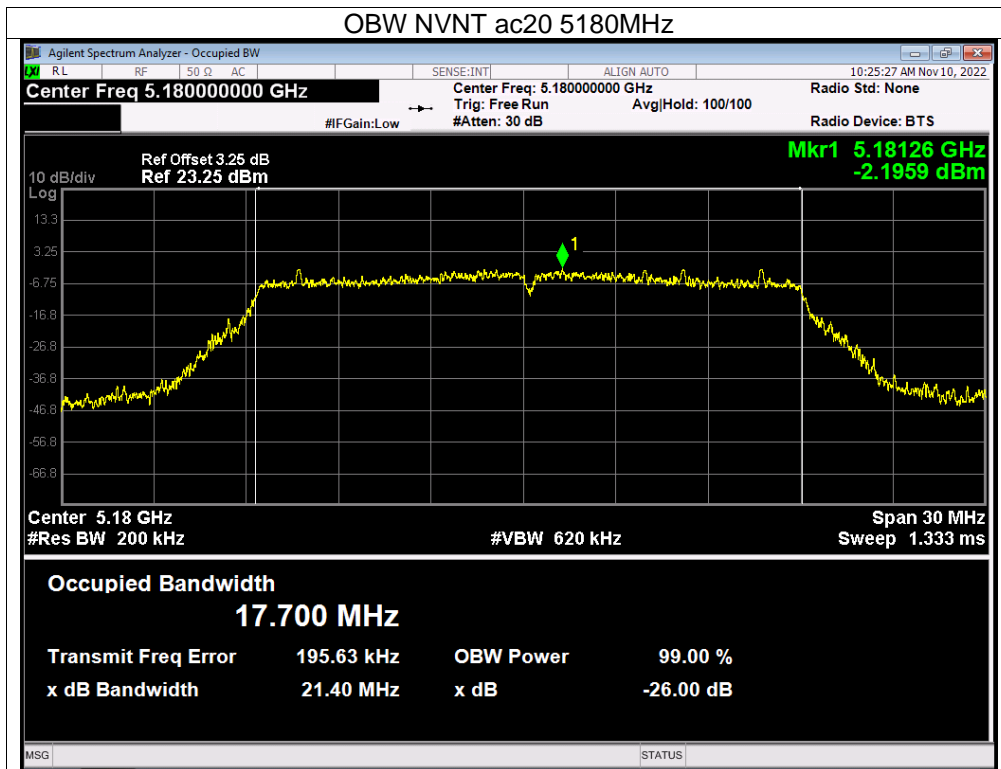

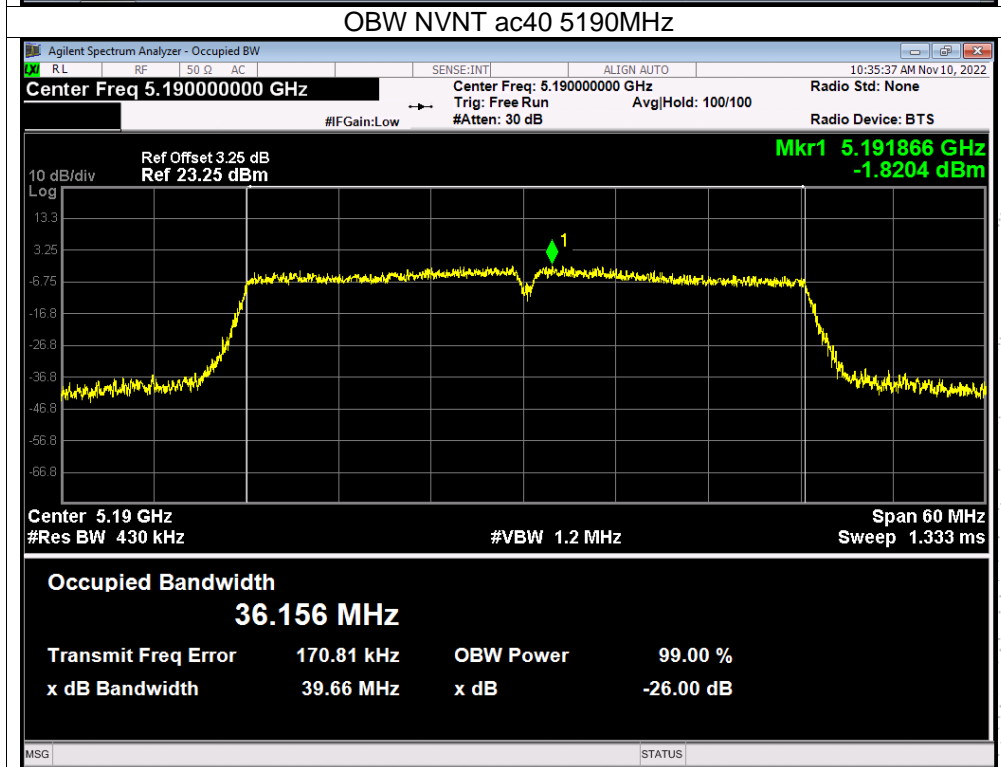
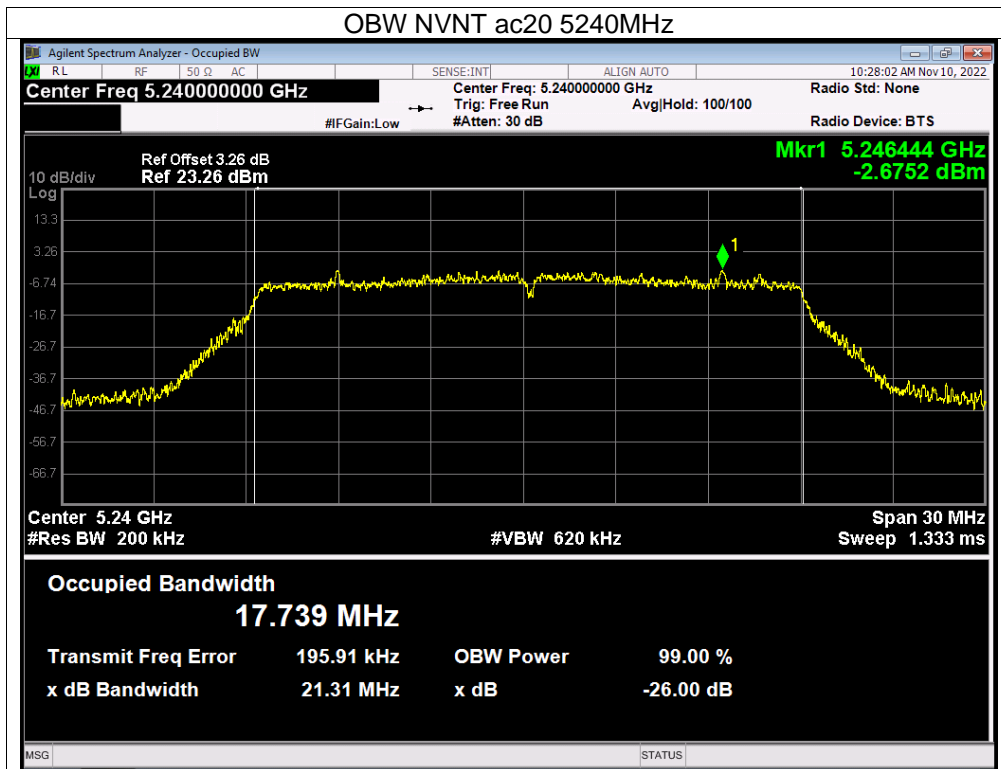

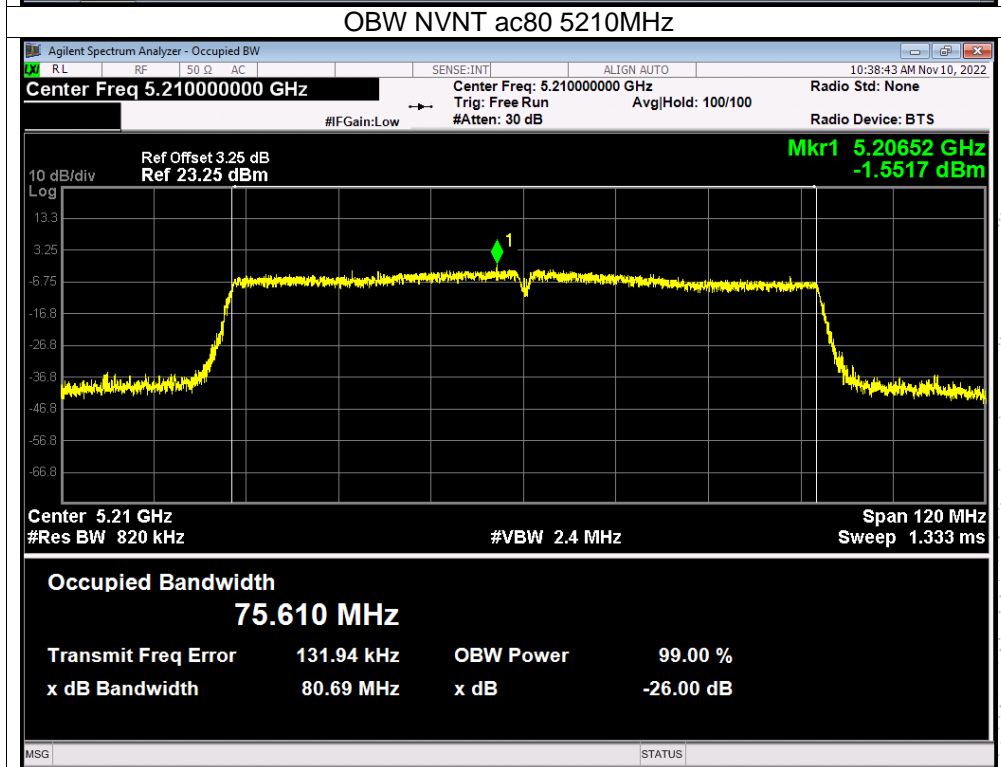
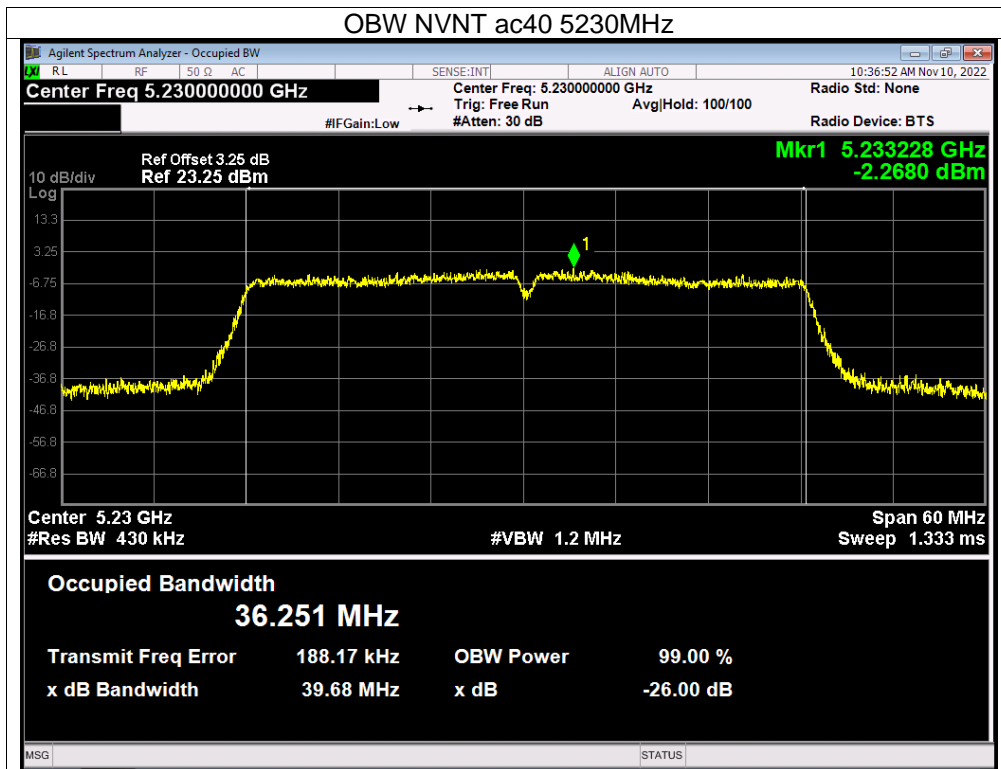

CO., LTD

10. Maximum Conducted Output Power

10.1 Block Diagram Of Test Setup

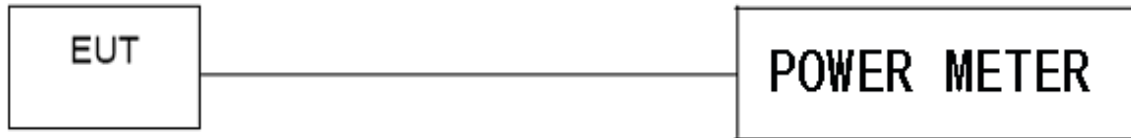

10.2 Limit

According to RSS-247 Issue 2 section 6.2, Power and unwanted emissions limits as below:

Section 6.2.1.1 For frequency band 5150-5250 MHz, For OEM devices installed in vehicles, the maximum e.i.r.p. shall not exceed 30 mW or $1.76 + 10 \log_{10} B$, dBm, whichever is less stringent. Devices shall implement transmitter power control (TPC) in order to have the capability to operate at least 3 dB below the maximum permitted e.i.r.p. of 30 mW.

For other devices, the maximum e.i.r.p. shall not exceed 200 mW or $10 + 10 \log_{10} B$, dBm, whichever power is less. B is the 99% emission bandwidth in megahertz. The e.i.r.p. spectral density shall not exceed 10 dBm in any 1.0 MHz band.

Section 6.2.2.1 For Frequency band 5250-5350 MHz, For OEM devices installed in vehicles, the maximum e.i.r.p. shall not exceed 30 mW or $1.76 + 10 \log_{10} B$, dBm, whichever is less. Devices shall implement TPC in order to have the capability to operate at least 3 dB below the maximum permitted e.i.r.p. of 30 mW.

Devices, other than devices installed in vehicles, shall comply with the following:

a) The maximum conducted output power shall not exceed 250 mW or $11 + 10 \log_{10} B$, dBm, whichever is less. The power spectral density shall not exceed 11 dBm in any 1.0 MHz band;

b) The maximum e.i.r.p. shall not exceed 1.0 W or $17 + 10 \log_{10} B$, dBm, whichever is less. B is the 99% emission bandwidth in megahertz. Note that devices with a maximum e.i.r.p. greater than 500 mW shall implement TPC in order to have the capability to operate at least 6 dB below the maximum permitted e.i.r.p. of 1 W.

Section 6.2.3.1 For Frequency bands 5470-5600 MHz and 5650-5725 MHz, The maximum conducted output power shall not exceed 250 mW or $11 + 10 \log_{10} B$, dBm, whichever is less. The power spectral density shall not exceed 11 dBm in any 1.0 MHz band.

The maximum e.i.r.p. shall not exceed 1.0 W or $17 + 10 \log_{10} B$, dBm, whichever is less. B is the 99% emission bandwidth in megahertz. Note that devices with a maximum e.i.r.p. greater than 500 mW shall implement TPC in order to have the capability to operate at least 6 dB below the maximum permitted e.i.r.p. of 1 W.

Section 6.2.4.1 For Frequency band 5725-5850 MHz, For equipment operating in the band 5725-5850 MHz, the minimum 6 dB bandwidth shall be at least 500 kHz.

The maximum conducted output power shall not exceed 1 W. The output power spectral density shall not exceed 30 dBm in any 500 kHz band. If transmitting antennas of directional gain greater than 6 dBi are used, both the maximum conducted output power and the output power spectral density shall be reduced by the amount in dB that the directional gain of the antenna exceeds 6 dBi. However, fixed point-to-point devices operating in this band may employ transmitting antennas with directional gain greater than 6 dBi without any corresponding reduction in transmitter conducted power. Fixed point-to-point operations exclude the use of point-to-multipoint systems, omnidirectional applications and multiple collocated transmitters transmitting the same information.

10.3 Test procedure

The EUT was directly connected to the Power meter

10.4 EUT operating Conditions

The EUT was configured for testing in a typical fashion (as a customer would normally use it). The EUT has been programmed to continuously transmit during test. This operating condition was tested and used to collect the included data.

10.5 Test Result

Temperature:	26 °C	Relative Humidity:	54%
Pressure:	101KPa	Test Voltage:	DC 12V
Test Mode:	5180-5240MHz		

Condition	Mode	Frequency (MHz)	Conducted Power (dBm)	EIRP	Limit (dBm)	Verdict
NVNT	a	5180	9.73	13.83	22	Pass
NVNT	a	5200	9.77	13.87	22	Pass
NVNT	a	5240	9.77	13.87	22	Pass
NVNT	n20	5180	7.95	12.05	22	Pass
NVNT	n20	5200	8	12.10	22	Pass
NVNT	n20	5240	7.69	11.79	22	Pass
NVNT	n40	5190	6.93	11.03	23	Pass
NVNT	n40	5230	7.29	11.39	23	Pass
NVNT	ac20	5180	7.82	11.92	22	Pass
NVNT	ac20	5200	7.48	11.58	22	Pass
NVNT	ac20	5240	7.25	11.35	22	Pass
NVNT	ac40	5190	7.31	11.41	23	Pass
NVNT	ac40	5230	7.21	11.31	23	Pass
NVNT	ac80	5210	6.43	10.53	23	Pass

Note: EIRP= Output Power+Antenna Gain, Antenna Gain=4.1 dBi

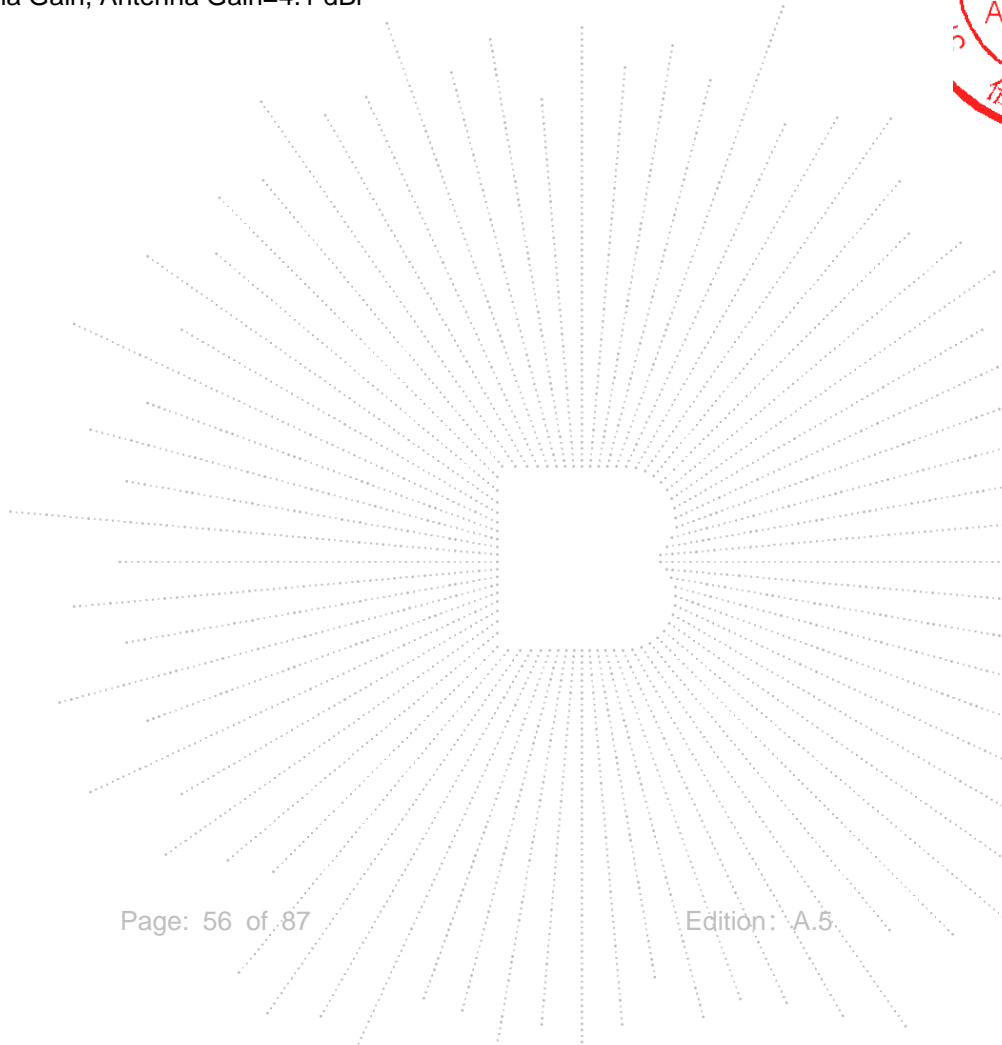

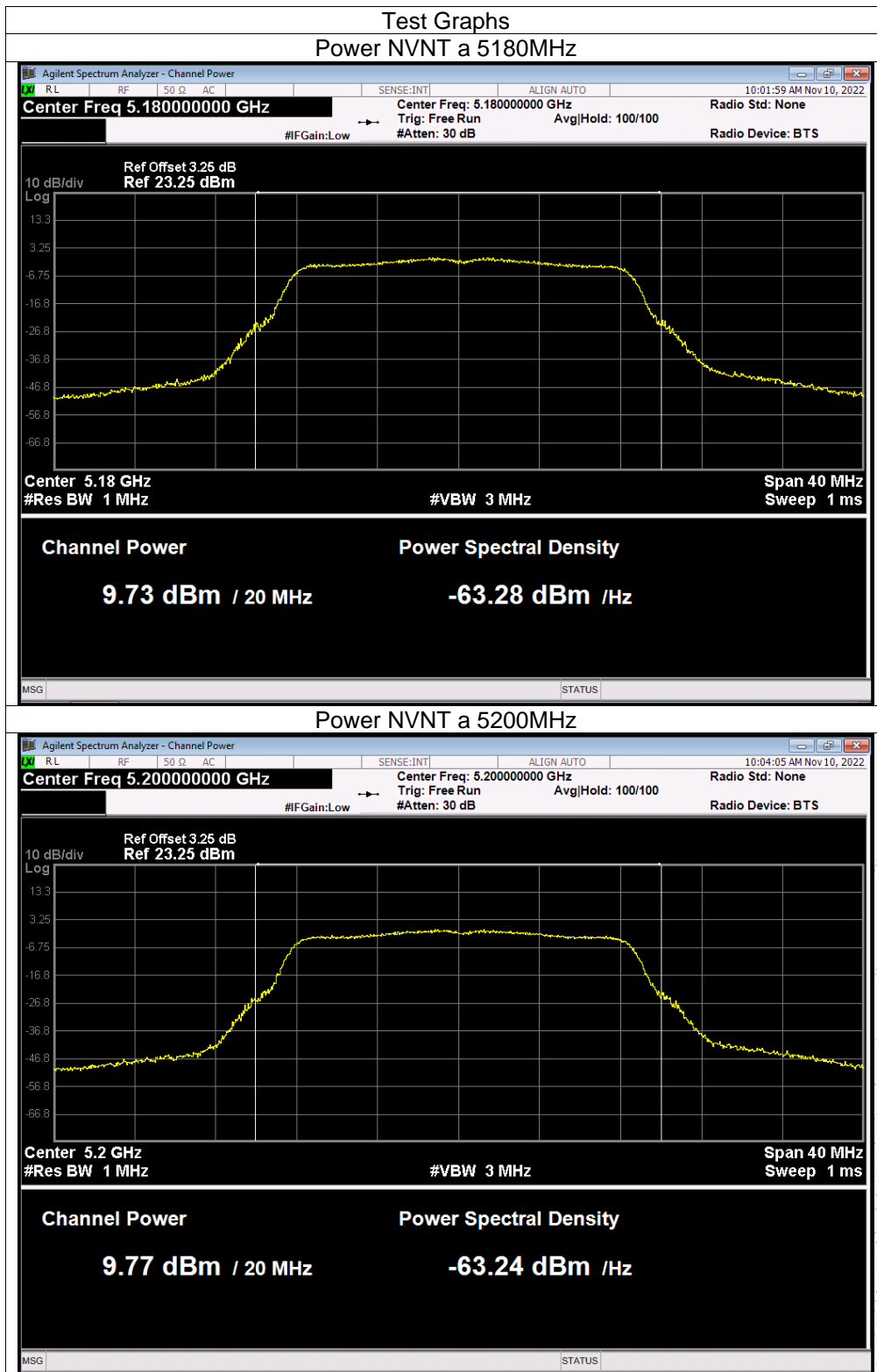

TC
3C
PPR
測

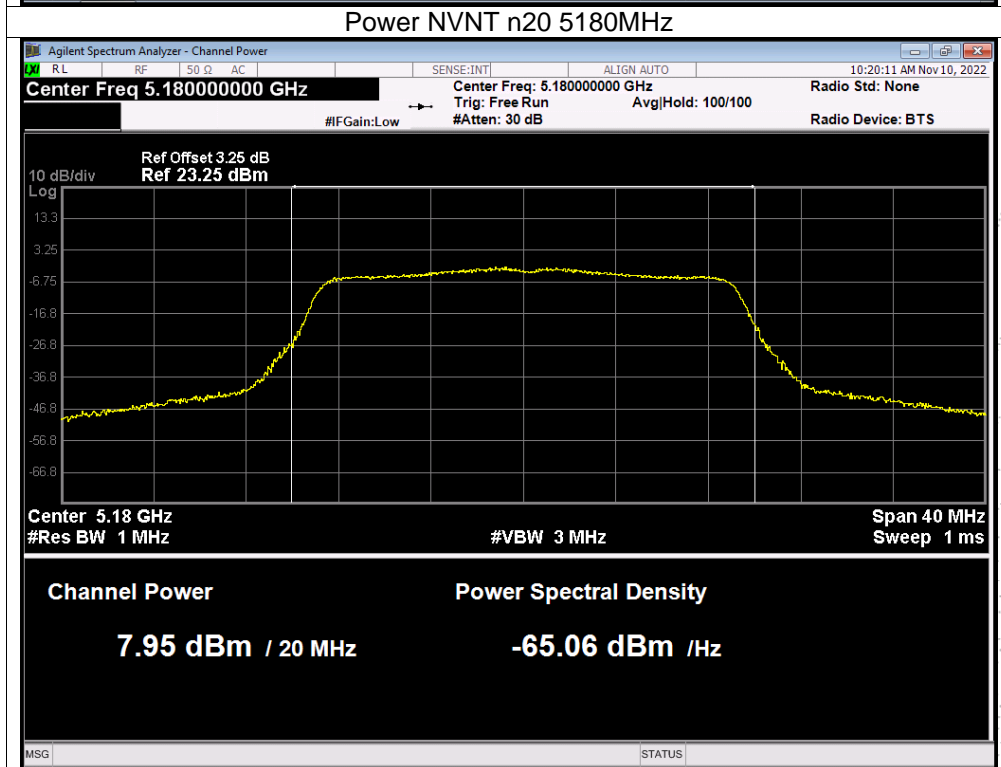
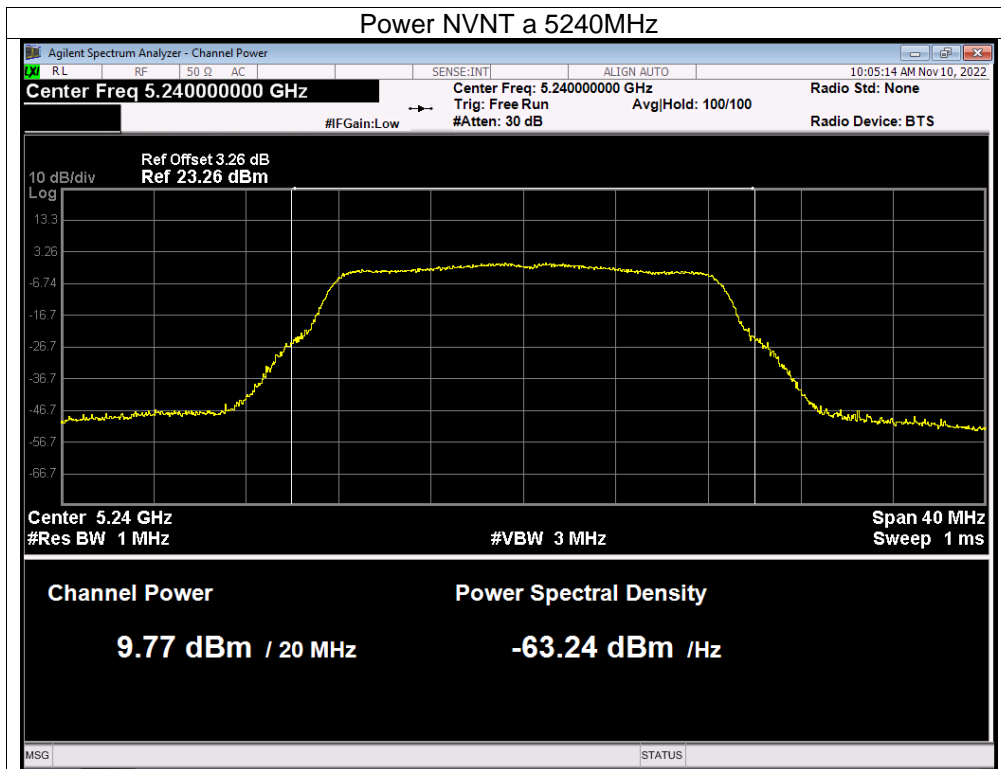

檢
 驗
 通
 過
 認
 可

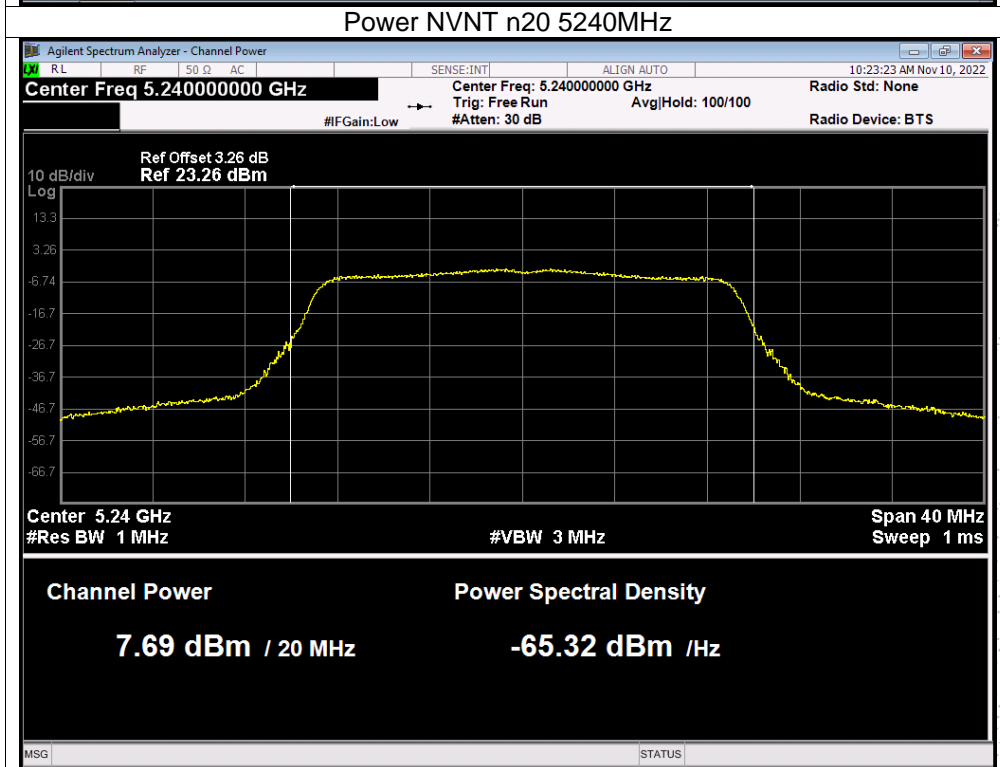
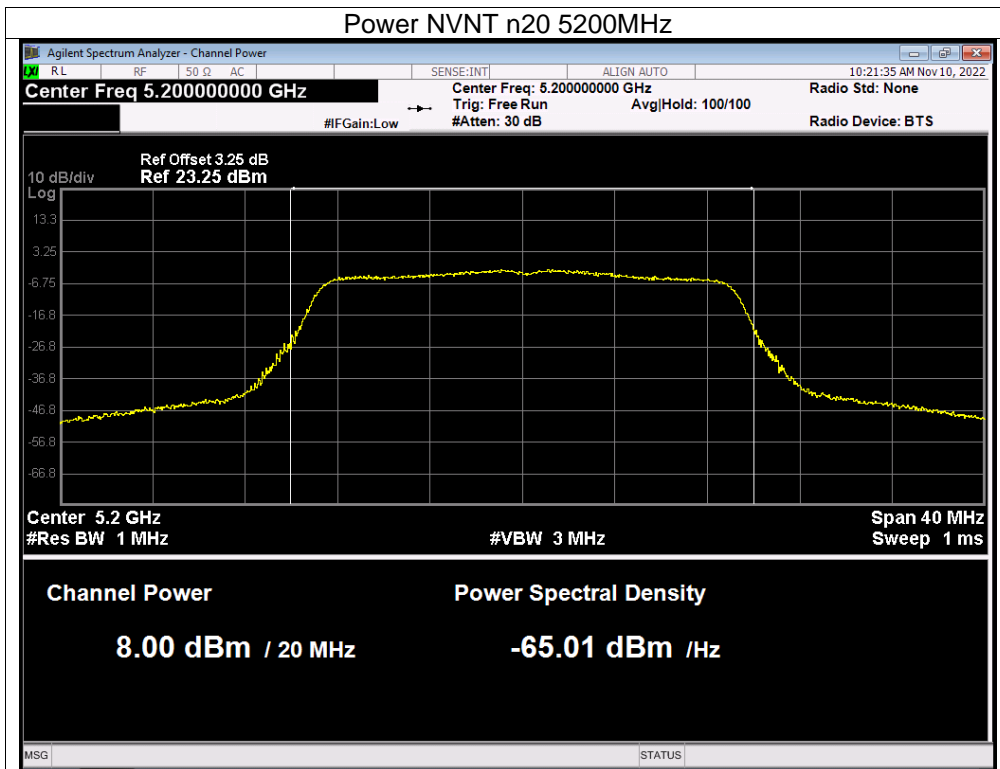

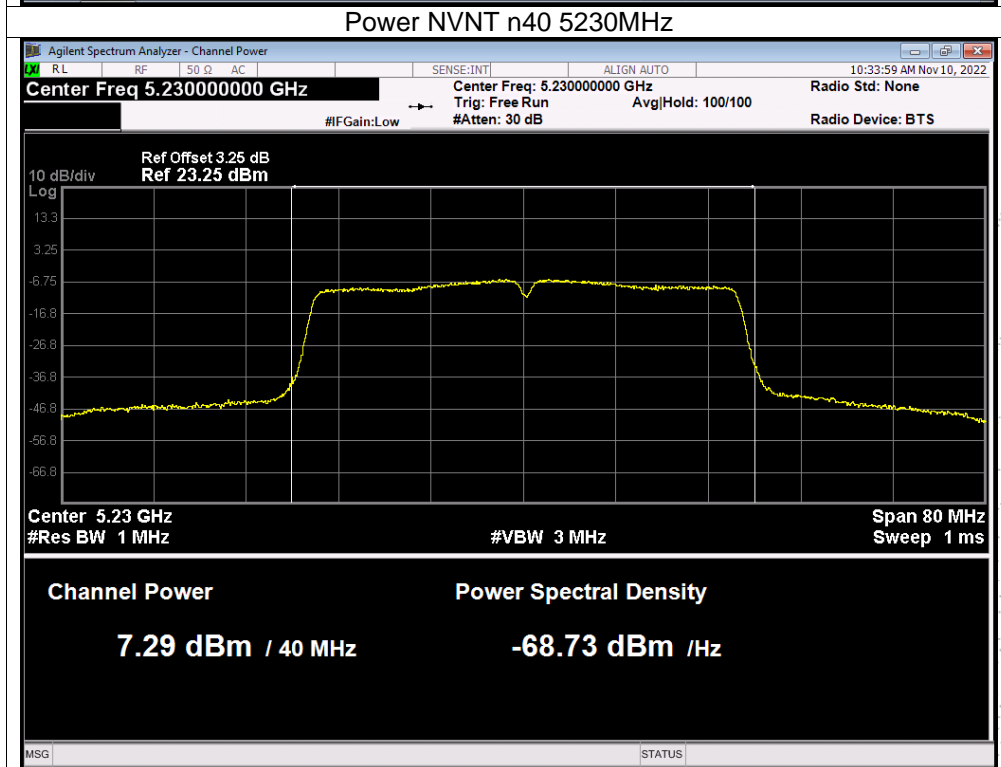
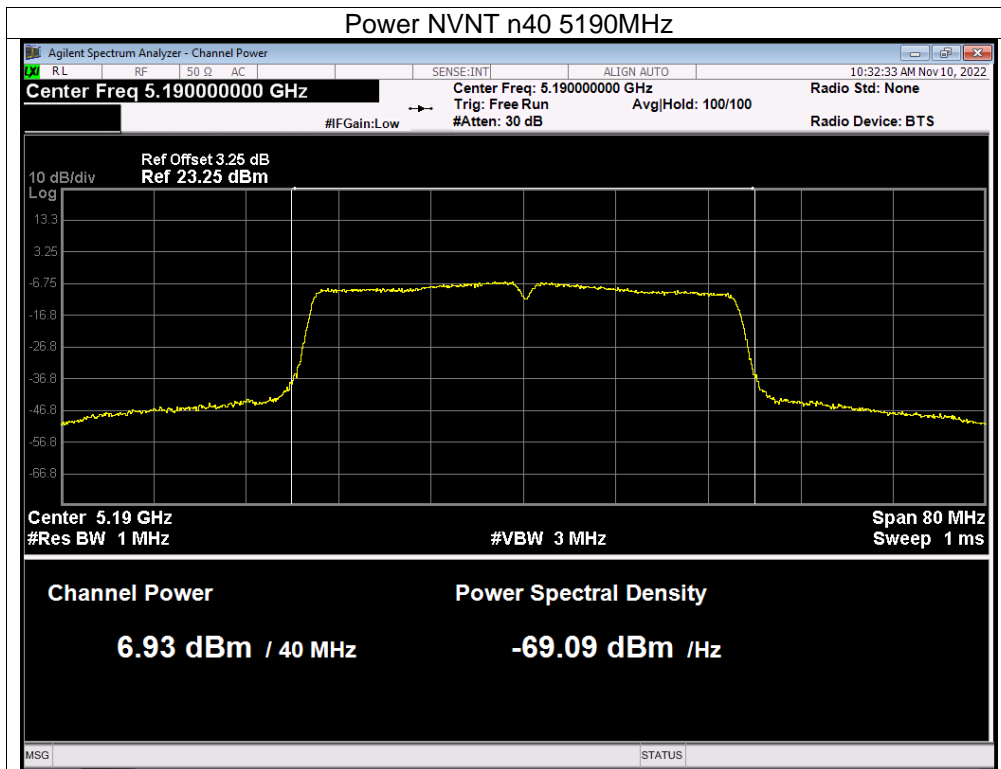

CO., LTD

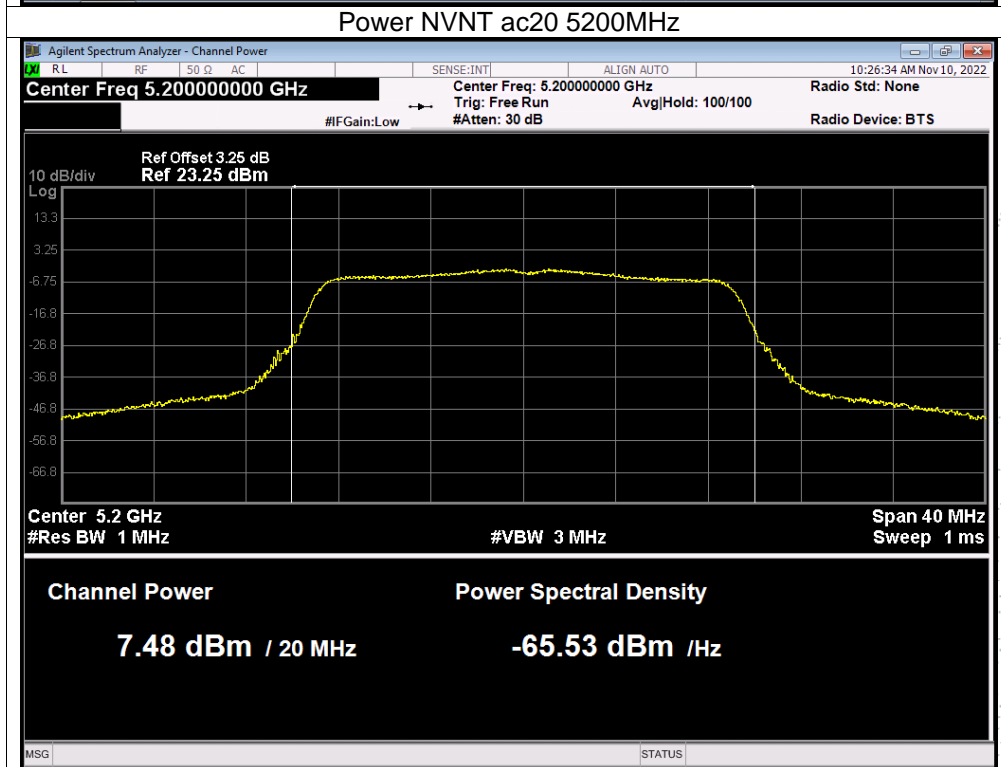
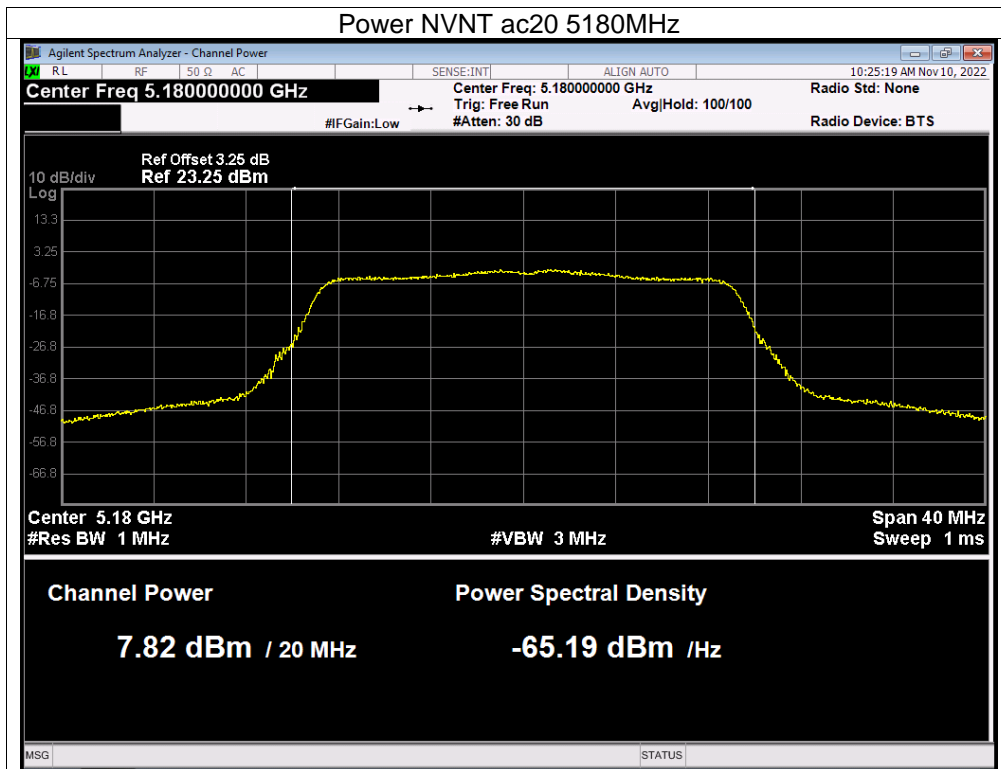

SHENZHEN

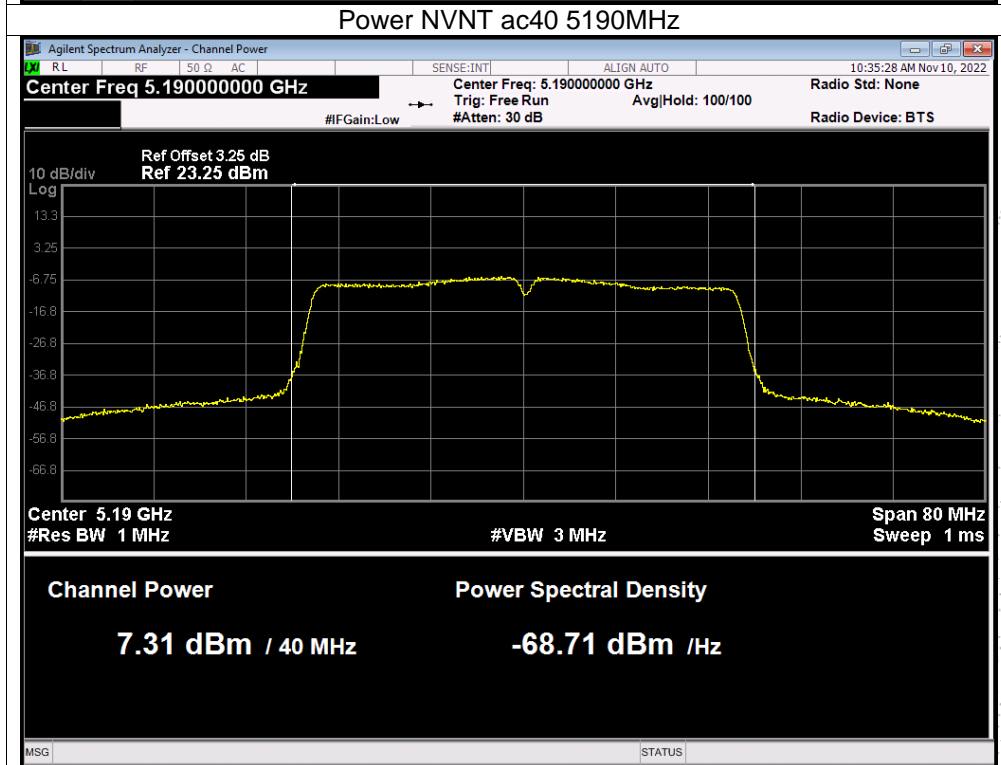
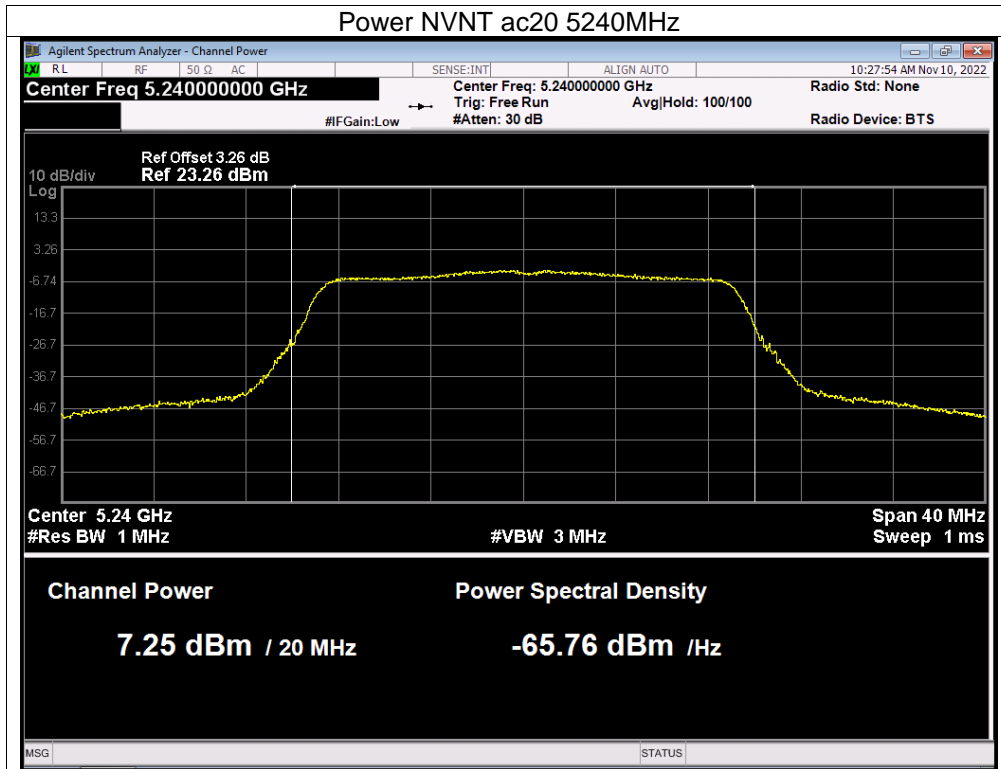

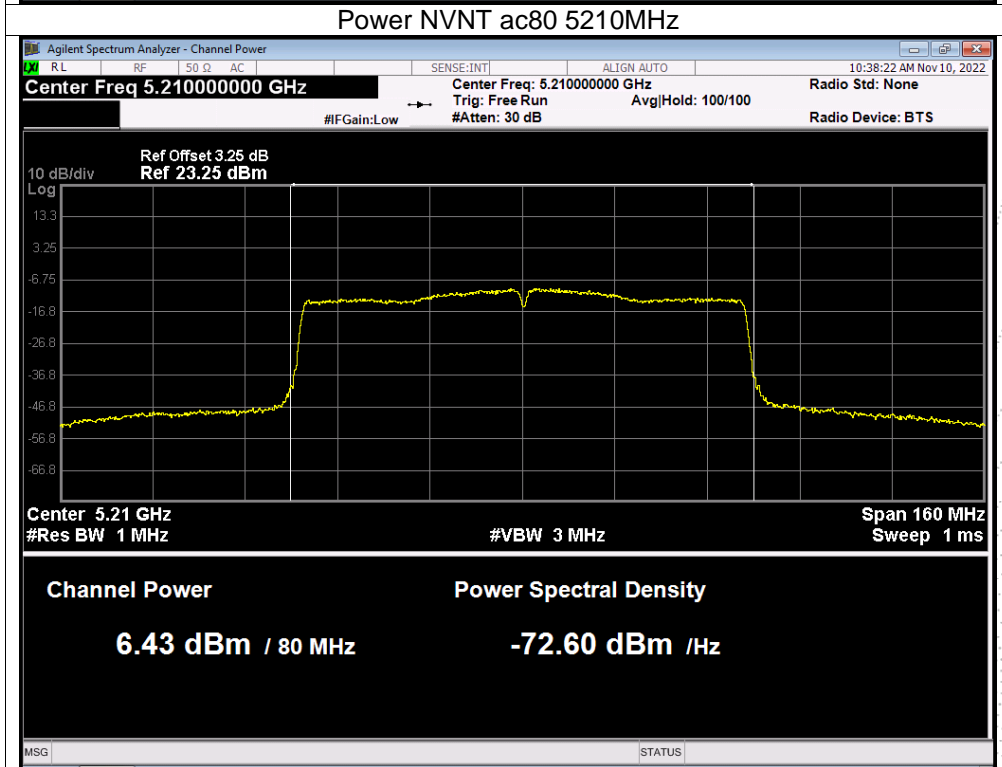
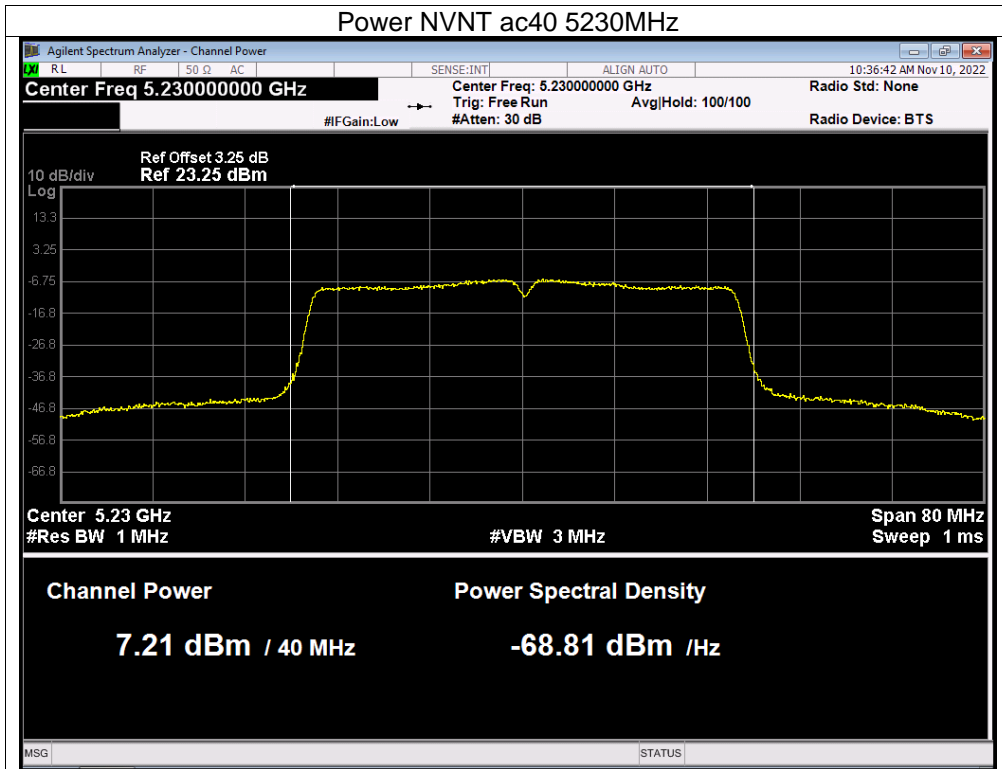

TC
3C
PPR
測

11. Out Of Band Emissions

11.1 Block Diagram Of Test Setup



11.2 Limit

According to RSS-247 6.2.2.2

Undesirable emission limits. Except as shown in paragraph (b)(7) of this section, the maximum emissions outside of the frequency bands of operation shall be attenuated in accordance with the following limits:

All emissions outside the band 5150-5350 MHz shall not exceed -27 dBm/MHz e.i.r.p. and any emissions within the band 5150-5250 MHz shall meet the power spectral density limits of Section 6.2.1. The device shall be labelled "for indoor use only."

11.3 Test procedure

1. Check the calibration of the measuring instrument using either an internal calibrator or a known signal from an external generator.
2. Position the EUT without connection to measurement instrument. Turn on the EUT and connect its antenna terminal to measurement instrument via a low loss cable. Then set it to any one measured frequency within its operating range, and make sure the instrument is operated in its linear range.
3. Set RBW of spectrum analyzer to 1 MHz with a convenient frequency span.
4. Measure the highest amplitude appearing on spectral display and set it as a reference level. Plot the graph with marking the highest point and edge frequency.
5. Repeat above procedures until all measured frequencies were complete.

11.4 EUT operating Conditions

The EUT was configured for testing in a typical fashion (as a customer would normally use it). The EUT has been programmed to continuously transmit during test. This operating condition was tested and used to collect the included data

11.5 Test Result

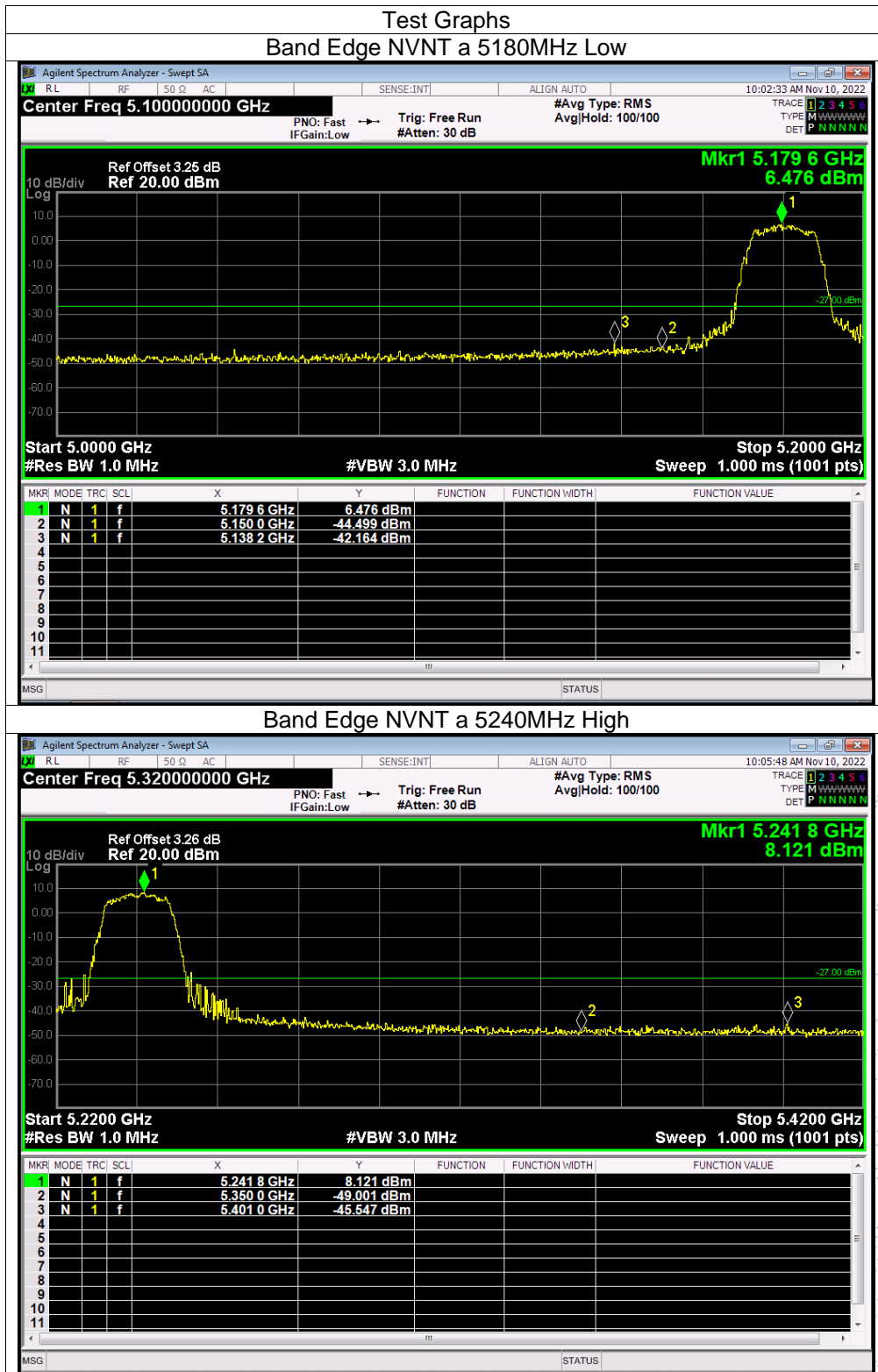

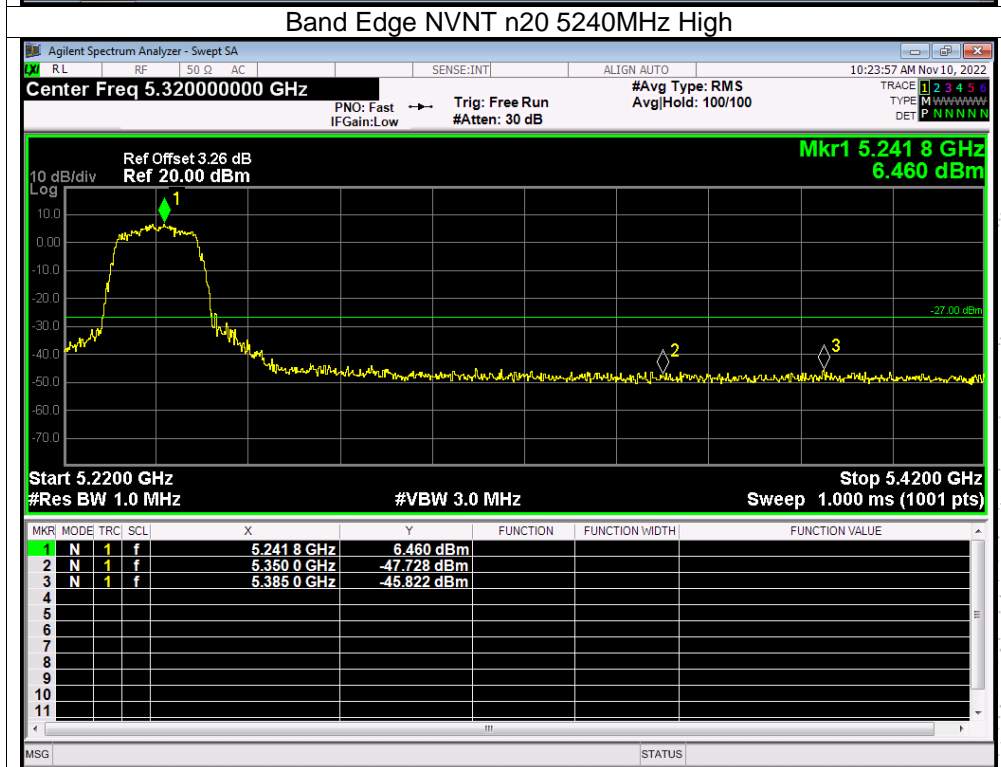
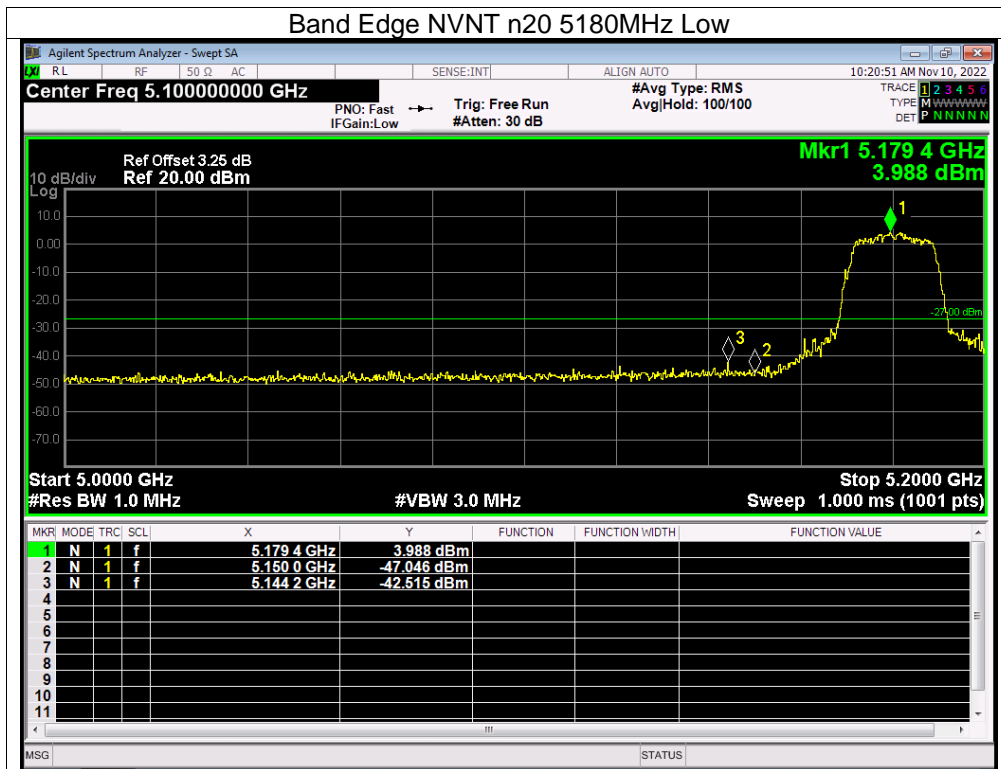

CO. LTD

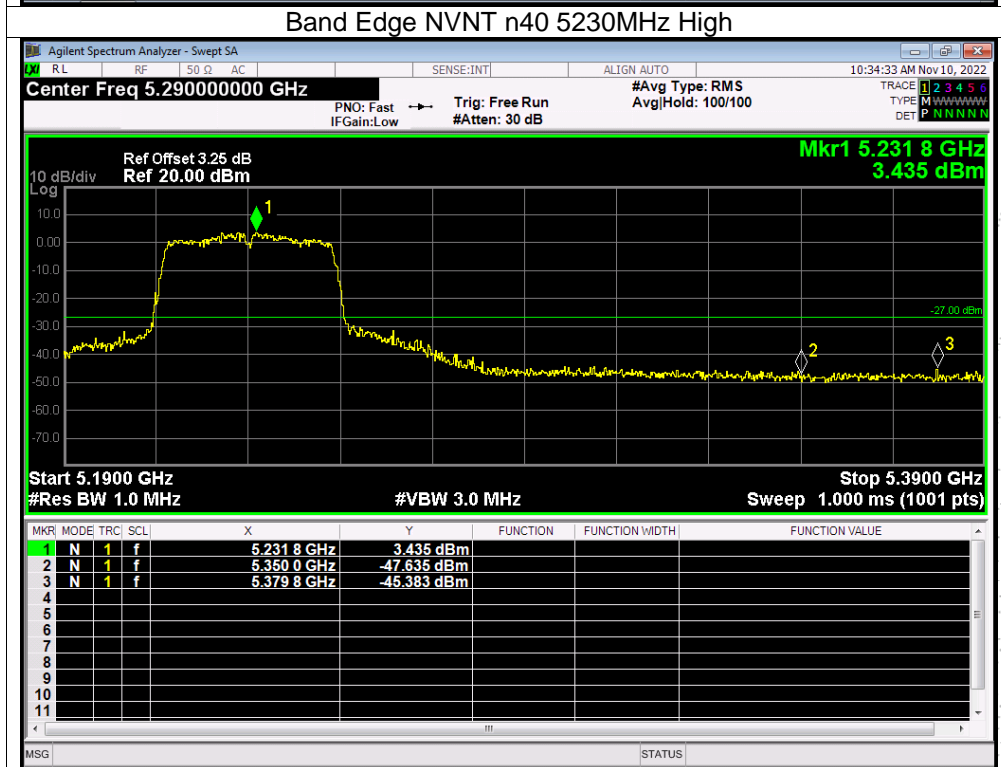
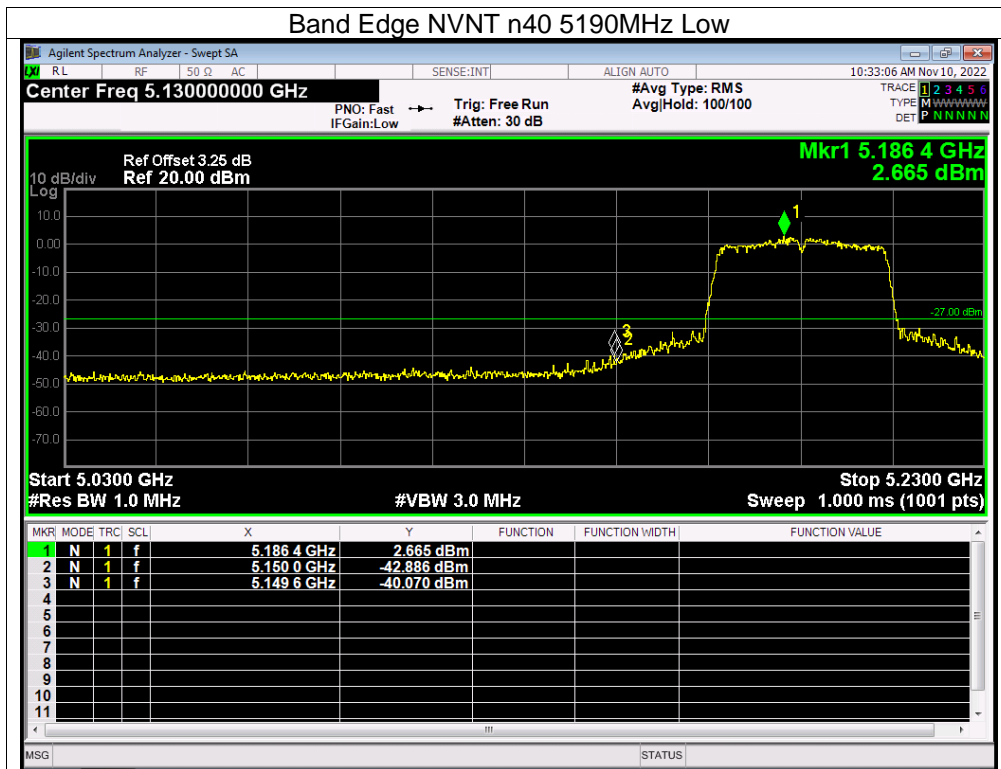

CHENZHEN

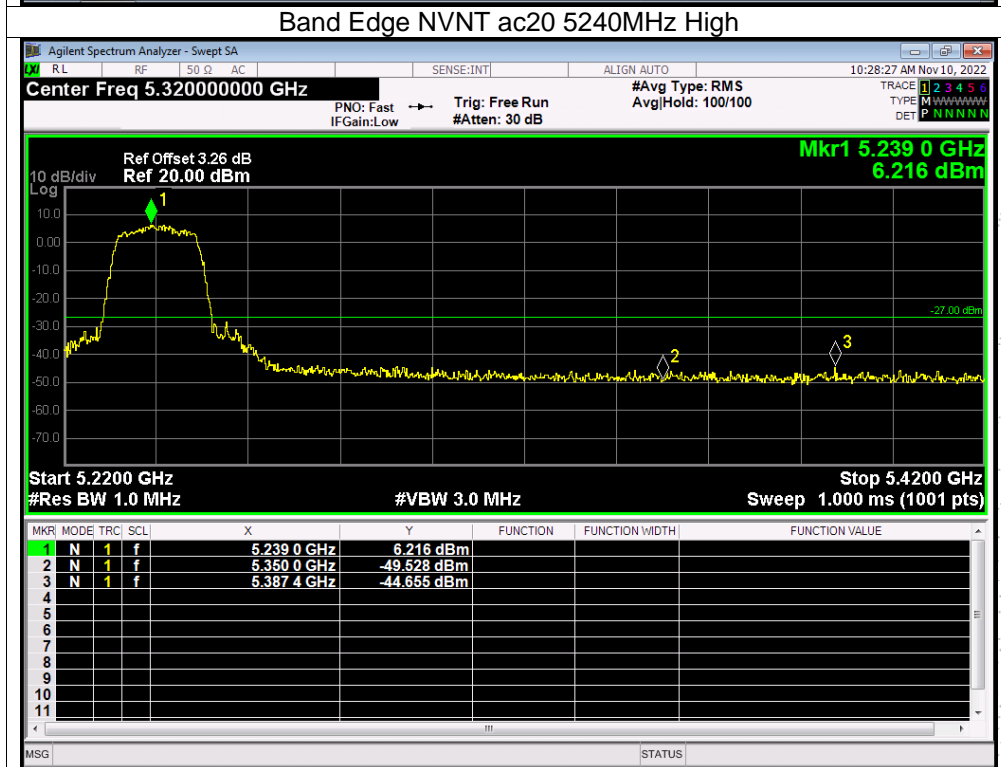
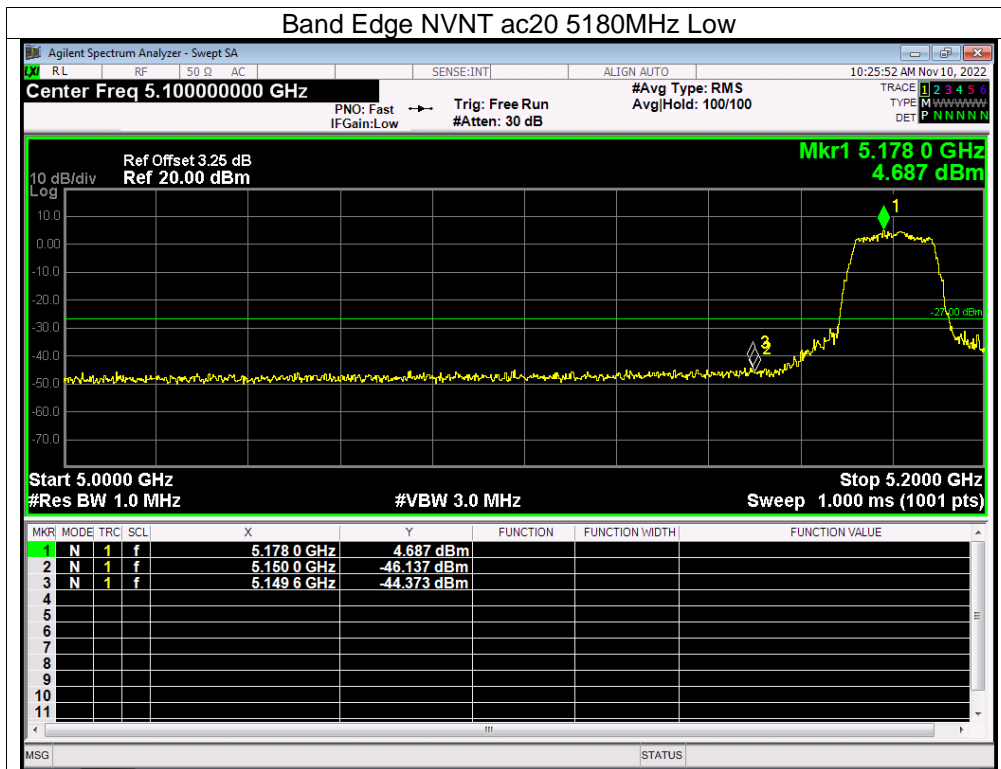

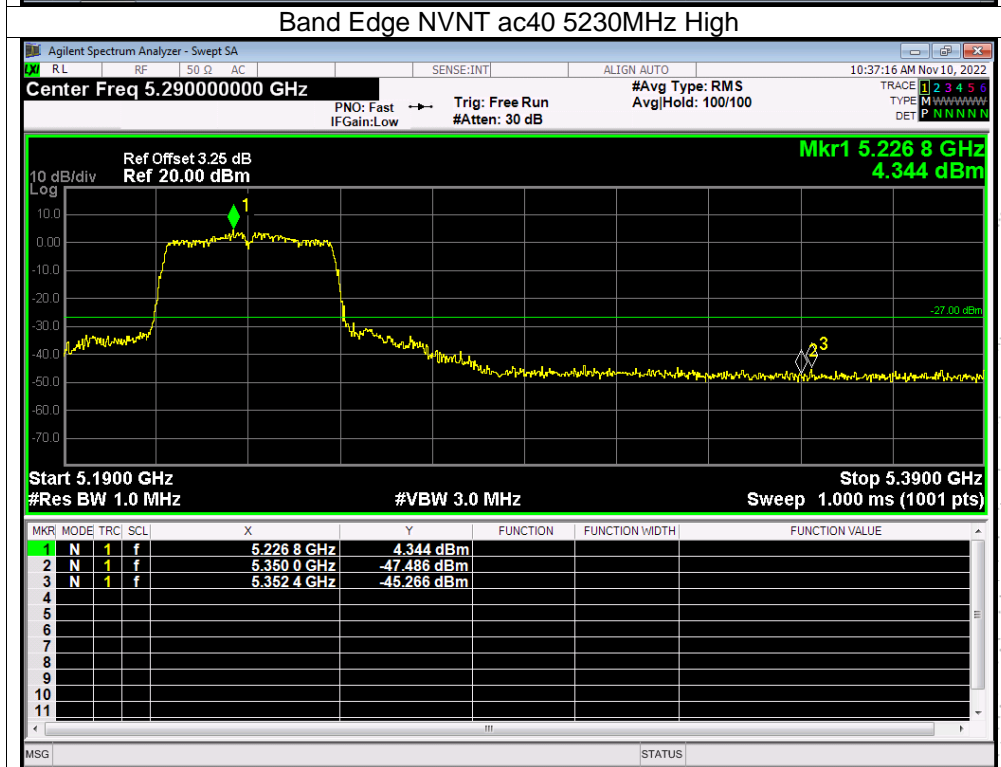
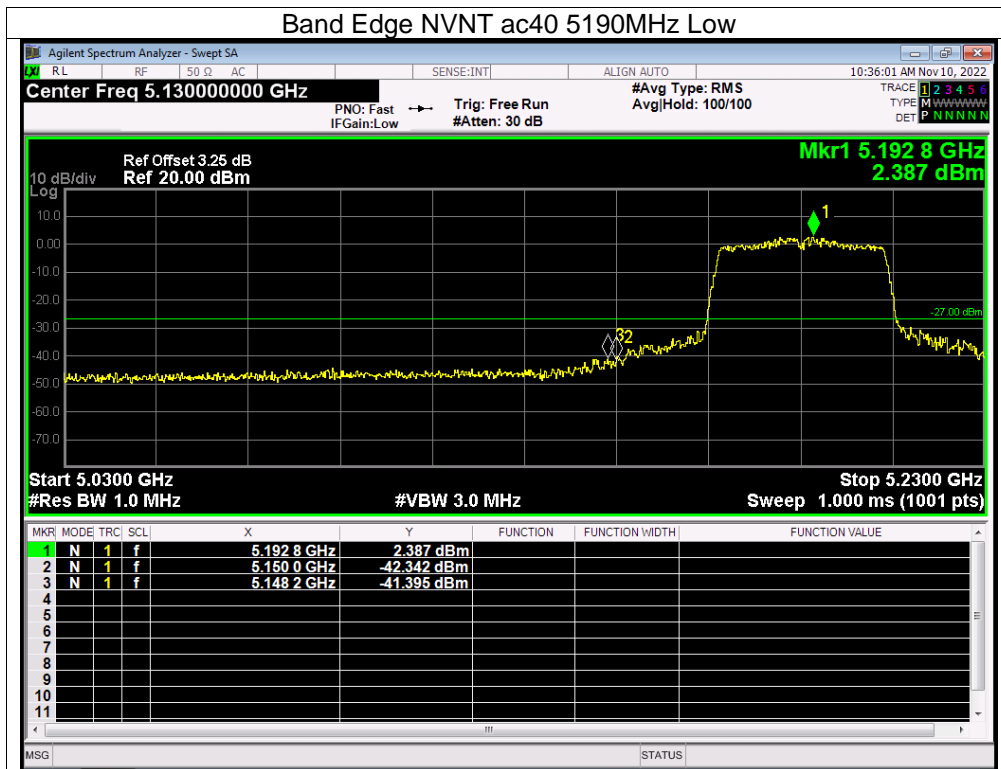

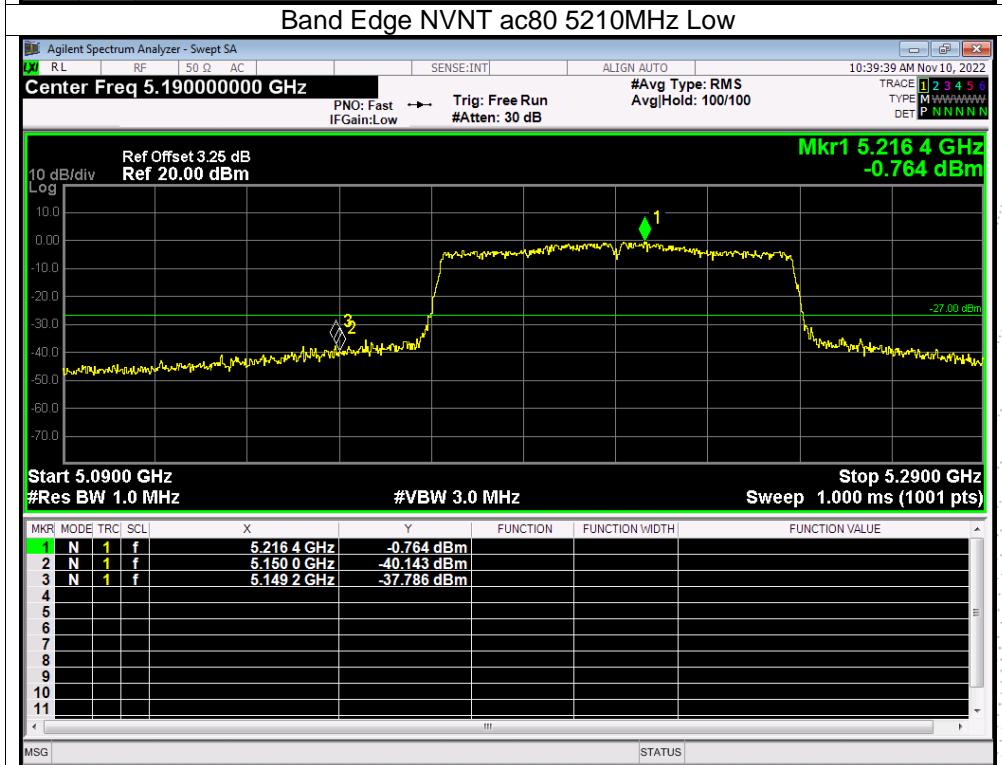
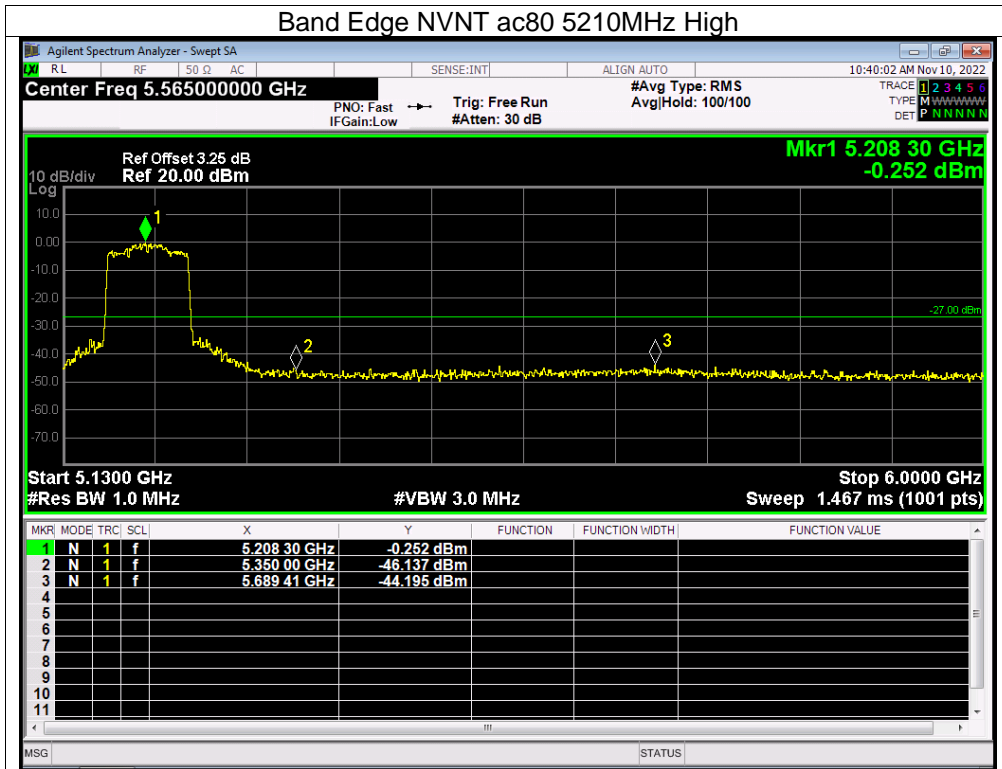

12. Spurious RF Conducted Emissions

12.1 Block Diagram Of Test Setup

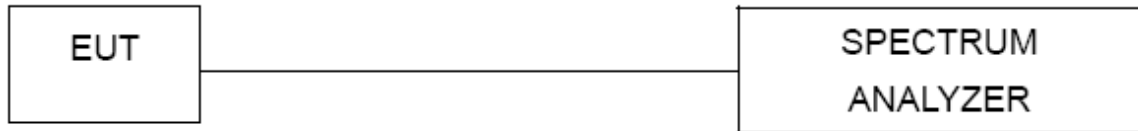

12.2 Limit

According to RSS-247 6.2.2.2

Undesirable emission limits. Except as shown in paragraph (b)(7) of this section, the maximum emissions outside of the frequency bands of operation shall be attenuated in accordance with the following limits:

All emissions outside the band 5150-5350 MHz shall not exceed -27 dBm/MHz e.i.r.p. and any emissions within the band 5150-5250 MHz shall meet the power spectral density limits of Section 6.2.1. The device shall be labelled "for indoor use only."

12.3 Test procedure

The Spurious RF conducted emissions compliance of RF radiated emission should be measured by following the guidance in ANSI C63.10-2013 with respect to maximizing the emission by rotating the EUT, measuring the emission while the EUT is situated in three orthogonal planes (if appropriate), adjusting the measurement antenna height and polarization etc. Set RBW=100kHz and VBW= 300kHz to measure the peak field strength , and mwasure frequency range from 9kHz to 26.5GHz.

12.4 Test Result

Remark: The measurement frequency range is from 9kHz to the 10th harmonic of the fundamental frequency. The lowest, middle and highest channels are tested to verify the spurious emissions and bandedge measurement data.

About:26.5GHz-40GHz, The amplitude of spurious emissions which are attenuated by more than 20dB below the permissible value has no need to be reported.

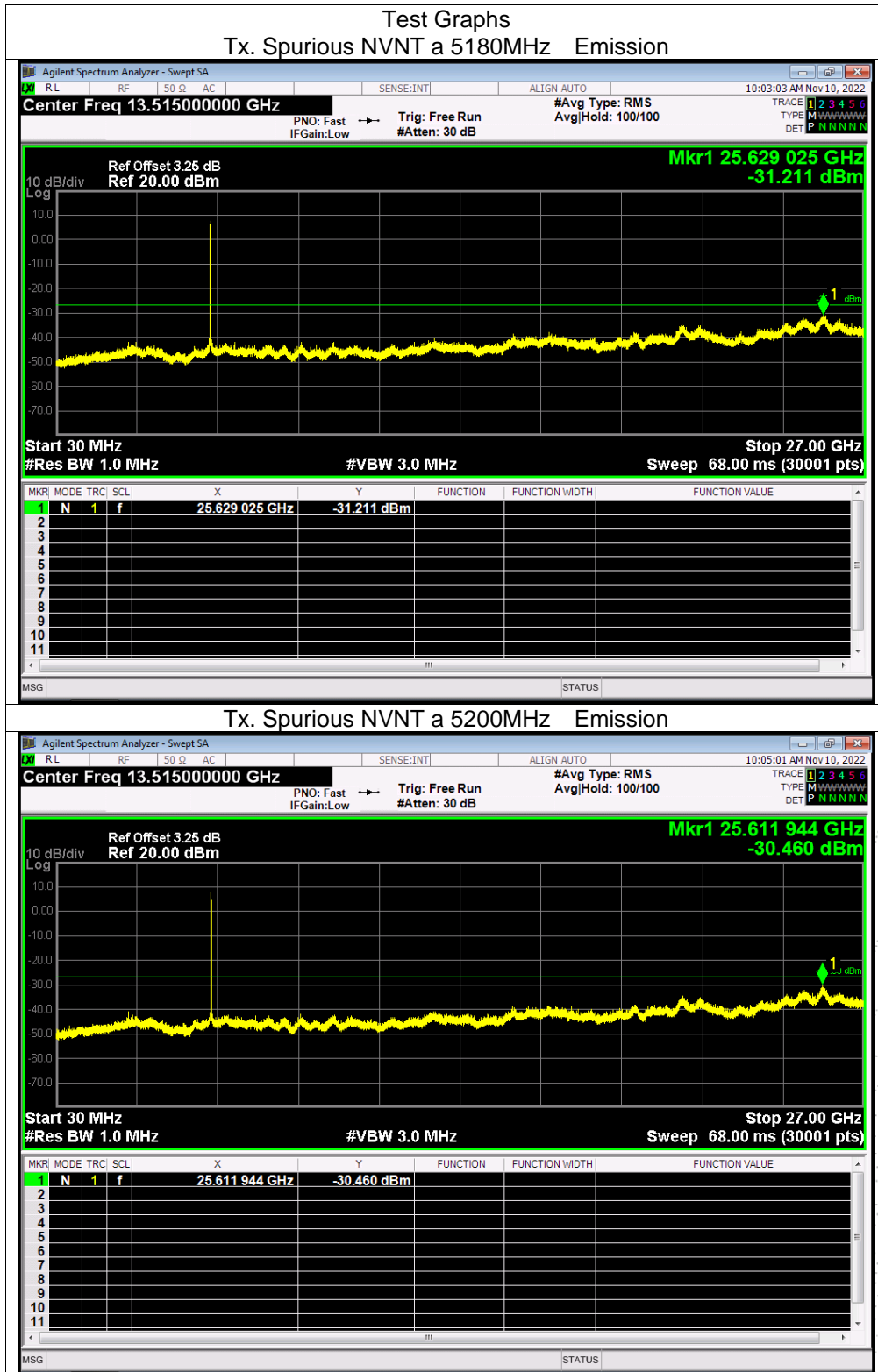

CO. LTD

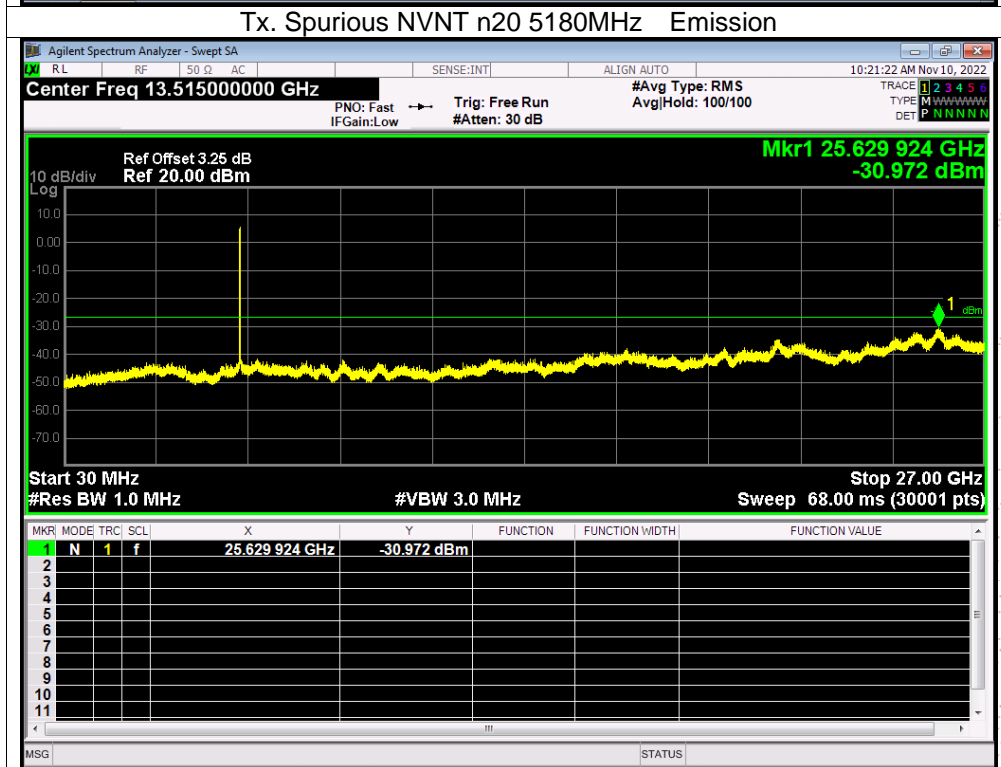
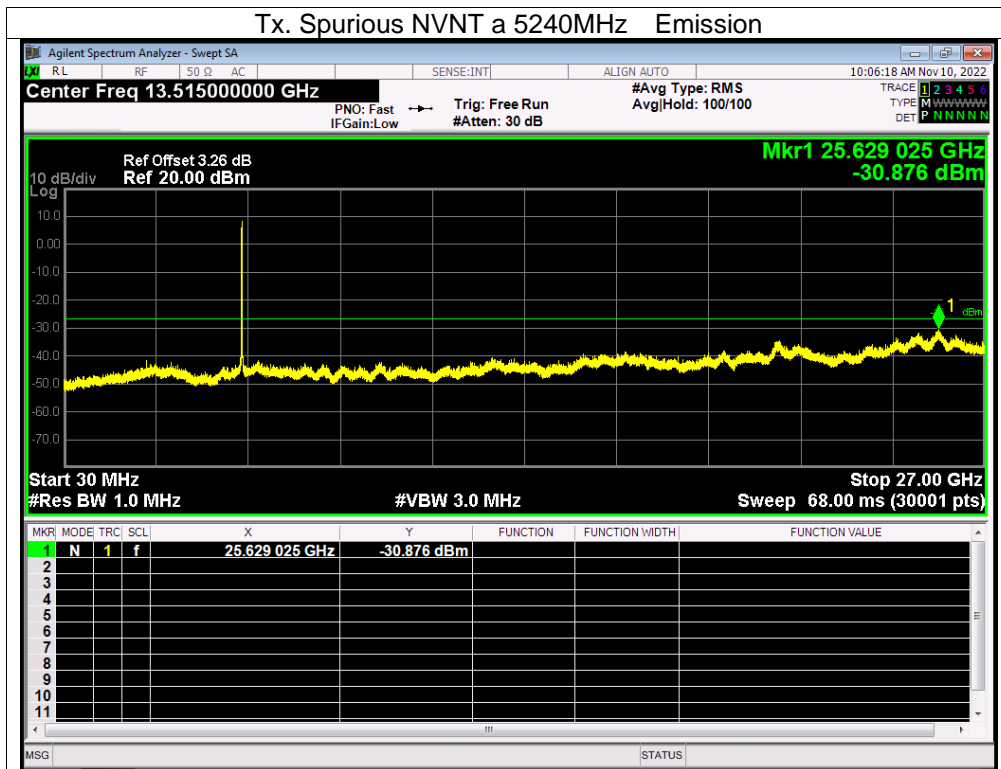

CHENZHEN

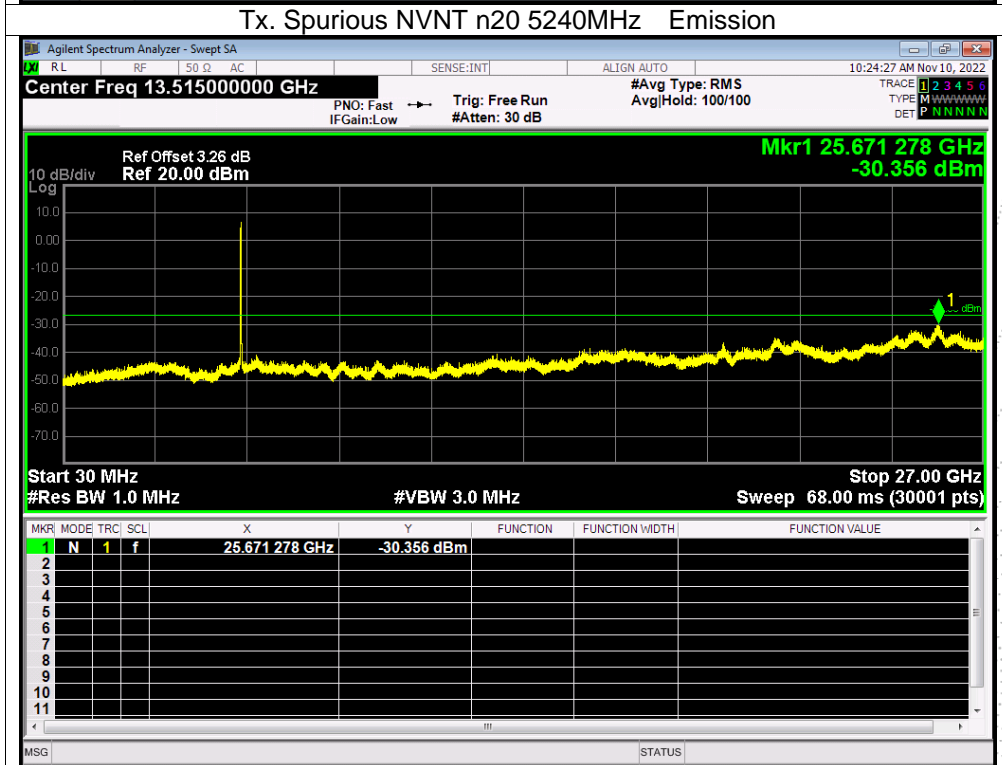
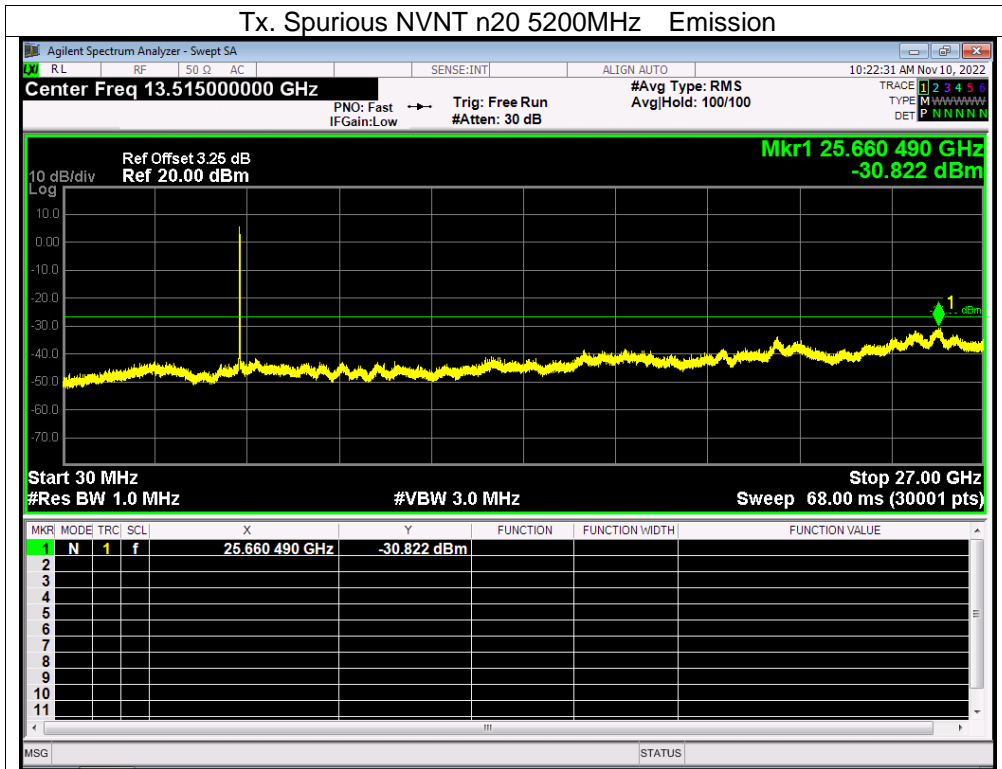

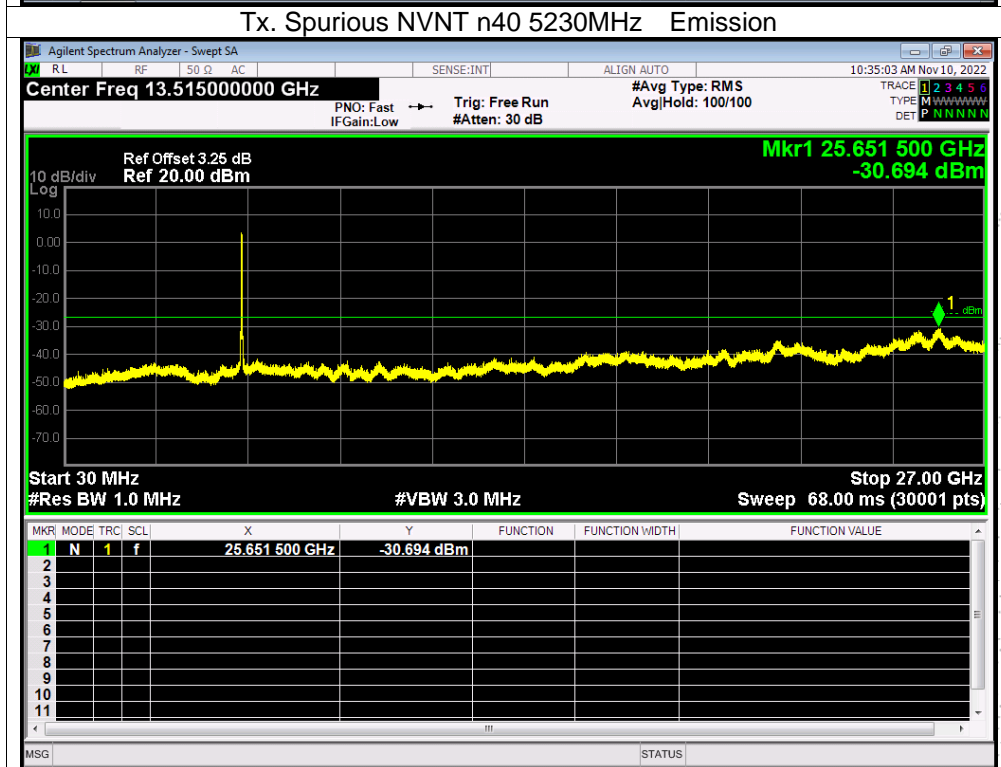
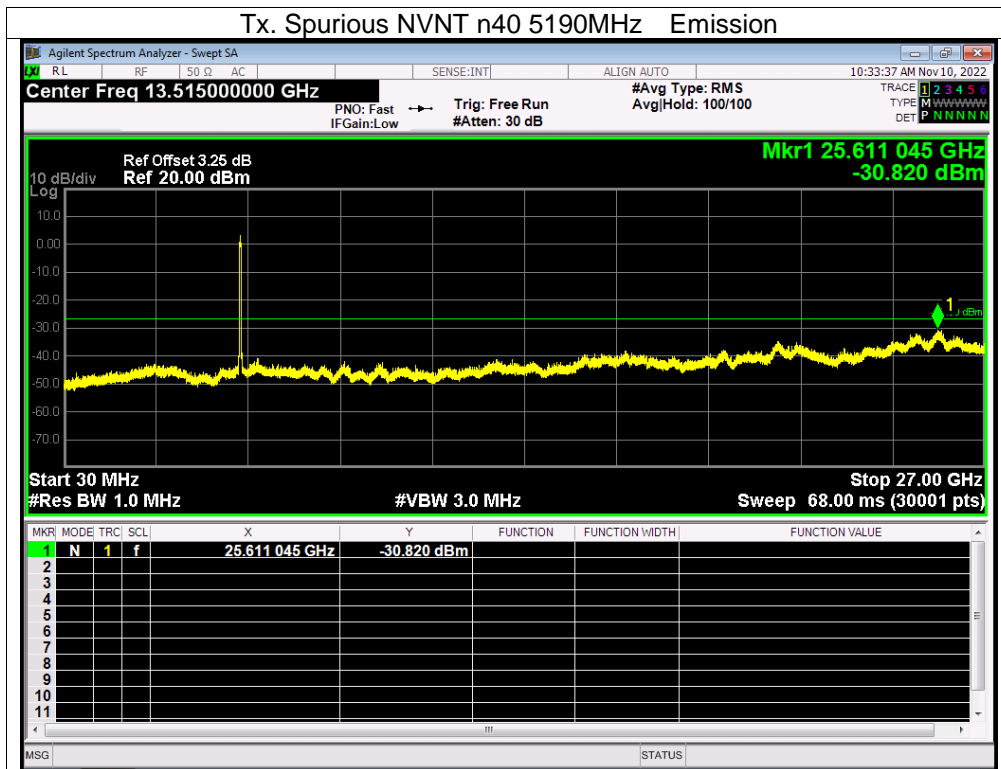

BCTC
 BCTC
 PPR
 检测

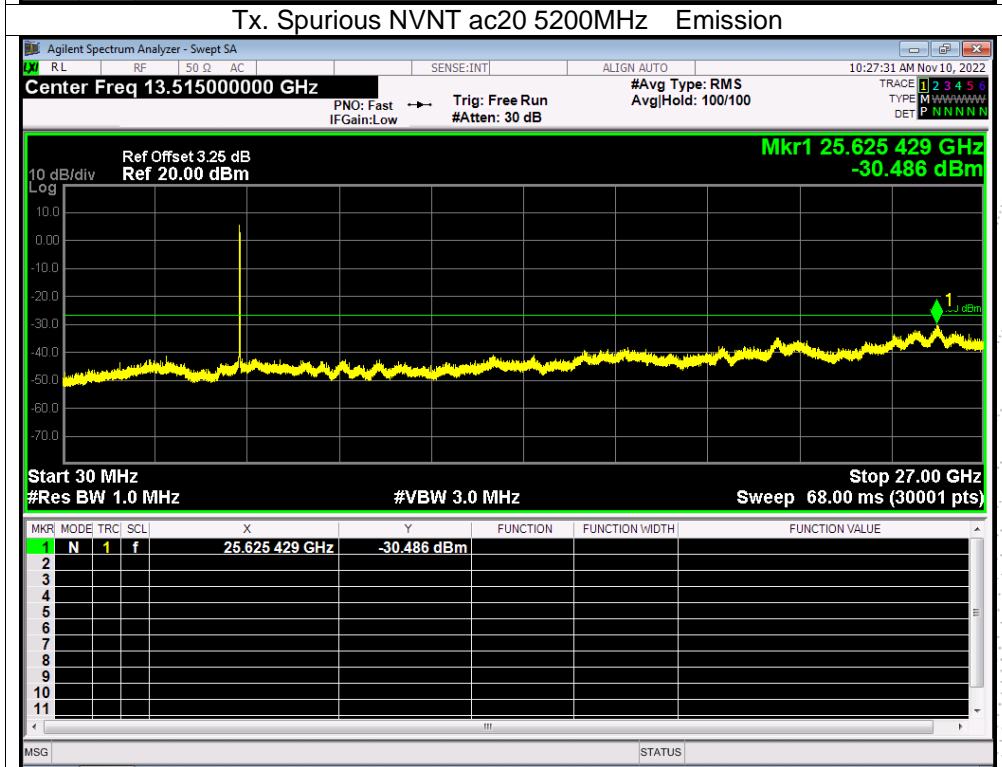
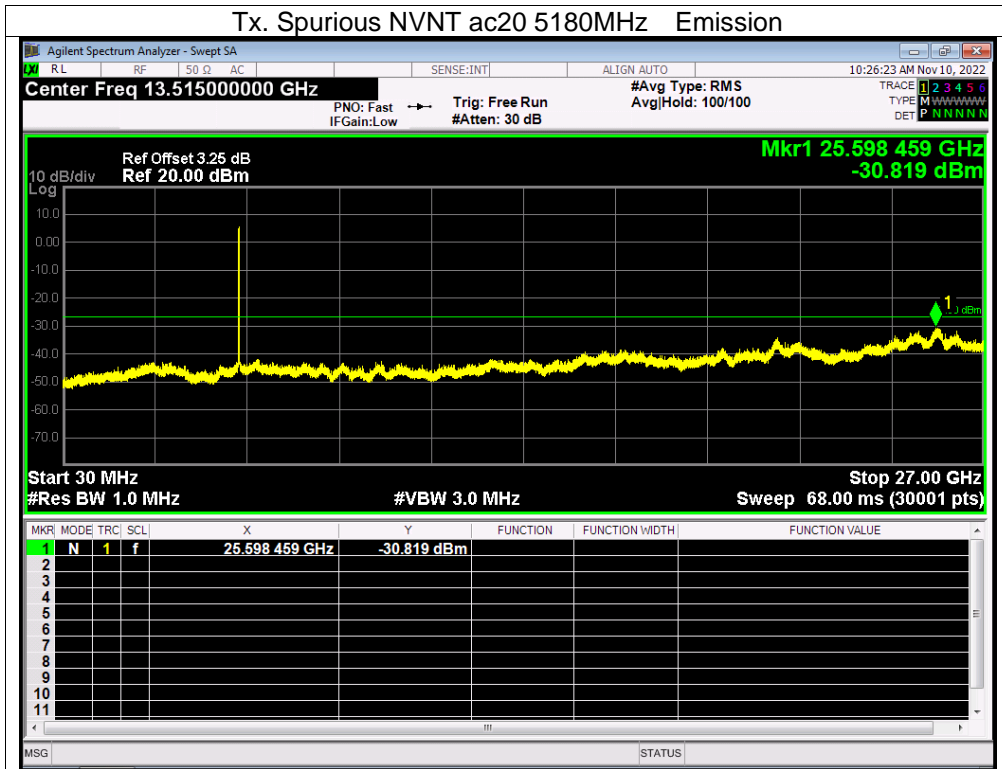

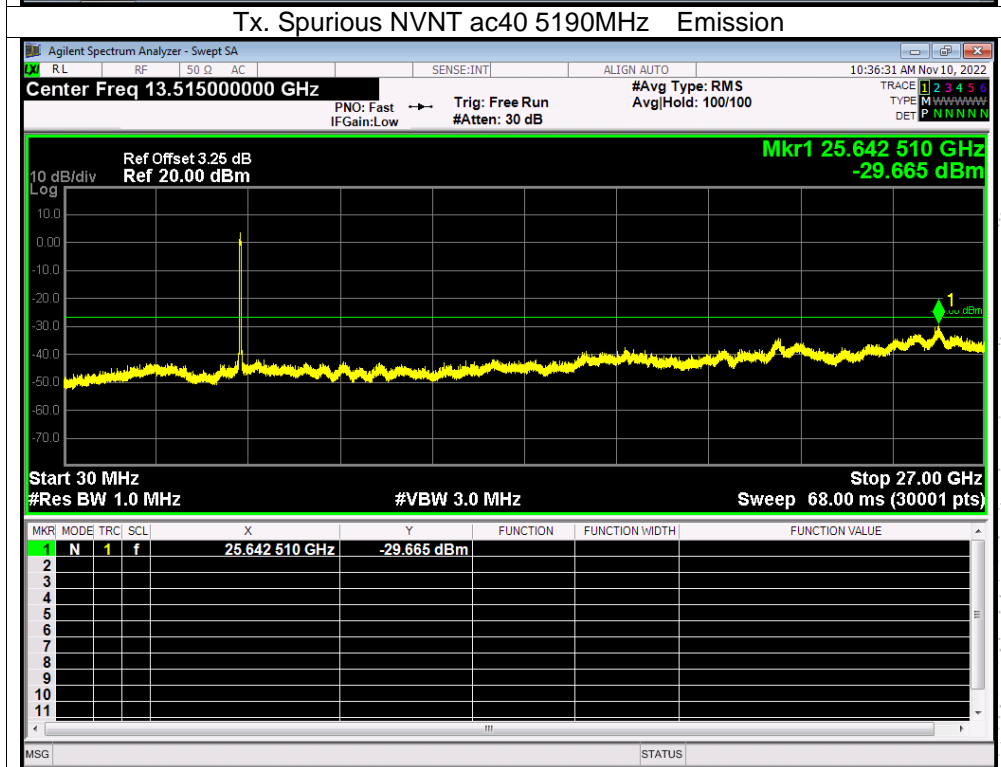
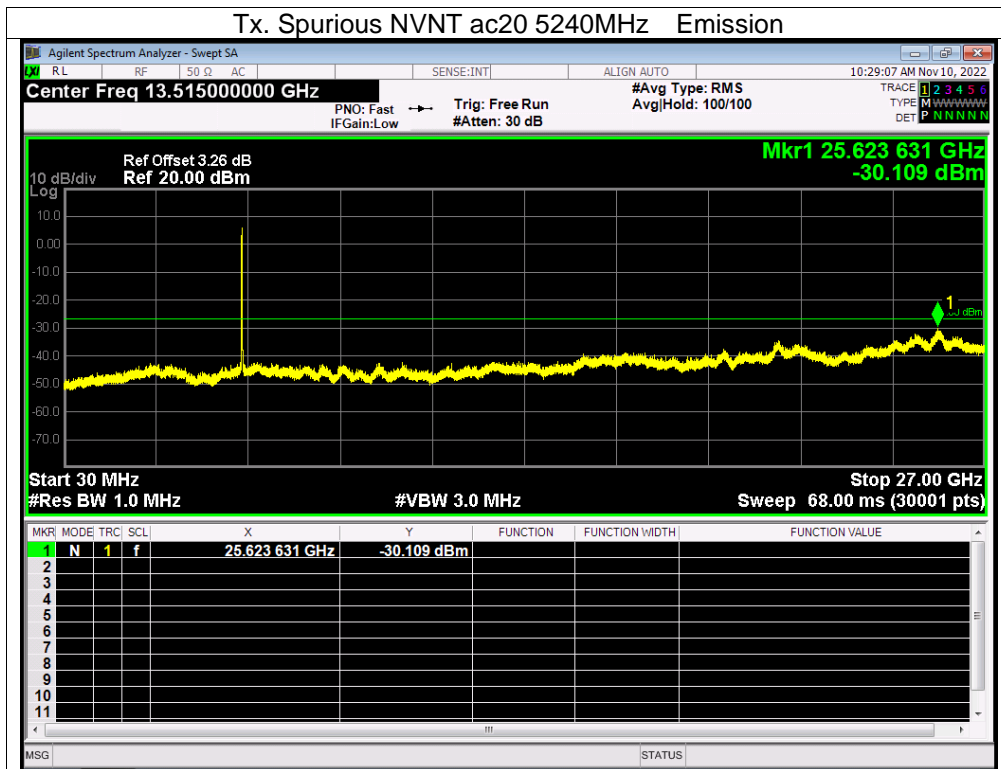

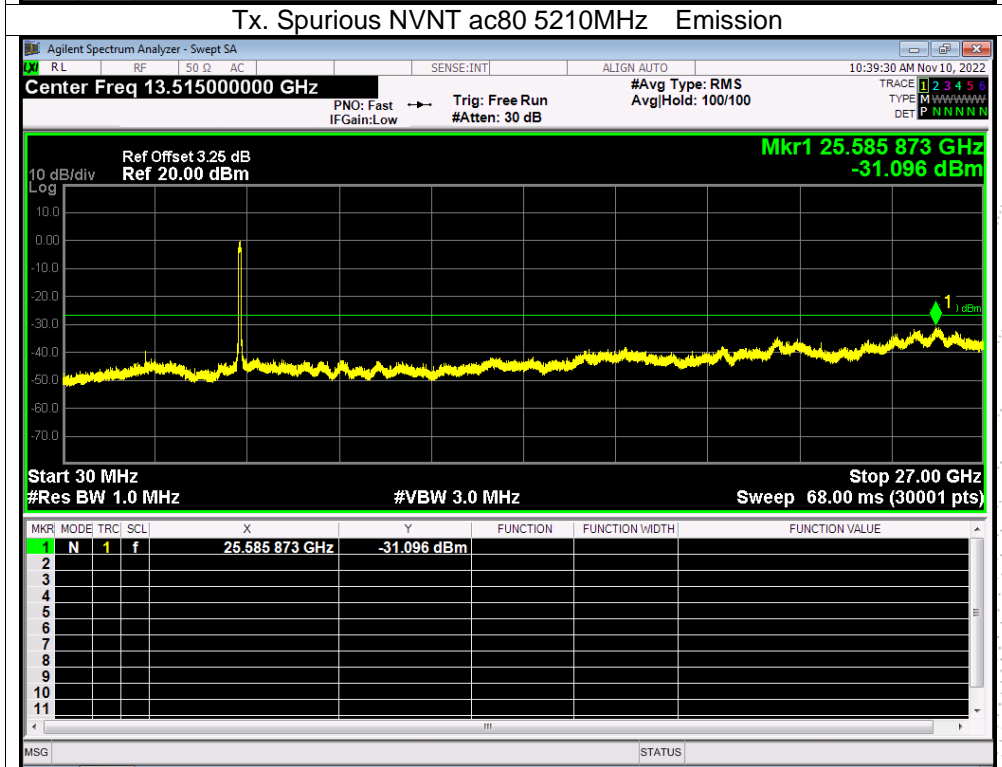
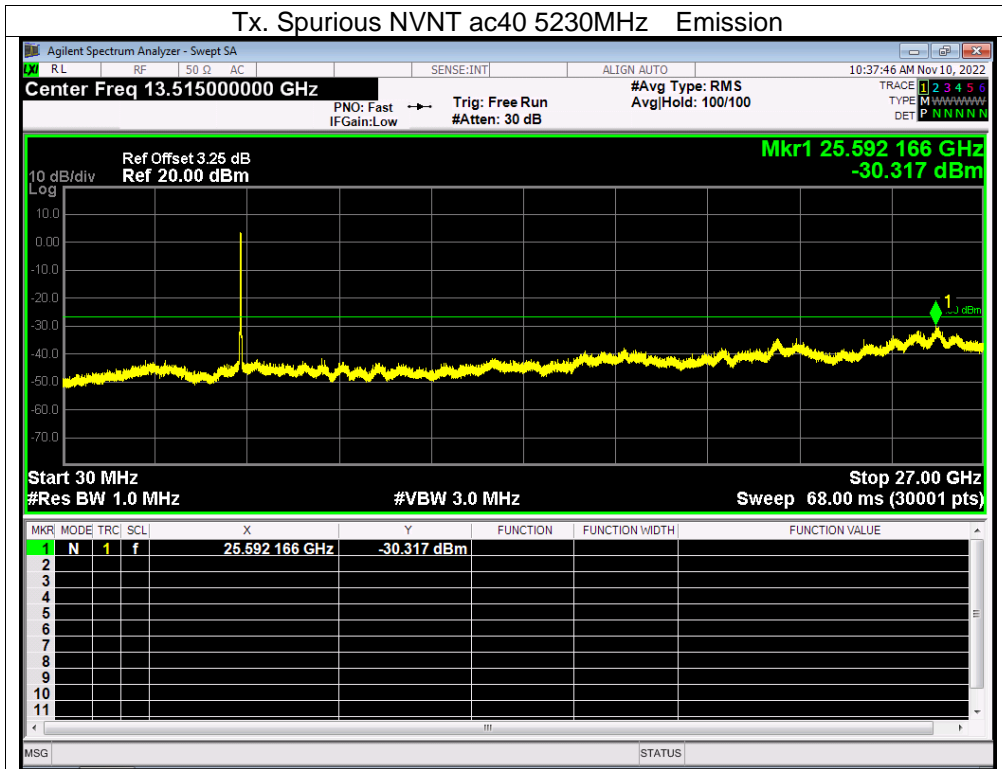

CO., LTD

13. Frequency Stability Measurement

13.1 Block Diagram Of Test Setup



13.2 Limit

Manufactures of U-NII devices are responsible for ensuring frequency stability such that an emission is maintained within the band of operation under all conditions of normal operation as specified in the user's manual.

The transmitter center frequency tolerance shall be ± 20 ppm maximum for the 5 GHz band (IEEE 802.11n specification).

13.3 Test procedure

1. The transmitter output (antenna port) was connected to the spectrum analyzer.
2. EUT have transmitted absence of modulation signal and fixed channelize.
3. Set the spectrum analyzer span to view the entire absence of modulation emissions bandwidth.
4. Set RBW = 10 kHz, VBW = 10 kHz with peak detector and maxhold settings.
5. f_c is declaring of channel frequency. Then the frequency error formula is $(f_c - f) / f_c \times 10^6$ ppm and he limit is less than ± 20 ppm (IEEE 802.11n specification).
6. The test extreme voltage is to change the primary supply voltage from 85 to 115 percent of the nominal value
7. Extreme temperature is -20°C ~ 70°C .

13.4 Test Result

Temperature:	26 °C	Relative Humidity:	54%
Pressure:	101KPa	Test Voltage:	DC 12V
Test Mode:	TX (5.1G) Mode Frequency U-NII-1 (5180-5240MHz)		

Voltage vs. Frequency Stability

TEST CONDITIONS				Reference Frequency: 5180MHz			
				f	fc	Max. Deviation (MHz)	Max. Deviation (ppm)
T nom (°C)	20	V nom (V)	12.00	5180.0206	5180	0.0206	3.9858
		V max (V)	13.80	5180.0140	5180	0.0140	2.7112
		V min (V)	10.20	5180.0080	5180	0.0080	1.5357
Limits				5150-5250 MHz			
Result				Complies			

Temperature vs. Frequency Stability

TEST CONDITIONS				Reference Frequency: 5180MHz			
				f	fc	Max. Deviation (MHz)	Max. Deviation (ppm)
V nom (V)	12	T (°C)	-20	5180.0104	5180	0.0104	2.0036
		T (°C)	-10	5180.0063	5180	0.0063	1.2154
		T (°C)	0	5180.0121	5180	0.0121	2.3284
		T (°C)	10	5180.0116	5180	0.0116	2.2370
		T (°C)	20	5180.0050	5180	0.0050	0.9557
		T (°C)	30	5180.0019	5180	0.0019	0.3676
		T (°C)	40	5180.0078	5180	0.0078	1.5057
		T (°C)	50	5180.0039	5180	0.0039	0.7619
		T (°C)	60	5180.0085	5180	0.0085	1.6367
		T (°C)	70	5180.0049	5180	0.0049	0.9445
Limits				5150-5250 MHz			
Result				Complies			

Voltage vs. Frequency Stability

TEST CONDITIONS				Reference Frequency: 5200MHz			
				f	fc	Max. Deviation (MHz)	Max. Deviation (ppm)
T nom (°C)	20	V nom (V)	12.00	5200.0101	5200	0.0101	1.9509
		V max (V)	13.80	5200.0066	5200	0.0066	1.2739
		V min (V)	10.20	5200.0107	5200	0.0107	2.0662
Limits				5725-5850 MHz			
Result				Complies			

Temperature vs. Frequency Stability

TEST CONDITIONS				Reference Frequency: 5200MHz			
				f	fc	Max. Deviation (MHz)	Max. Deviation (ppm)
V nom (V)	12	T (°C)	-20	5200.00292	5200	0.00292	0.5623
		T (°C)	-10	5200.01327	5200	0.01327	2.5526
		T (°C)	0	5200.00842	5200	0.00842	1.6196
		T (°C)	10	5200.01233	5200	0.01233	2.3719
		T (°C)	20	5200.01214	5200	0.01214	2.3355
		T (°C)	30	5200.00622	5200	0.00622	1.1966
		T (°C)	40	5200.00009	5200	0.00009	0.0179
		T (°C)	50	5200.01047	5200	0.01047	2.0132
		T (°C)	60	5200.01057	5200	0.01057	2.0330
		T (°C)	70	5200.00872	5200	0.00872	1.6778
Limits				5150-5250 MHz			
Result				Complies			

Voltage vs. Frequency Stability

TEST CONDITIONS				Reference Frequency: 5240MHz			
				f	fc	Max. Deviation (MHz)	Max. Deviation (ppm)
T nom (°C)	20	V nom (V)	12.00	5240.0037	5240	0.0037	0.6989
		V max (V)	13.80	5240.0039	5240	0.0039	0.7502
		V min (V)	10.20	5240.0127	5240	0.0127	2.4212
Limits				5150-5250 MHz			
Result				Complies			

Temperature vs. Frequency Stability

TEST CONDITIONS				Reference Frequency: 5240MHz			
				f	fc	Max. Deviation (MHz)	Max. Deviation (ppm)
V nom (V)	12	T (°C)	-20	5240.0125	5240	0.0125	2.3778
		T (°C)	-10	5240.0030	5240	0.0030	0.5812
		T (°C)	0	5240.0017	5240	0.0017	0.3183
		T (°C)	10	5240.0120	5240	0.0120	2.2887
		T (°C)	20	5240.0029	5240	0.0029	0.5467
		T (°C)	30	5240.0040	5240	0.0040	0.7625
		T (°C)	40	5240.0046	5240	0.0046	0.8694
		T (°C)	50	5240.0120	5240	0.0120	2.2942
		T (°C)	60	5240.0080	5240	0.0080	1.5309
		T (°C)	70	5240.0113	5240	0.0113	2.1534
Limits				5150-5250 MHz			
Result				Complies			

14. Antenna Requirement

14.1 Limit

According to RSS-Gen issue 5, section 6.8, a transmitter can only be sold or operated with antennas with which it was certified. A transmitter may be certified with multiple antenna types. An antenna type comprises antennas having similar in-band and out-of-band radiation patterns.

14.2 Test Antenna

The EUT antenna is FPC antenna. It comply with the standard requirement.

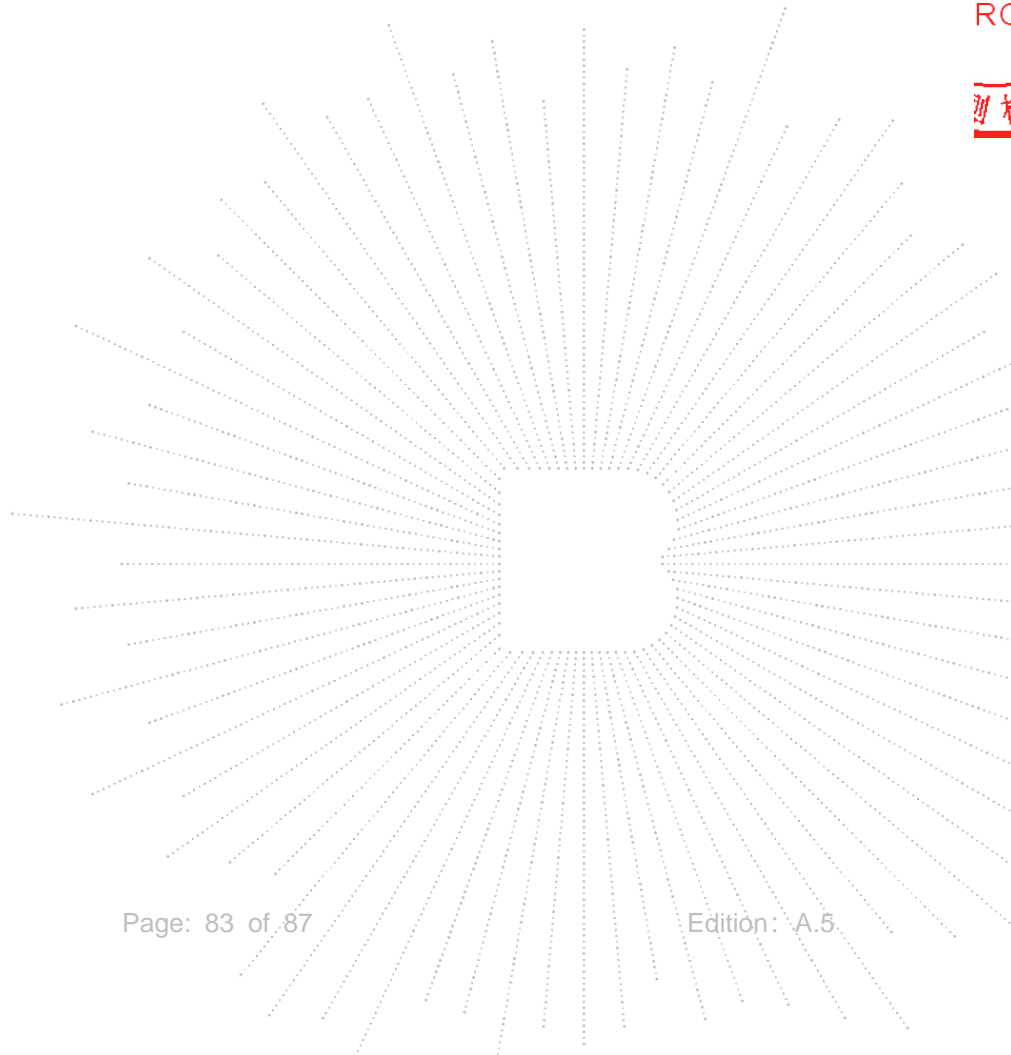

15. EUT Photographs

EUT Photo

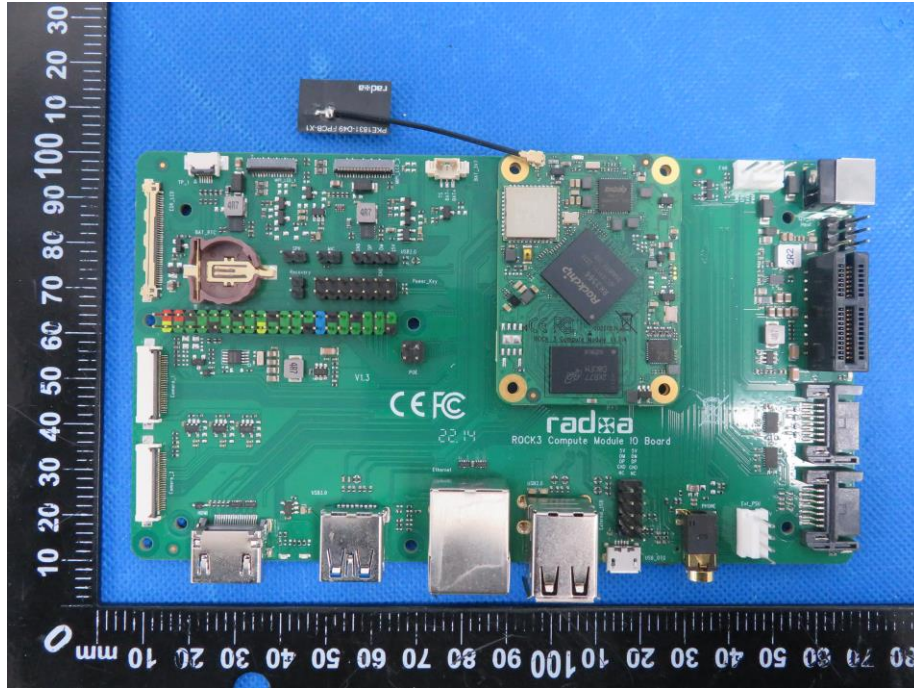

NOTE: Appendix-Photographs Of EUT Constructional Details

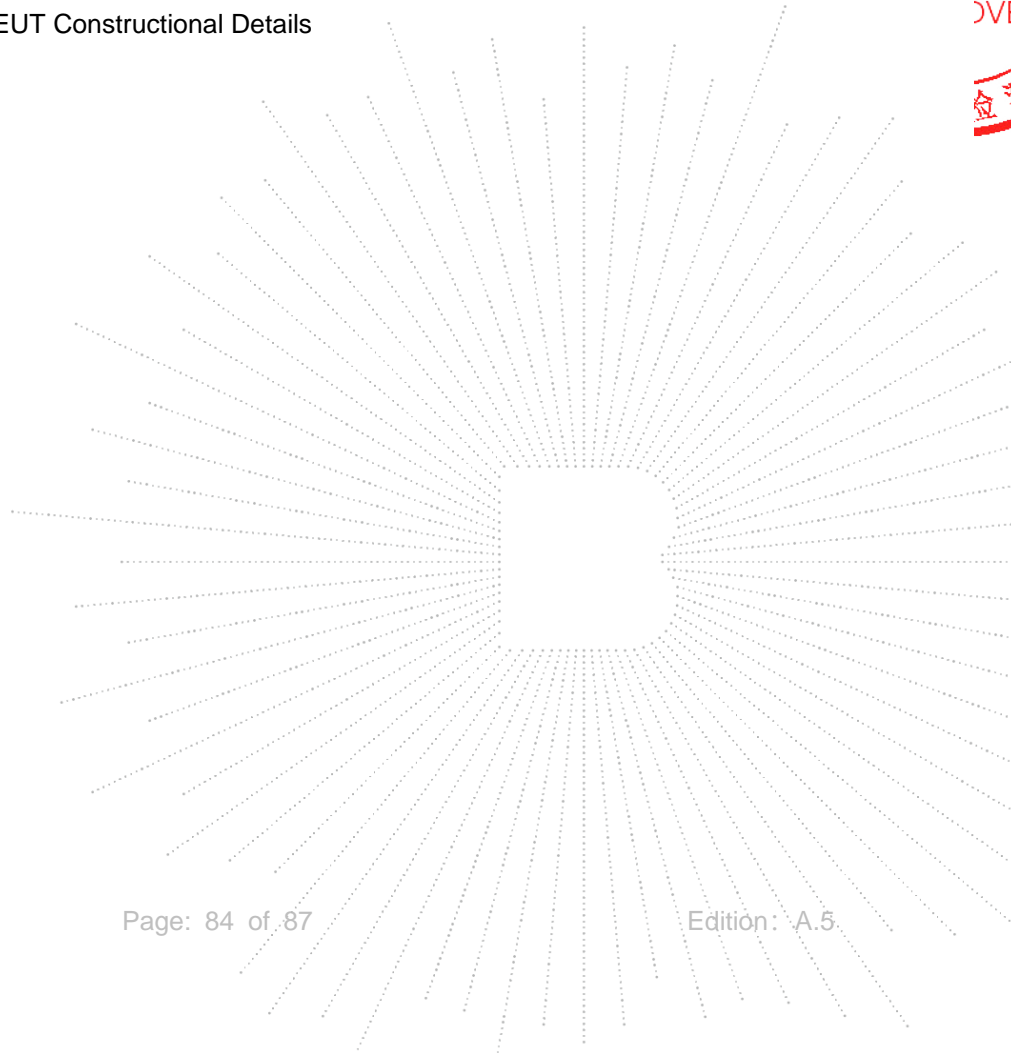

16. EUT Test Setup Photographs

Conducted Measurement Photo

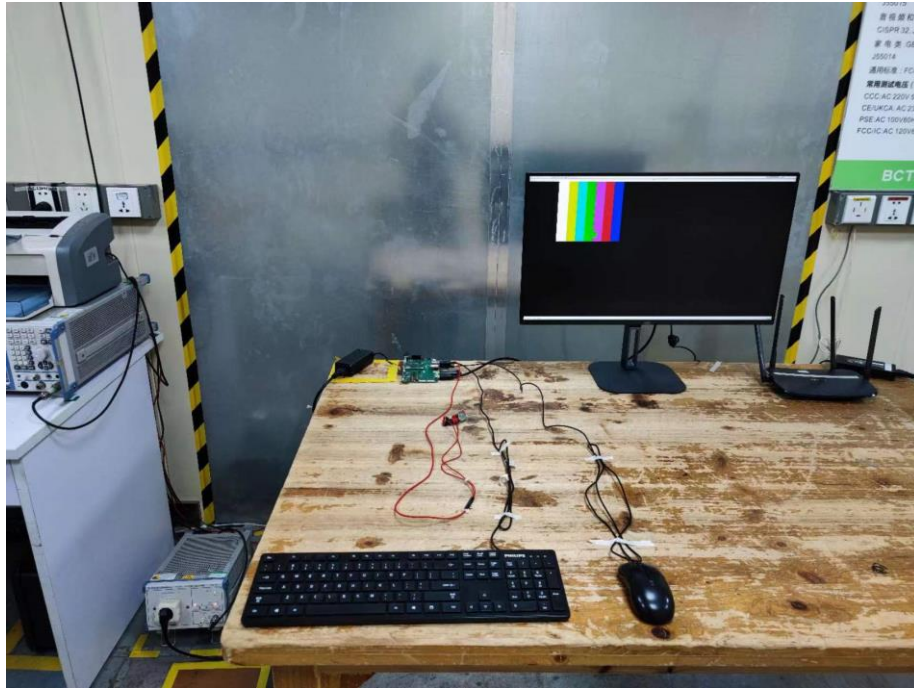

Radiated Measurement Photos

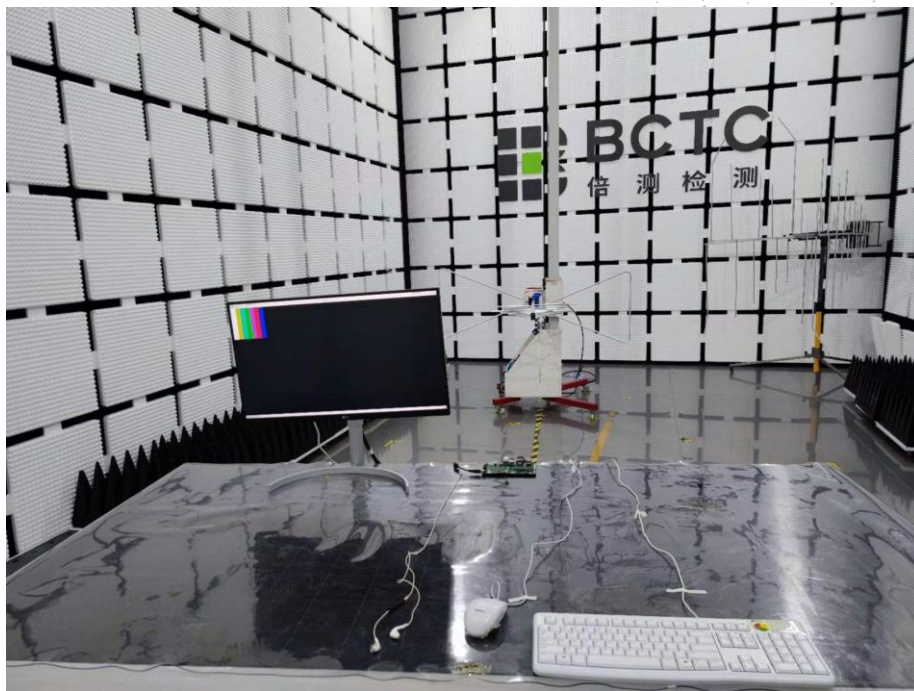

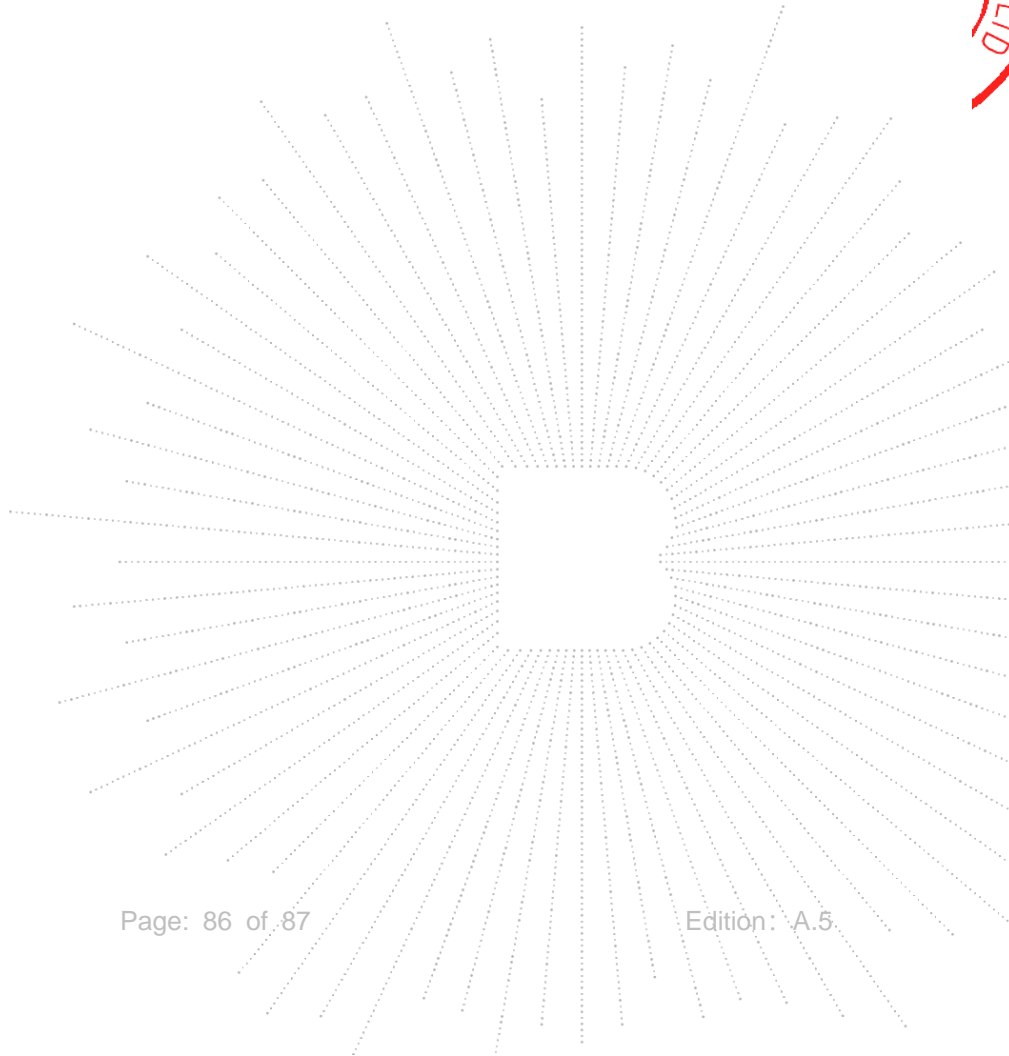
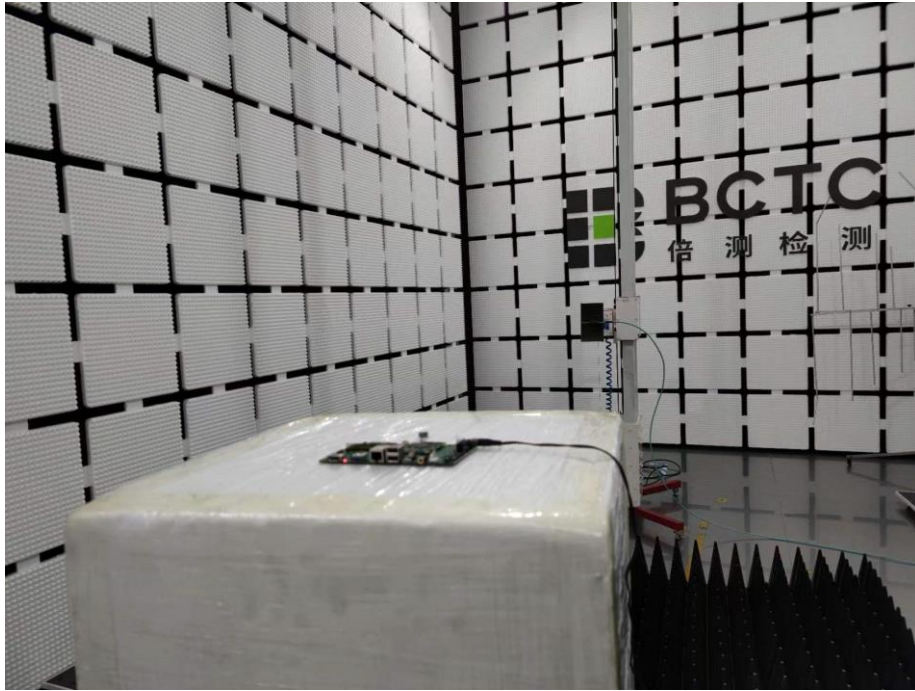

STATEMENT

1. The equipment lists are traceable to the national reference standards.
2. The test report can not be partially copied unless prior written approval is issued from our lab.
3. The test report is invalid without the "special seal for inspection and testing".
4. The test report is invalid without the signature of the approver.
5. The test process and test result is only related to the Unit Under Test.
6. Sample information is provided by the client and the laboratory is not responsible for its authenticity.
7. The test report without CMA mark is only used for scientific research, teaching, enterprise product development and internal quality control purposes.
8. The quality system of our laboratory is in accordance with ISO/IEC17025.
9. If there is any objection to this test report, the client should inform issuing laboratory within 15 days from the date of receiving test report.

Address:

1-2/F., Building B, Pengzhou Industrial Park, No.158, Fuyuan 1st Road, Zhancheng, Fuhai Subdistrict, Bao'an District, Shenzhen, Guangdong, China

TEL: 400-788-9558

P.C.: 518103

FAX: 0755-33229357

Website: <http://www.chnbctc.com>

E-Mail: bctc@bctc-lab.com.cn

***** END *****

2017