

Table of Content

Page 1	01.Index_and_Notes
Page 2	02.Revision_History
Page 3	03.Block_Diagram
Page 4	04.RS232/RS485/CAN
Page 5	05.RTL8367RB-VB_LED
Page 6	06.RTL8367RB-VB_RJ45
Page 7	07.RTL8367RB_VB_1000M
Page 8	08.M.2 B KEY
Page 9	09.M.2 M KEY
Page 10	10.M.2 E KEY
Page 11	11.PCIE_CLK
Page 12	12.SATA SW
Page 13	13.MIPI_CSI_RX
Page 14	14.EDP_LCD
Page 15	15.LVDS_LCD
Page 16	16.MicroSD Card
Page 17	17.HDMI_OUT
Page 18	18.Ethernet_1000M
Page 19	19.AUDIO/UART
Page 20	20.USB_OTG/HOST
Page 21	21.FAN_RTC_KEY
Page 22	22.Power DC IN
Page 23	23.POWER_POE
Page 24	24.GPIO+VCC_Connector
Page 25	25.High Speed Serial Connector
Page 26	26.IO_Connector
Page 27	27.IO2_Connector

Generate Bill of Materials

Header:

Item\tPart\tDescription\tPCB Footprint\tReference\tQuantity\tOption

Combined property string:

{Item}\t{Value}\t{Description}\t{PCB Footprint}\t{Reference}\t{Quantity}\t{Option}

Description

Note

Option

Notes

NOTE 1:
Component parameter description
1. DNP stands for component not mounted temporarily
2. If Value or option is DNP, which means the area is reserved without being mounted

NOTE 2:
Please use our recommended components to avoid too many changes.
For more informations about the second source, please refer to our AVL.



Giga PHY0

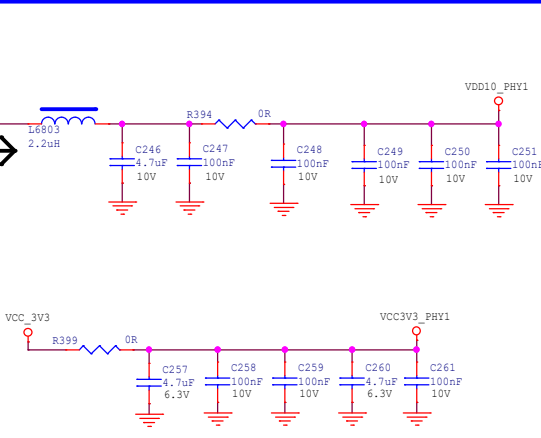
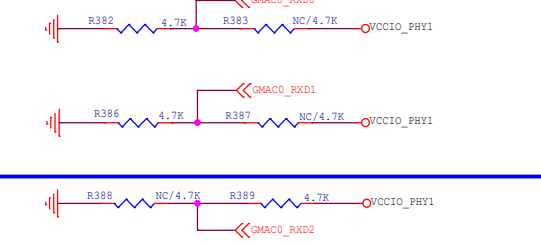
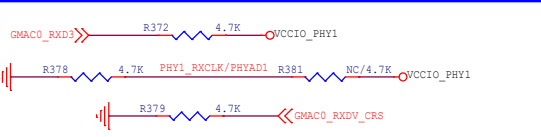
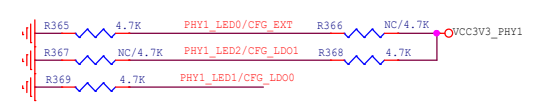
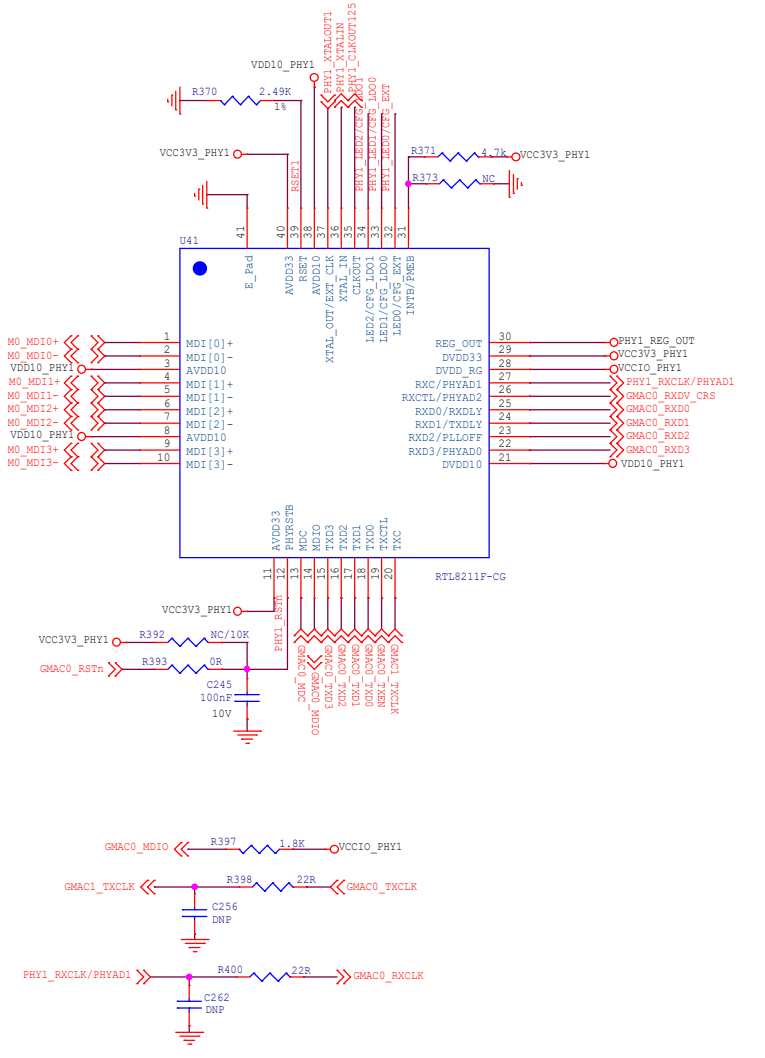
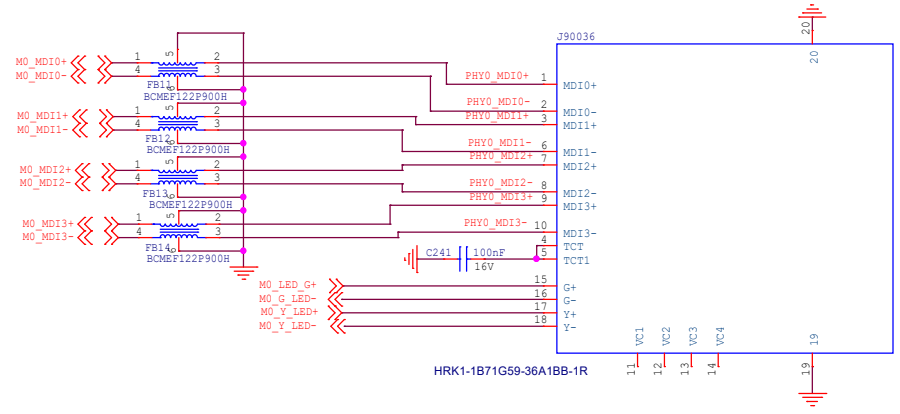
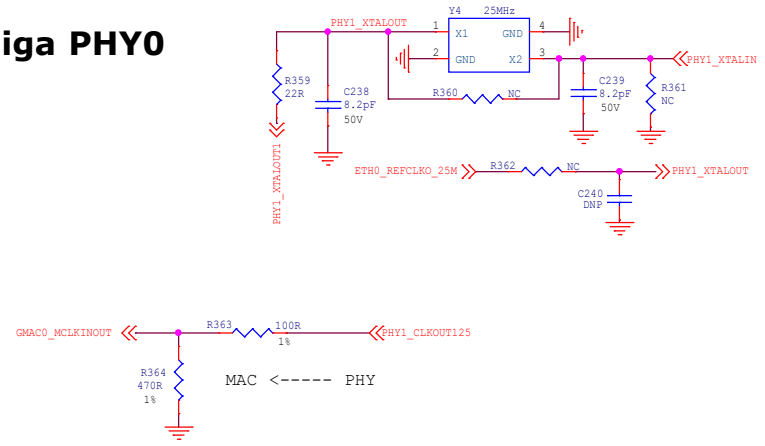

RGMIIPower Source	CFG_EXT	CFG_LD0[1:0]
External 3.3V	1'b1	2'b00
External 1.8V	1'b1	2'b10
Internal 1.8V(default)	1'b0	2'b10

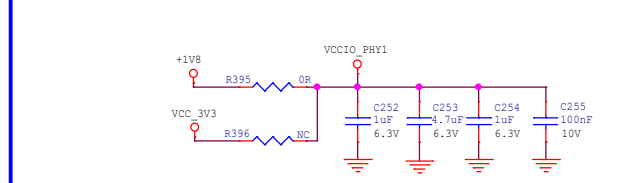
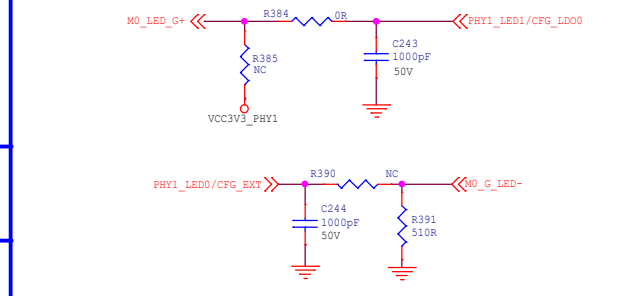
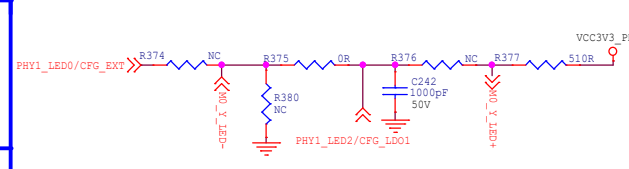



Size	Title: ROCK 3A	REV
A3	Page Name: Ethernet 1000MHz	V1.31
Date: Sunday, April 23, 2023	Sheet 1 of 25	

Revision History

Version	Date	By	Change Description	Approved
V1.0	2022-04			



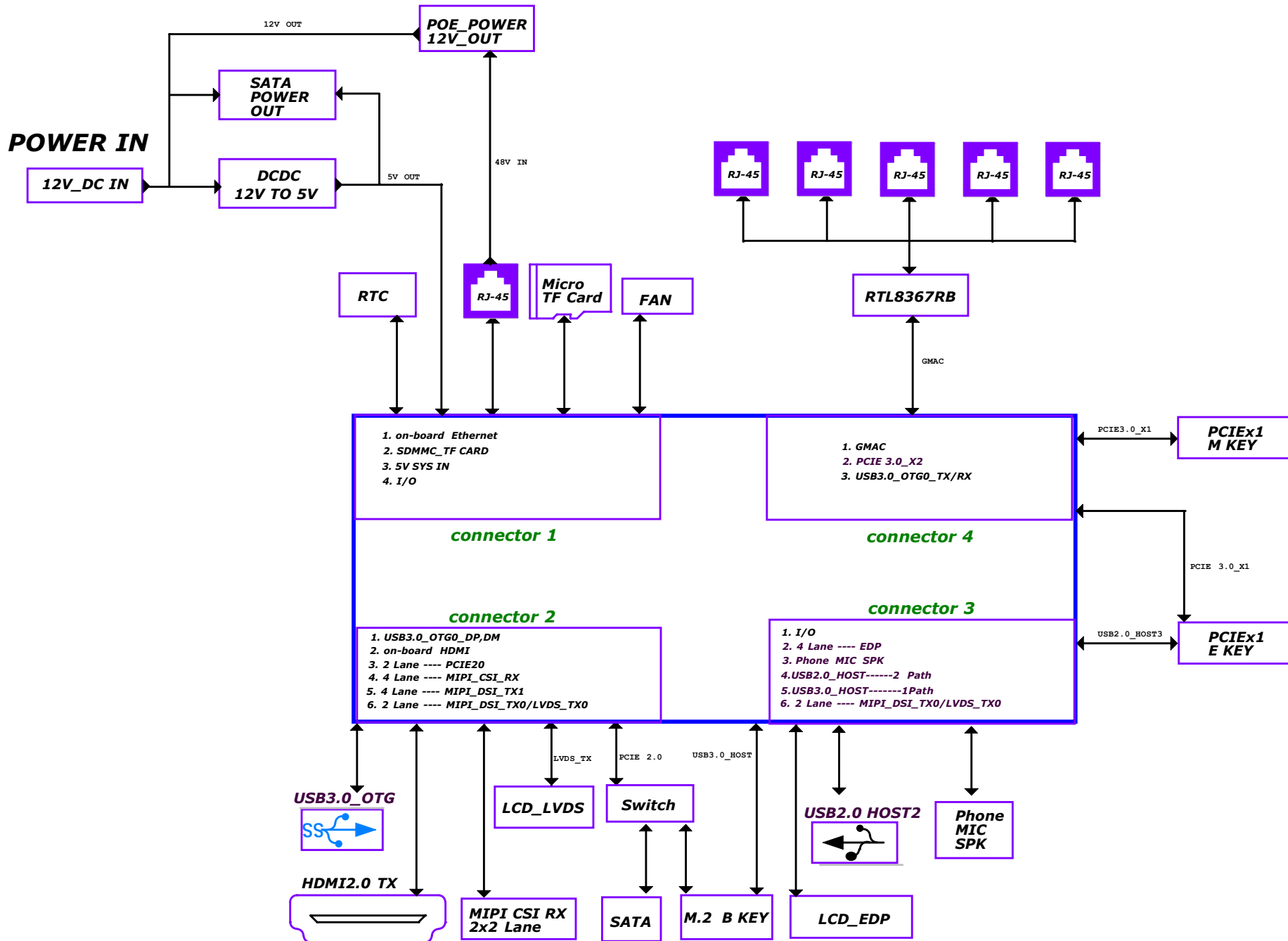

RS232

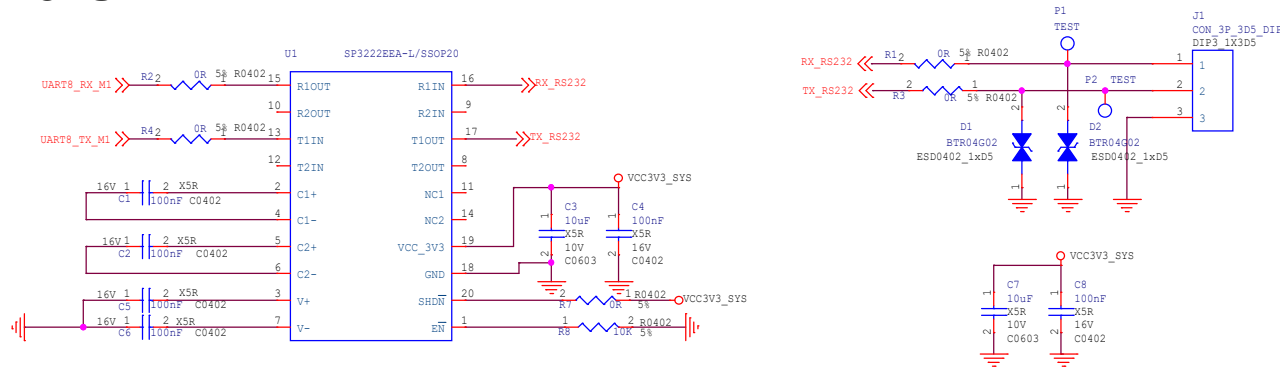

RS485

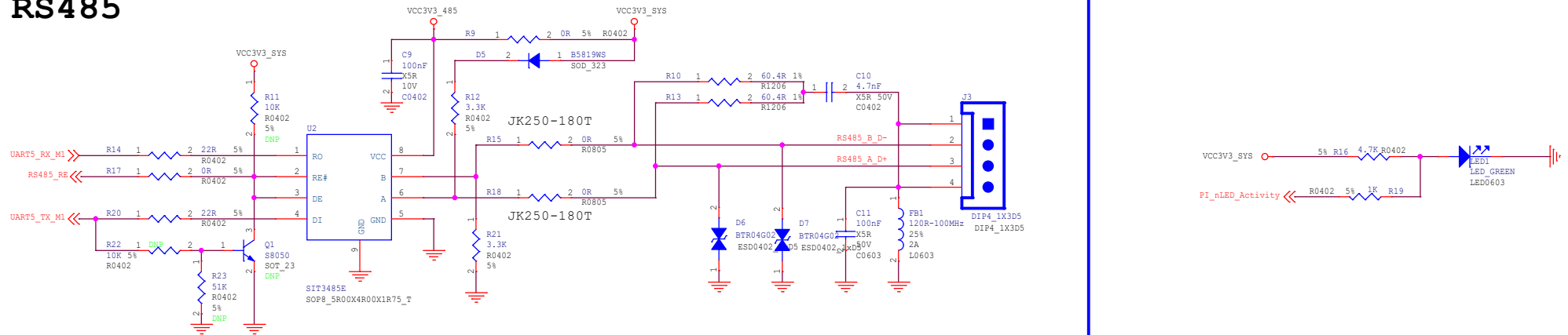

CAN

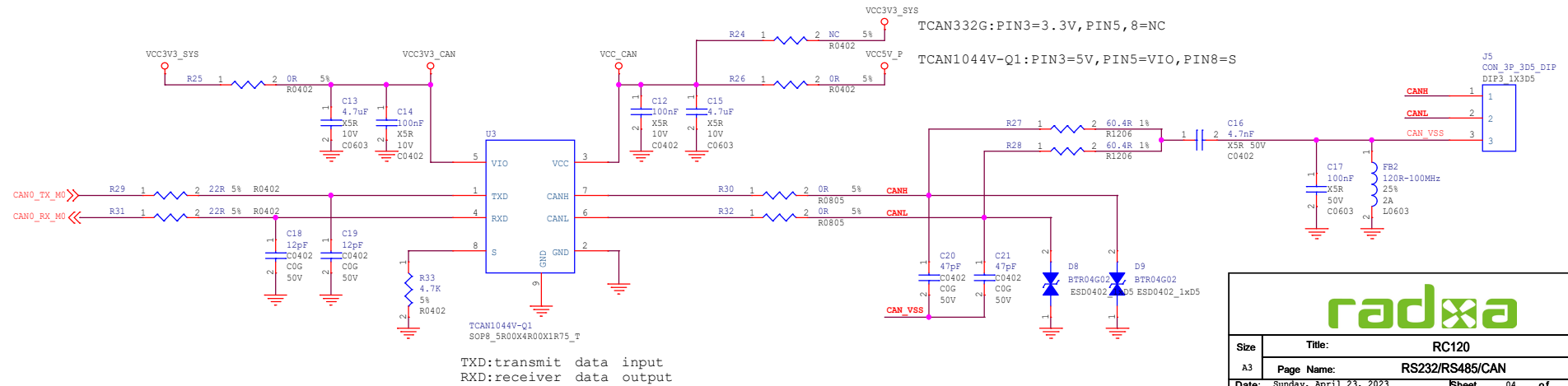

Size	Title:	RC120	REV
A3	Page Name:	RS232/RS485/CAN	V1.0
Date:	Sunday, April 23, 2023	Sheet	04 of 27

KEY B

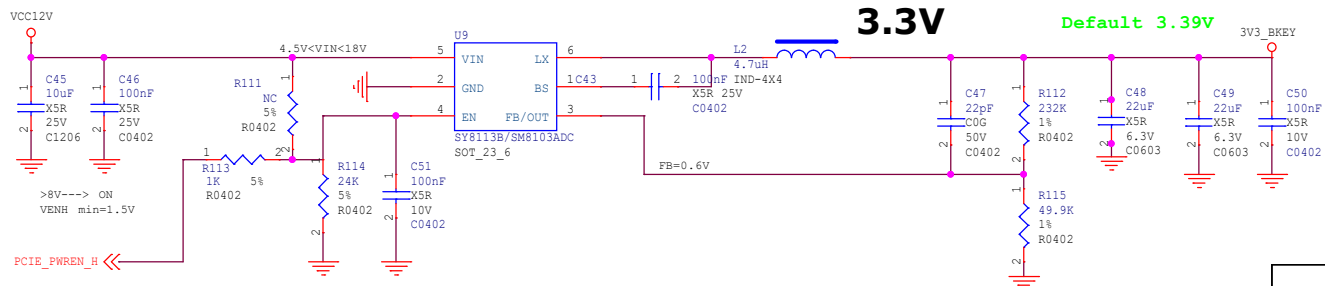
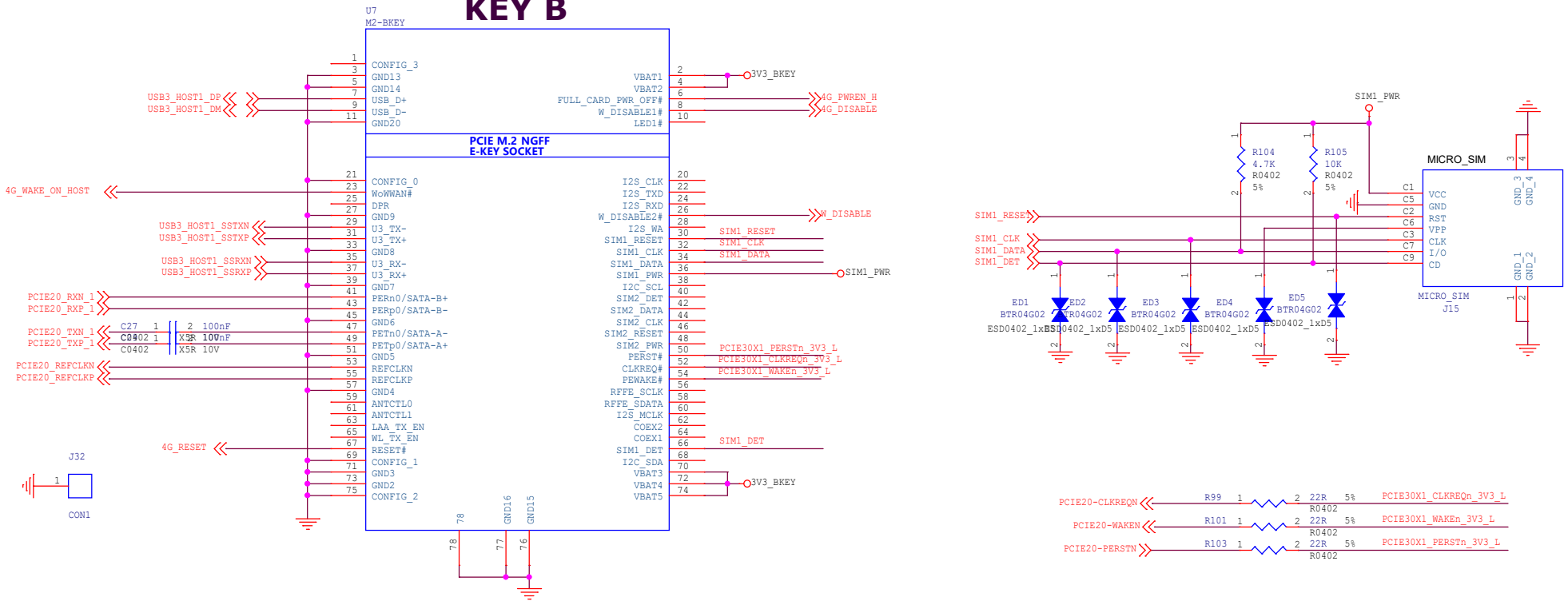

Size	Title:	RC120	REV
B	Page Name:	M.2 B KEY	V1.0
Date:	Sunday, April 23, 2023	Sheet	08 of 27

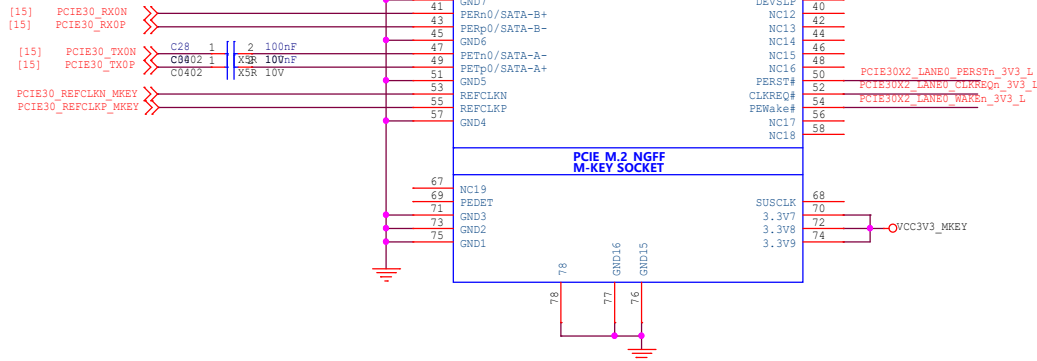
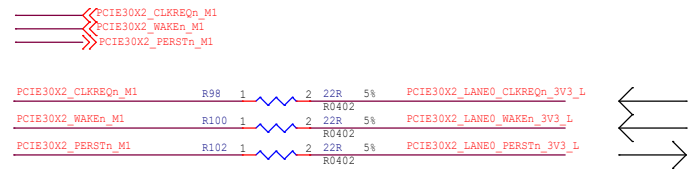
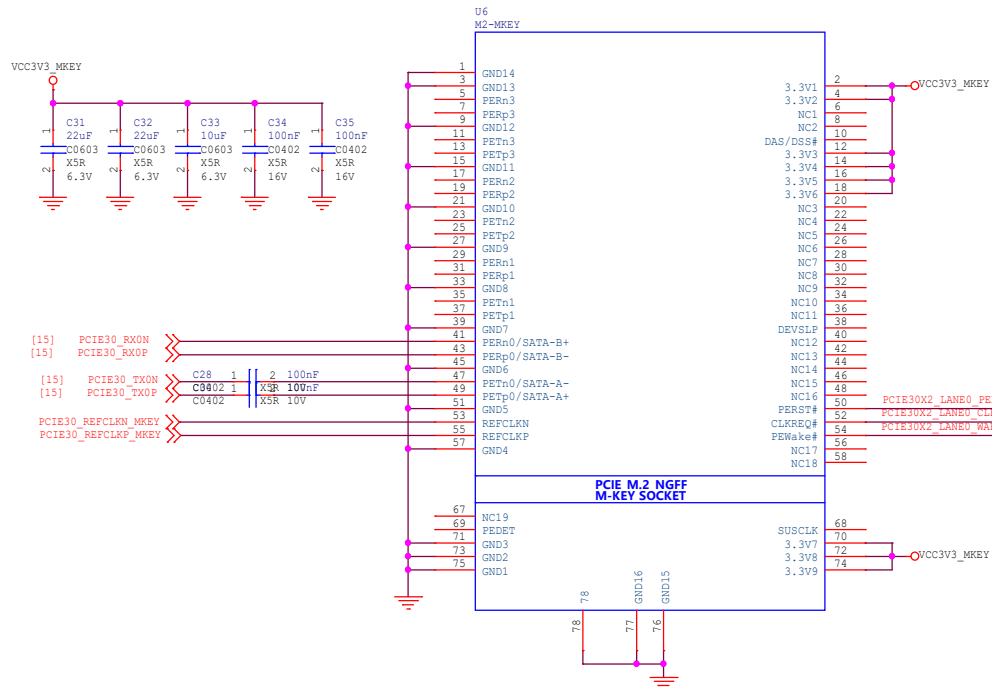

3.3V Default 3.39V

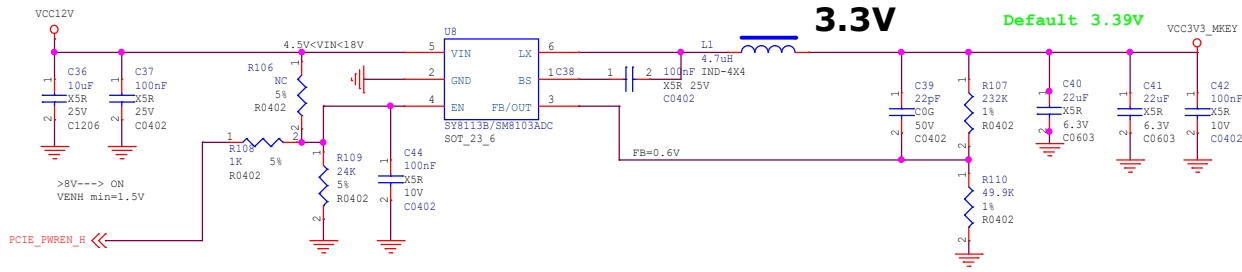

SDIO WIFI/BT MODULE

WIFI NGFF/M.2

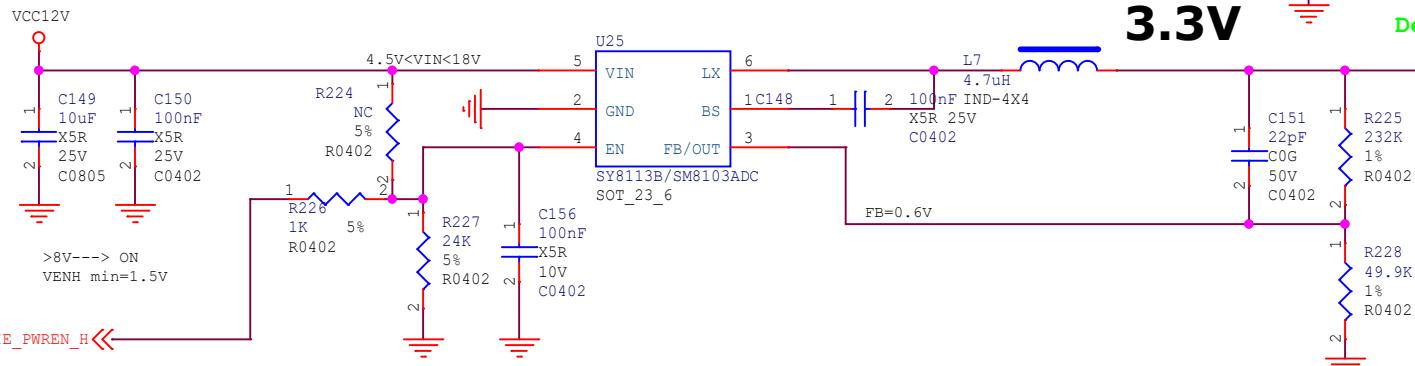
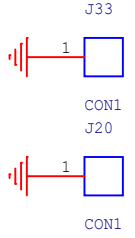
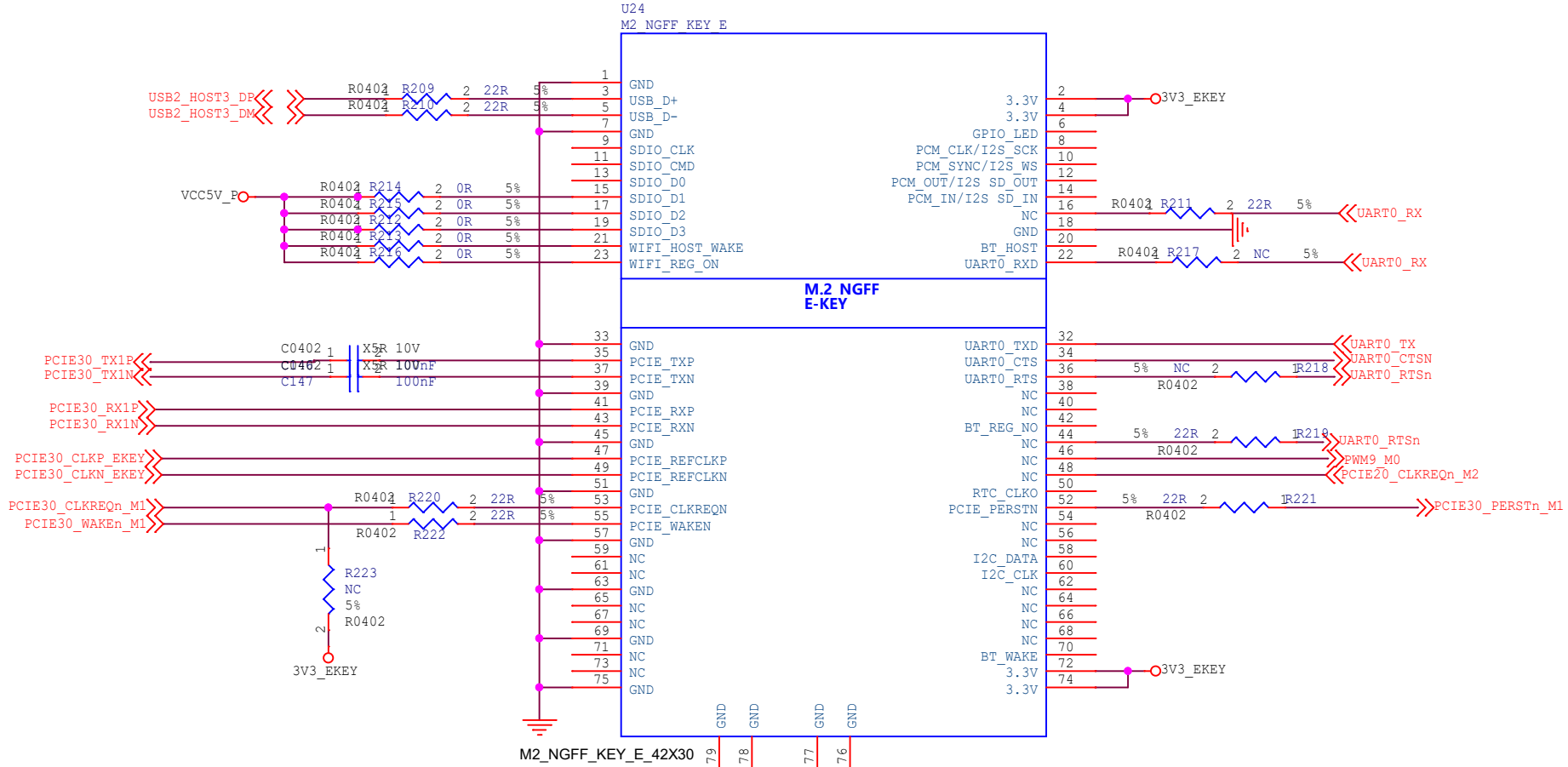

Size	Title:	RC120	REV
A4	Page Name:	M.2 E KEY	V1.0
Date:	Sunday, April 23, 2023	Sheet	10 of 27

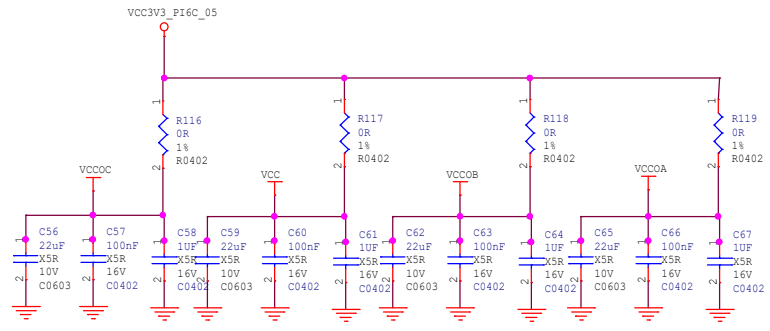
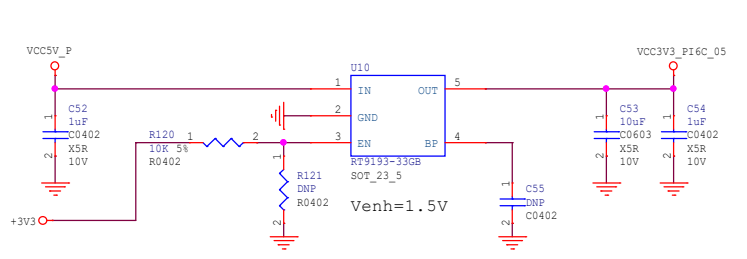

```

CLKOUT_Type1 CLKOUT_Type0 CLK Buffer Type
0 0 LVPECL
0 1 LVDS
1 0 HCSL
1 1 HZ

CLKin_SEL[1] CLKin_SEL[0] Selected Clock
0 0 CLKIN0, CLKIN1*
0 1 CLKIN1, CLKIN1*
1 0 Crystal
Or
Crystal bypass AC
coupled mode
1 1 Crystal bypass DC
coupled mode
  
```

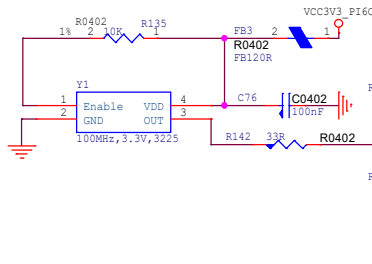
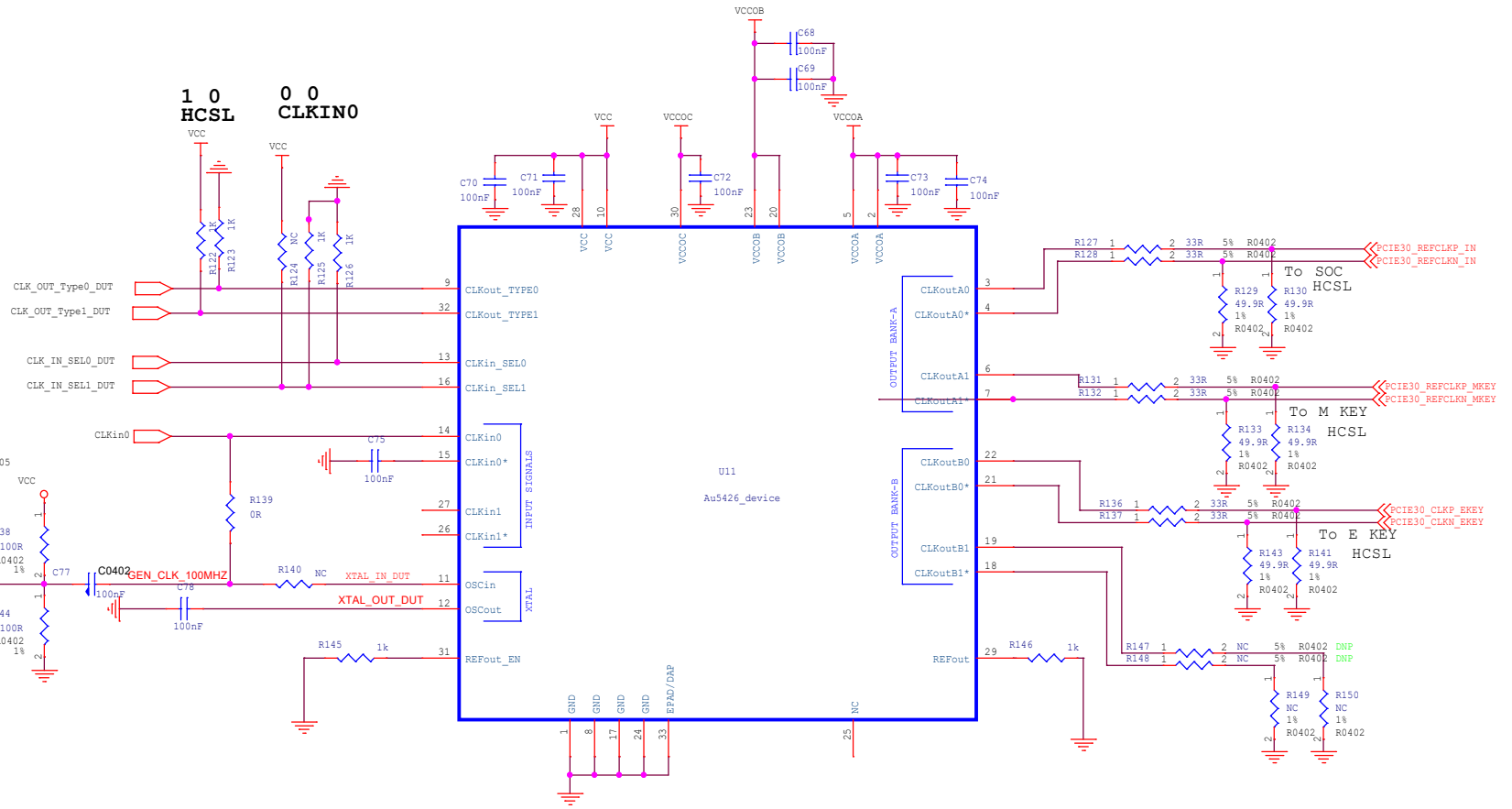

Size	Title:	RC120	REV
A3	Page Name:	PCIE_CLK	V1.0
Date:	Sunday, April 23, 2023	Sheet	11 of 27

SATA3.0 Port2

And PCIe2.0 option

NOTES:

- 1:The SATA differential trace impedance is 100 OHM.
- The SATA trace length is less than 5 inch.
- 2:10nF close to connector

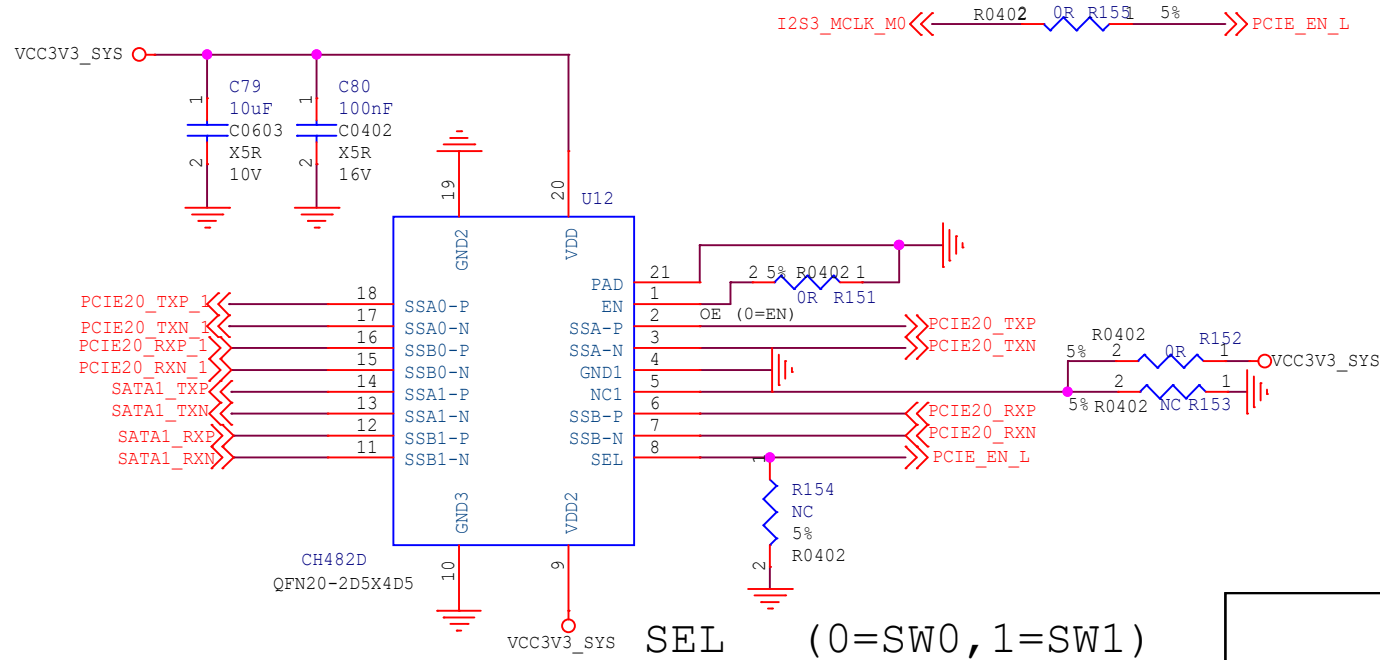
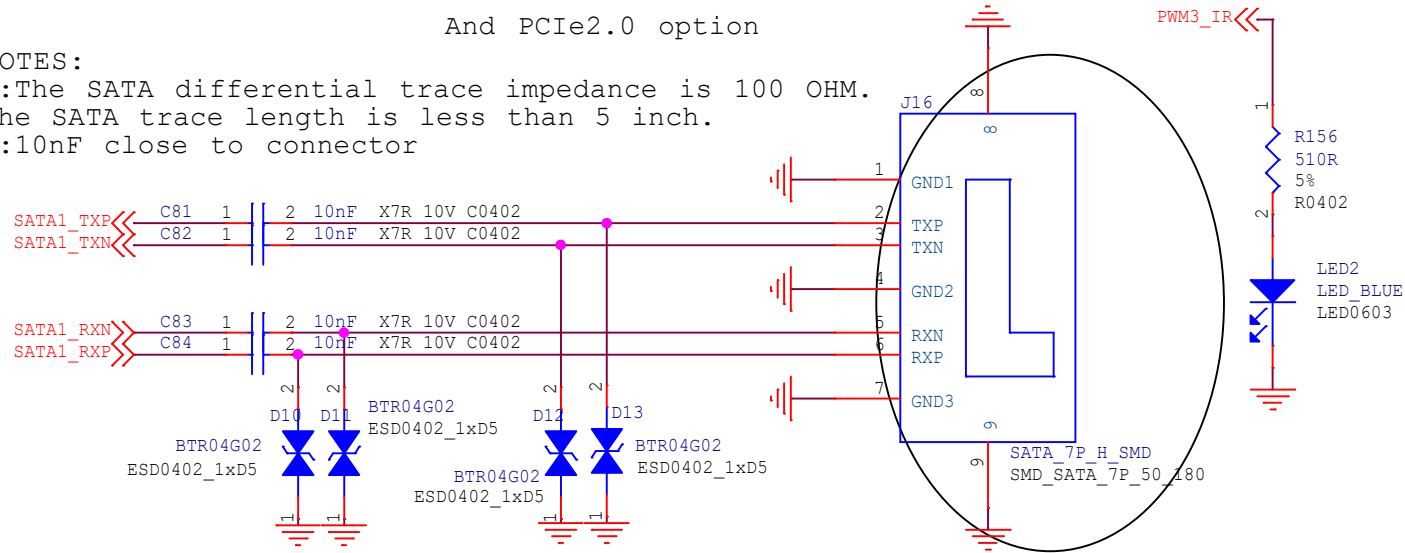

Size		Title:	RC120	REV
		Page Name:	SATA SW	
Date:		Sunday, April 23, 2023	Sheet	12 of 27

MIPI_CSI_RX 2Lanes

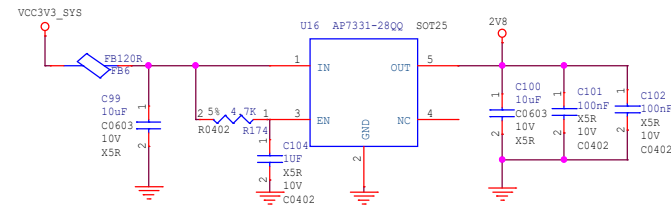
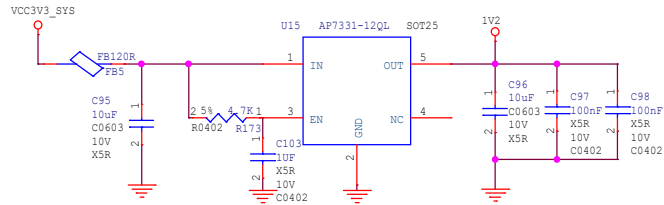
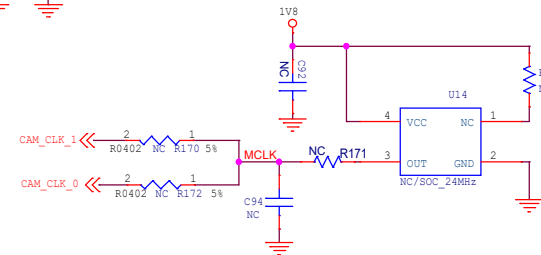
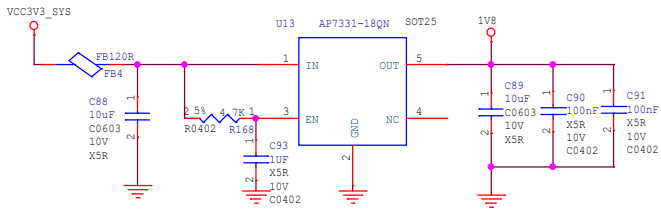
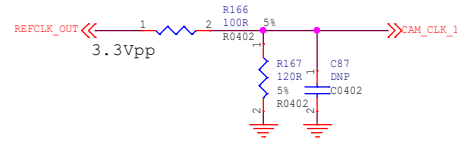
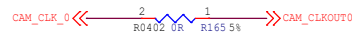
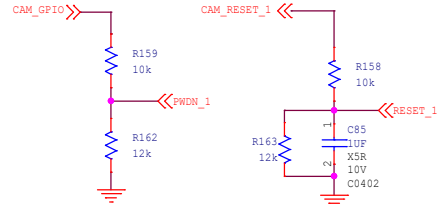
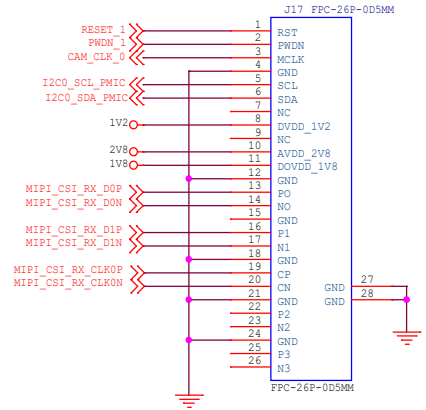

MIPI_CSI_RX 2Lanes

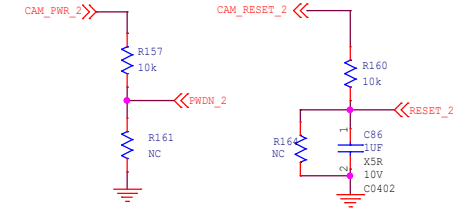
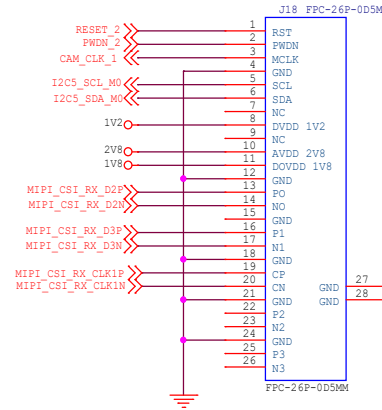

EDP40PIN

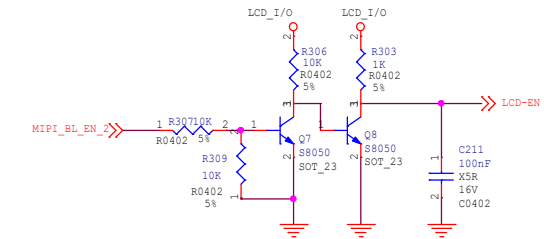
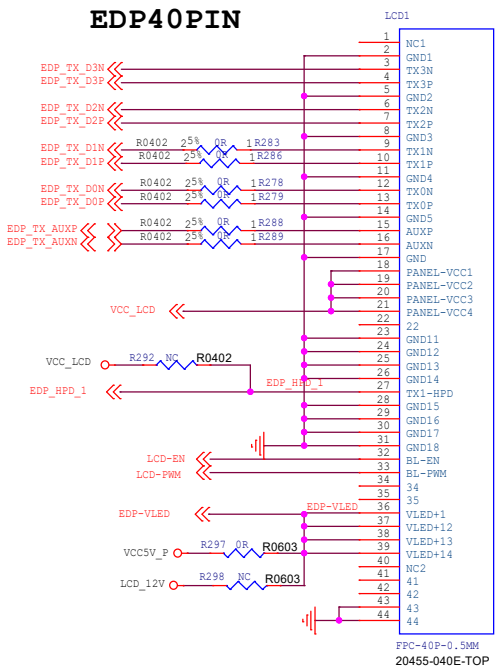

EDP30PIN

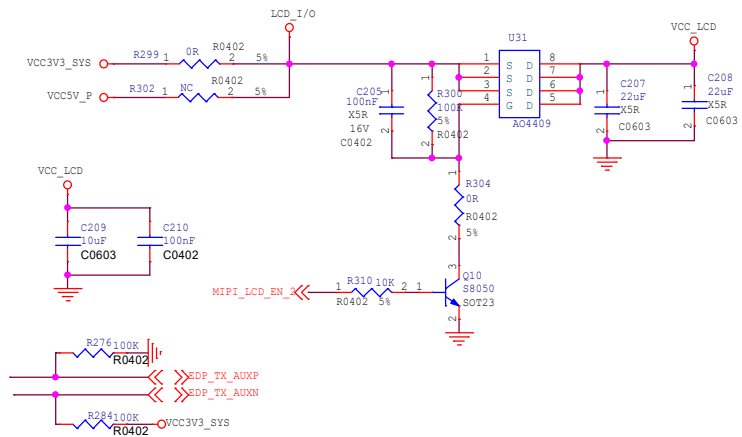
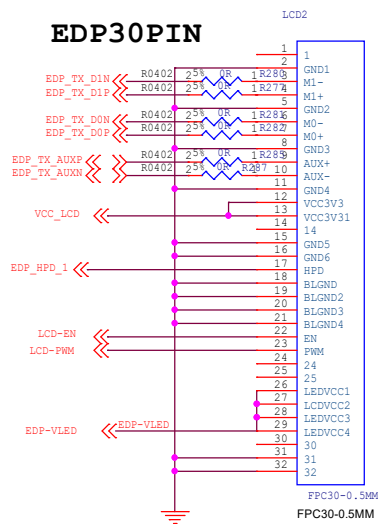

LCD_TP

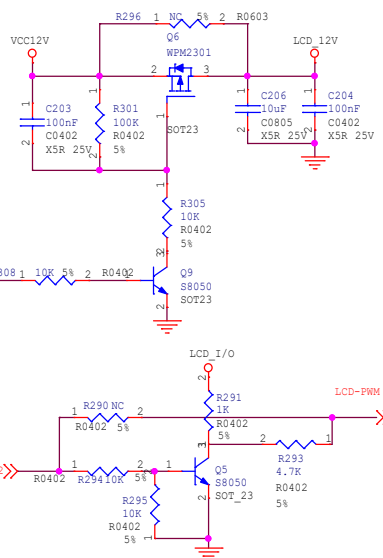
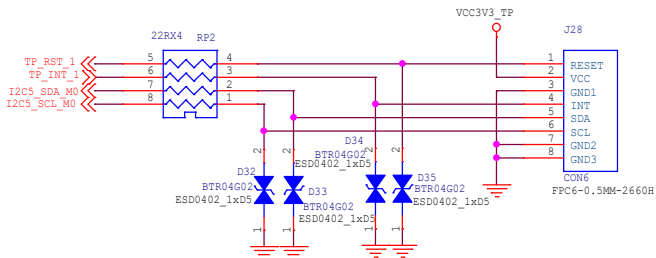
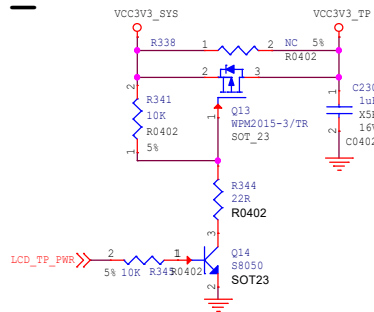

Size	Title:	RC120	REV
A3	Page Name:	EDP_LCD	V1.0
Date:	Sunday, April 23, 2023	Sheet	14 of 27

LVDS_LCD_TX0

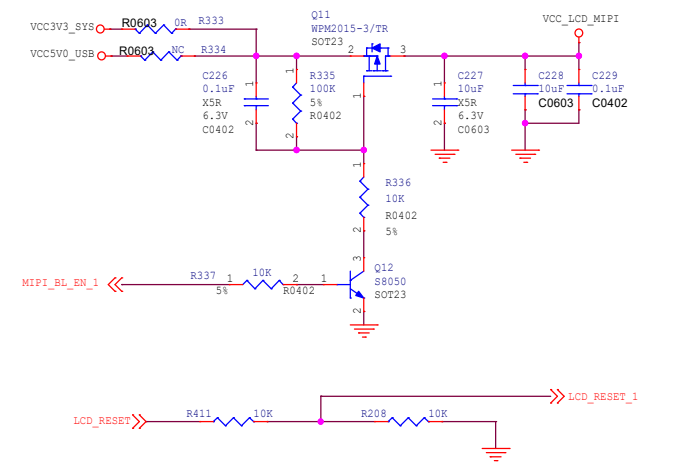
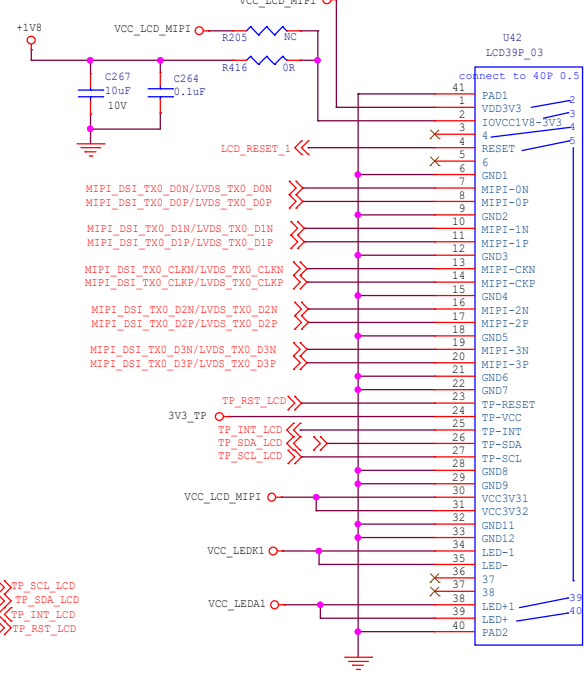
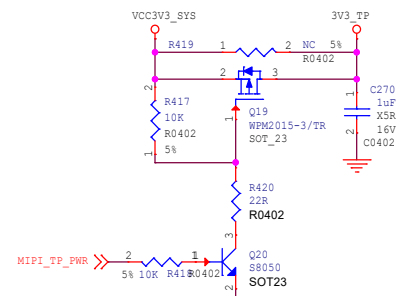
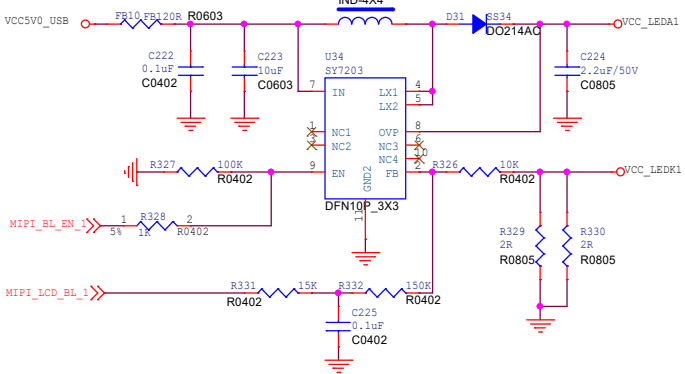

LCD_TP

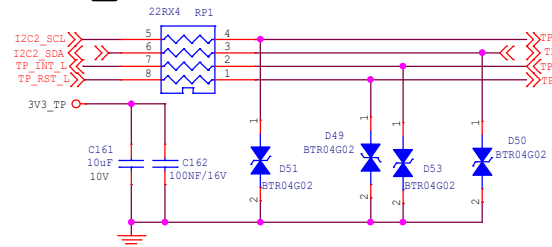

Size	Title:	RC120
A3	Page Name:	LVDS_LCD
Date: Sunday, April 23, 2023	Sheet	15 of 27
	REV	V1.0

MicroSD Card

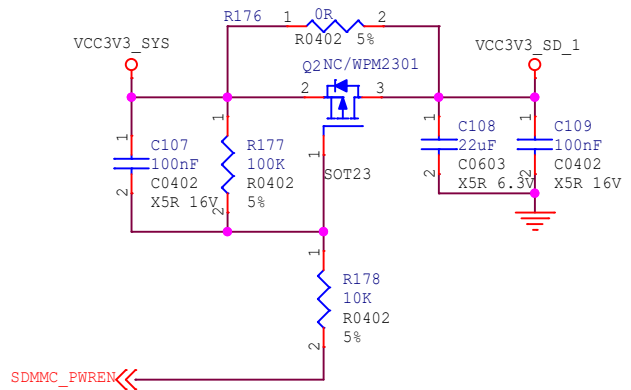
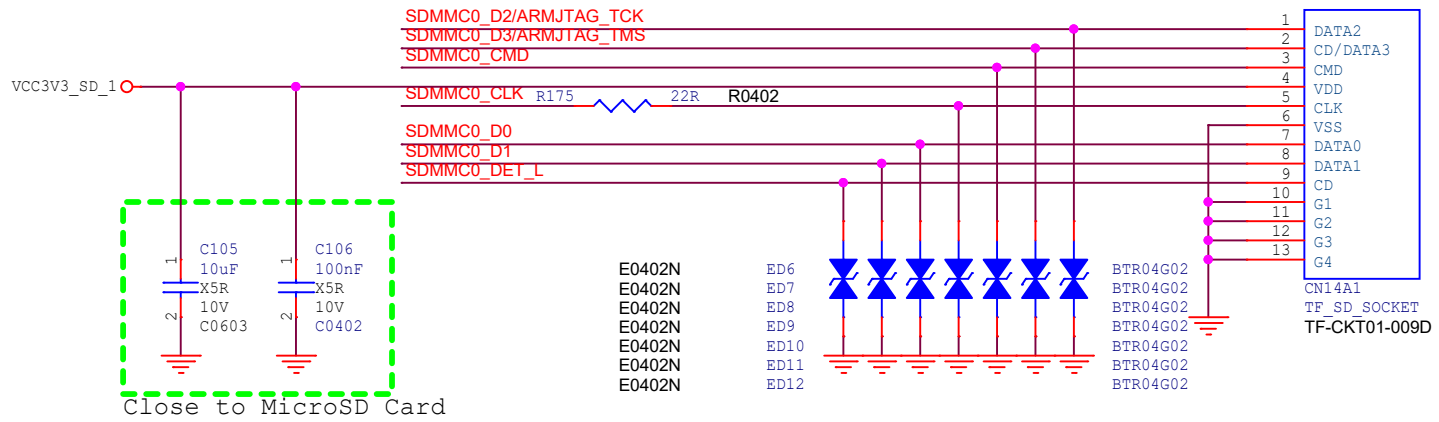
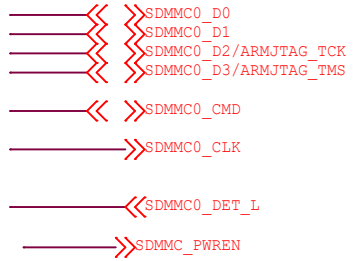

Size	Title: RC120	REV
A4	Page Name: MicroSD Card	V1.0
Date: Sunday, April 23, 2023	Sheet 16 of 27	

HDMI2.0 TX

$C_j \leq 0.4 \text{ pF}$

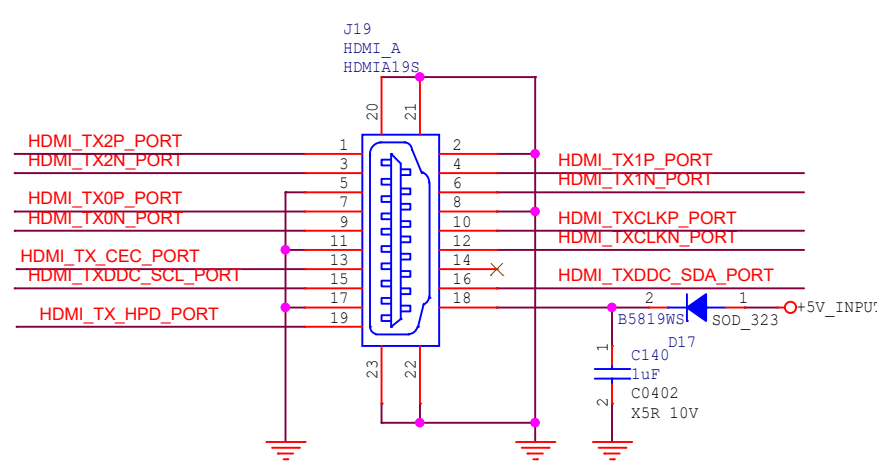
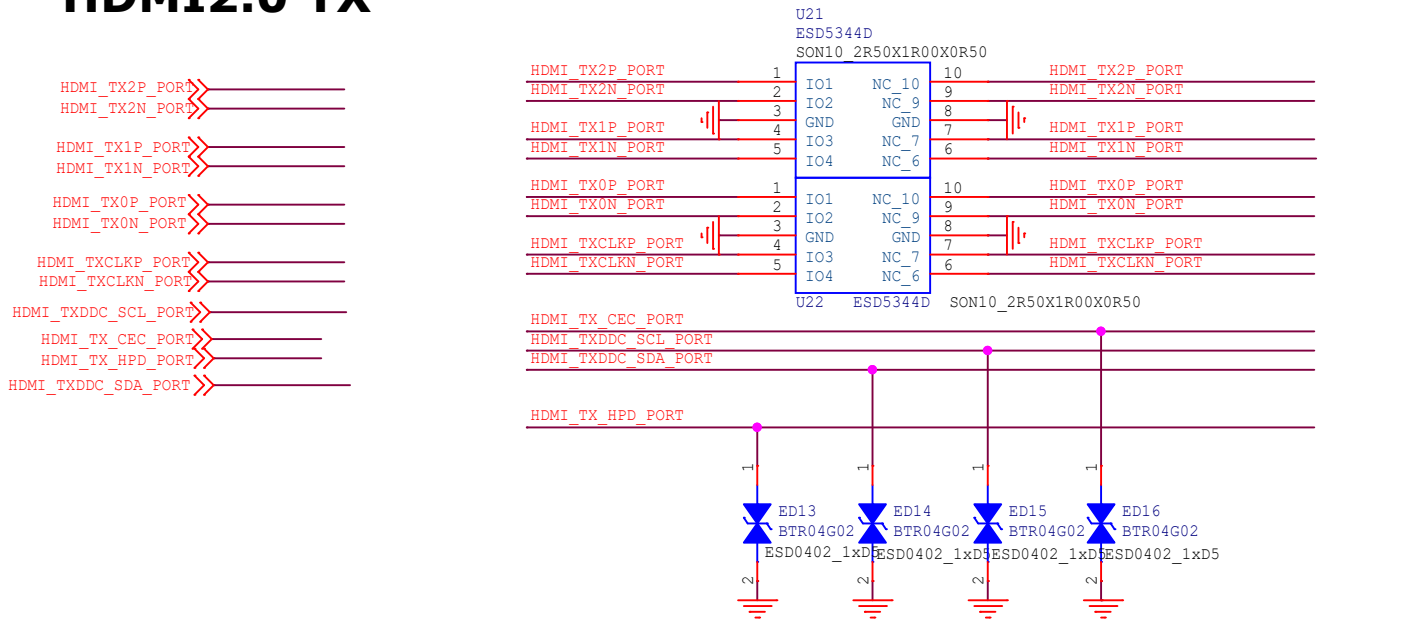

Size	Title:	RC120	REV
A4	Page Name:	HDMI OUT	V1.0
Date:		Sunday, April 23, 2023	Sheet 17 of 27

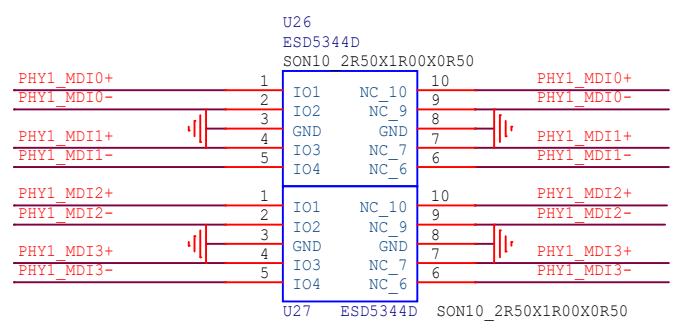
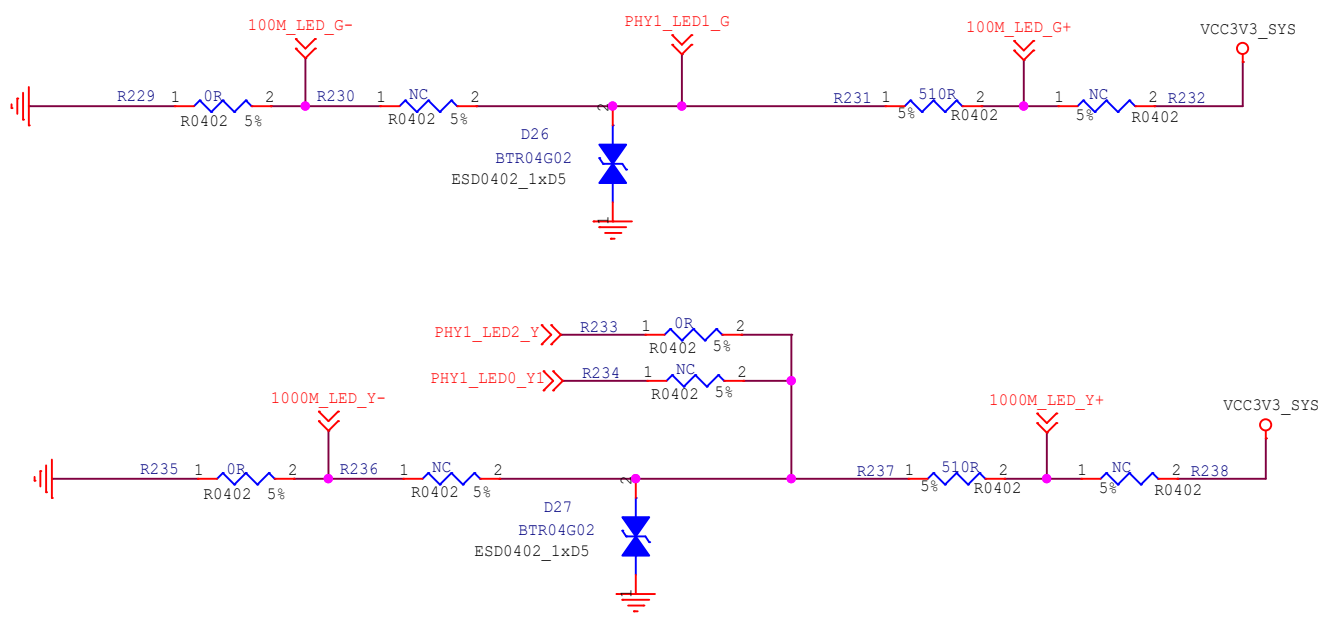
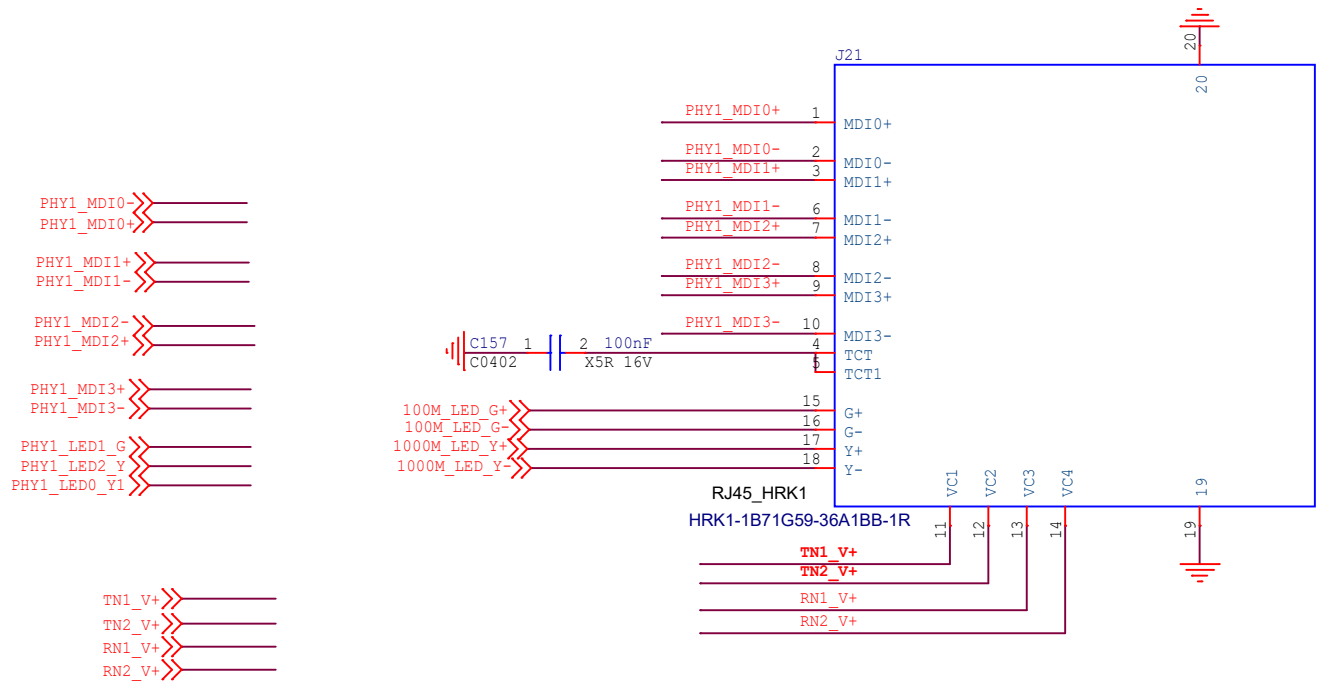

radxa

Size	Title:	RC120	REV
A4	Page Name:	Ethernet_1000M	V1.0
Date:		Sunday, April 23, 2023	Sheet 18 of 27

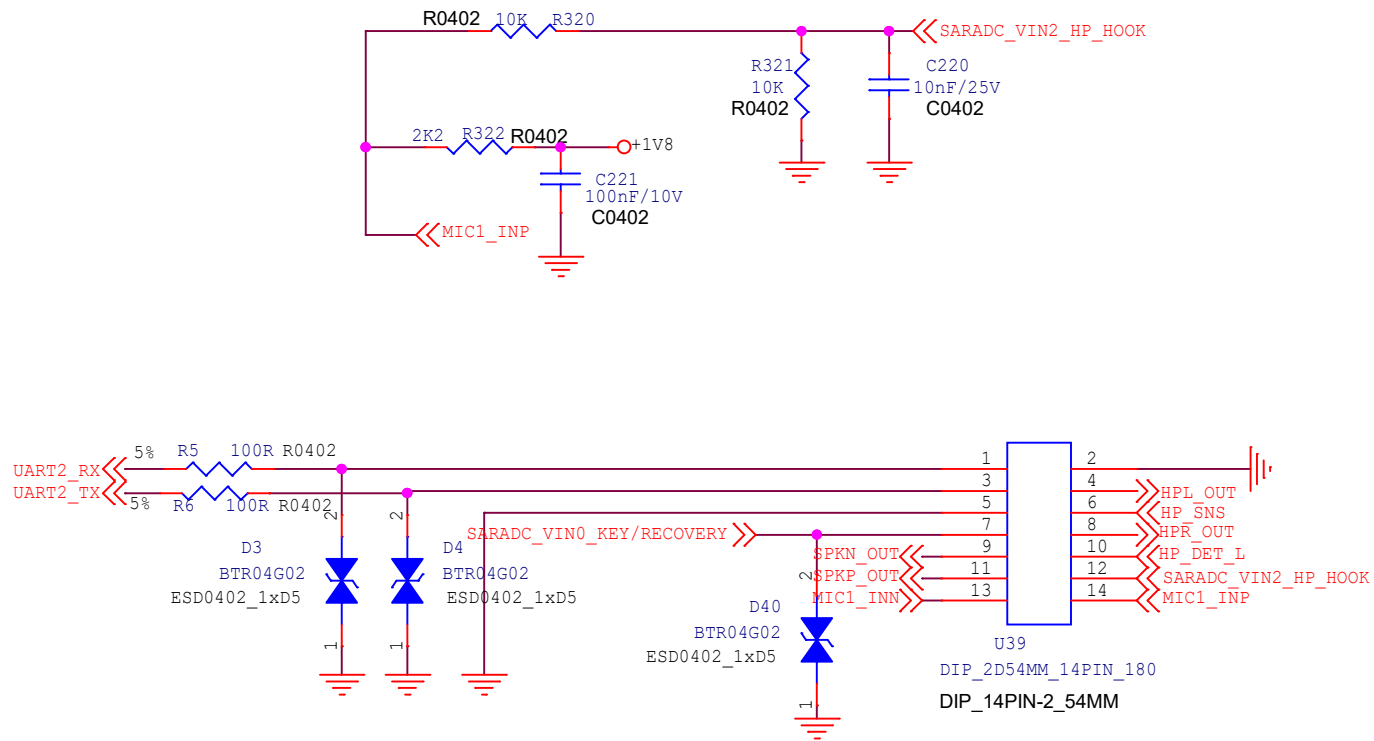

radxa		
Size	Title: RC120	REV
A	Page Name: AUDIO/UART	V1.0
Date: Sunday, April 23, 2023	Sheet 19 of 27	

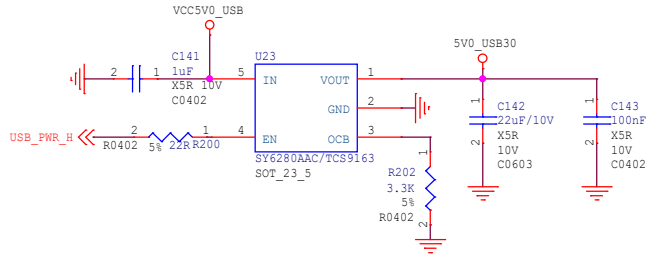
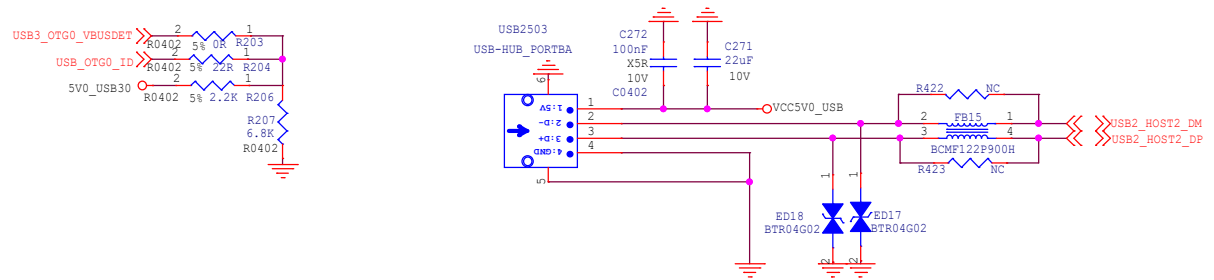
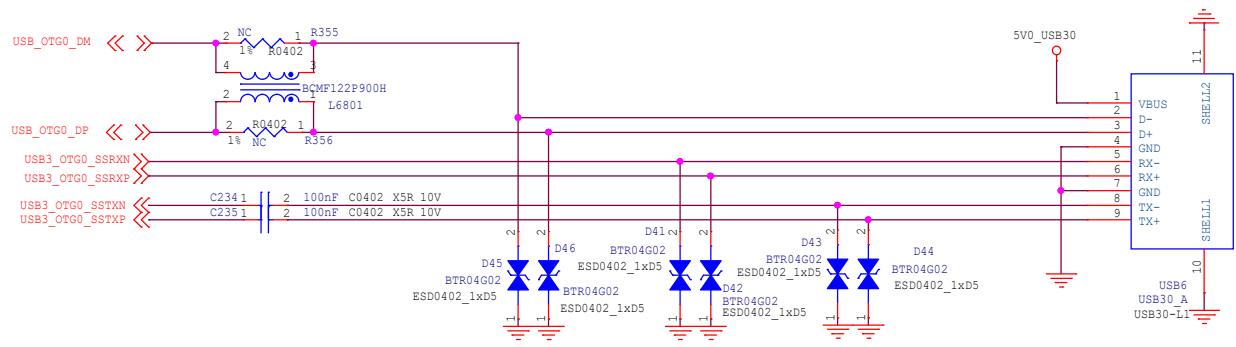

Size	Title:	RC120	REV
B	Page Name:	USB OTG/HOST	V1.0
Date:	Sunday, April 23, 2023	Sheet	20 of 27

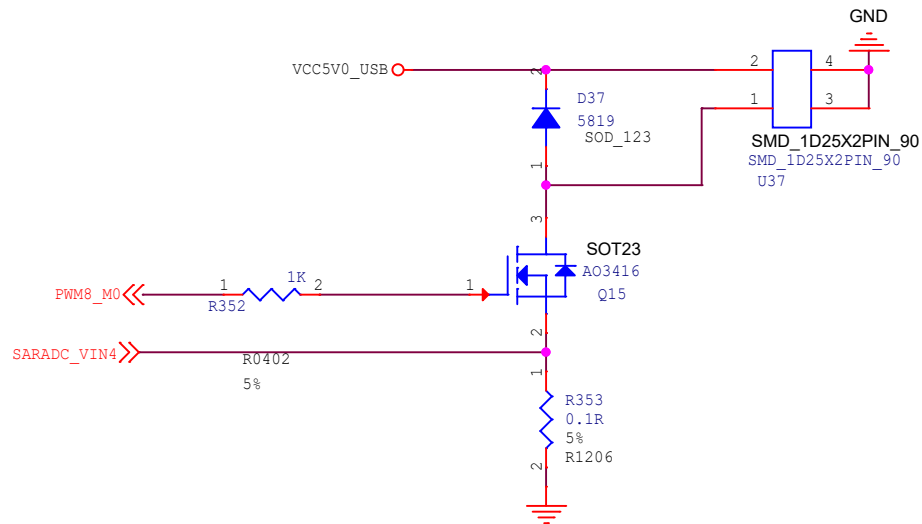
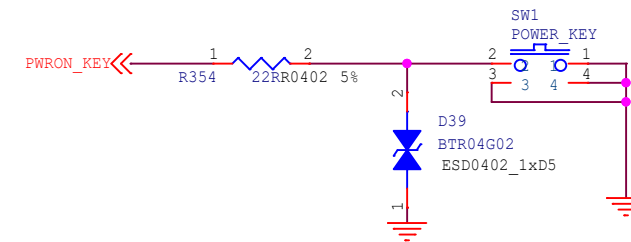
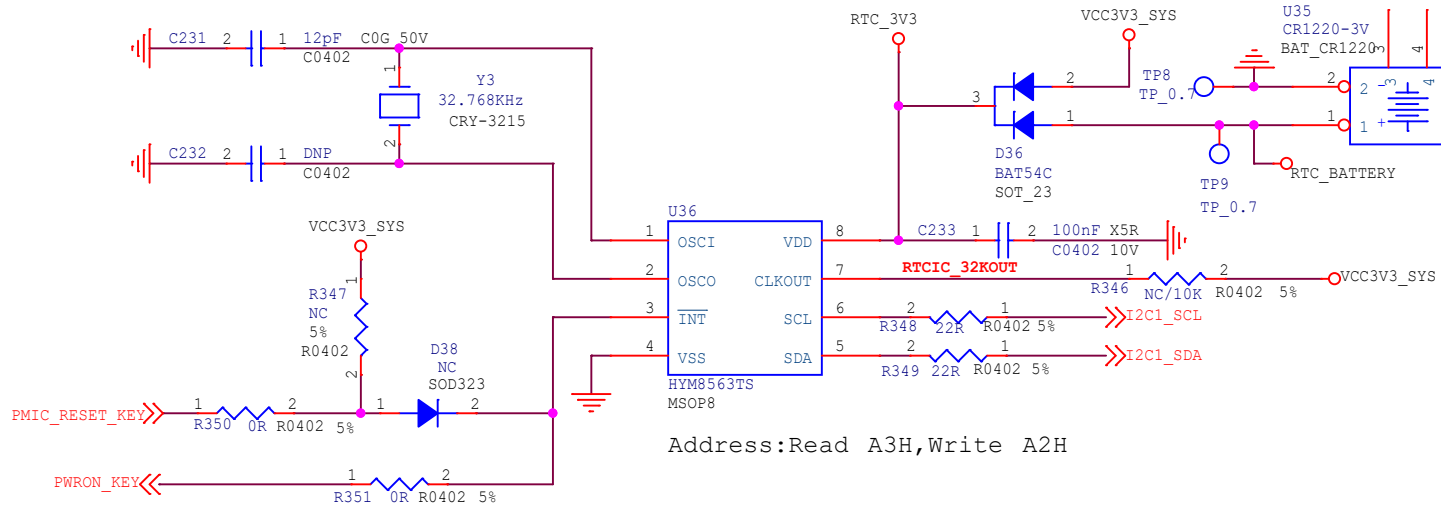

Size	Title:	RC120	REV
A4	Page Name:	FAN_RTC_KEY	V1.0
Date:		Sunday, April 23, 2023	Sheet 21 of 27

DC IN&SYSTEM Power

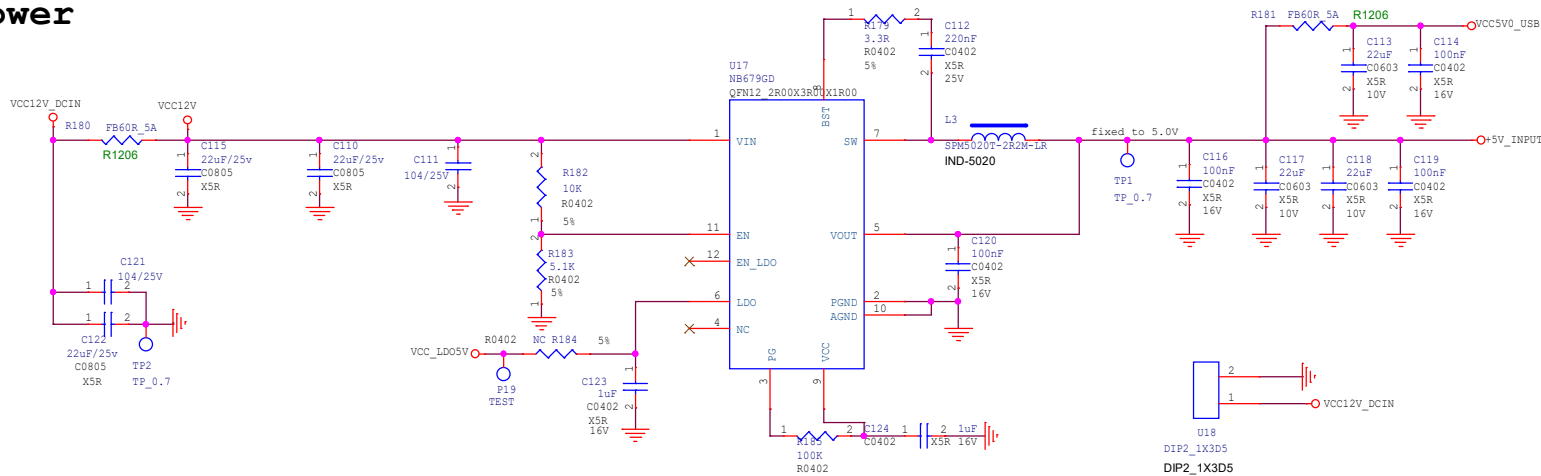

DC12V

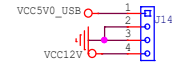
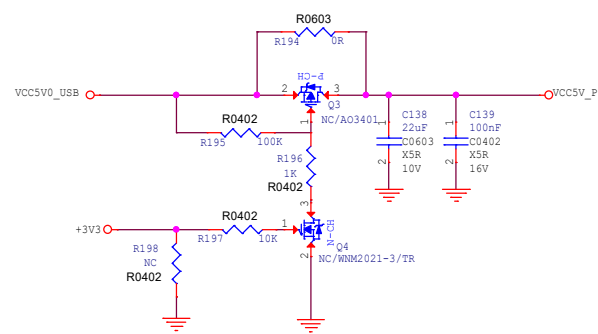
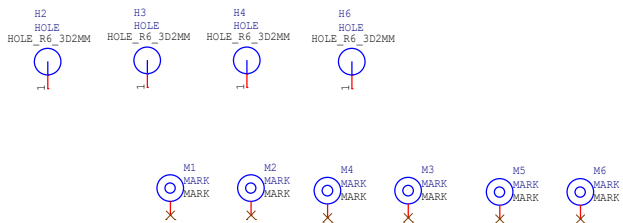
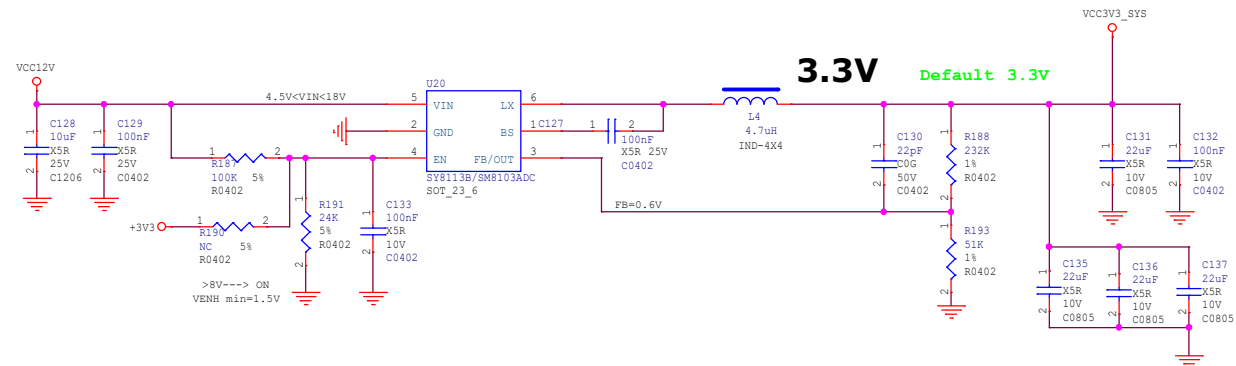
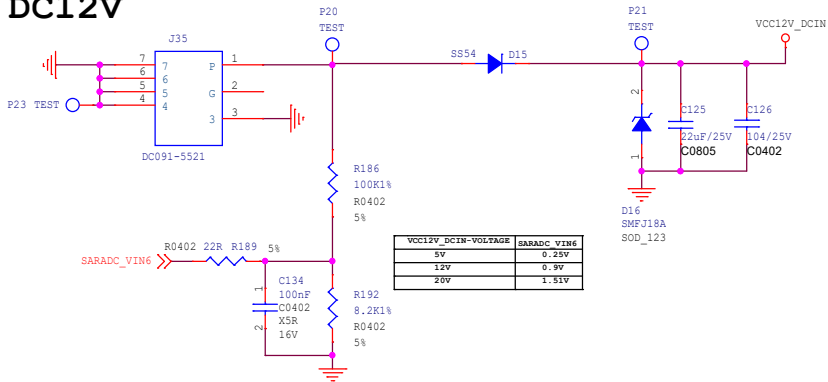

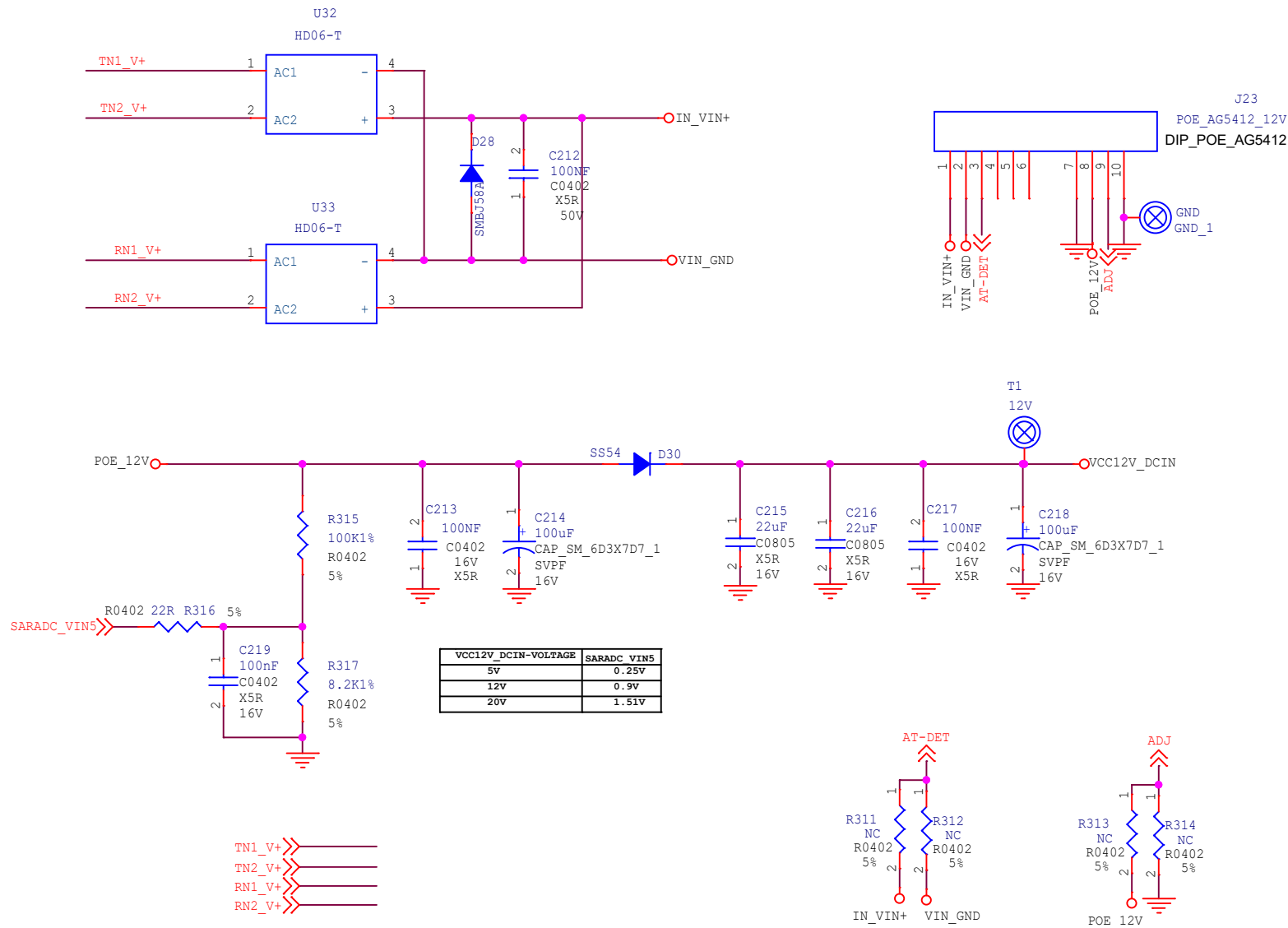

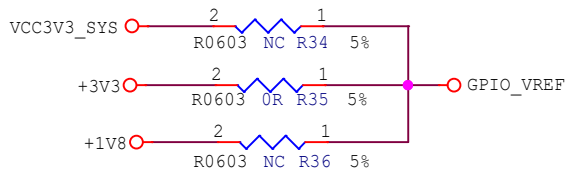
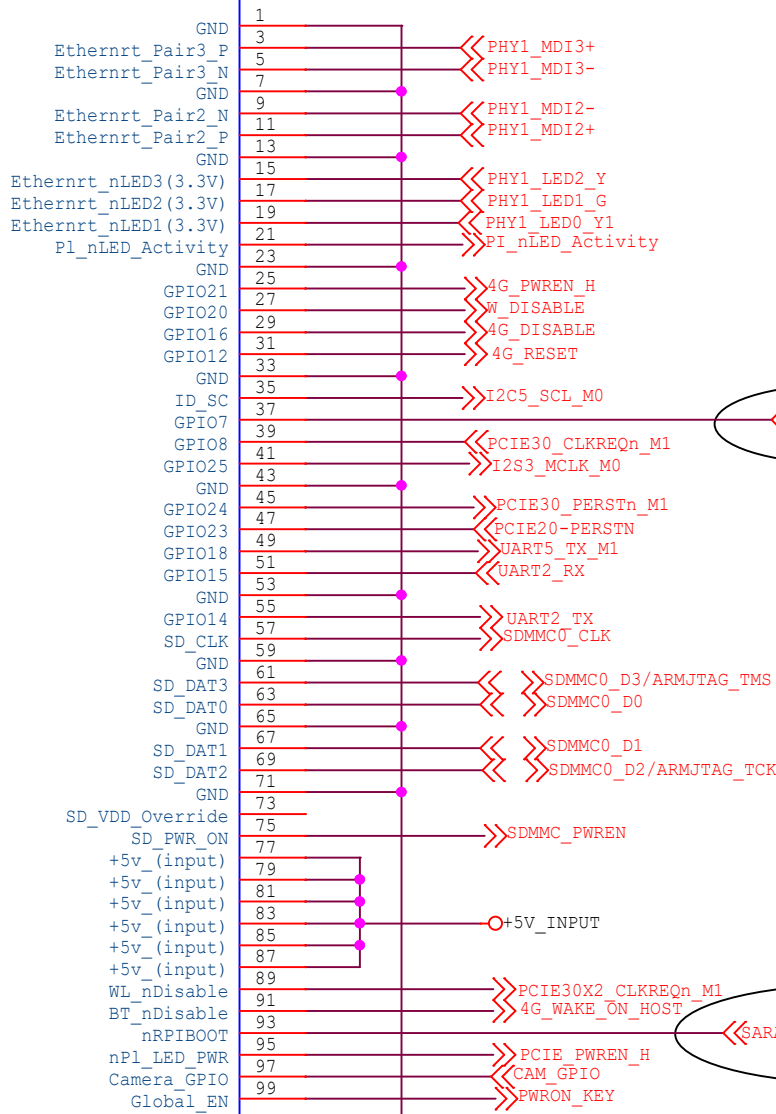
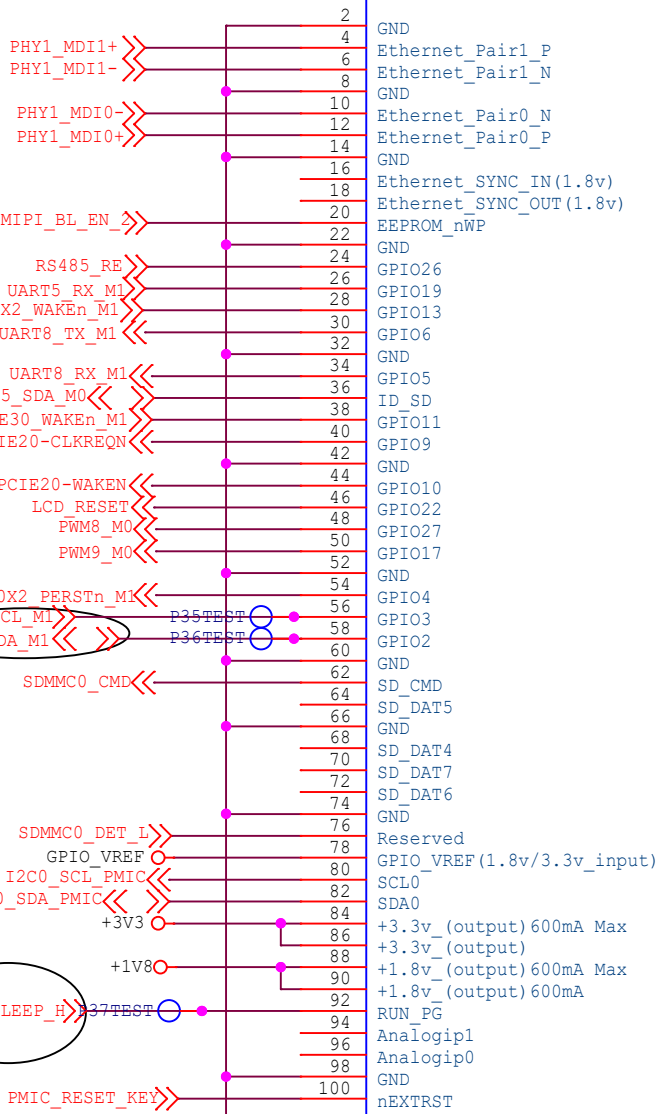

Size	Title: RC120	REV
A	Page Name: GPIO+VCC_Connector	V1.0
Date: Sunday, April 23, 2023	Sheet 24 of 27	

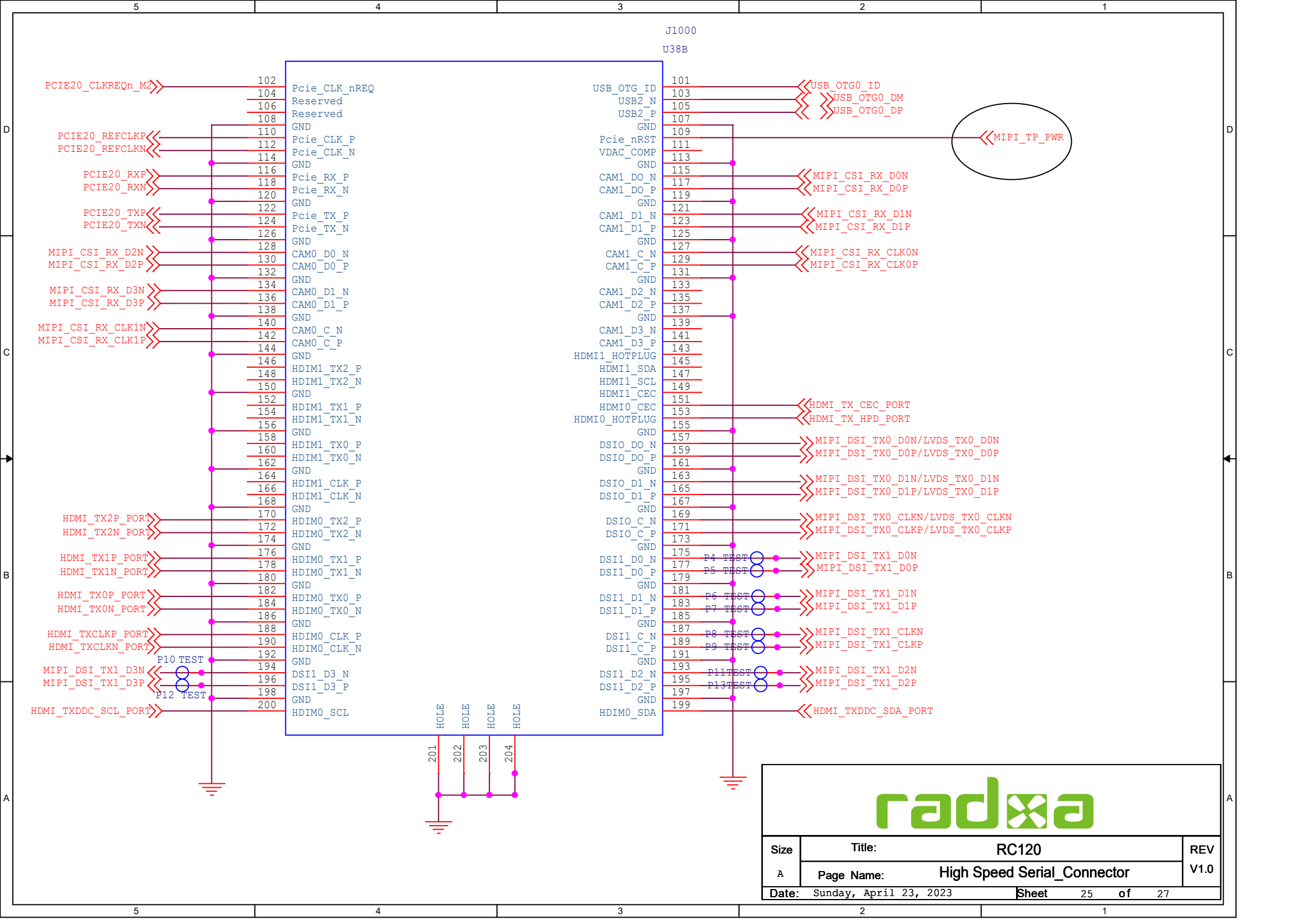

Size	Title: RC120	REV
A	Page Name: High Speed Serial_Connector	V1.0
Date: Sunday, April 23, 2023	Sheet 25 of 27	

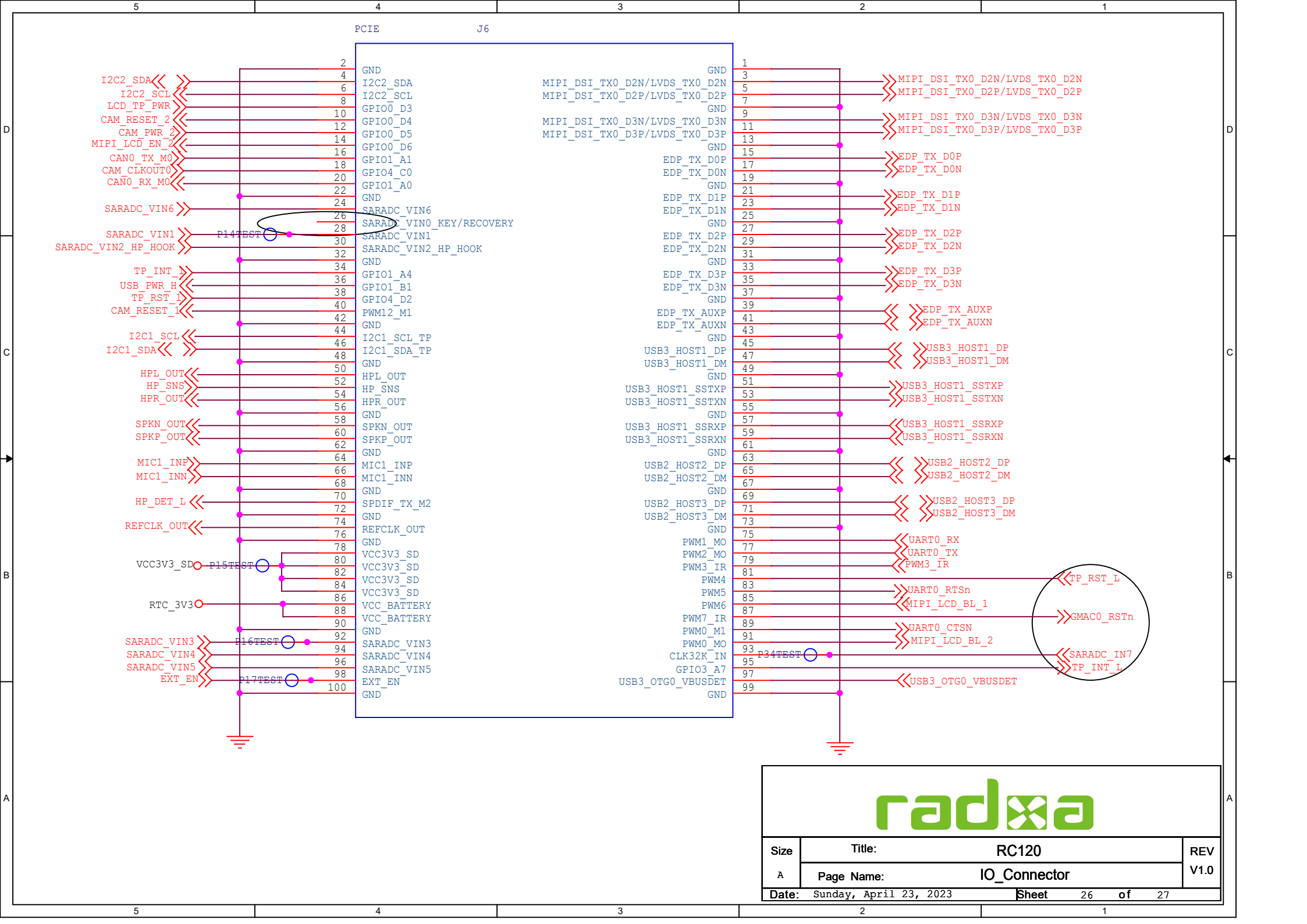

Size	Title: RC120	REV
A	Page Name: IO_Connector	V1.0
Date: Sunday, April 23, 2023		Sheet 26 of 27

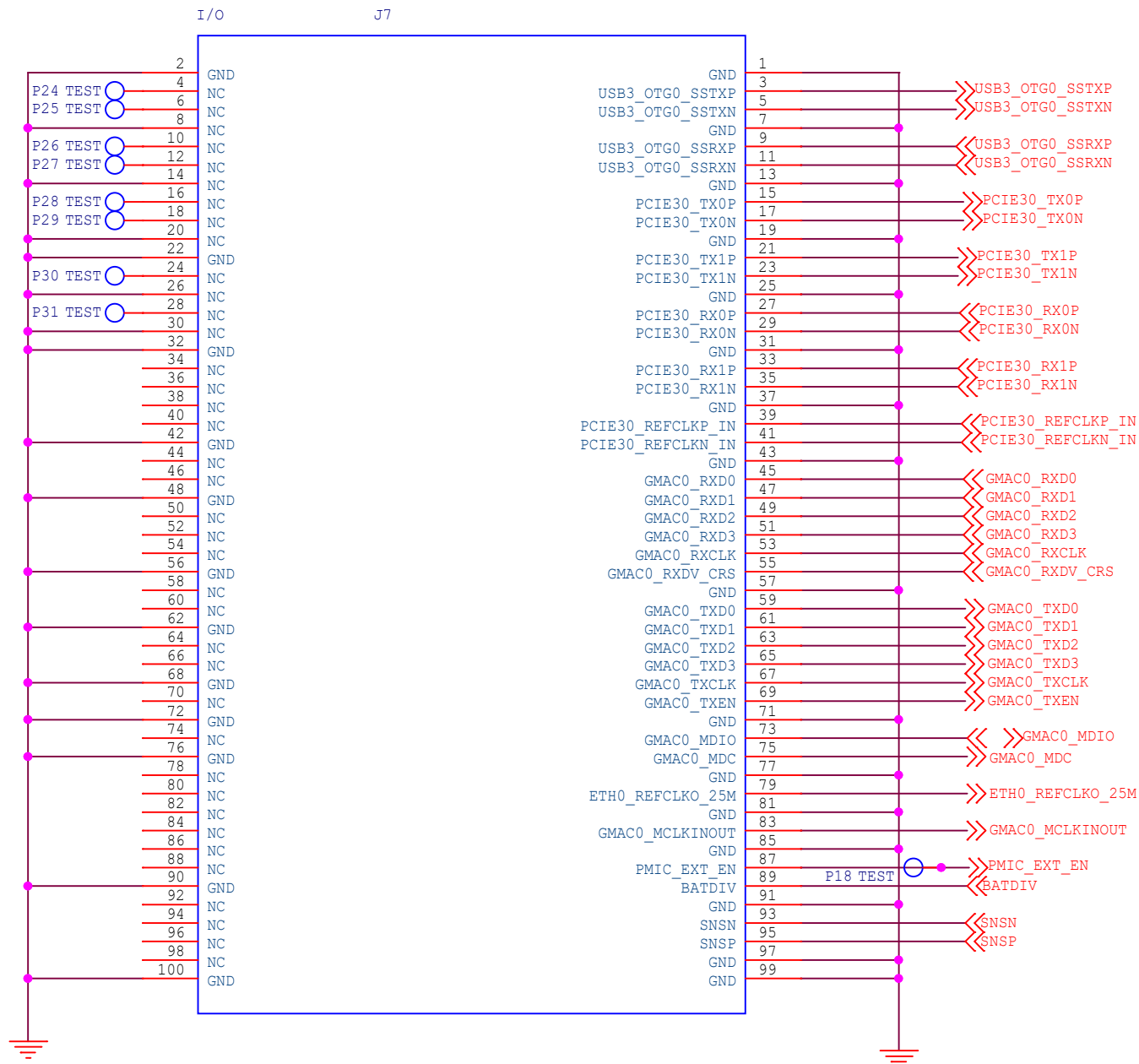

Size	Title: RC120	REV
A	Page Name: IO2_Connector	V1.0
Date: Sunday, April 23, 2023	Sheet 27 of 27	