

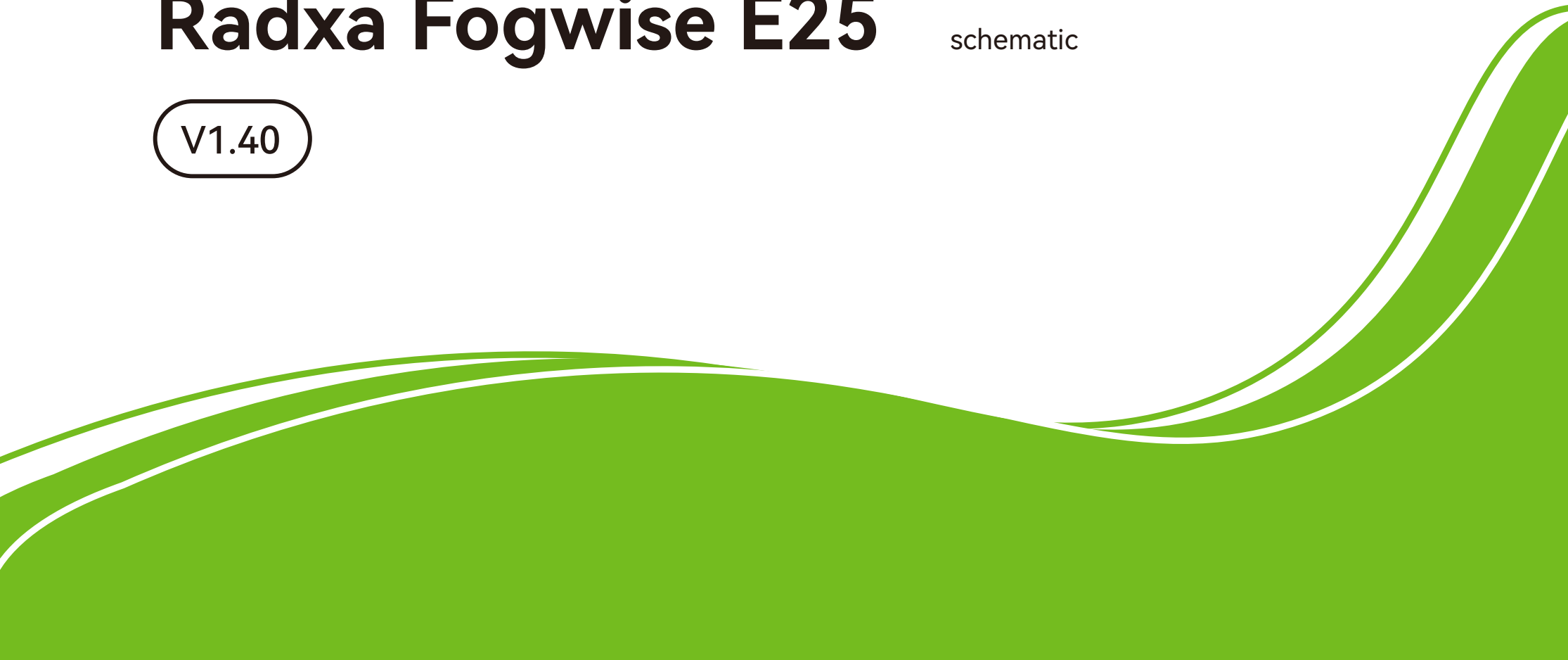

Radxa Fogwise E25

schematic

V1.40



Content

- 01.Cover
- 02.Content
- 03.Framwork
- 04.DC IN/TFCARD/KEY/RGB
- 05.USB2/USB3 Port
- 06._LAN2.5G_RTL8125B_PCIE2
- 07._LAN2.5G_RTL8125B_PCIE3
- 08.KEY-B-4G-sata/26p-connector
- 09.MinipCIE
- 10.PCIE-CLK
- 11.Connector_J2
- 12.Connector_J1
- 13.Connector_U1A
- 14.Connector_U1B



Size	Title: Radxa_E25	REV
A4	Page Name: 02.Content	1.4
Date: Tuesday, January 30, 2024	Sheet 2	of 14

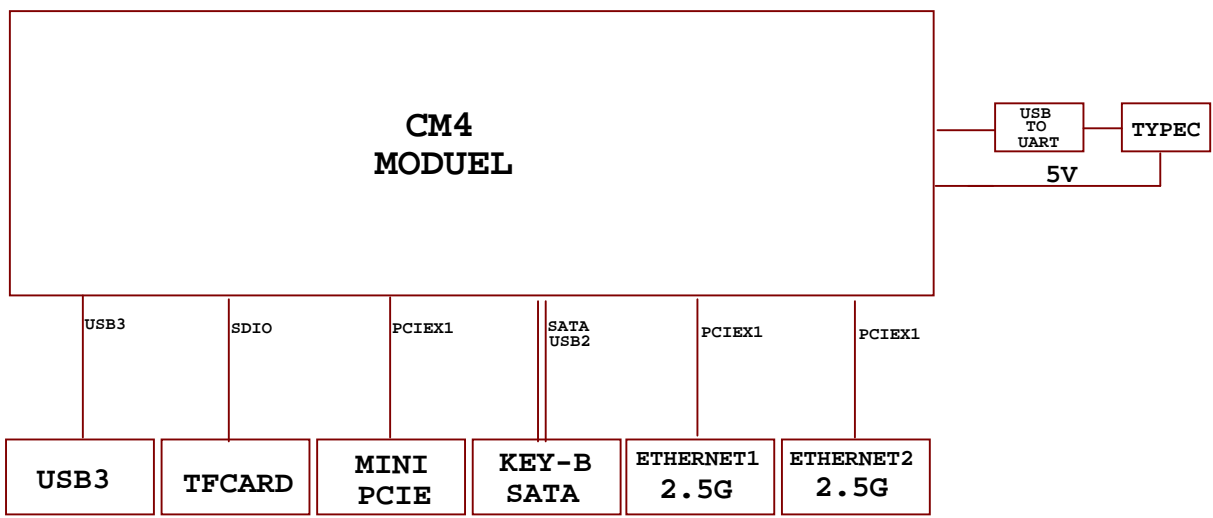

Size	Title: Radxa_E25	REV
A4	Page Name: 03.Framwork	1.4
Date: Tuesday, January 30, 2024	Sheet 3	of 14

5V/DEBUG

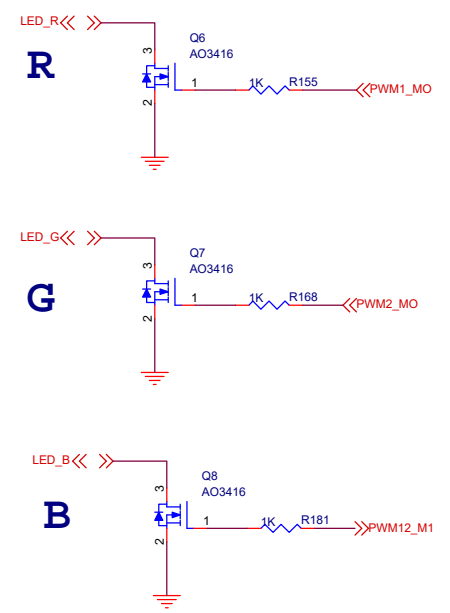
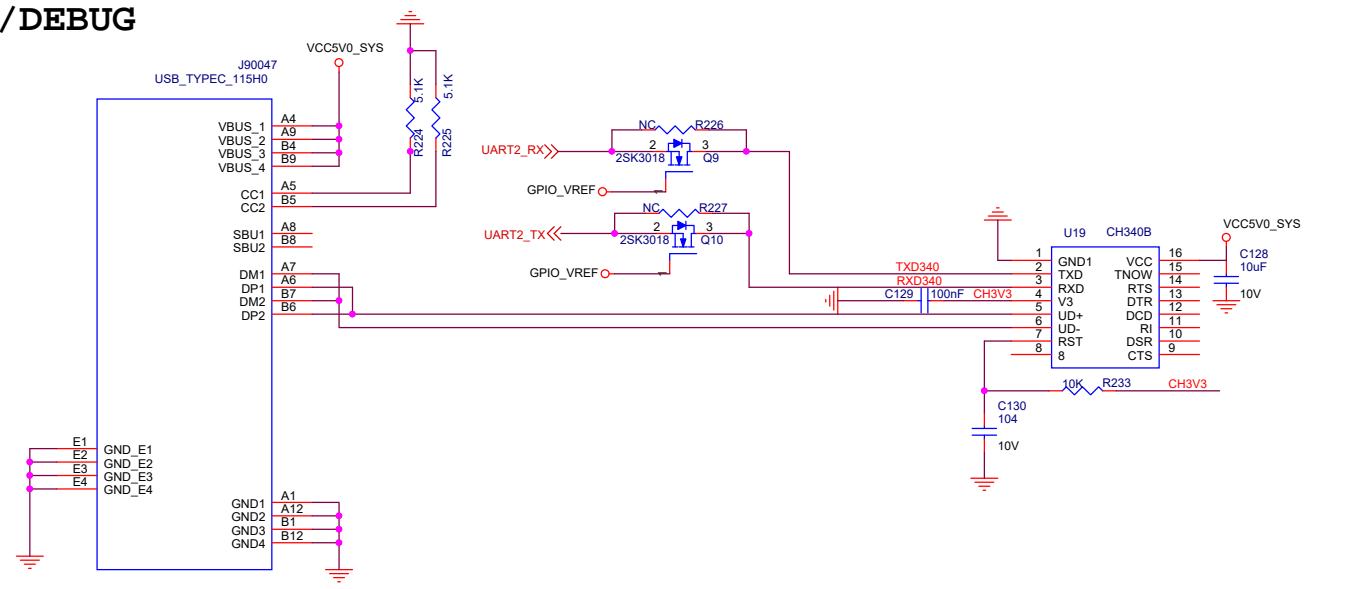

LED

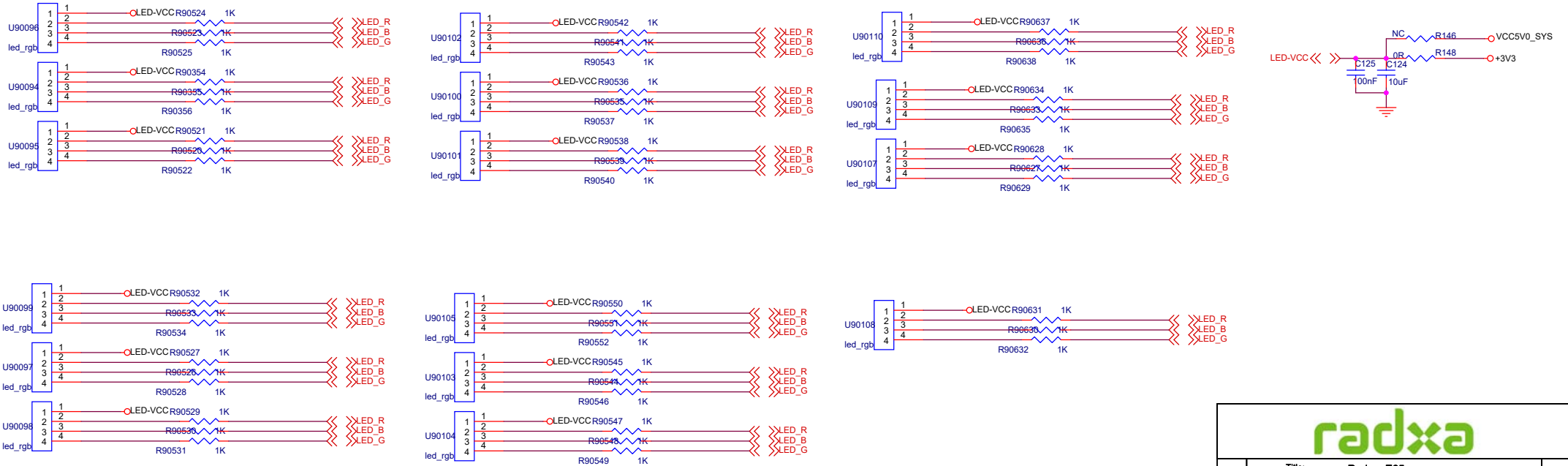

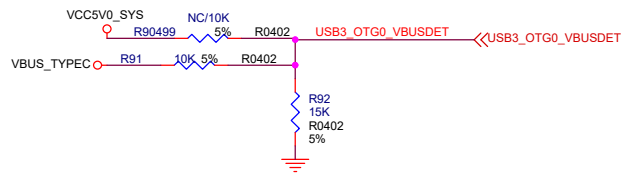
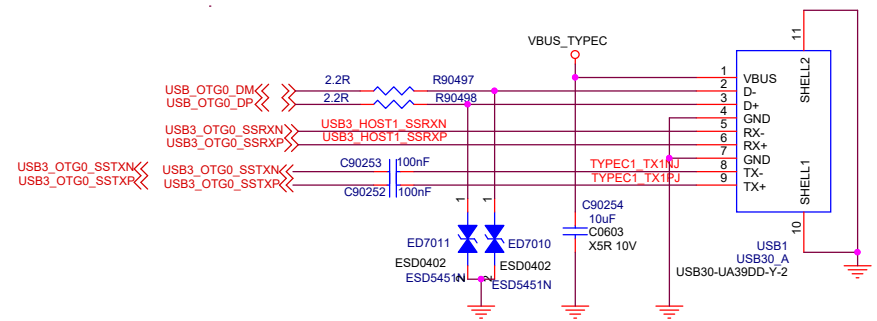
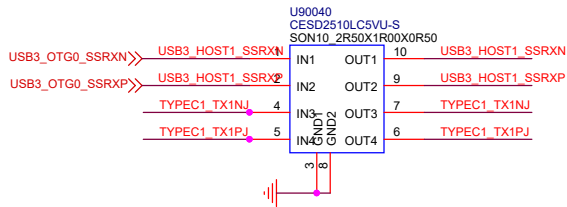

DEVICE/HOST

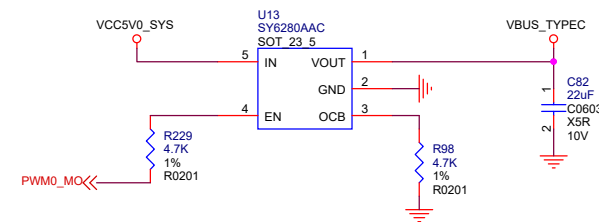
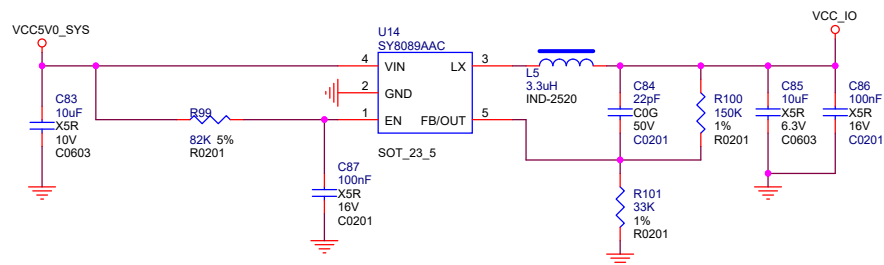
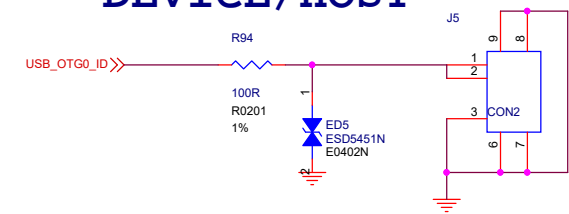

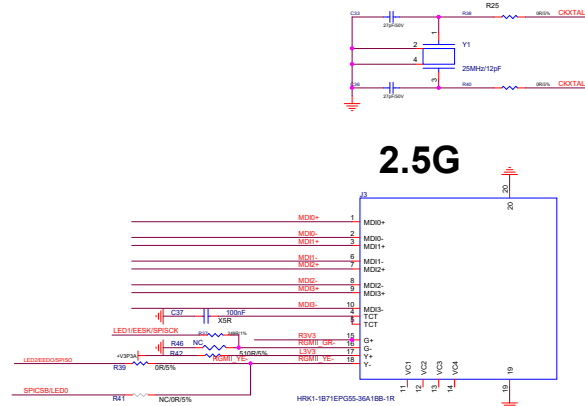
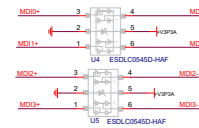
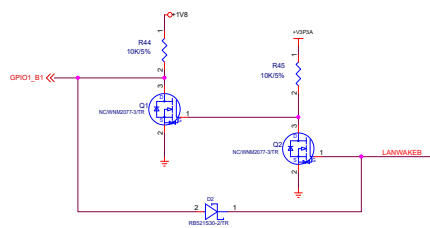
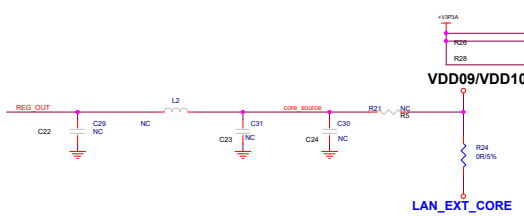
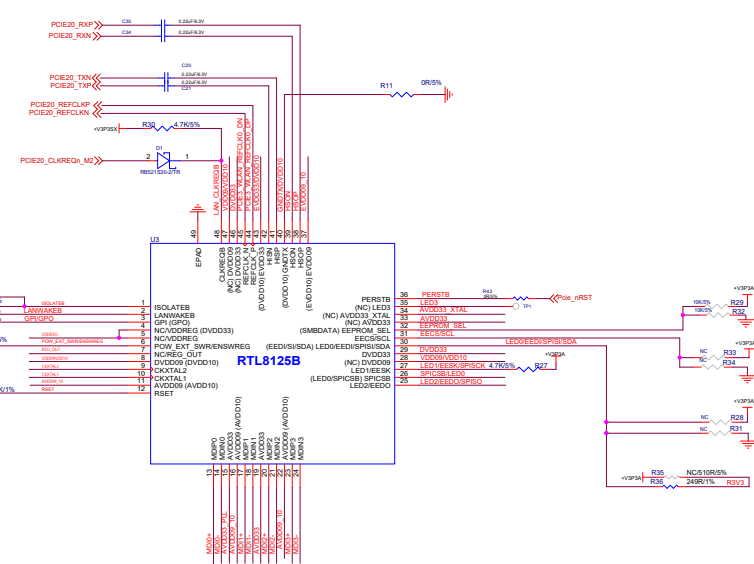
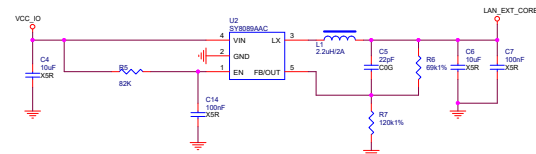
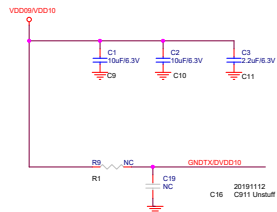
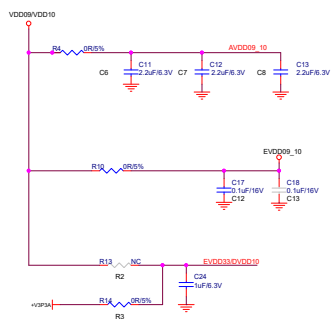
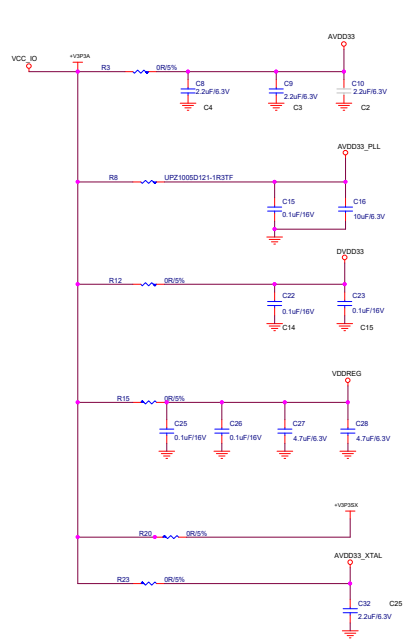

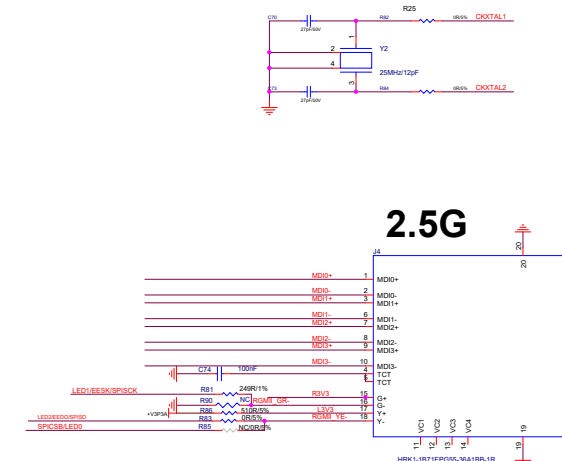
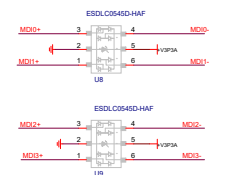
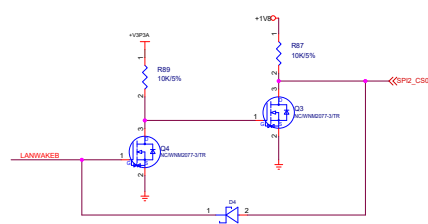
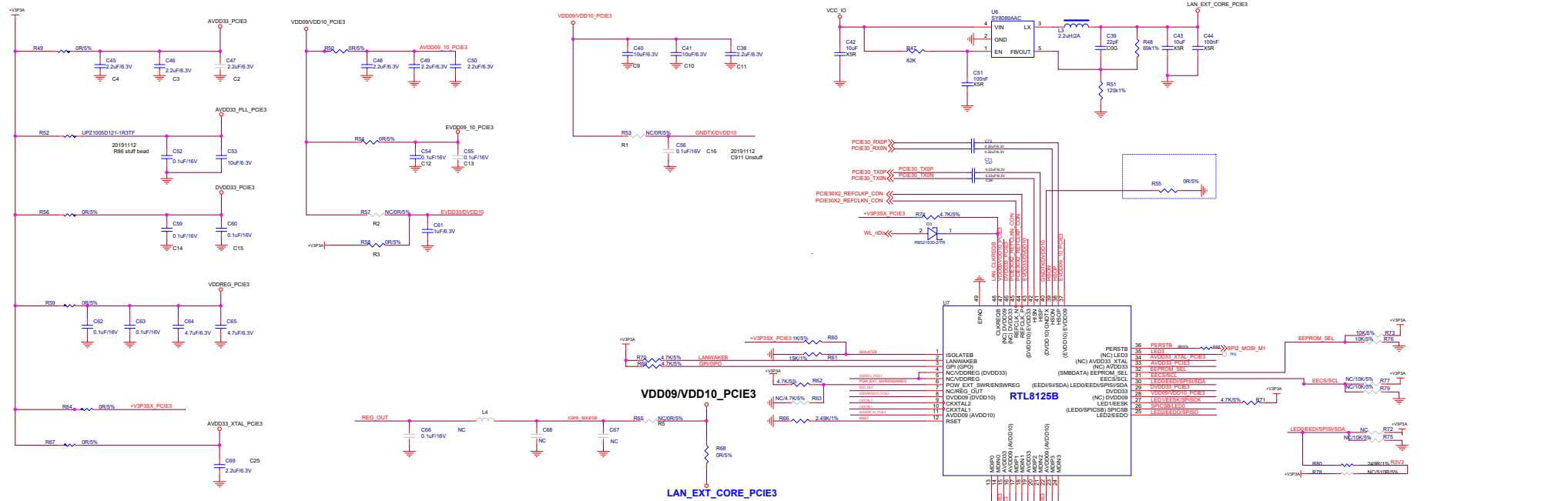

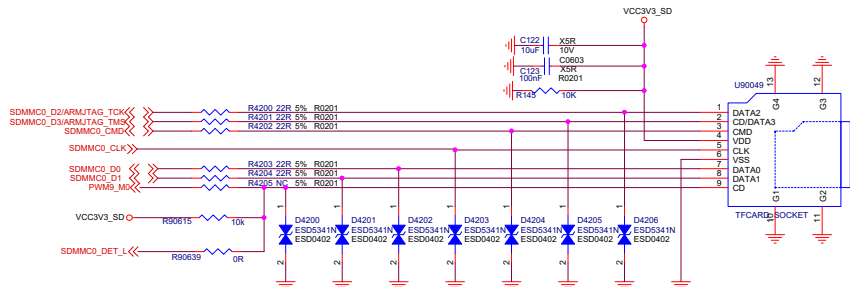
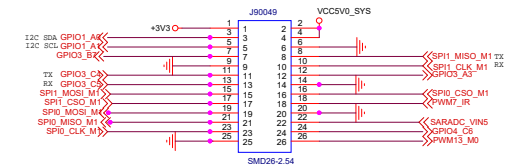
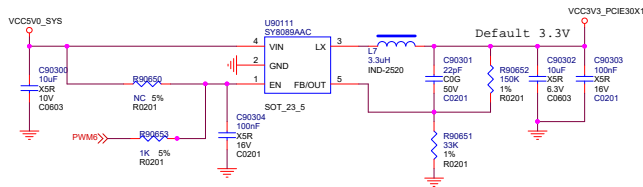
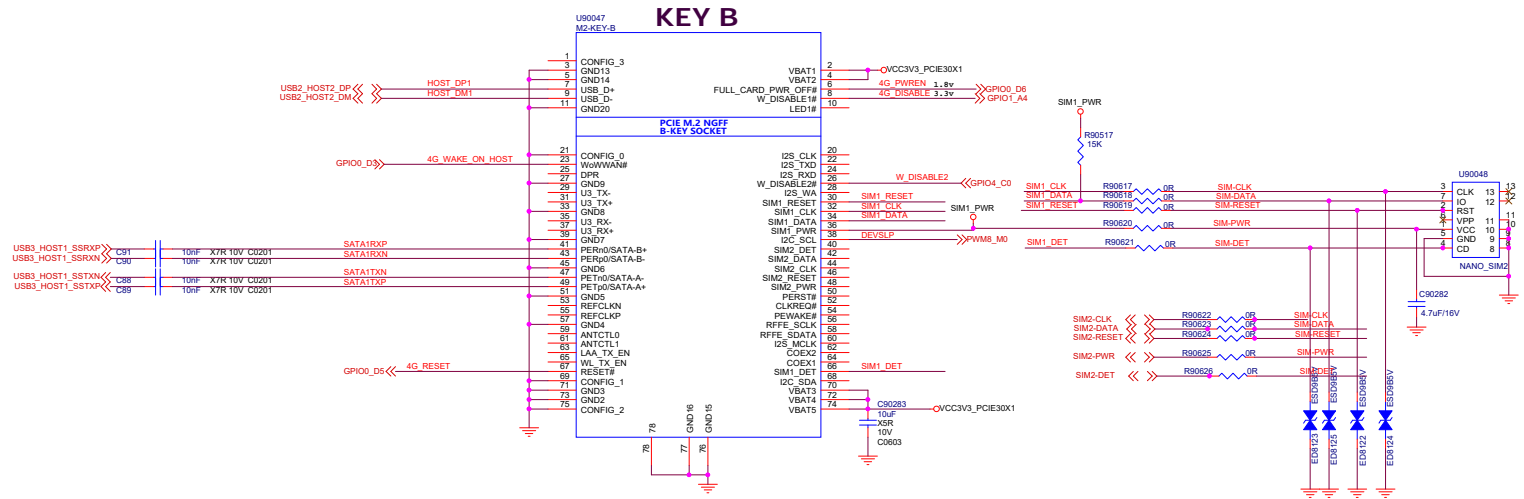

MiniPCIe2.0 Slot_Support 4G module

SMTS02046CTJ

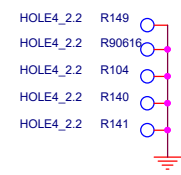
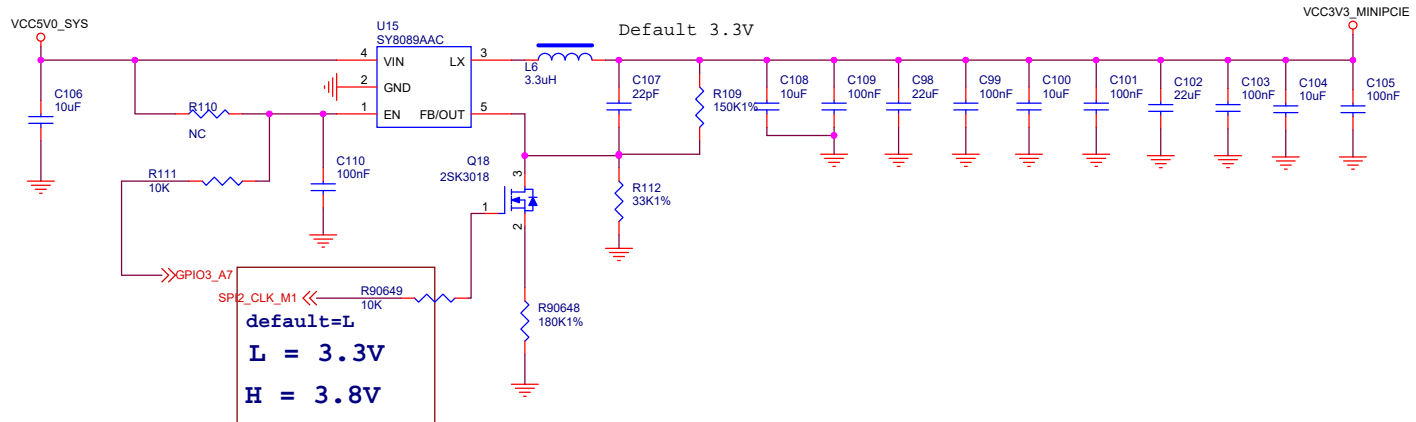
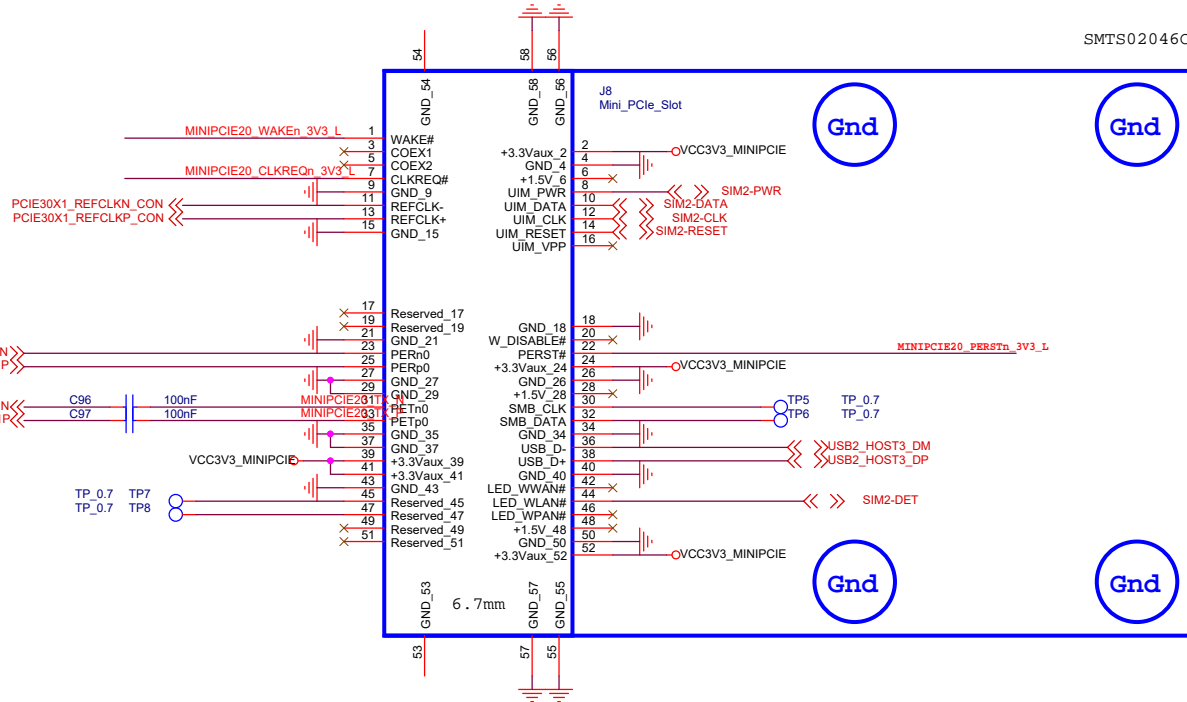
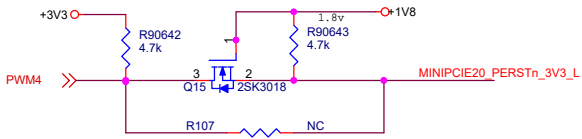
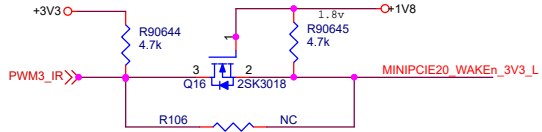
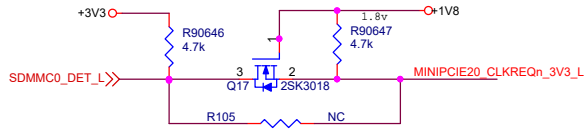

default=L
L = 3.3V
H = 3.8V

Size	Title: Radxa E25	REV
A3	Page Name: 09.MinipICle	1.4
Date: Tuesday, January 30, 2024	Sheet 9 of 14	

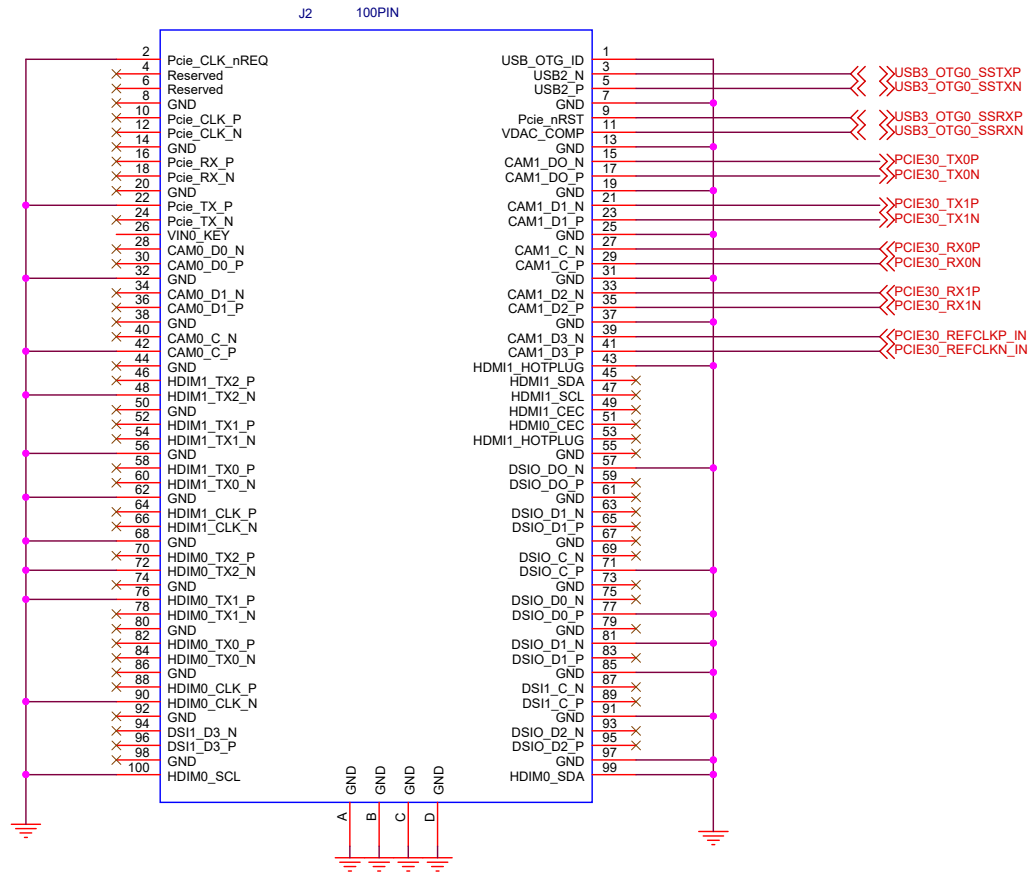

KEY

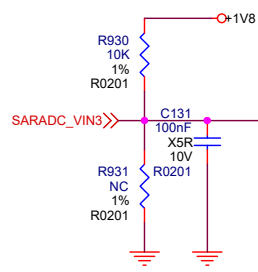
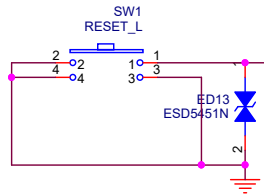

- GPIO0_D3 <<
- GPIO0_D4 <<
- GPIO0_D5 <<
- GPIO0_D6 <<
- GPIO1_A1 <<
- GPIO4_C0 <<
- GPIO1_A0 <<

- GPIO1_A4 <<
- GPIO1_B <<
- GPIO4_D2 <<
- PWM12_M_K <<

- I2C1_SCL_TP <<
- I2C1_SDA_TP <<

- VCC3V3_SD
- VCC_BATTERY
- SARADC_VIN3 >>
- SARADC_VIN5 >>

J1 100PIN

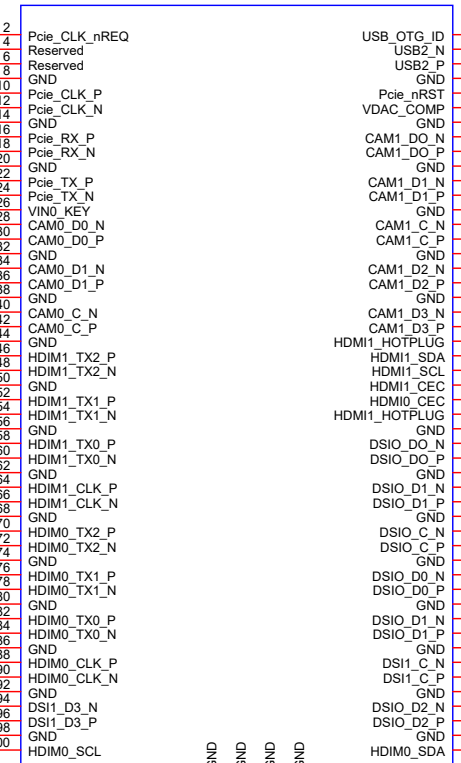



	Title: Radxa_E25	REV
B	Page Name: 12.Connector_J1	1.4
Date:	Tuesday, January 30, 2024	Sheet 12 of 14

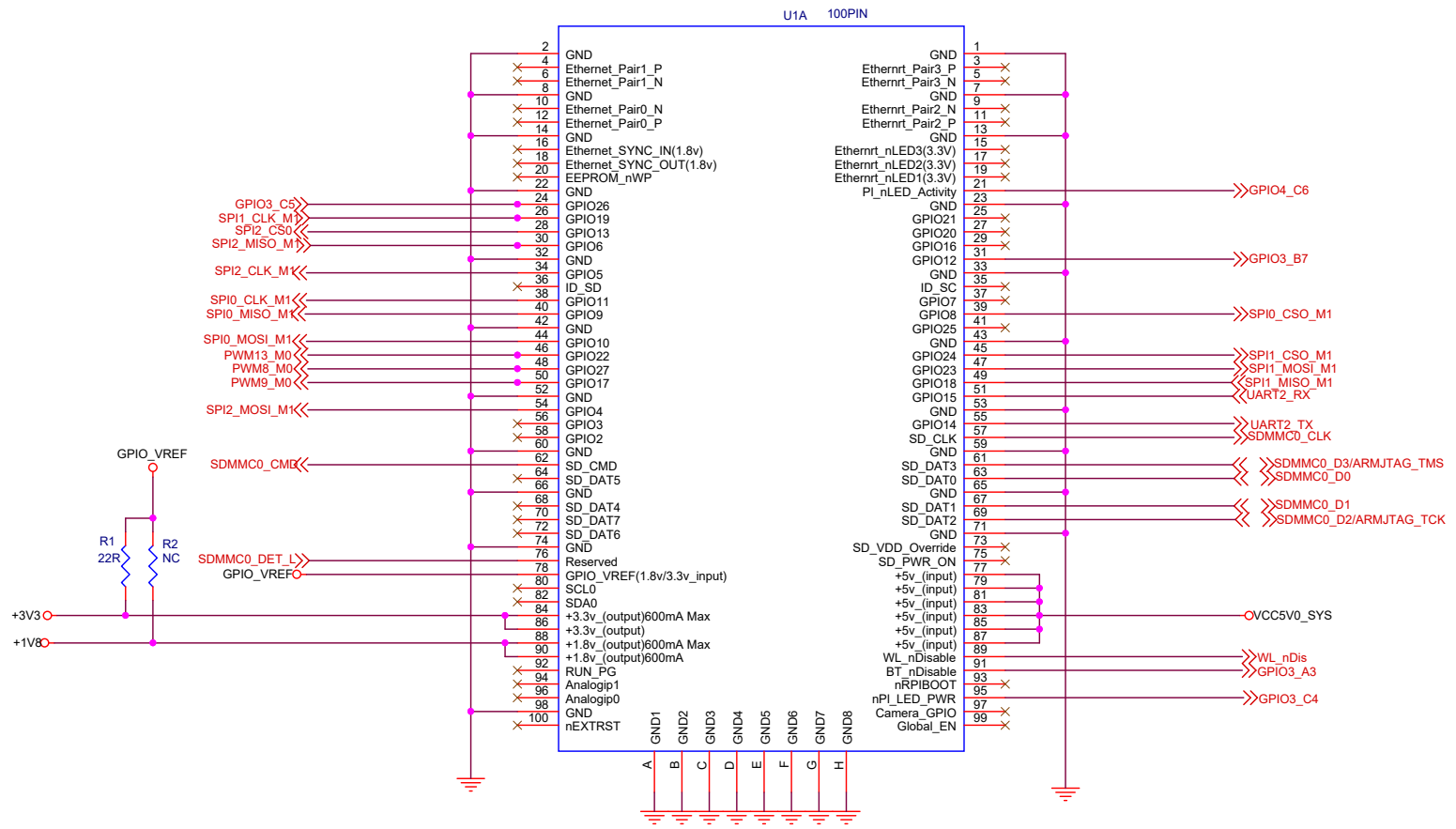

Size	Title: Radxa_E25	REV
B	Page Name: 13.Connector_U1A	1.4
Date:	Tuesday, January 30, 2024	Sheet 13 of 14

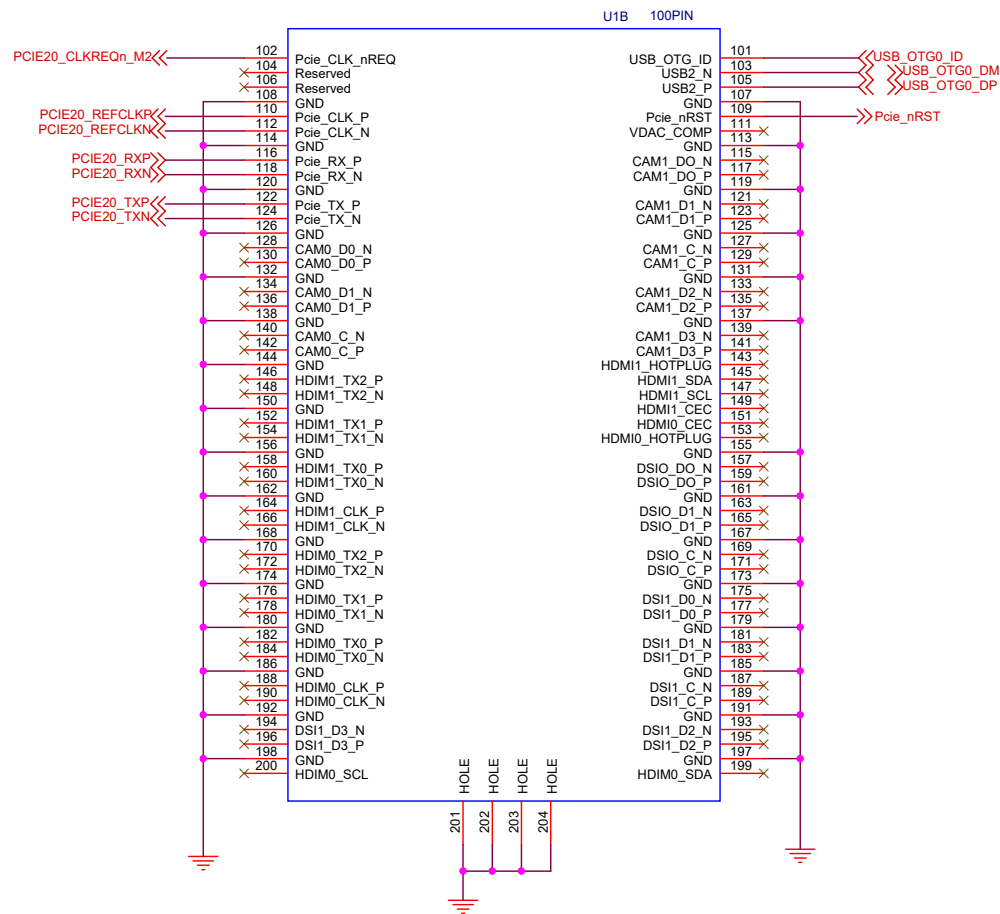

Size	Title: Radxa_E25	REV
B	Page Name: 14.Connector_U1B	1.4
Date:	Tuesday, January 30, 2024	Sheet 14 of 14