



Radxa Fogwise E25 schematic

V1.41

Content

- 01.Cover
- 02.Content
- 03.Framwork
- 04.DC IN/TFCARD/KEY/RGB
- 05.USB2/USB3 Port
- 06 LAN2.5G RTL8125B_PCIE2
- 07 LAN2.5G RTL8125B_PCIE3
- 08 KEY-B-4G-sata/26p-connector
- 09.MinipCIE
- 10.PCIE-CLK
- 11.Connector_J2
- 12.Connector_J1
- 13.Connector_U1A
- 14.Connector_U1B



Size	Title: Radxa_E25	REV
A4	Page Name: 02.Content	1.41
Date: Friday, February 02, 2024	Sheet 2	of 14

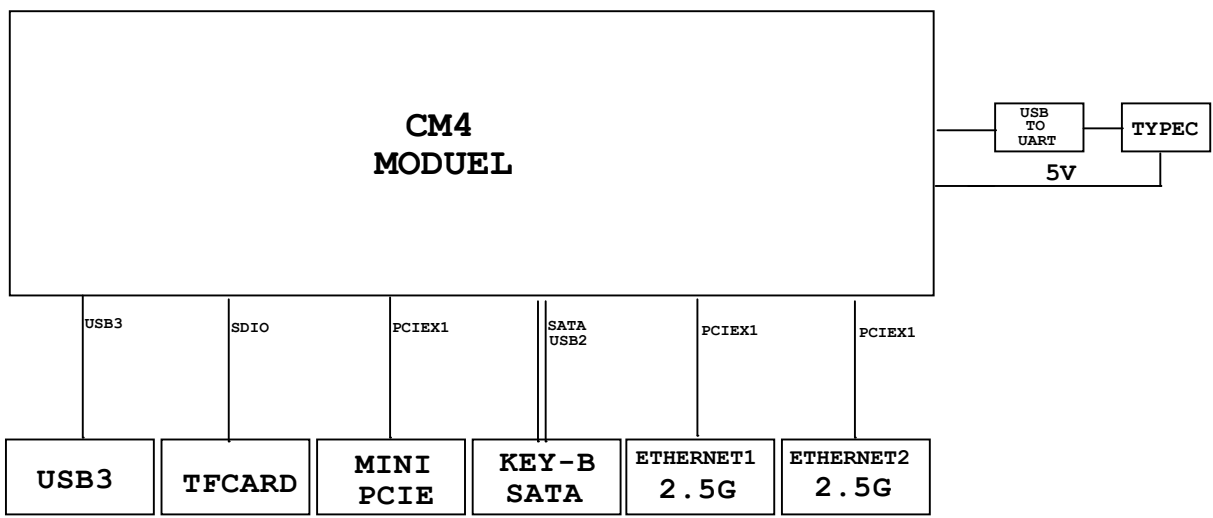

Size	Title: Radxa_E25	REV
A4	Page Name: 03.Framwork	1.41
Date: Monday, January 29, 2024	Sheet 3	of 14

5V/DEBUG

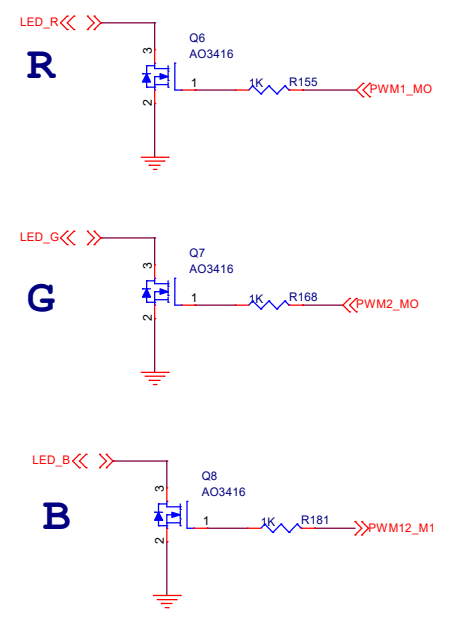
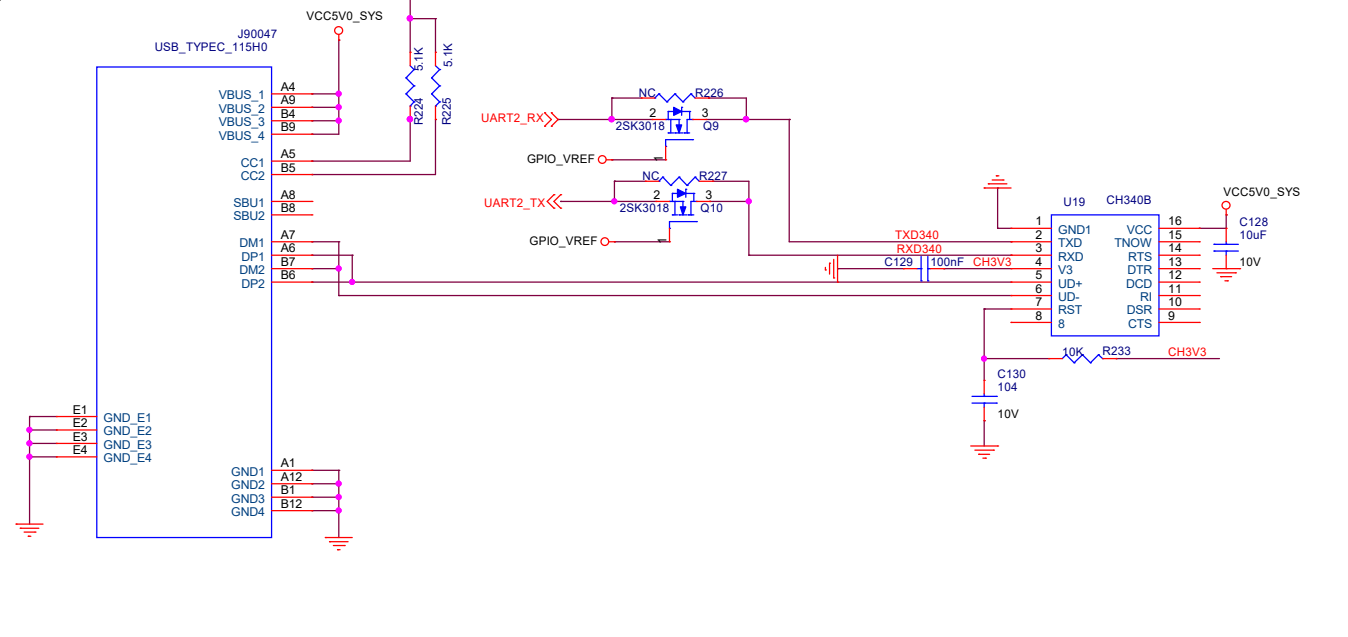

LED

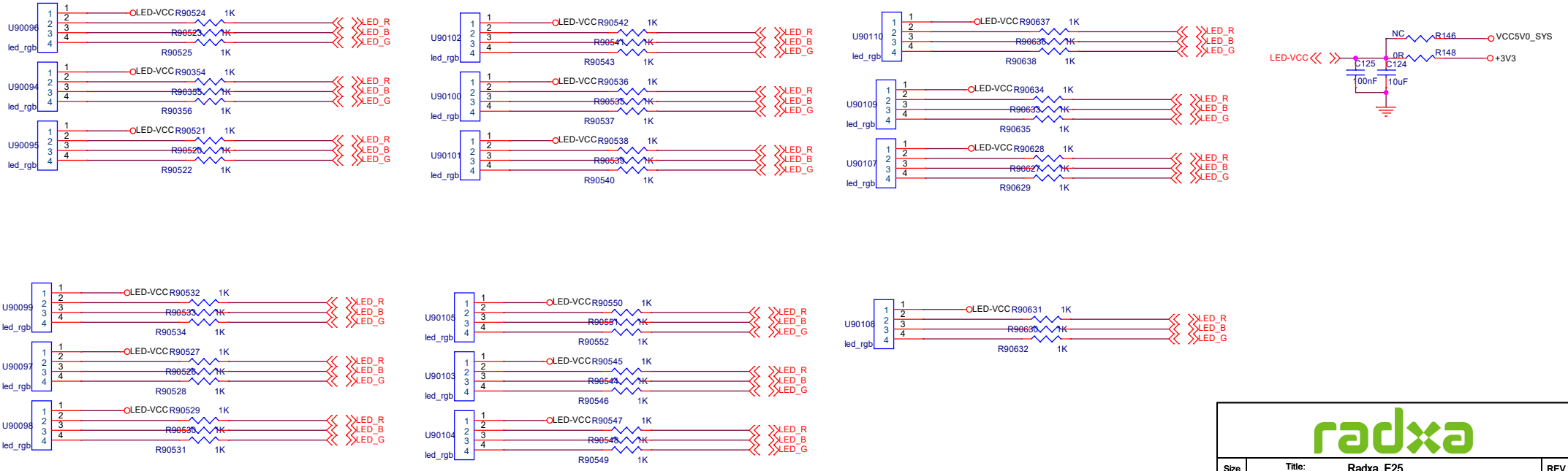

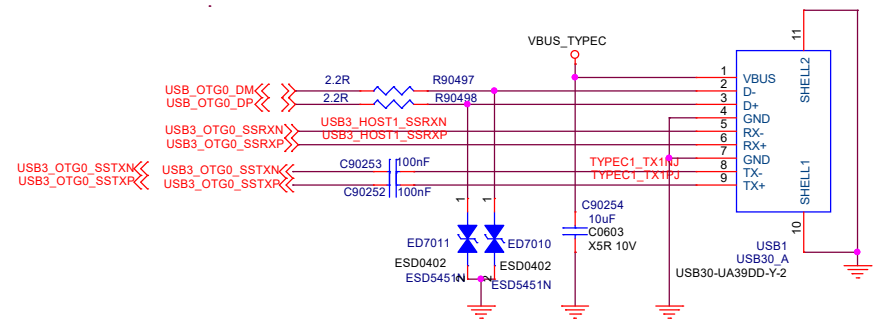
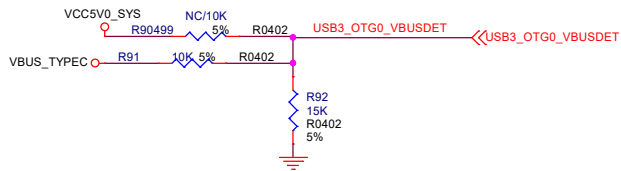
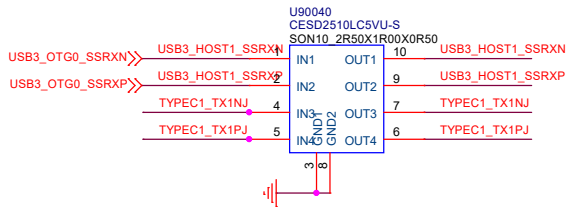

DEVICE/HOST

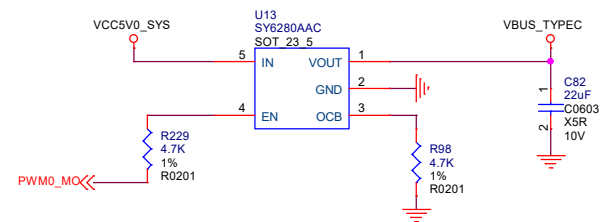
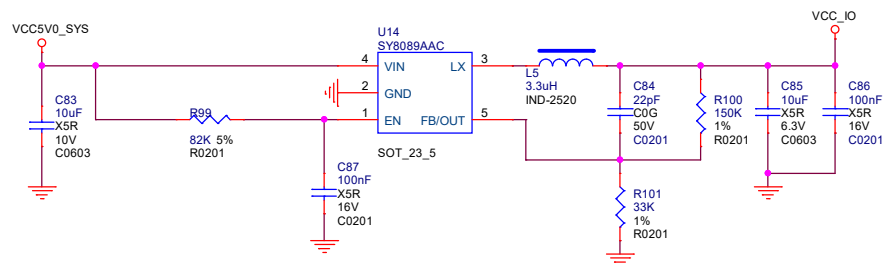
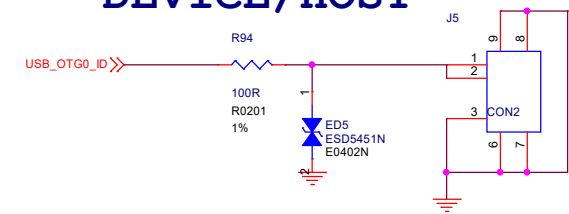

radxa

Size	Title: Radxa_E25	REV
A3	Page Name: 05.USB2/USB3 Port	1.41
Date: Friday, February 02, 2024	Sheet 5 of 14	

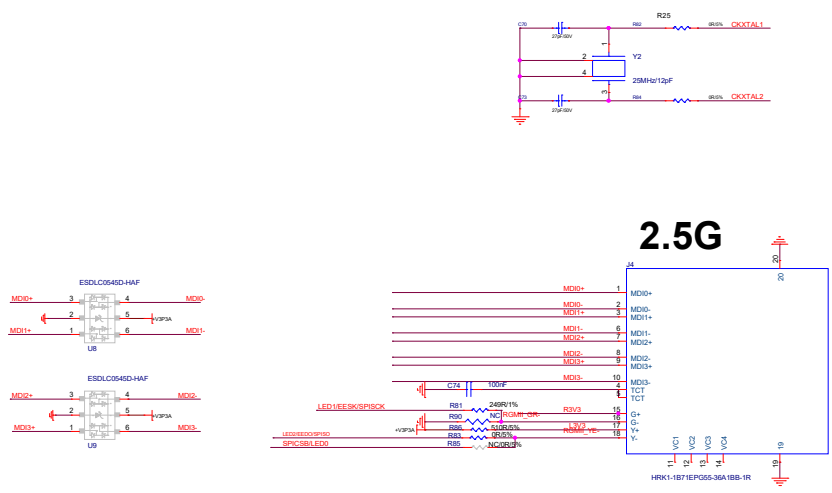
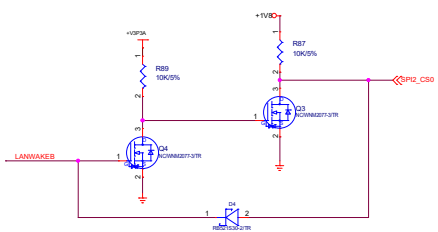
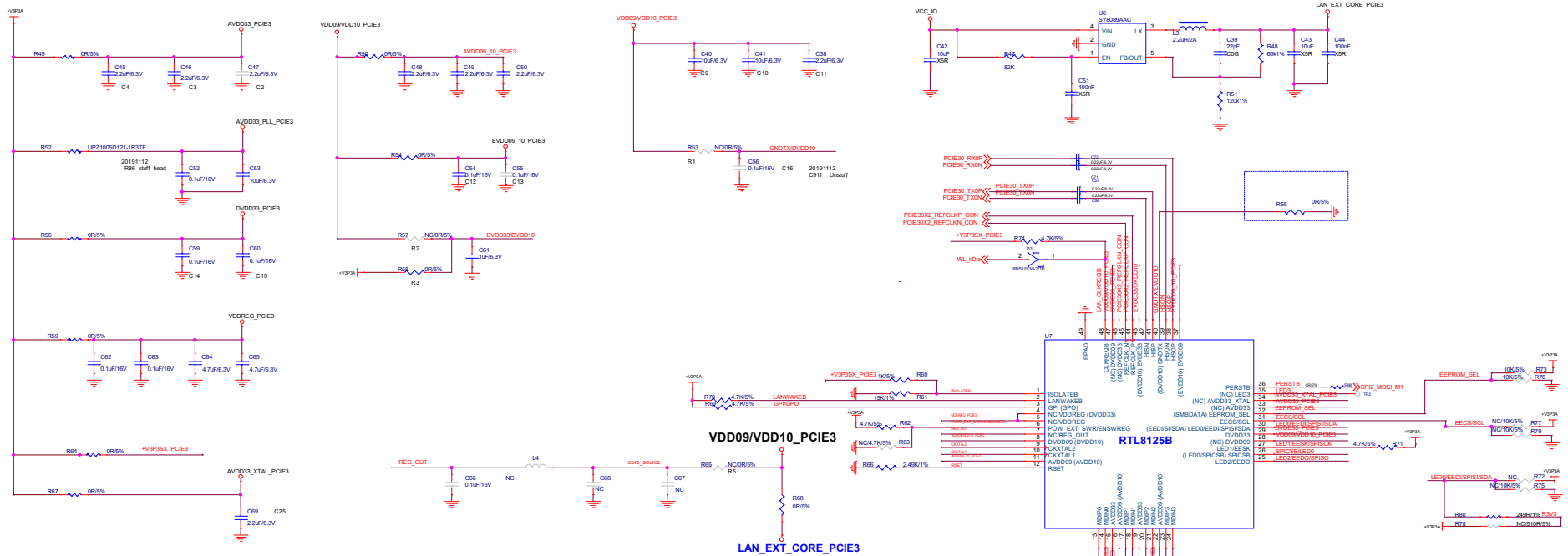

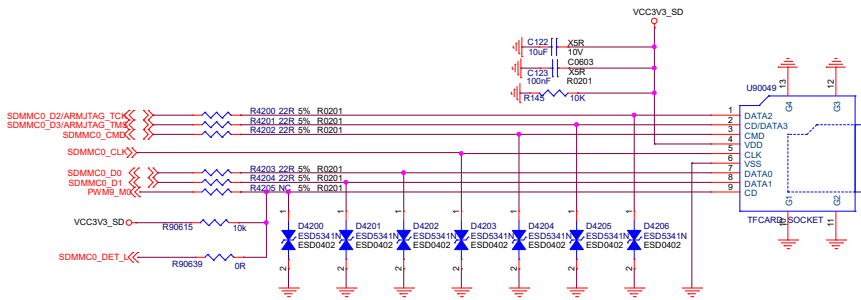
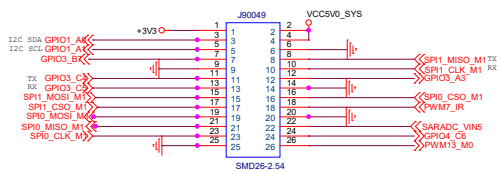
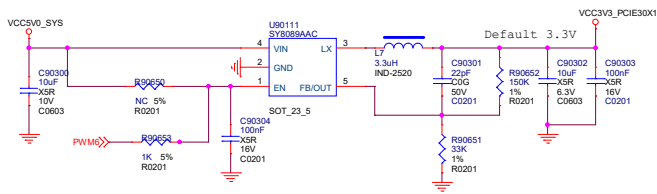
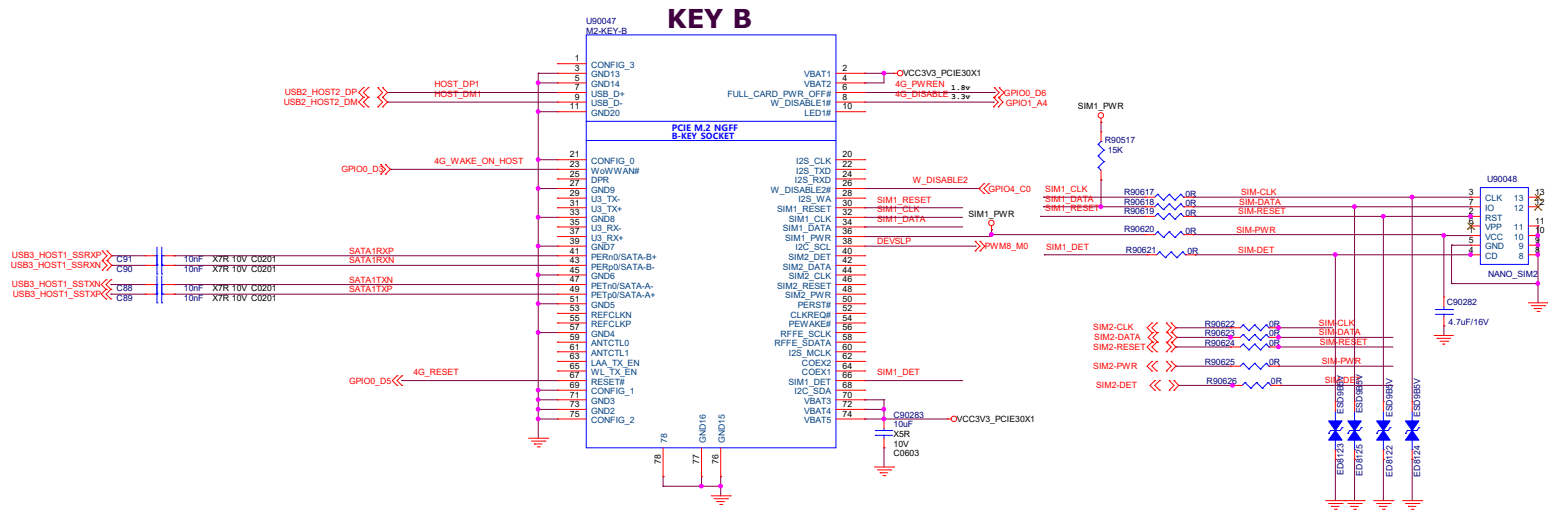

MiniPCIE2.0 Slot_Support 4G module

SMTS02046CTJ

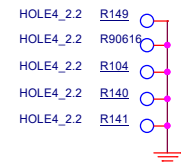
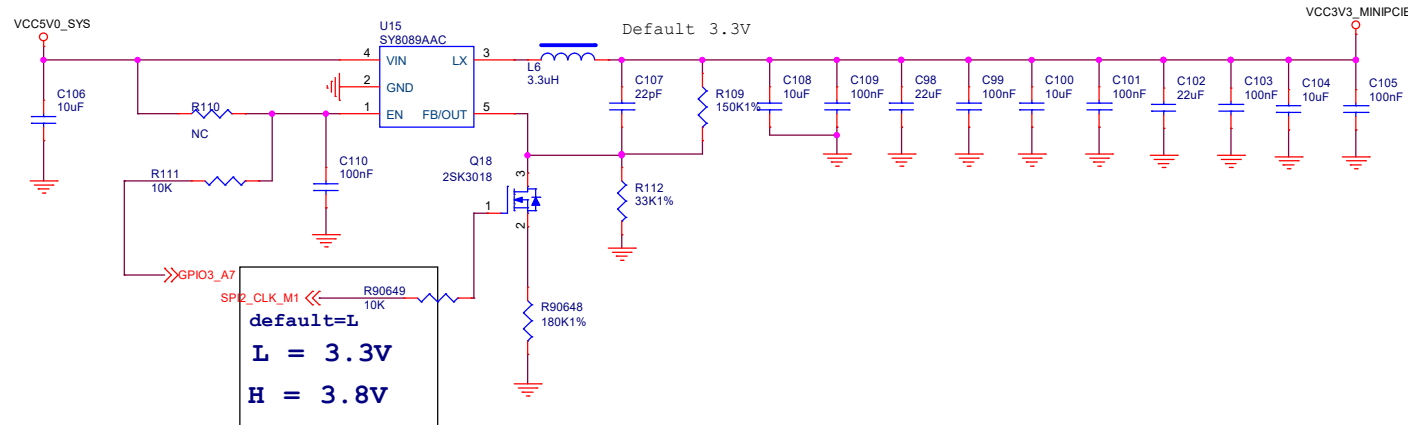
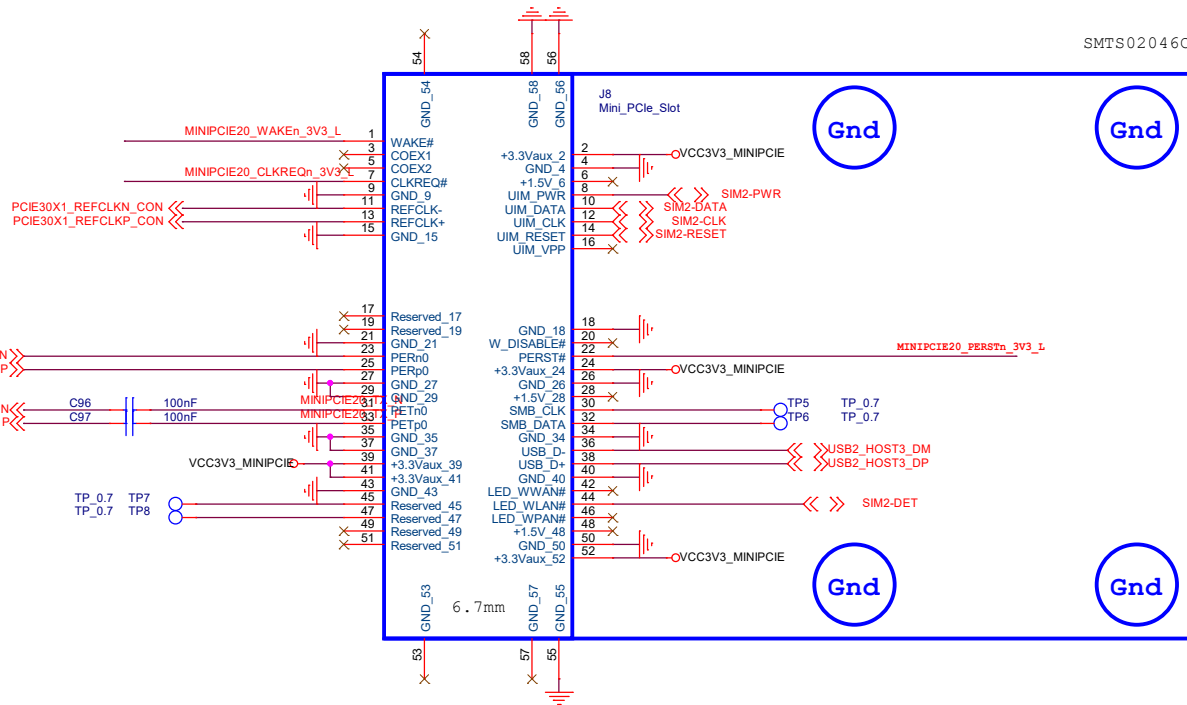
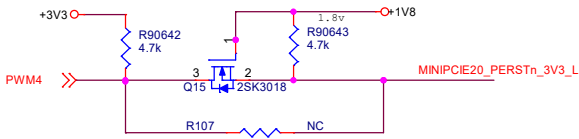
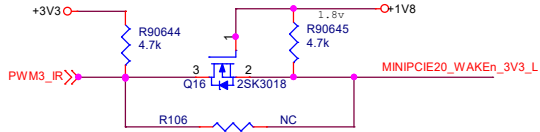
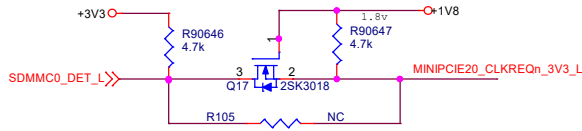

default=L
L = 3.3V
H = 3.8V

Size	Title: Radxa E25	REV
A3	Page Name: 09.MinipCie	1.41
Date: Friday, February 02, 2024	Sheet 9 of 14	

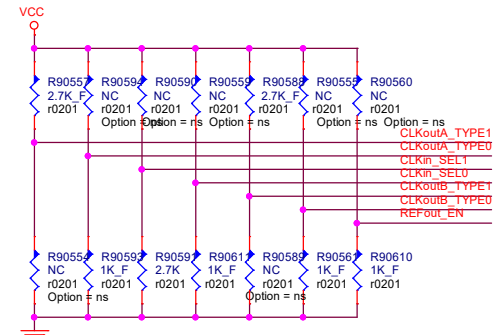
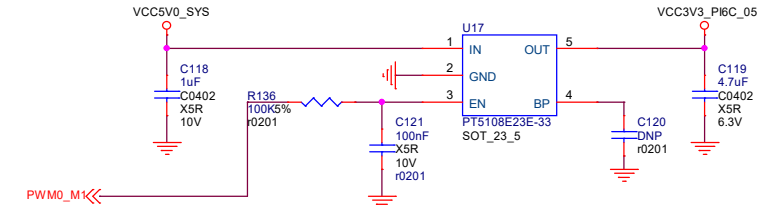
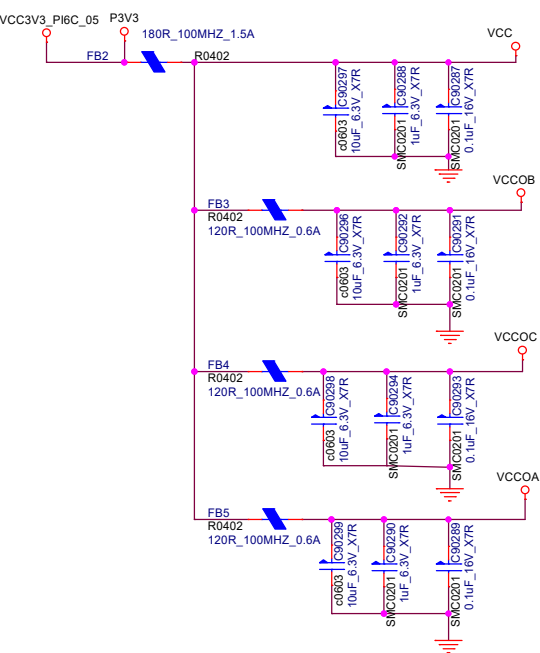
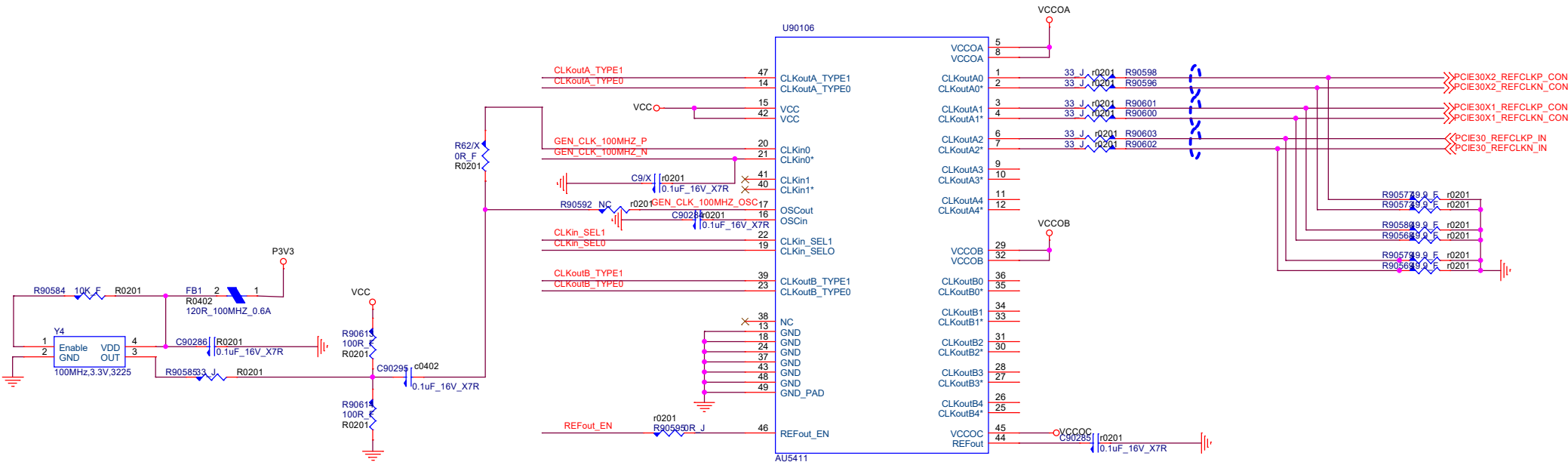

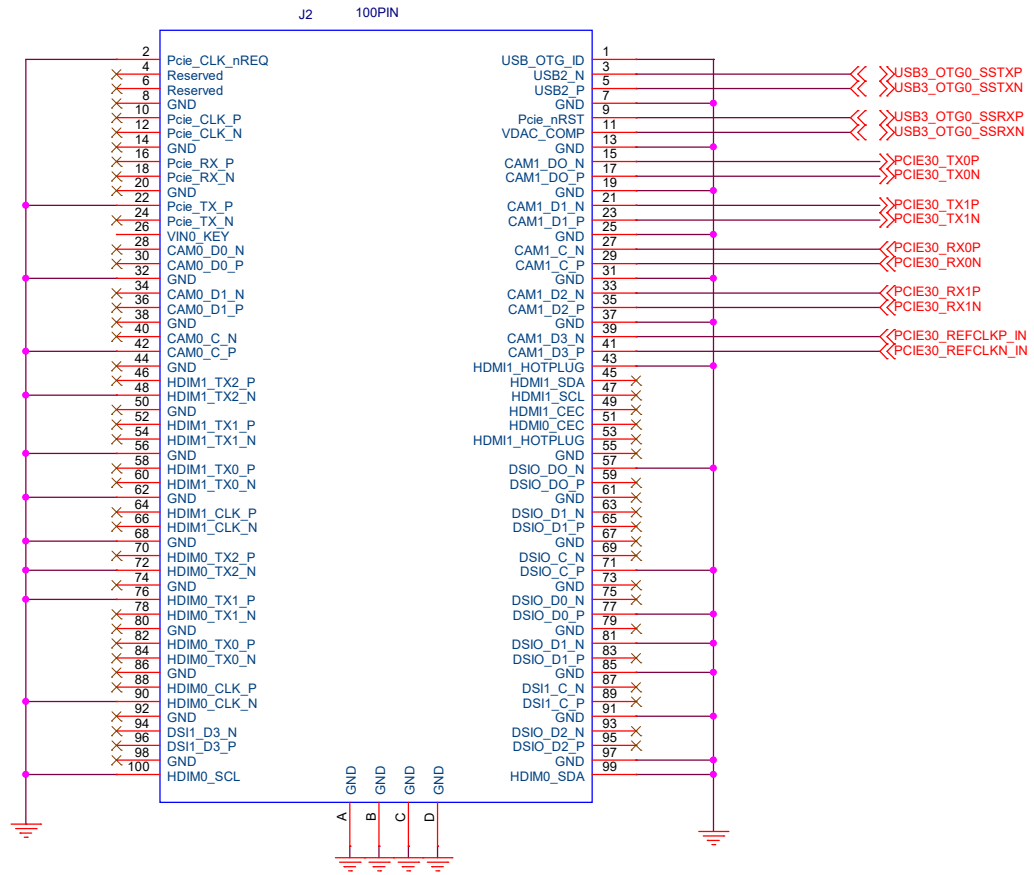



Size	Title: Radxa_E25	REV
B	Page Name: 11.Connector_J2	1.41
Date: Friday, February 02, 2024 Sheet 11 of 14		

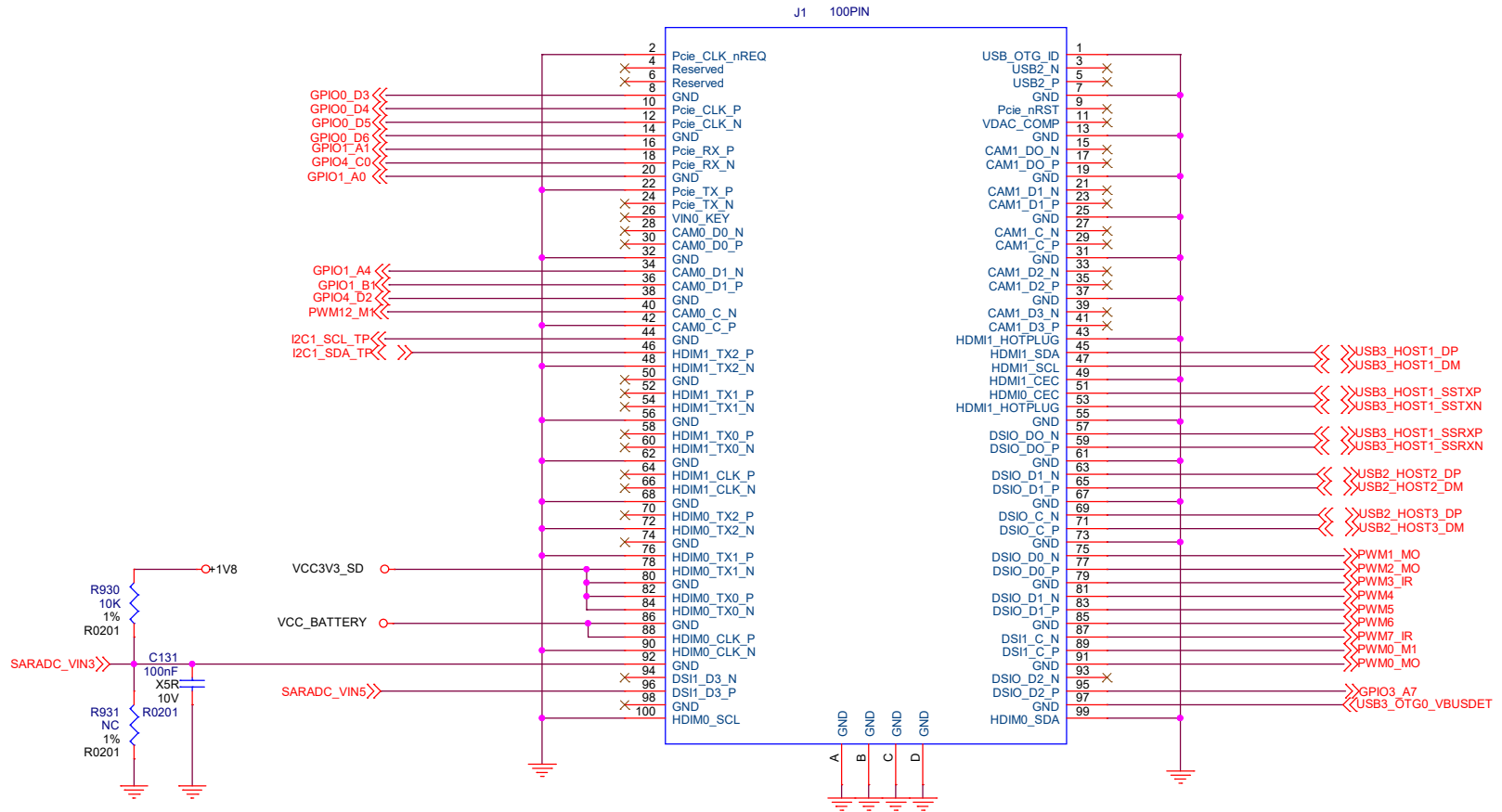

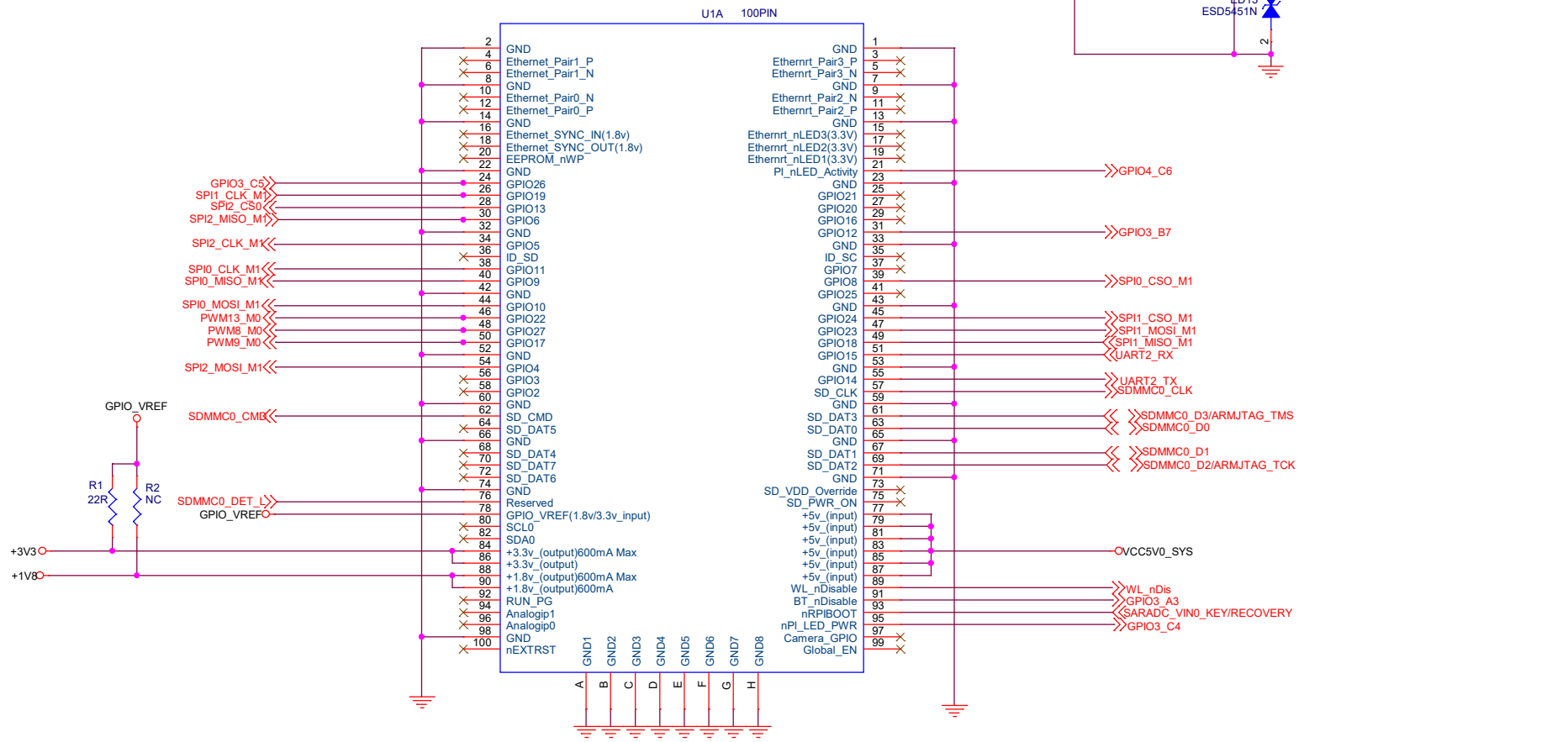

radxa

Size	Title: Radxa_E25	REV
B	Page Name: 12.Connector_J1	1.41
Date: Friday, February 02, 2024 Sheet 12 of 14		

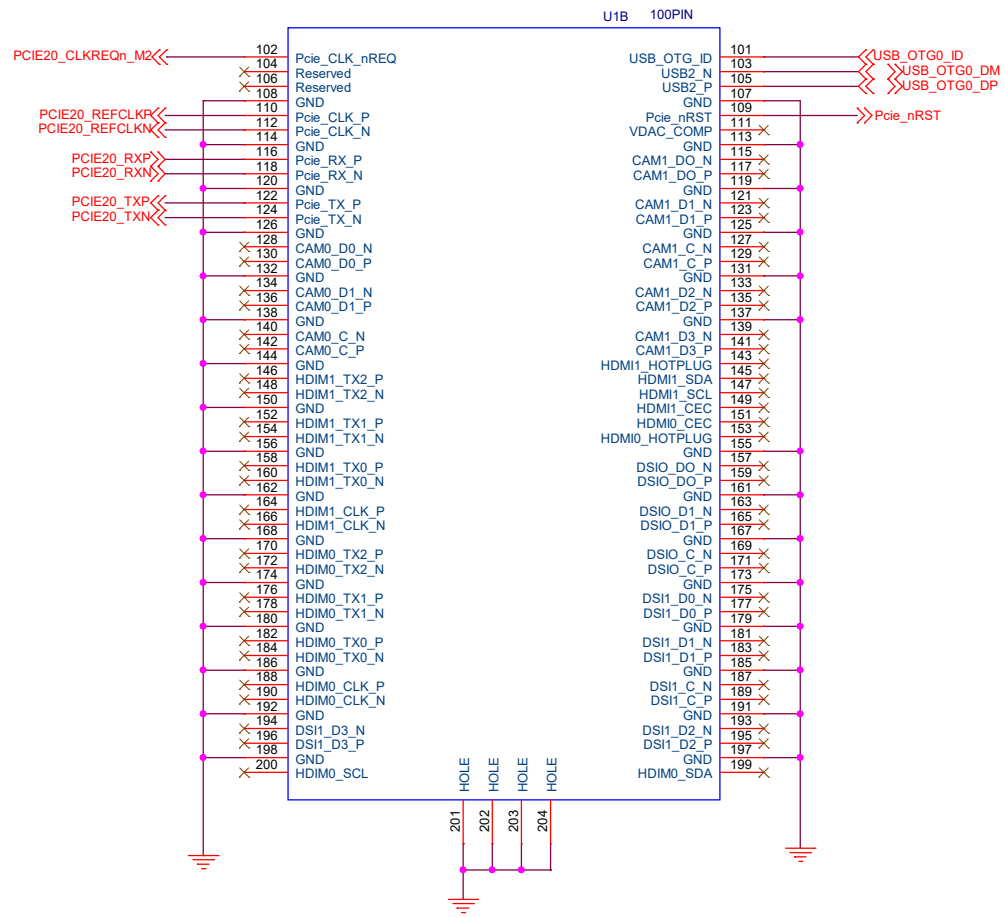

Size	Title: Radxa_E25	REV
B	Page Name: 13.Connector_U1A	1.41
Date: Friday, February 02, 2024	Sheet 13 of 14	



		
Size	Title: Radxa_E25	REV
B	Page Name: 14.Connector_U1B	1.41
Date: Friday, February 02, 2024	Sheet 14	of 14