



Radxa Dragon Q8B

schematic

V1.3

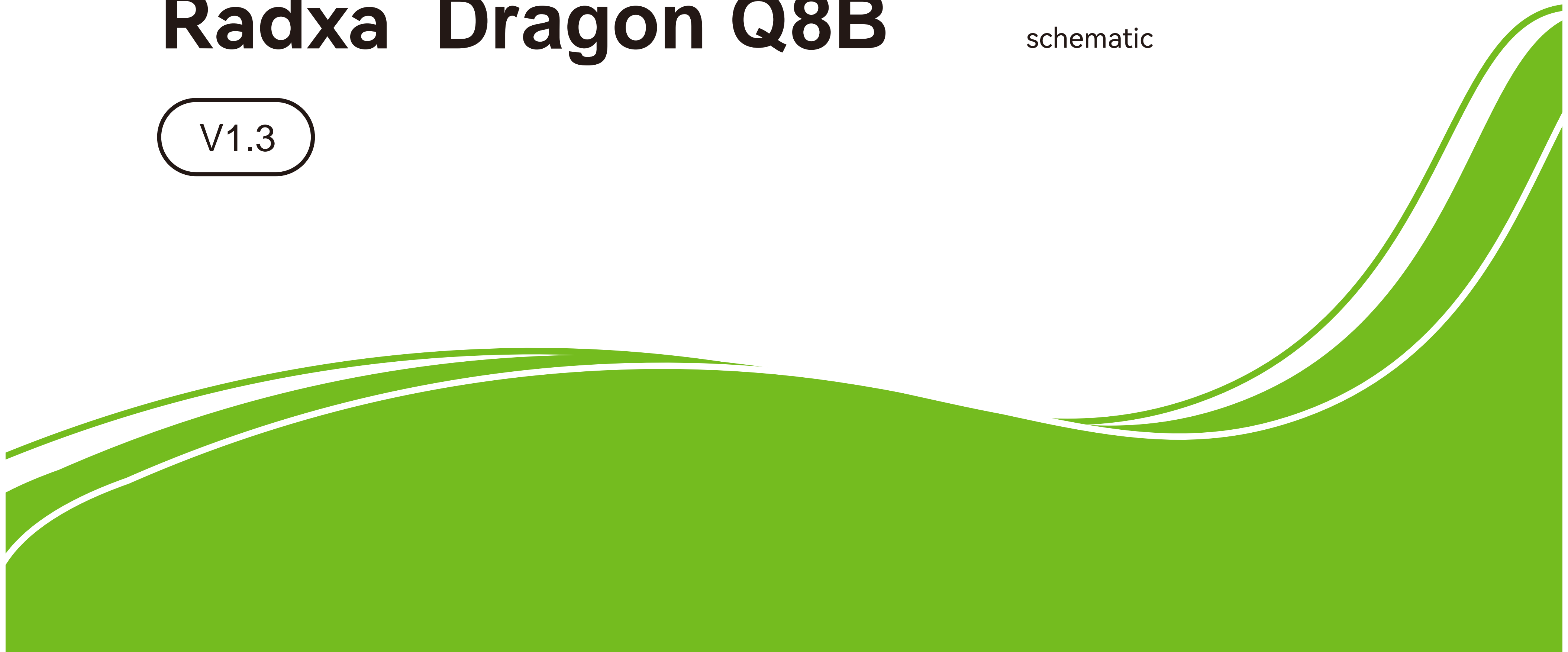
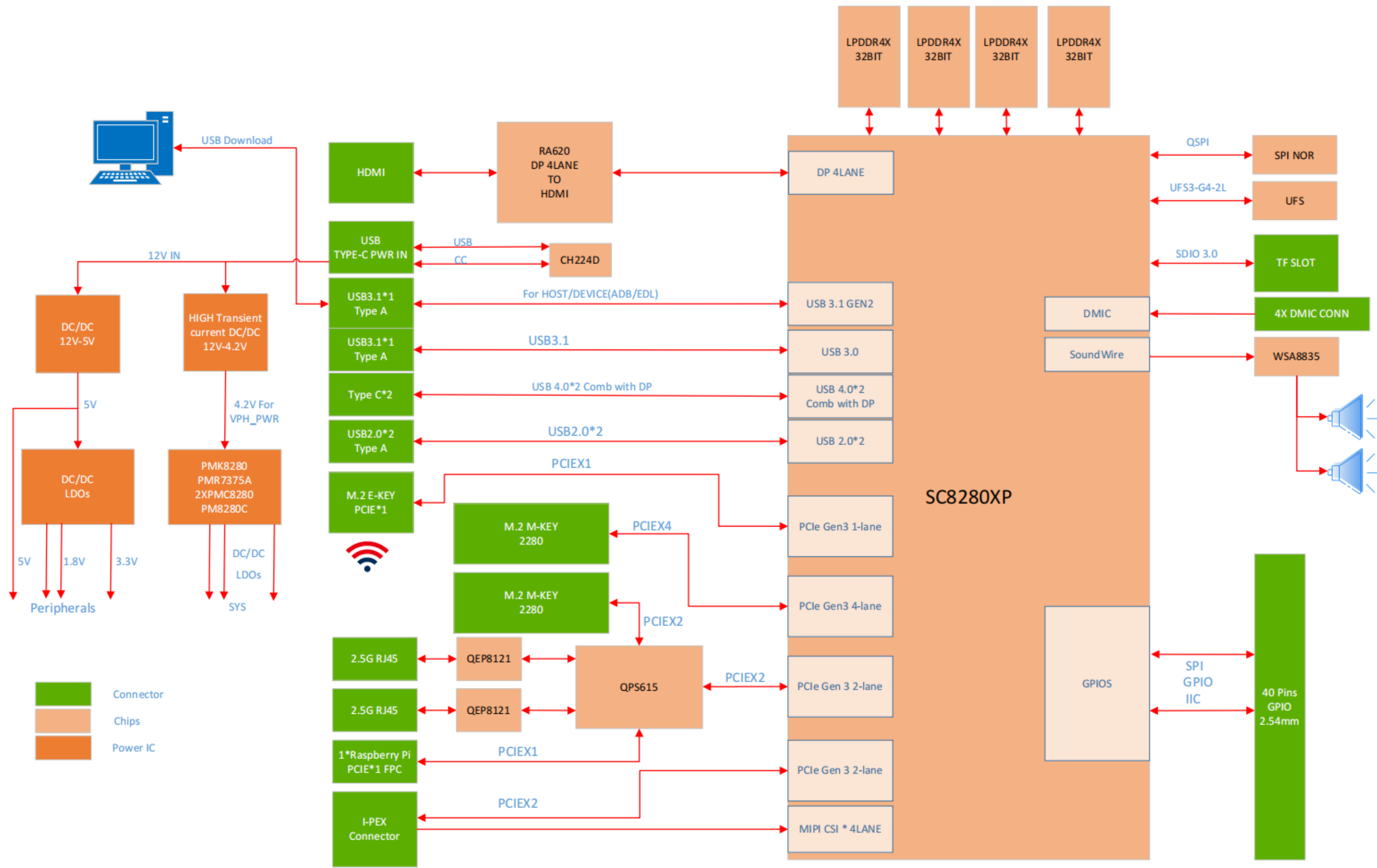

Table of Content

Page 1	Index and Notes
Page 2	Block Diagram
Page 3	Power Tree(delete)
Page 4	SC8280XP_GPIO1
Page 5	SC8280XP_GPIO2
Page 6	SC8280XP_GPIO3
Page 7	SC8280XP_EBI_0_3
Page 8	SC8280XP_EBI_4_7
Page 9	SC8280XP_SERDES1
Page 10	SC8280XP_SERDES2
Page 11	SC8280XP_SERDES3
Page 12	SC8280XP_PWR1
Page 13	SC8280XP_PWR2
Page 14	SC8280XP_PWR3
Page 15	SC8280XP_GND
Page 16	LPDDR4X_EBI0_1
Page 17	LPDDR4X_EBI2_3
Page 18	LPDDR4X_EBI4_5
Page 19	LPDDR4X_EBI6_7
Page 20	SC8280XP_DECAP
Page 21	PMC8280_1_BUCK_S1_S6
Page 22	PMC8280_1_BUCK_S7_S12
Page 23	PMC8280_1_HK/IO/GND/LDO
Page 24	PMC8280_2_BUCK_S1_S6
Page 25	PMC8280_2_BUCK_S7_S12
Page 26	PMC8280_2_HK/IO/GND/LDO
Page 27	PMC8280C_BUCK_S1_S5
Page 28	PMC8280C_BUCK_S6_S10
Page 29	PMC8280C_BOB/FLASH/HK/LDO
Page 30	PMR735A
Page 31	PMK8280
Page 32	SMB2351_1_2
Page 33	PMC1010H_1
Page 34	PMC1010H_2
Page 35	BAT_SEN
Page 36	TYPEC
Page 37	40PIN
Page 38	UFS&SPI_NOR
Page 39	M.2 EKEY
Page 40	M.2_M KEY
Page 41	M.2_M-KEY_2
Page 42	USB
Page 43	DP TO HDMI
Page 44	TYPEC-IN
Page 45	PCIE BRIDGE
Page 46	PCIE BRIDGE_2
Page 47	ETH_2.5G_0
Page 48	ETH_2.5G_1
Page 49	IPEX
Page 50	AUDIO

Block Diagram



SC8280XP_GPIO1

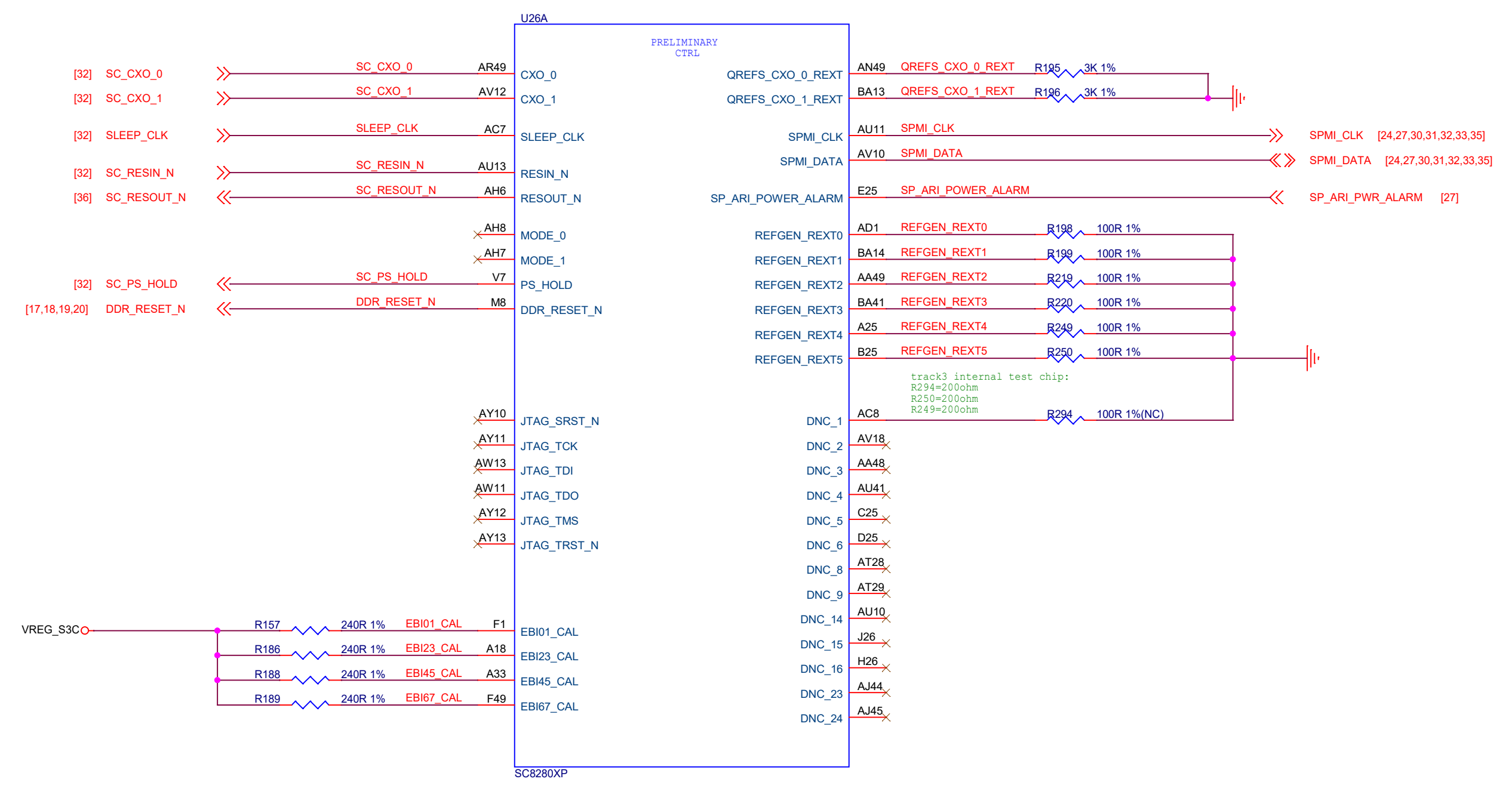

Size	Title: Radxa Dragon Q8	REV
C	Page Name: <Doc>	V1.3
Date:	Monday, June 22, 2026	Sheet 4 of 50

SC8280XP_GPIO2



SC8280XP_GPIO3

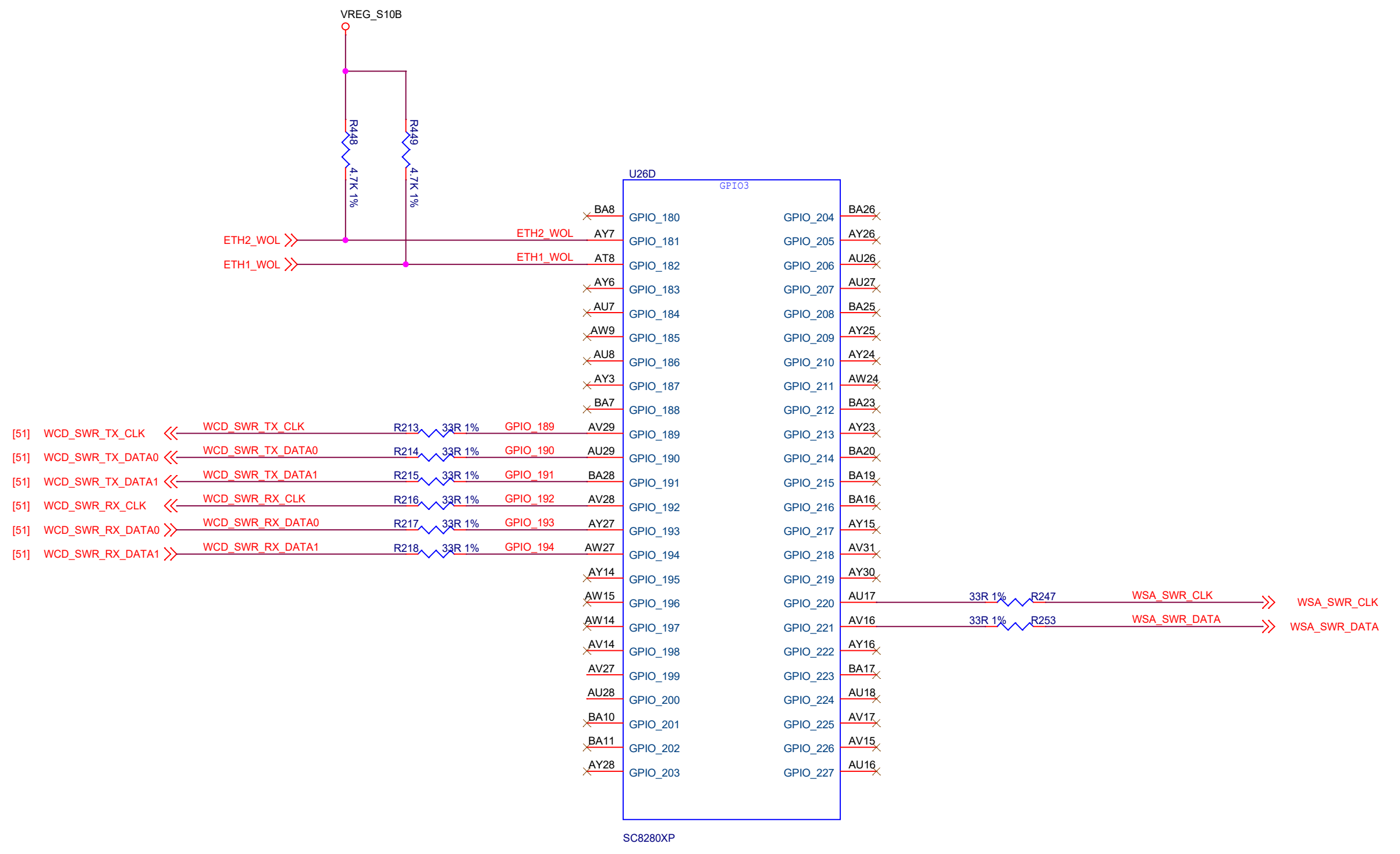

Size	Title: Radxa Dragon Q8	REV
C	Page Name: <Doc>	V1.3
Date:	Monday, June 22, 2026	Sheet 6 of 50

SC8280XP_EBI_0_3

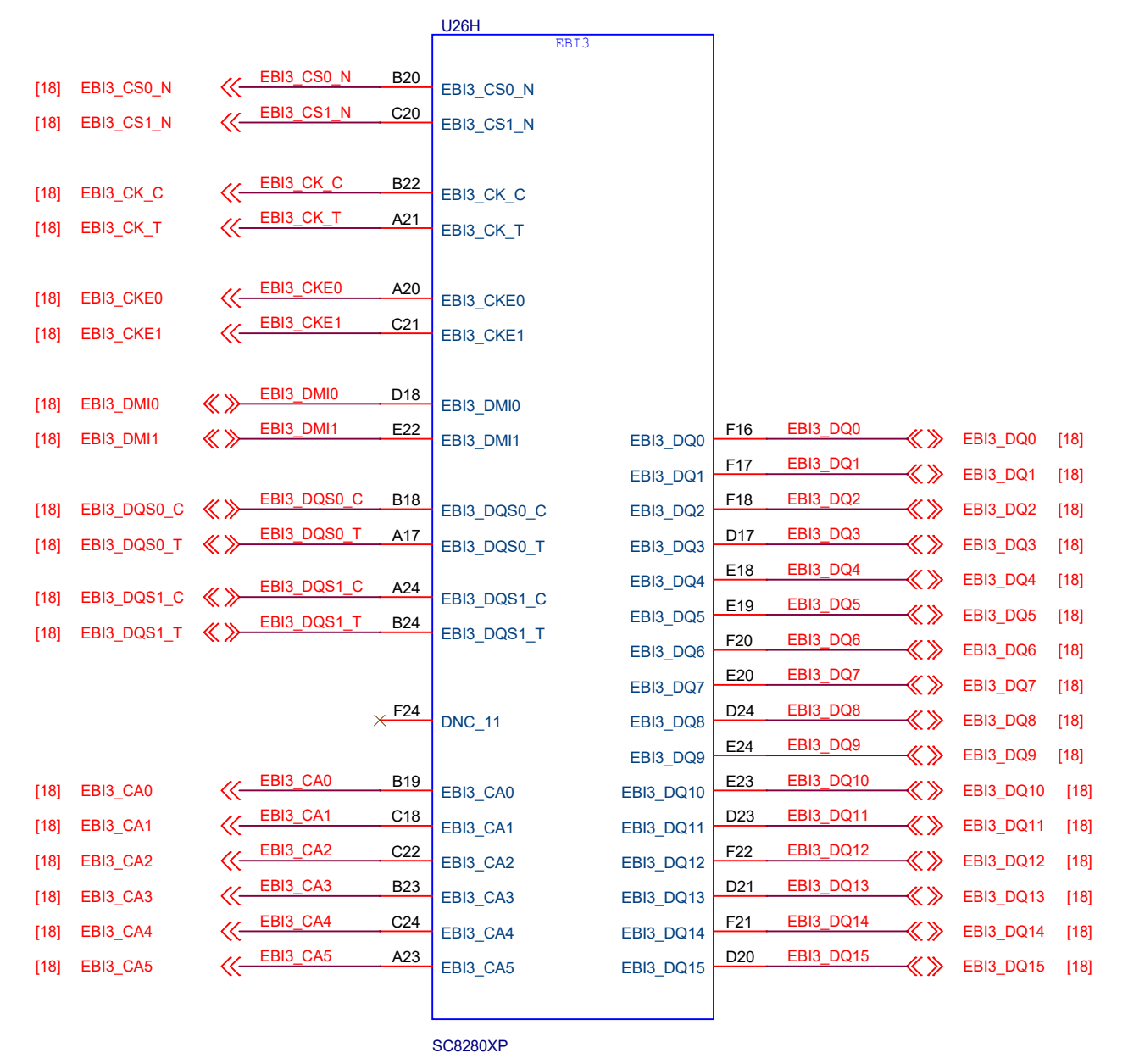
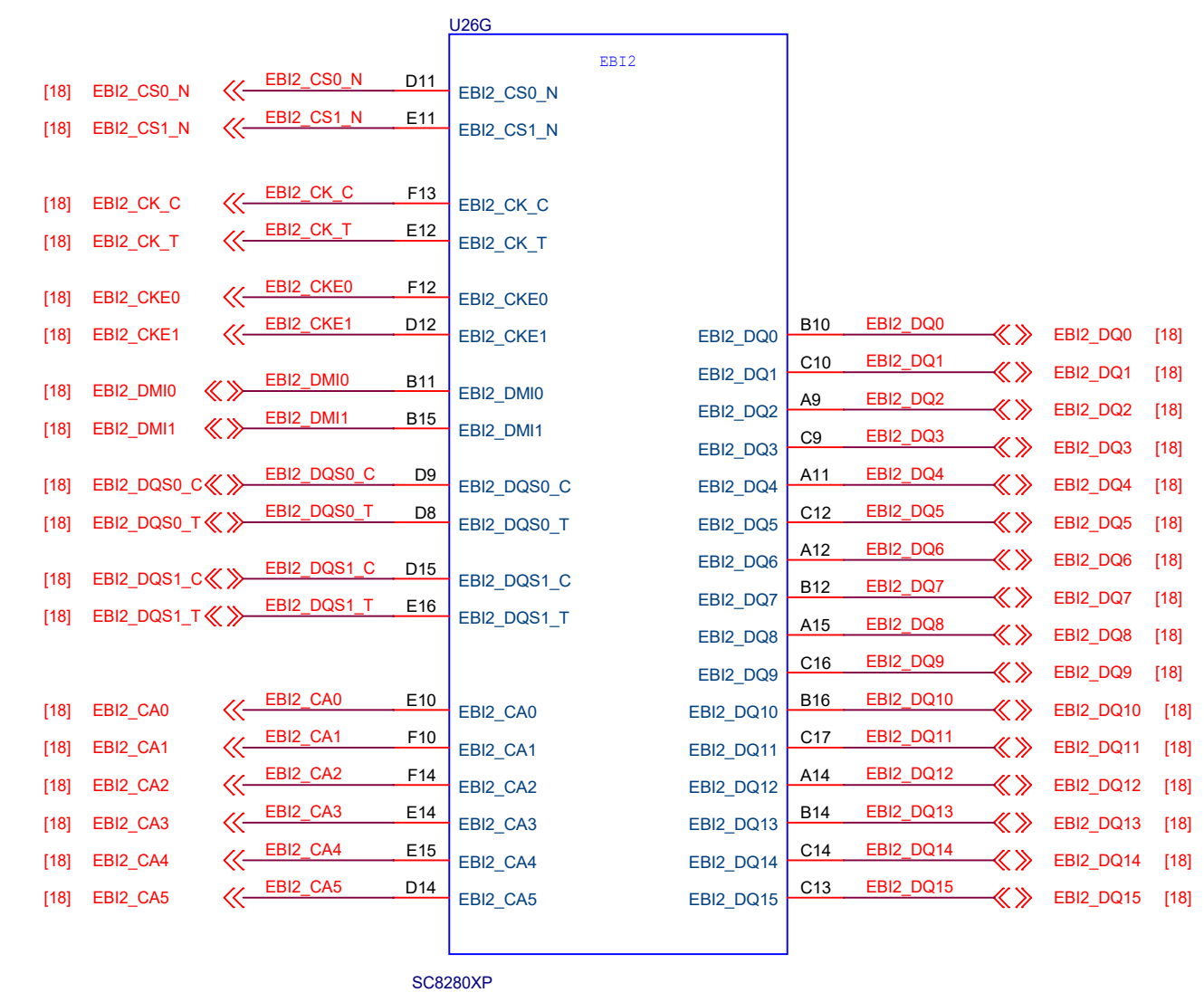
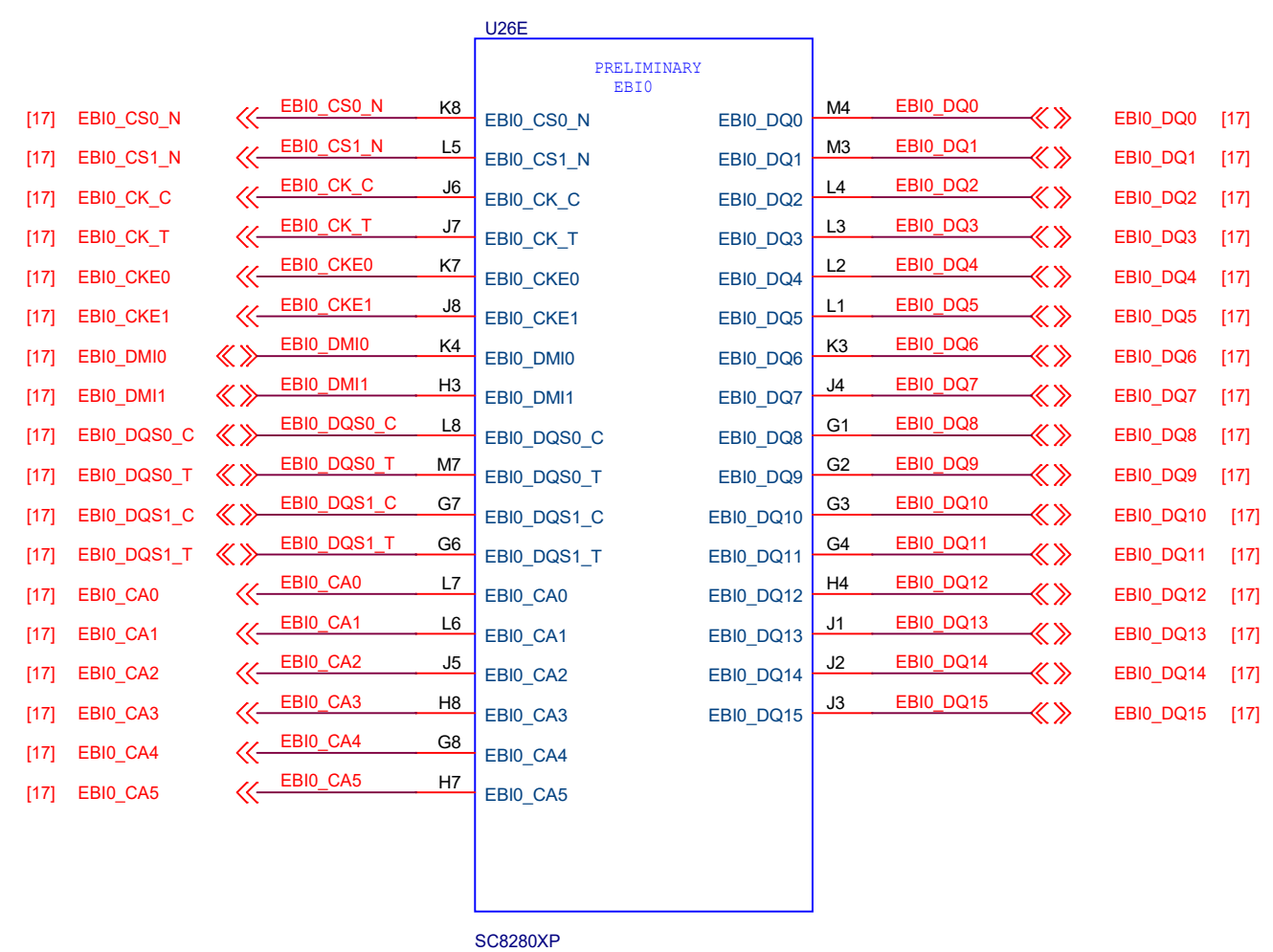

SC8280XP_EBI_4_7

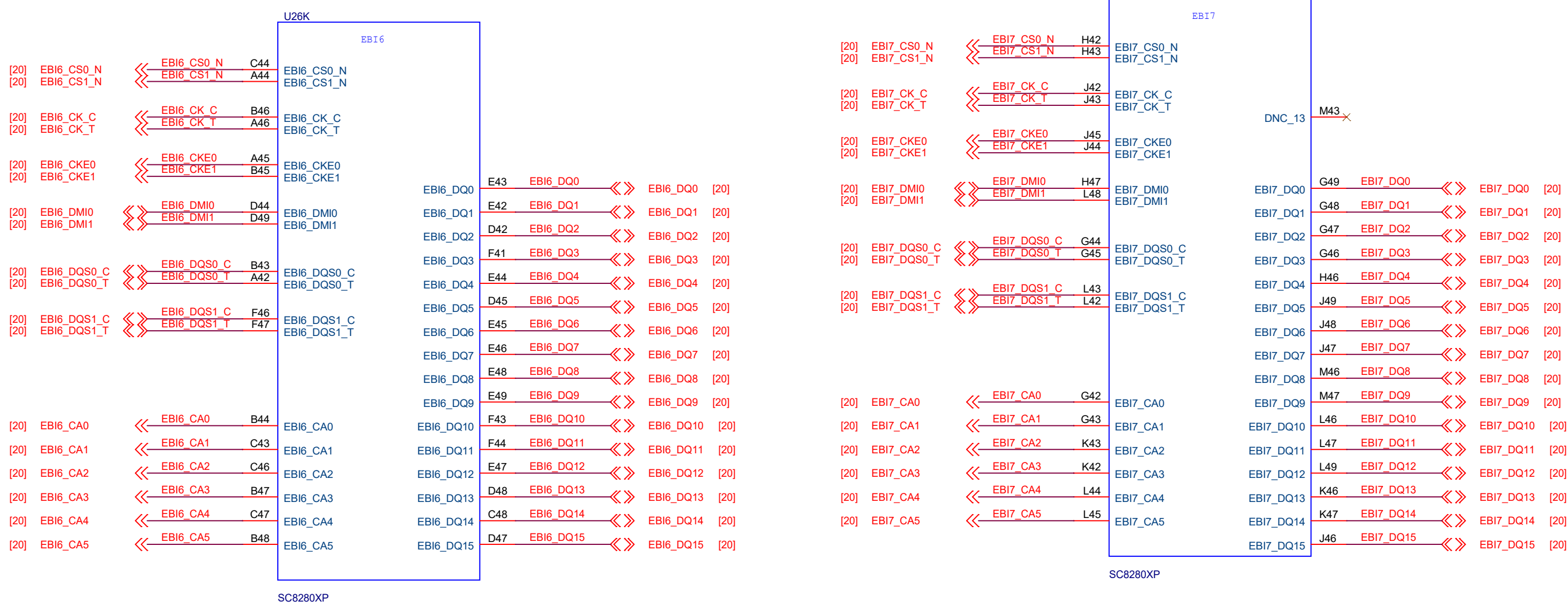
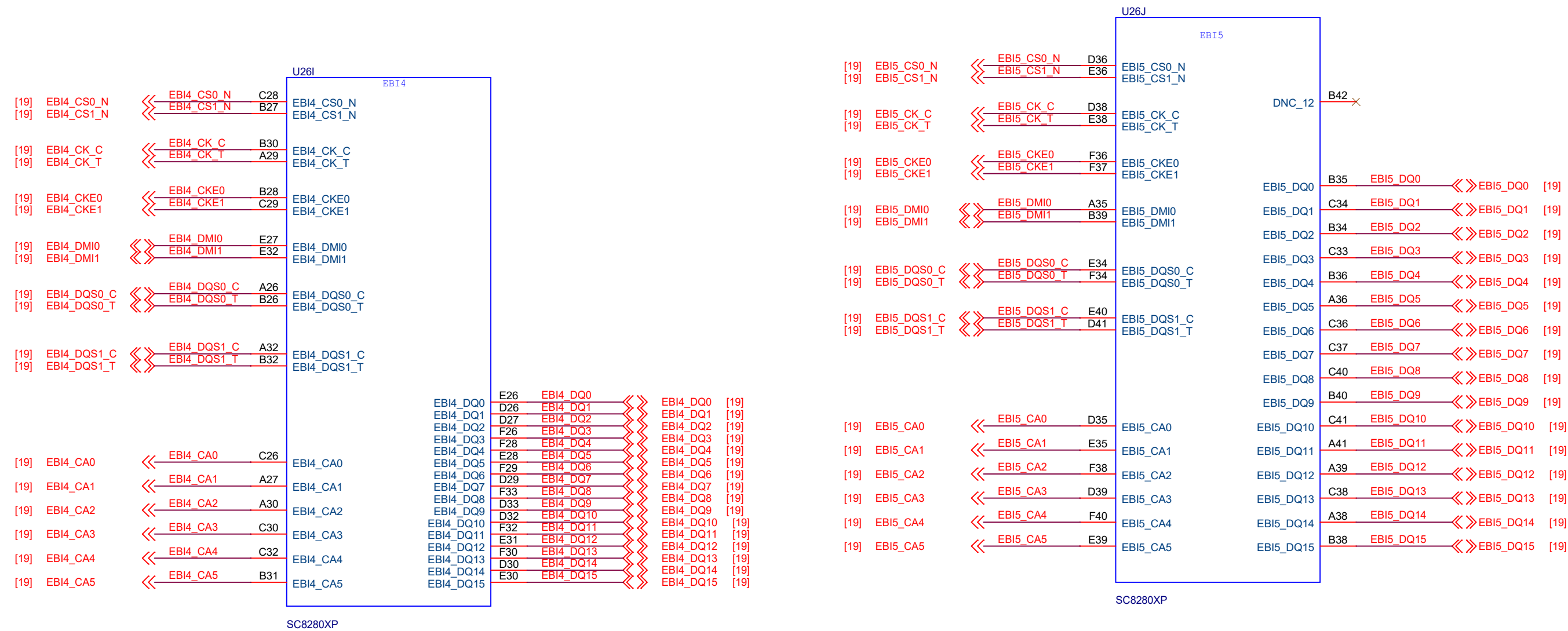

SC8280XP_SERDES1

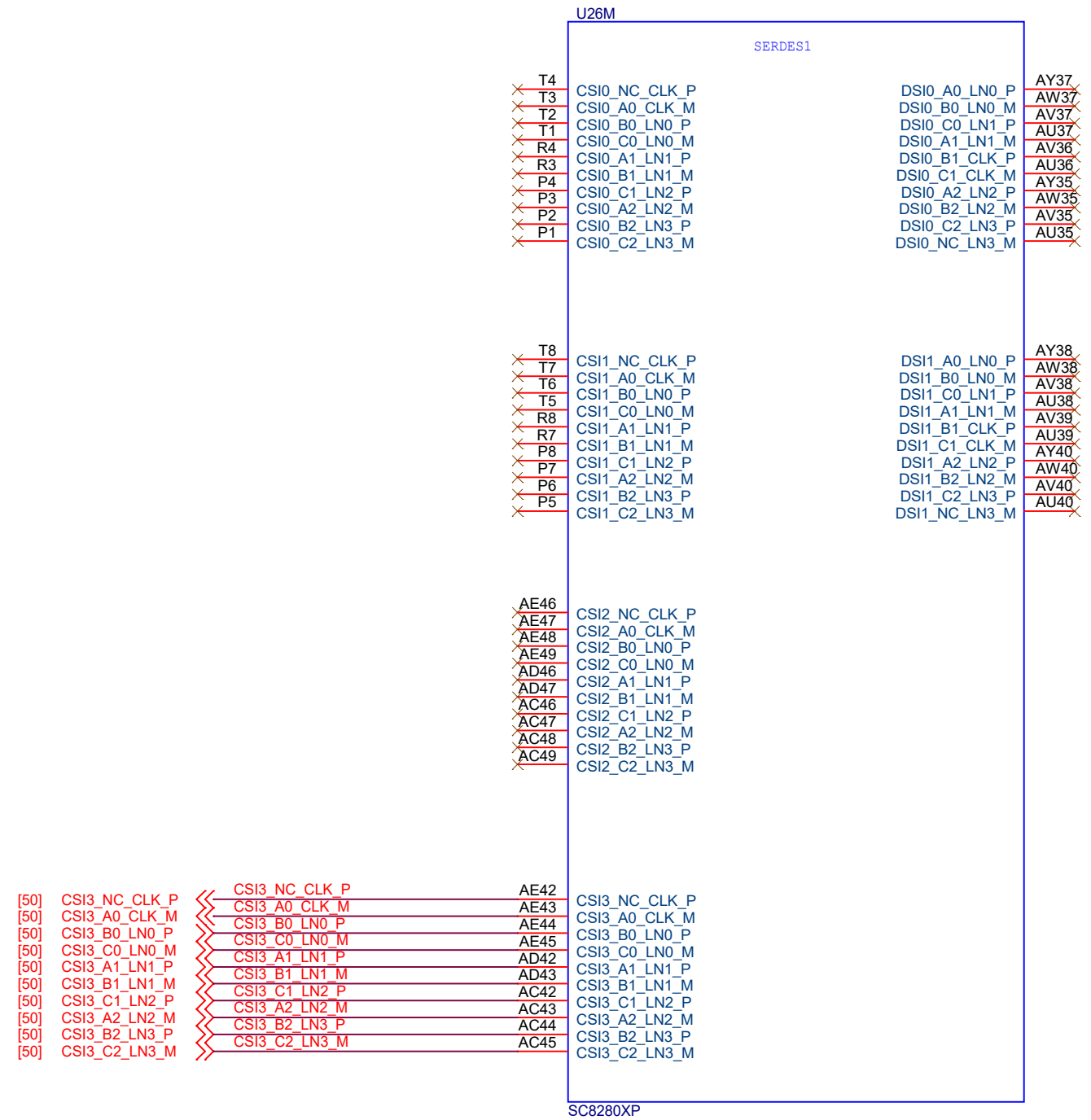

SC8280XP_SERDES2

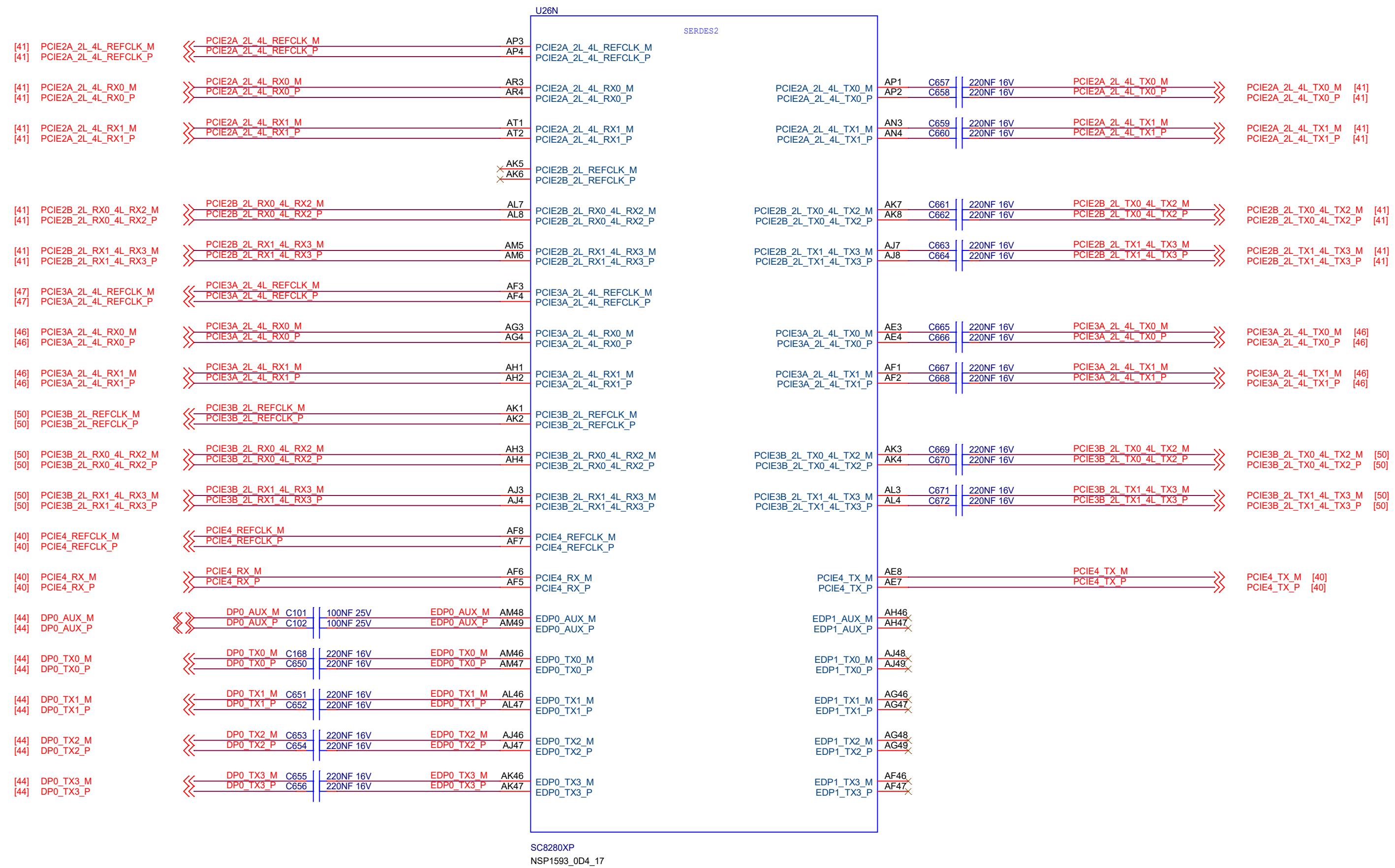

Size	Title: Radxa Dragon Q8	REV
C	Page Name: <Doc>	V1.3
Date:	Monday, June 22, 2026	Sheet 10 of 50

SC8280XP_SERDES3

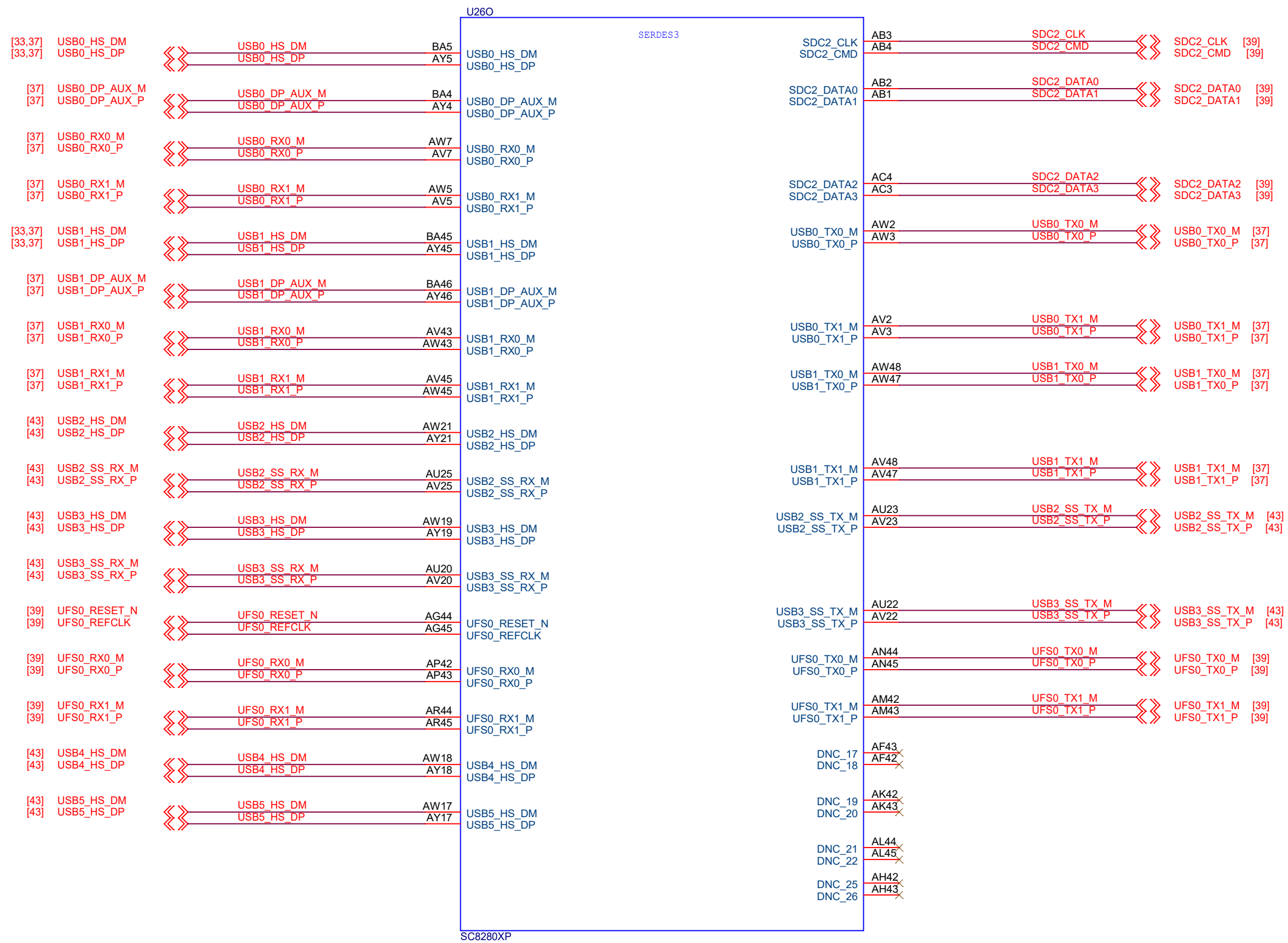

SC8280XP_PWR1

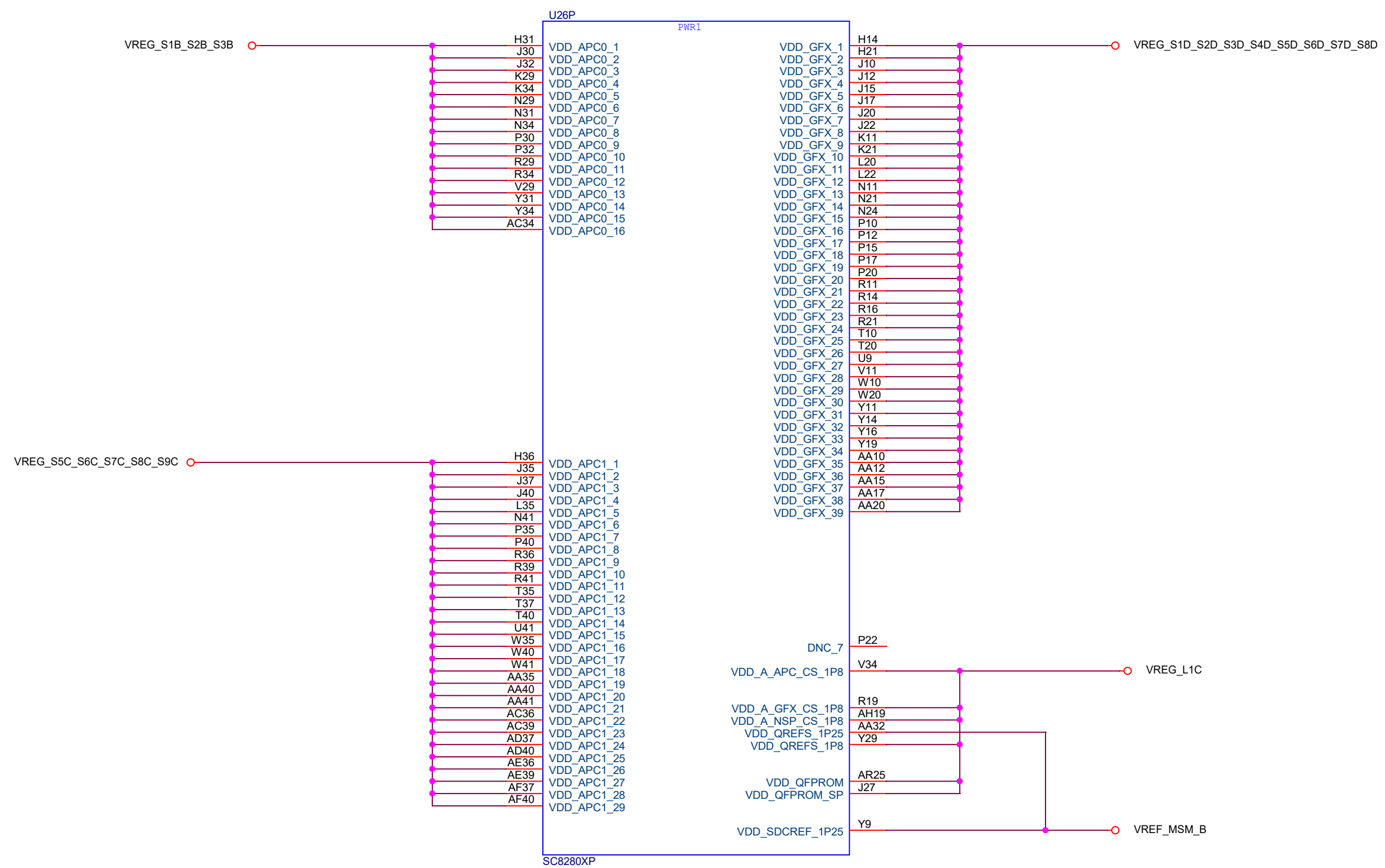

Size	Title: Radxa Dragon Q8	REV
C	Page Name: <Doc>	V1.3
Date:	Monday, June 22, 2026	Sheet 12 of 50

SC8280XP_PWR2

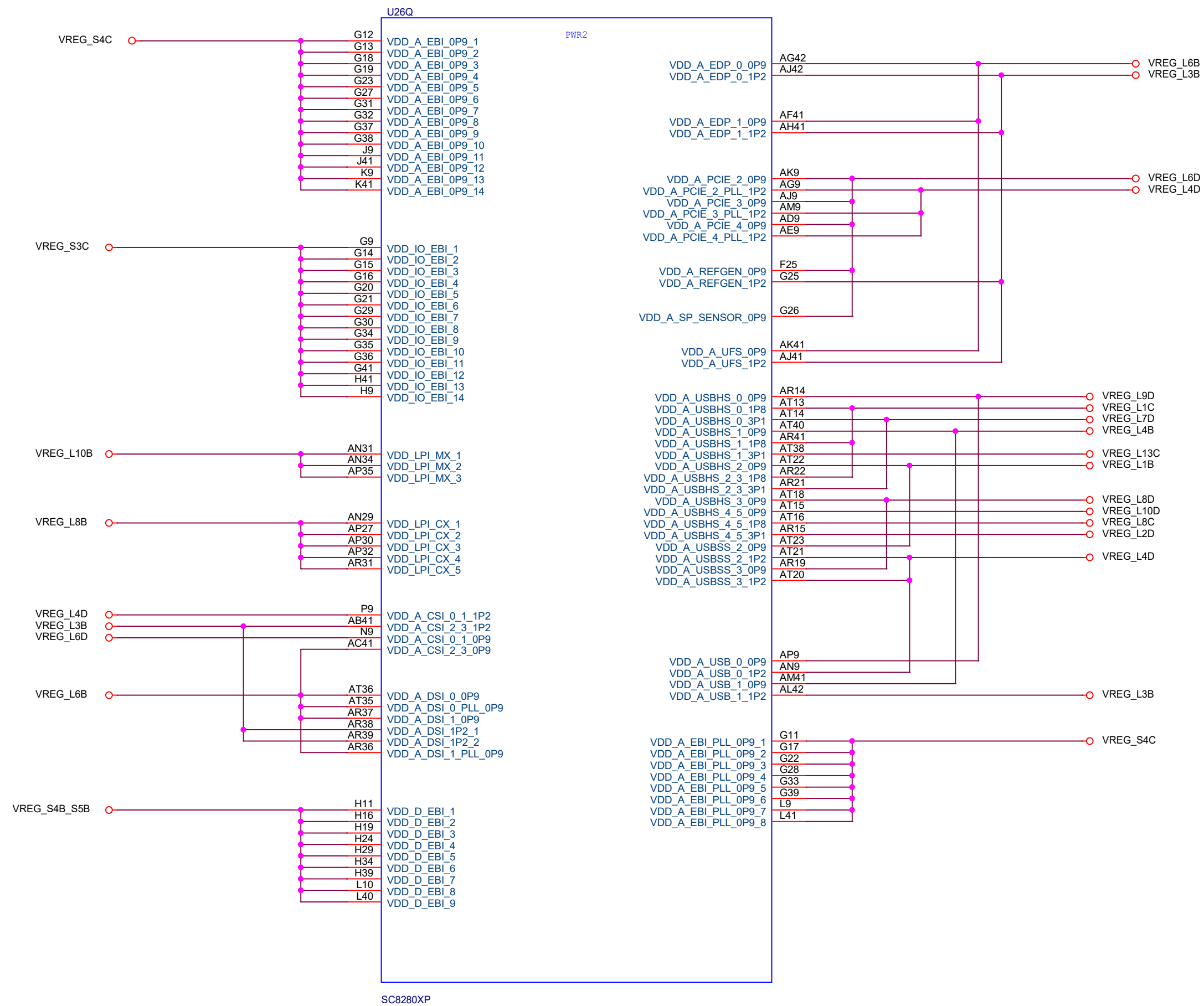

Size	Title: Radxa Dragon Q8	REV
C	Page Name: <Doc>	V1.3
Date:	Monday, June 22, 2026	Sheet 13 of 50

SC8280XP_PWR3

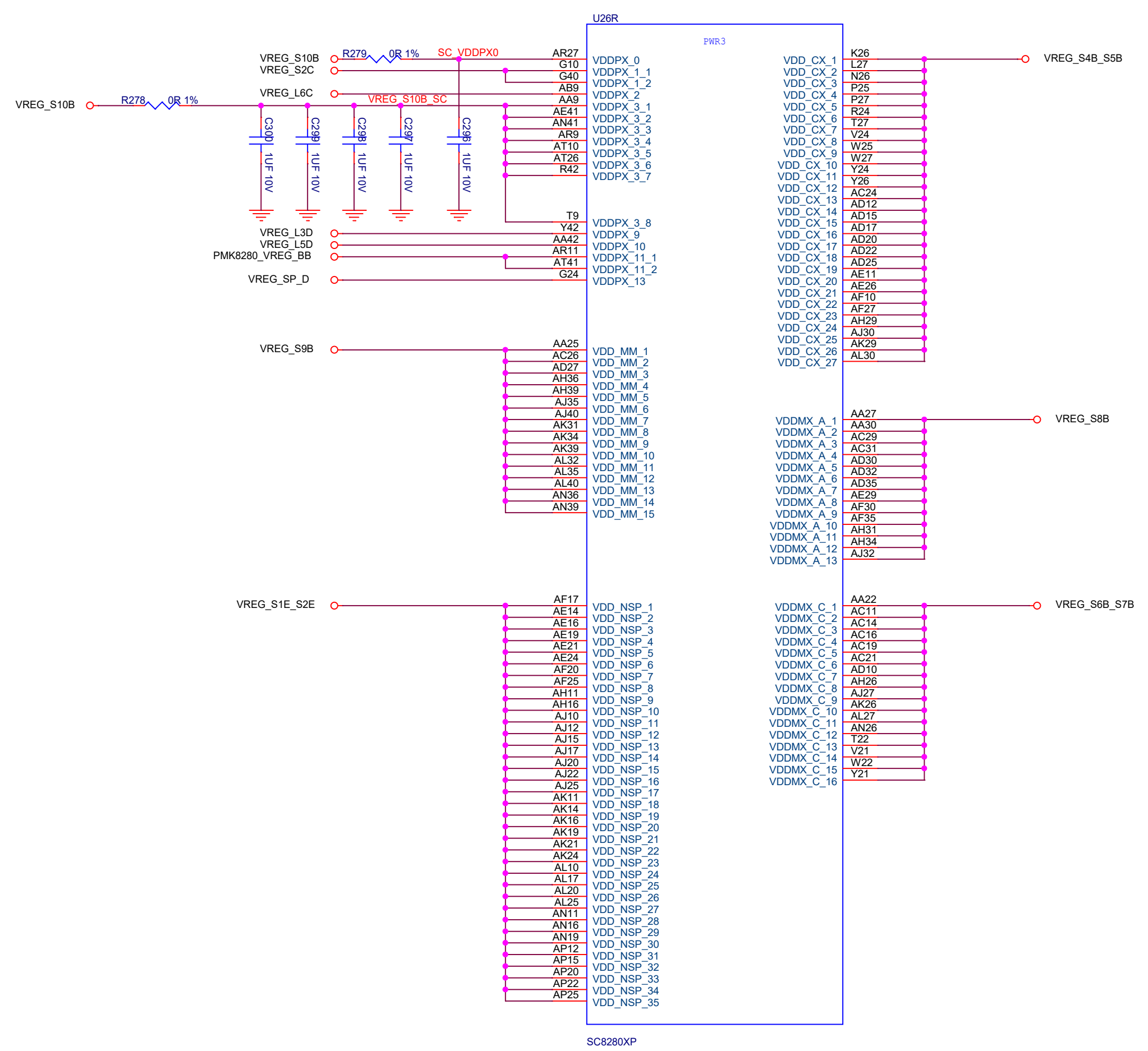

Size	Title: Radxa Dragon Q8	REV
C	Page Name: <Doc>	V1.3
Date:	Monday, June 22, 2026	Sheet 14 of 50

SC8280XP_GND

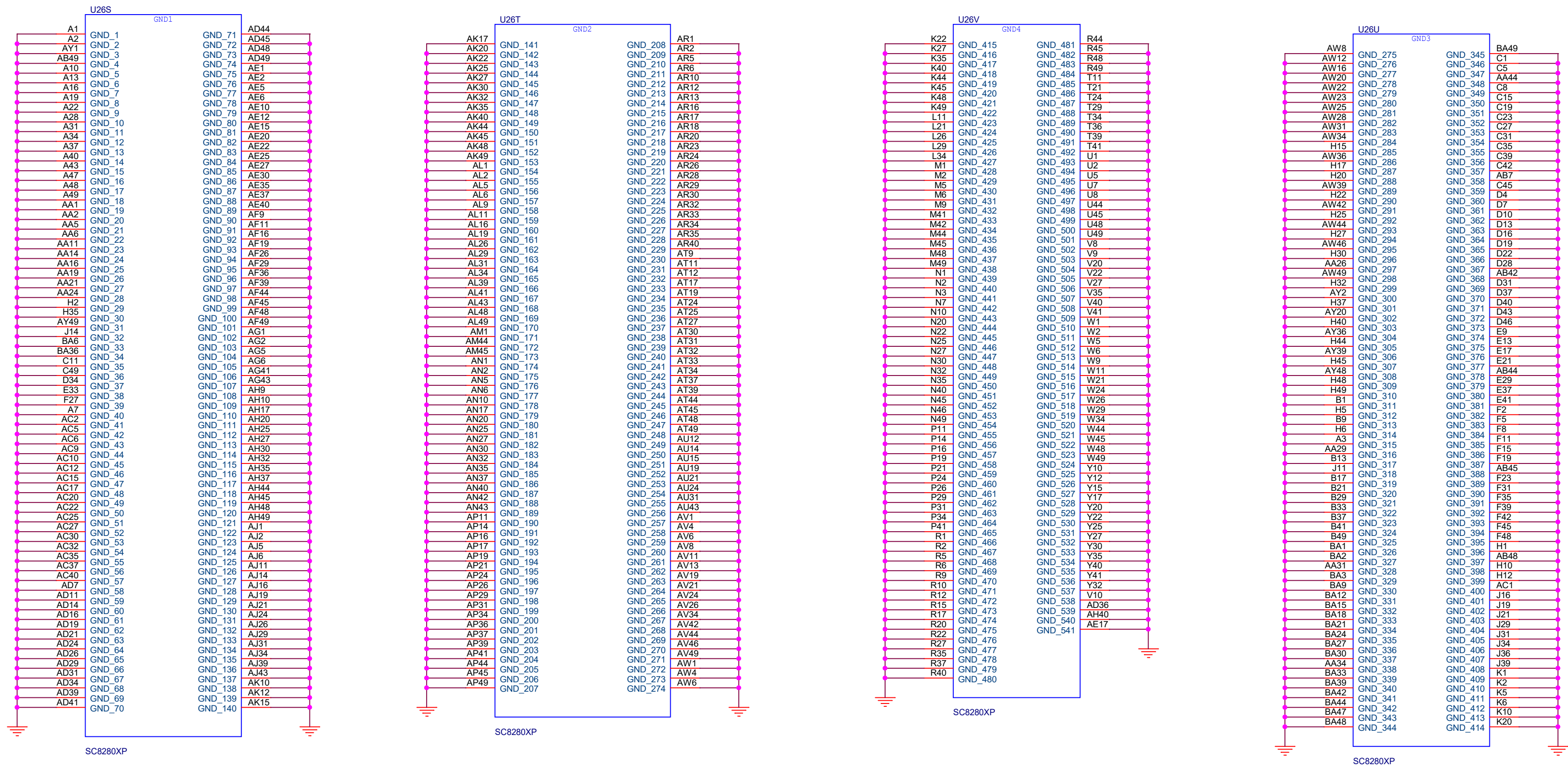

Size	Title: Radxa Dragon Q8	REV
C	Page Name: <Doc>	V1.3
Date: Monday, June 22, 2026	Sheet 15 of 50	

LPDDR4X_EBI2_3

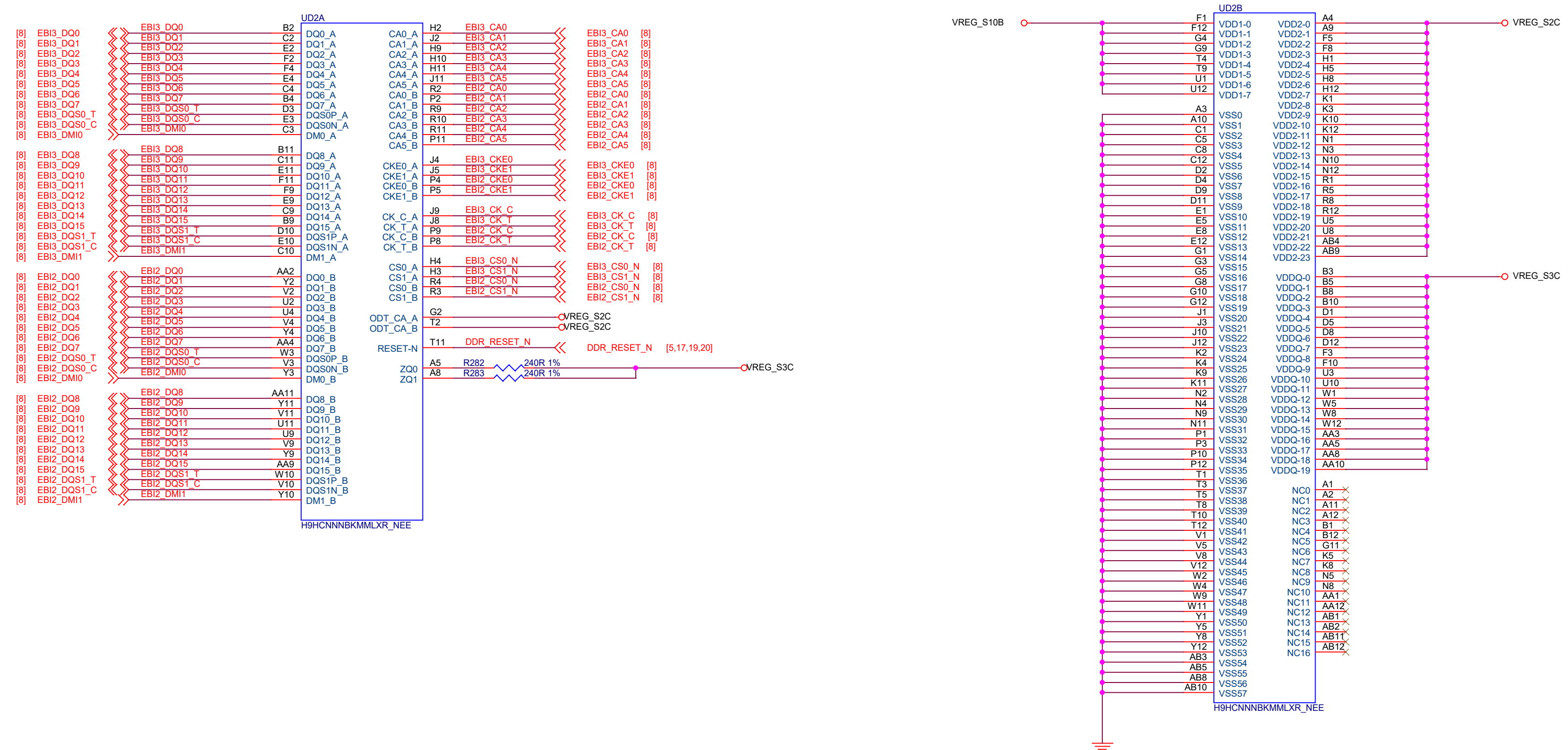

LPDDR4X_EBI4_5

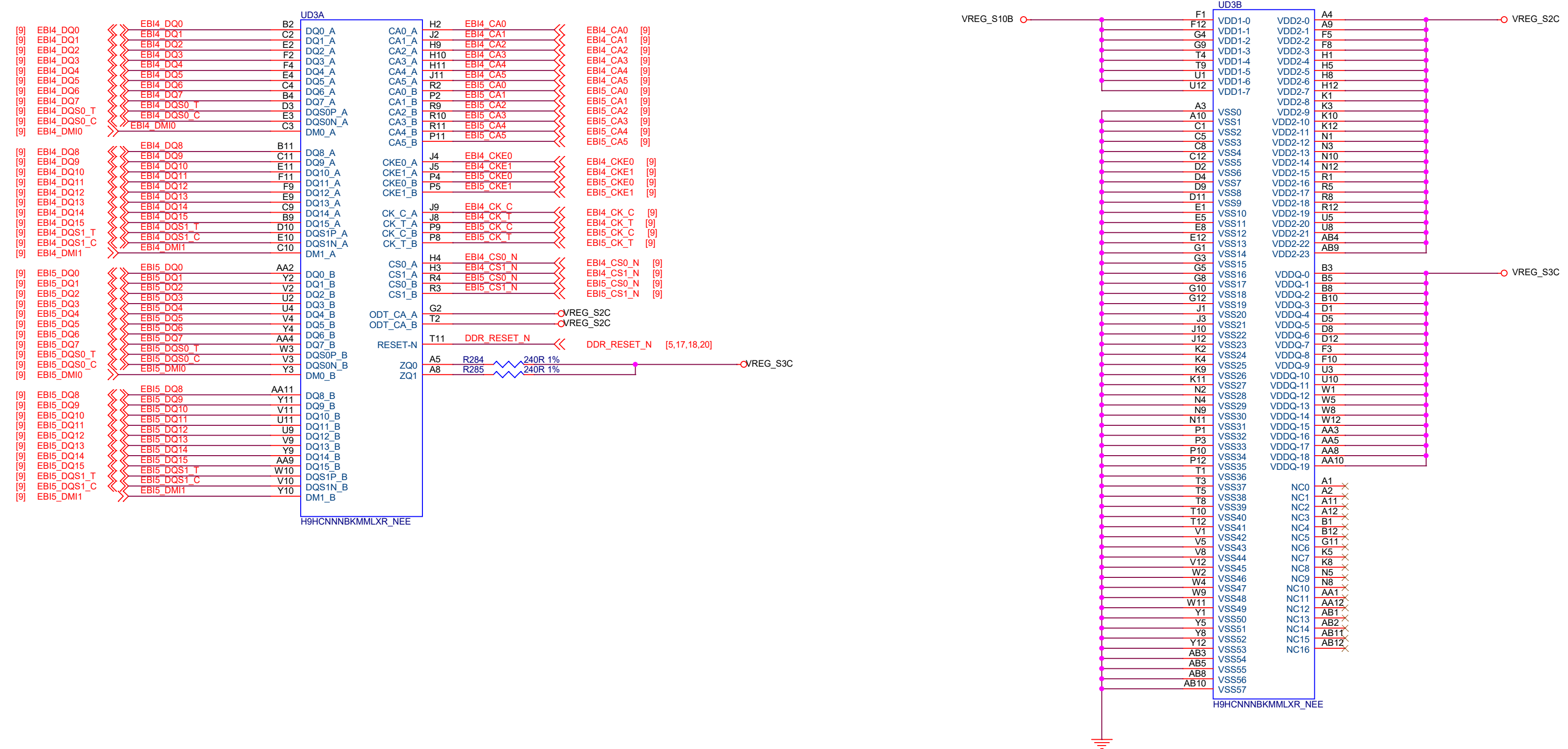

LPDDR4X_EBI6_7

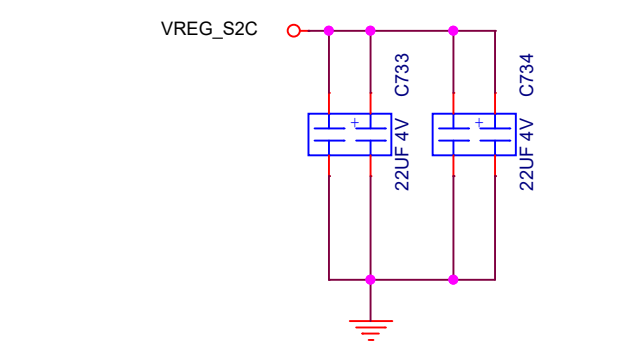
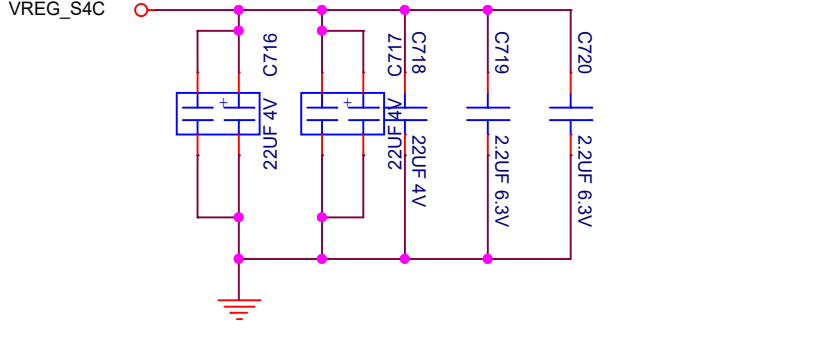
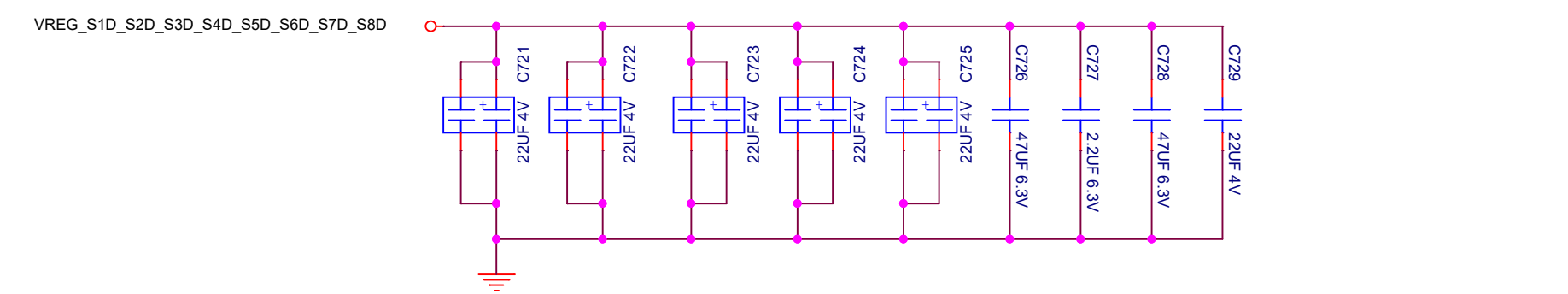
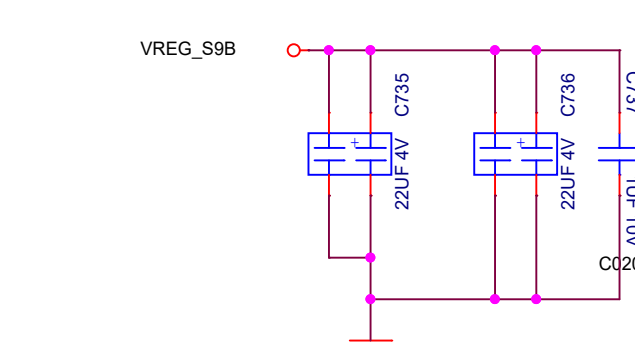
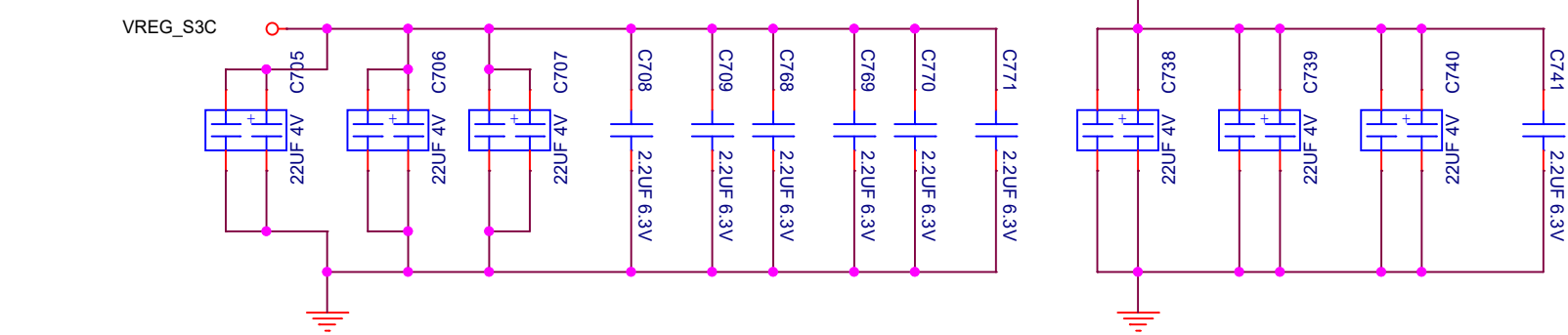
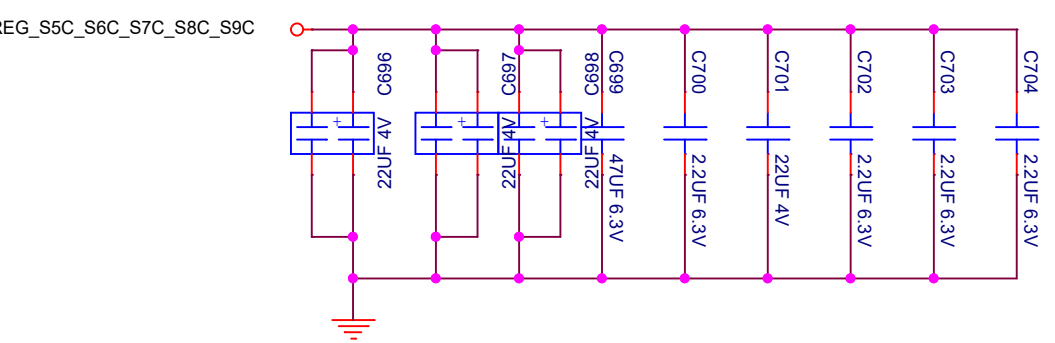
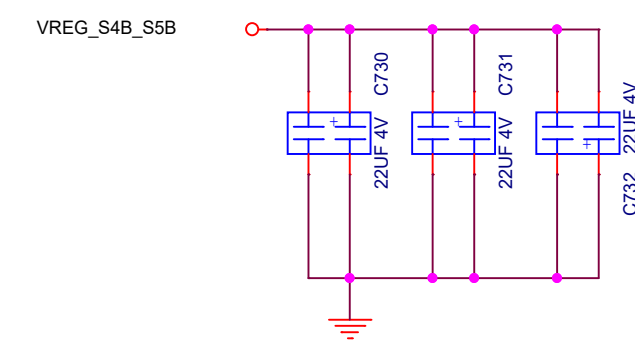
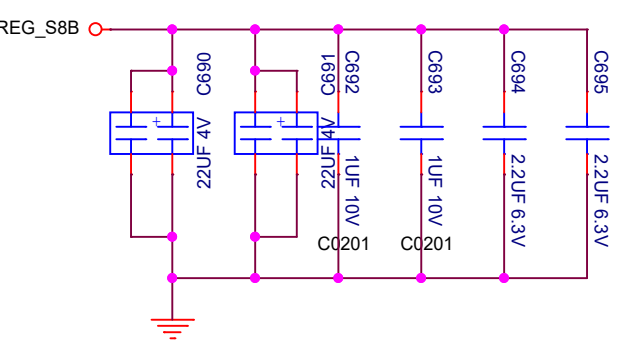
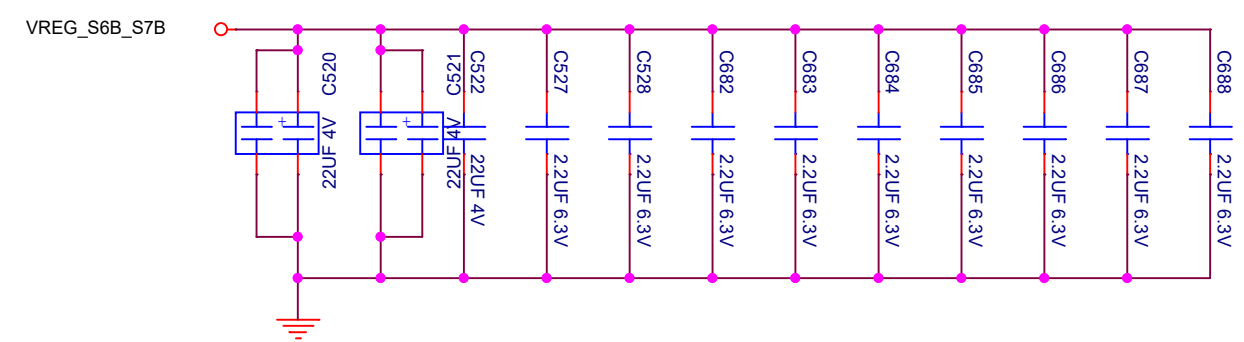
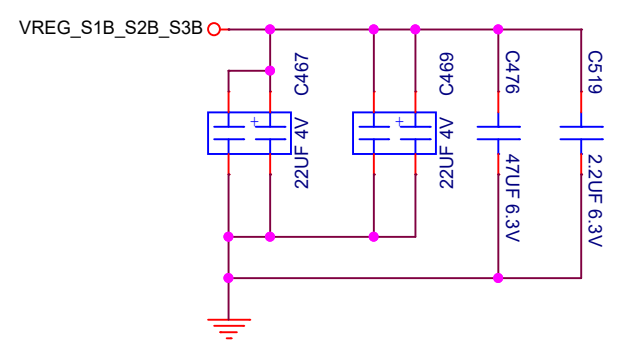
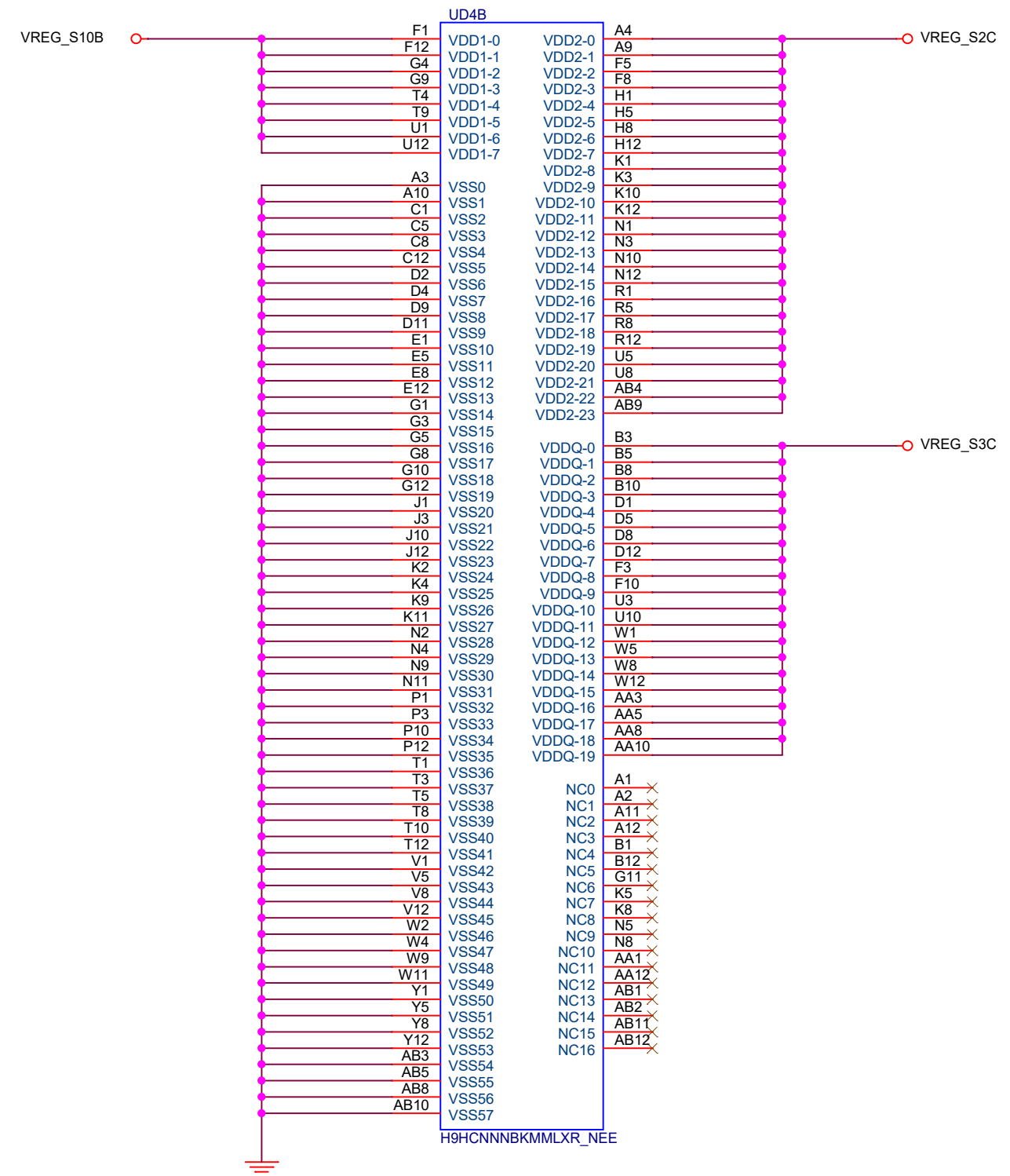
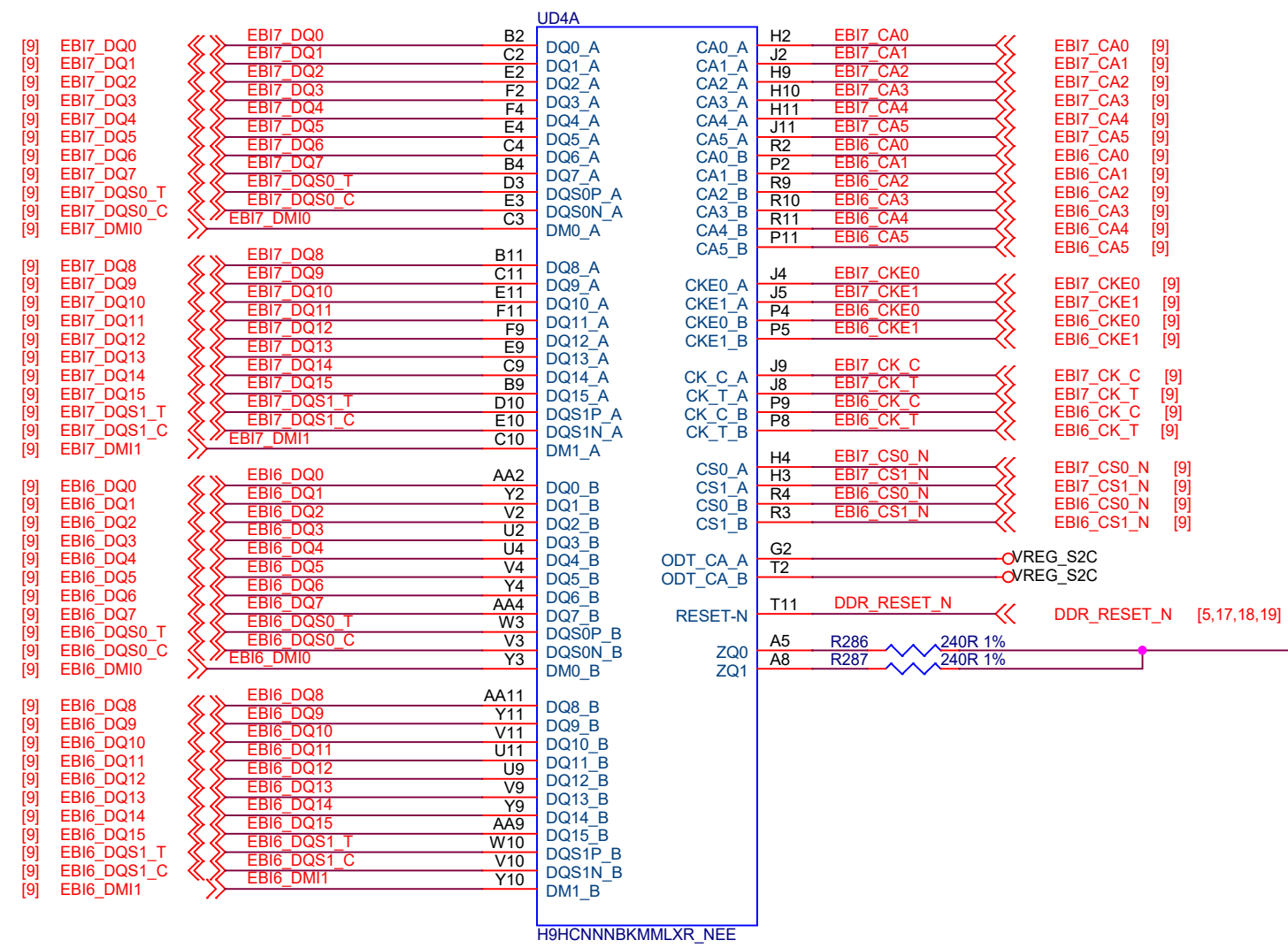

SC8280XP_DECAP

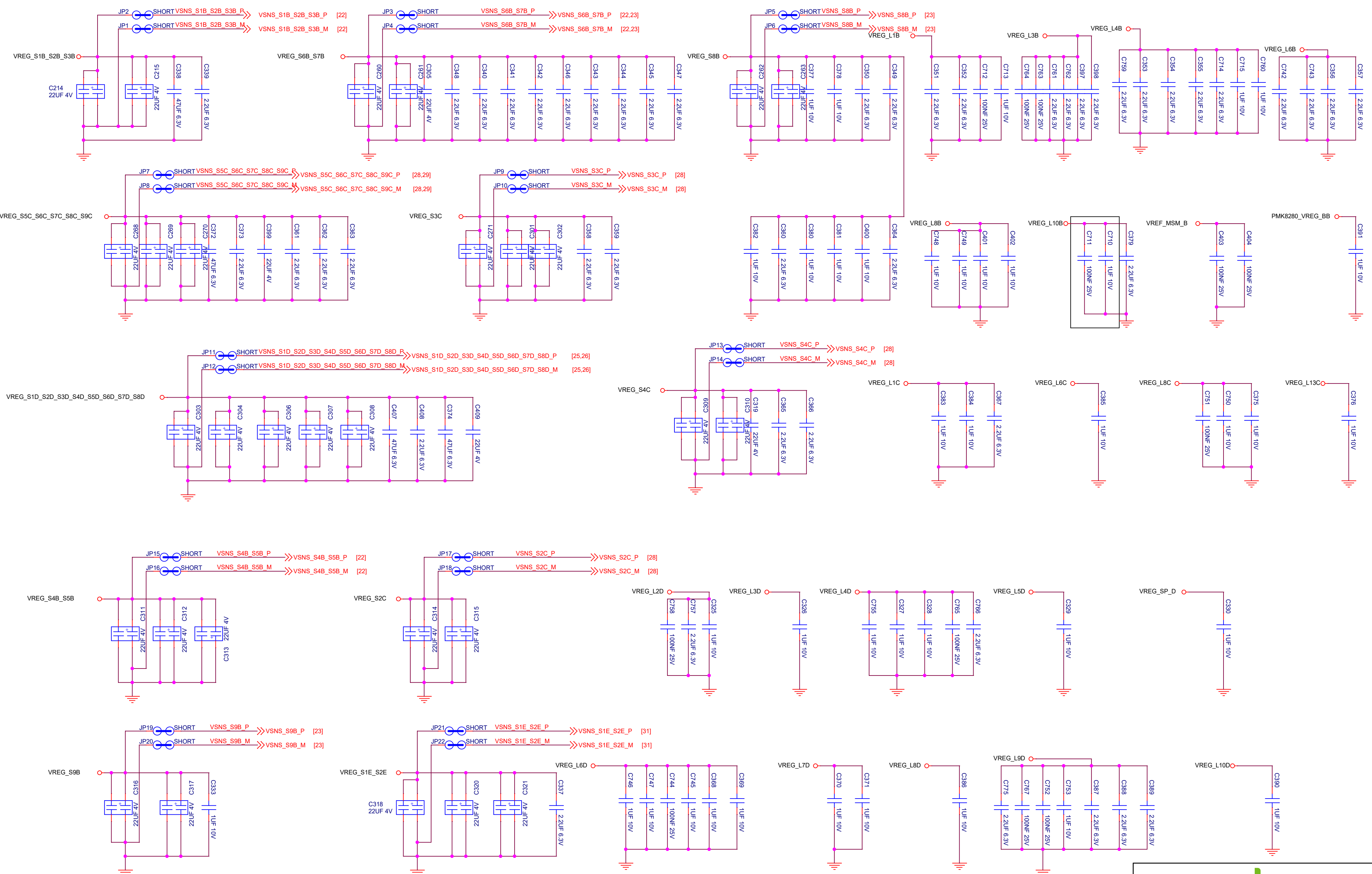

Size	Title: Radxa Dragon Q8	REV
C	Page Name: <Doc>	V1.3
Date: Monday, June 22, 2026	Sheet 20 of 50	

MC8280_1_BUCK_S1_S6

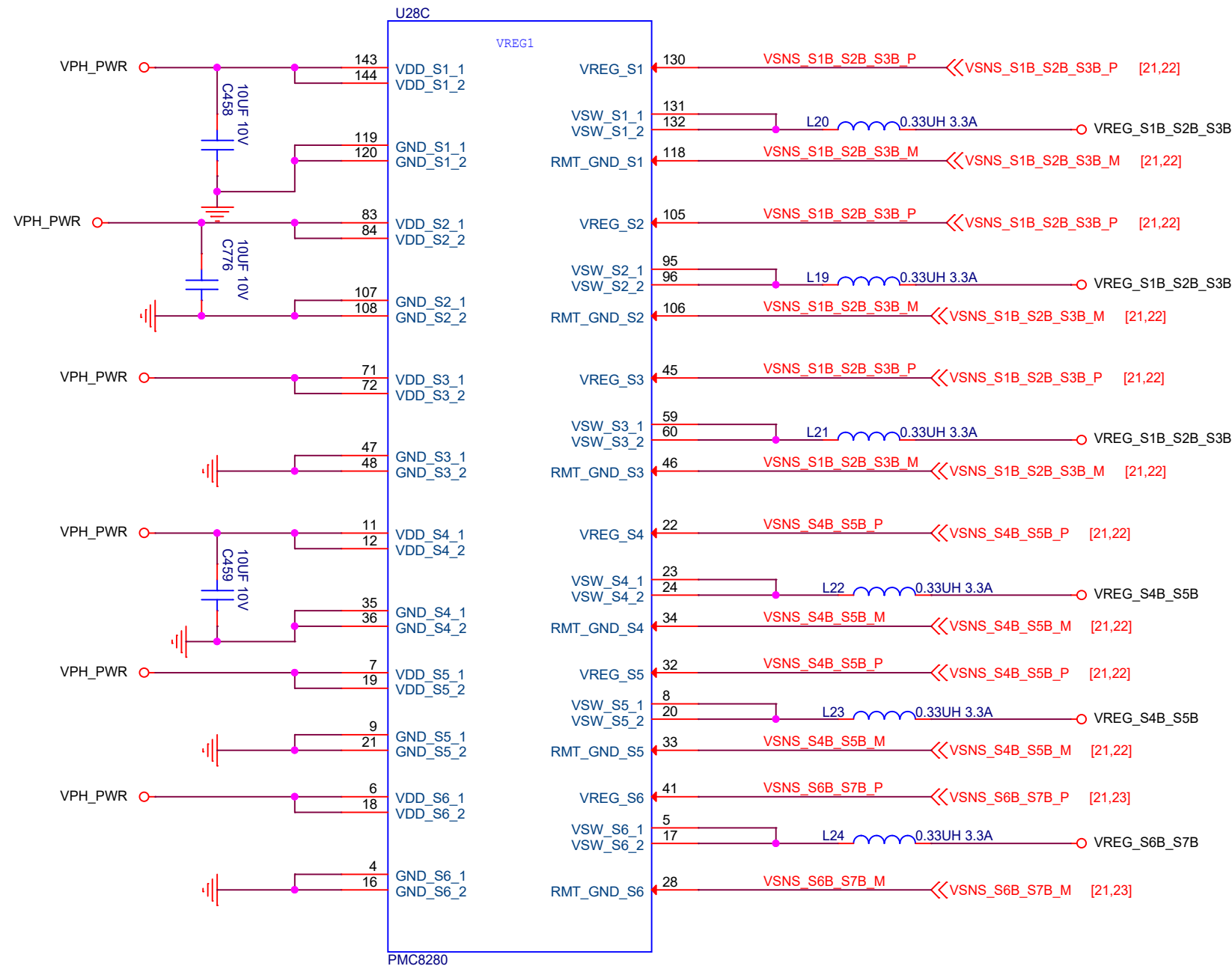

PMC8280_1_BUCK_S7_S12

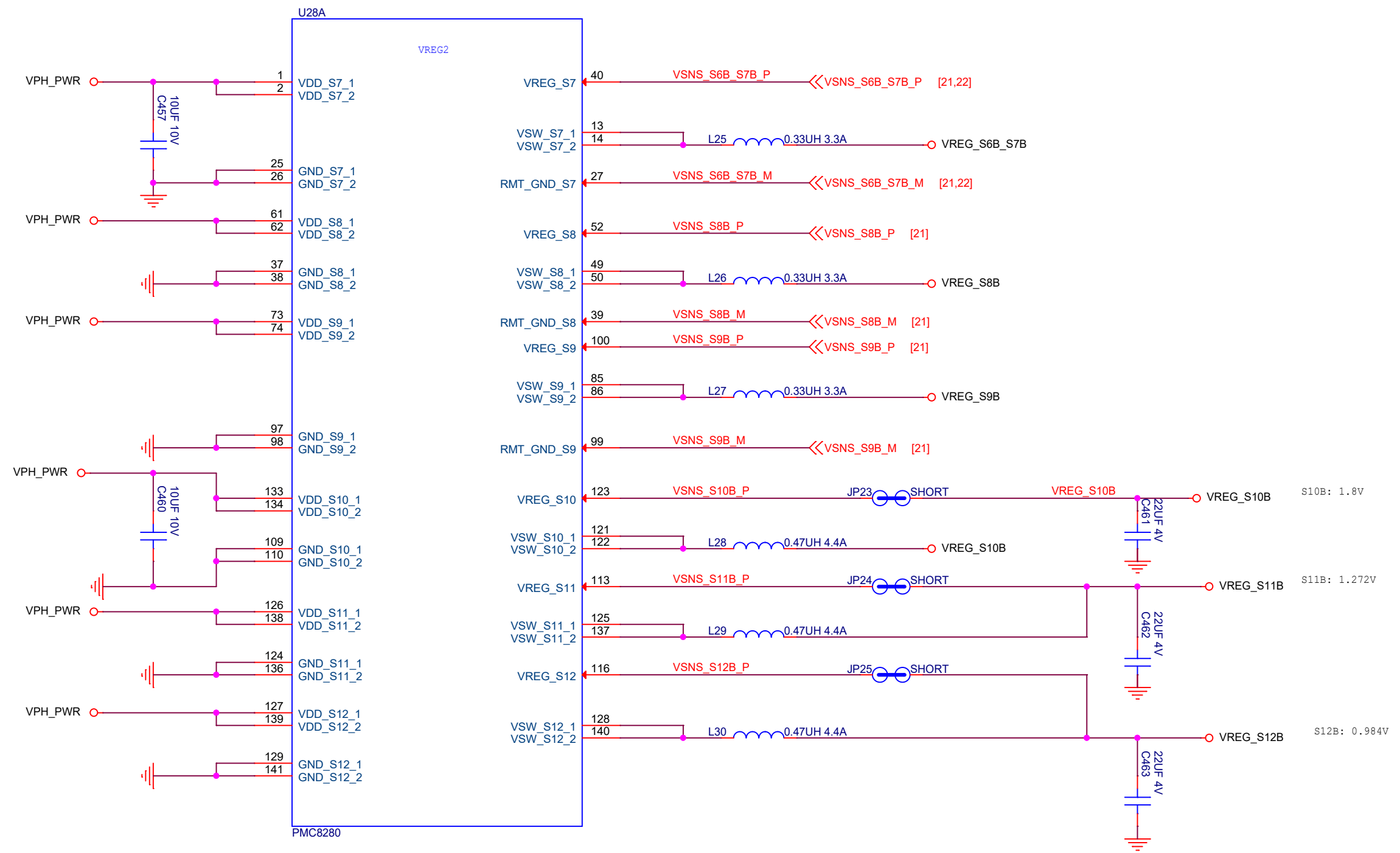

Size	Title: Radxa Dragon Q8	REV
C	Page Name: <Doc>	V1.3
Date:	Monday, June 22, 2026	Sheet 22 of 50

PMC8280_1_HK/IO/GND/LDO

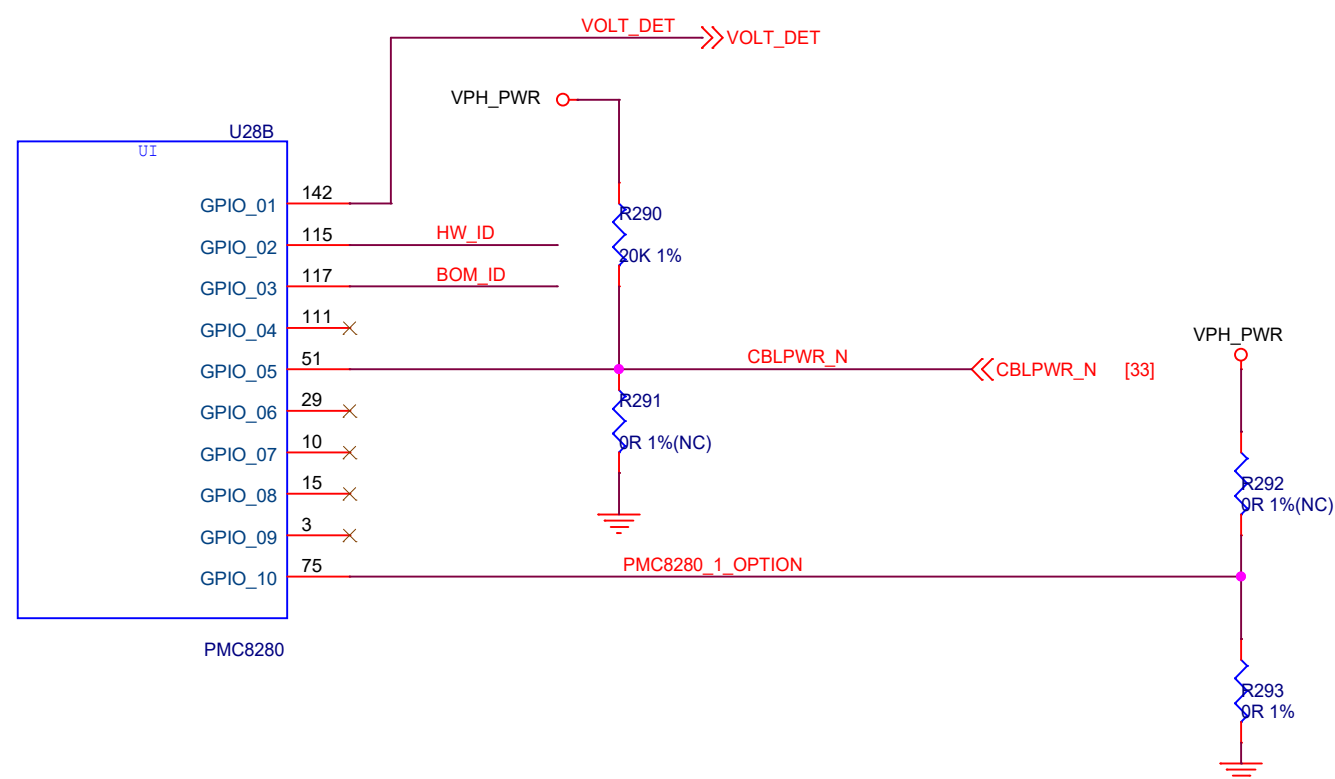
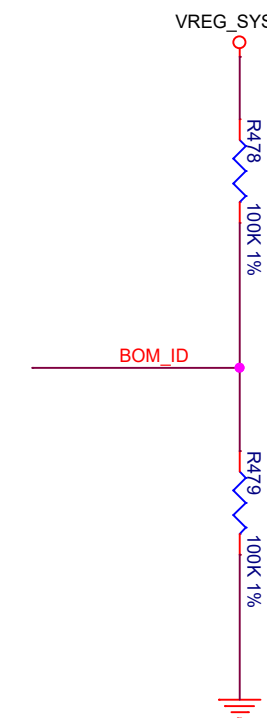
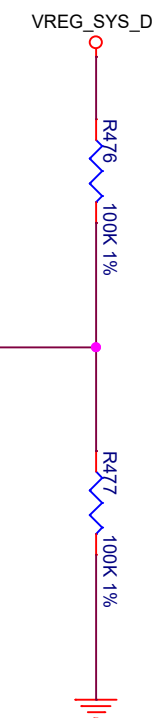
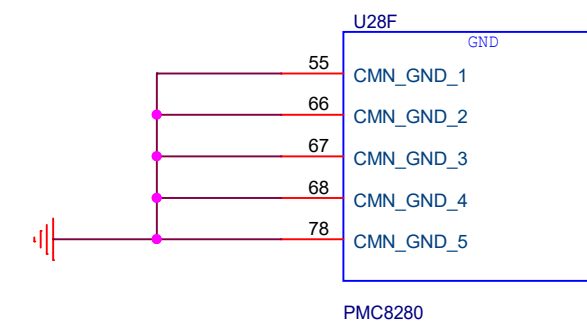
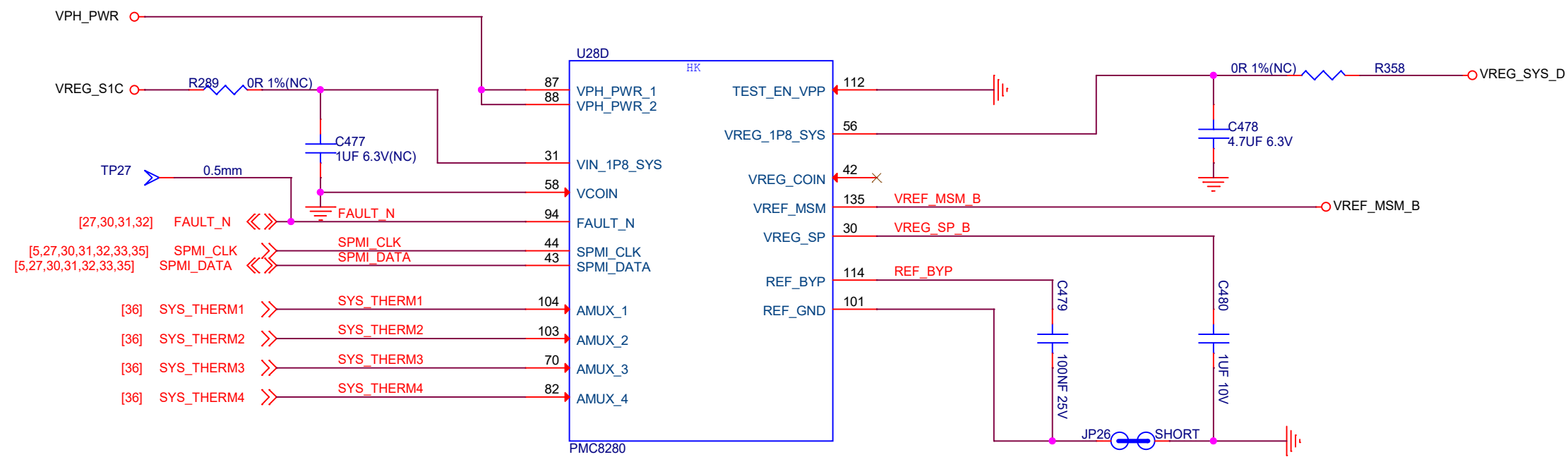
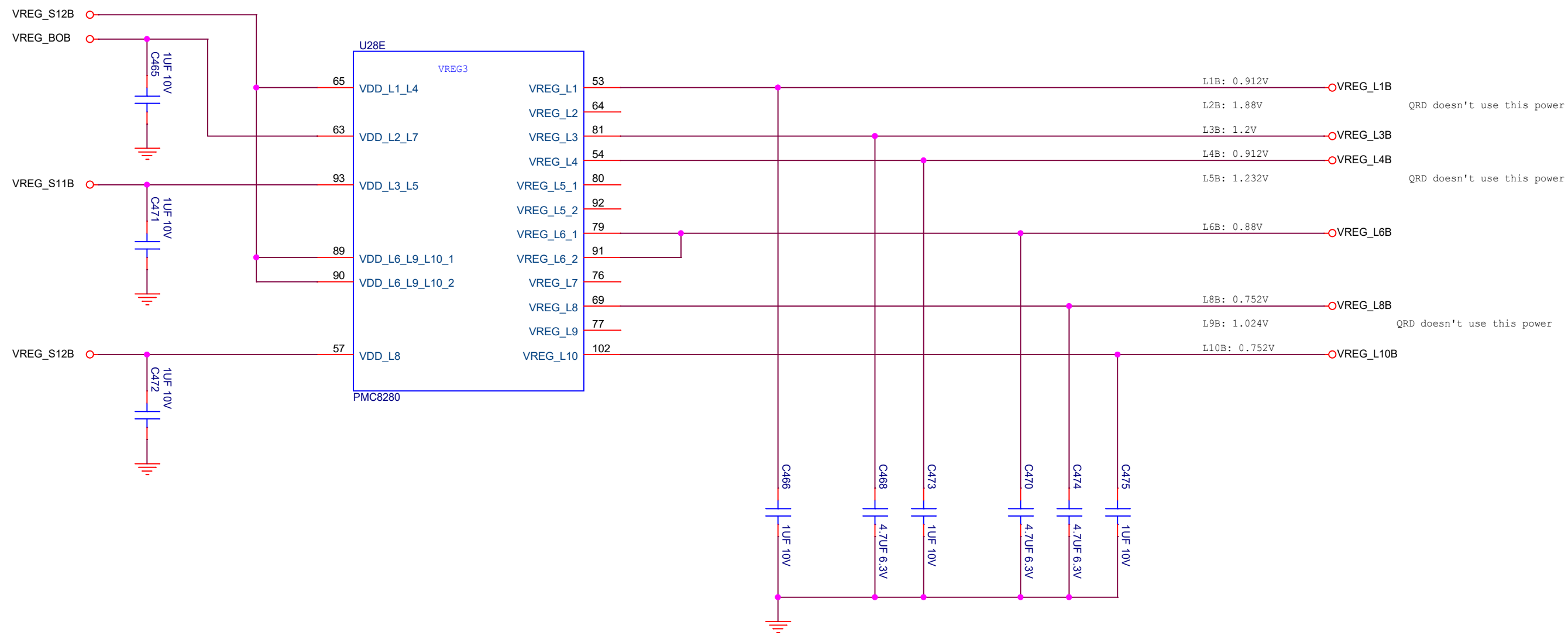

PMC8280_2_BUCK_S7_S12

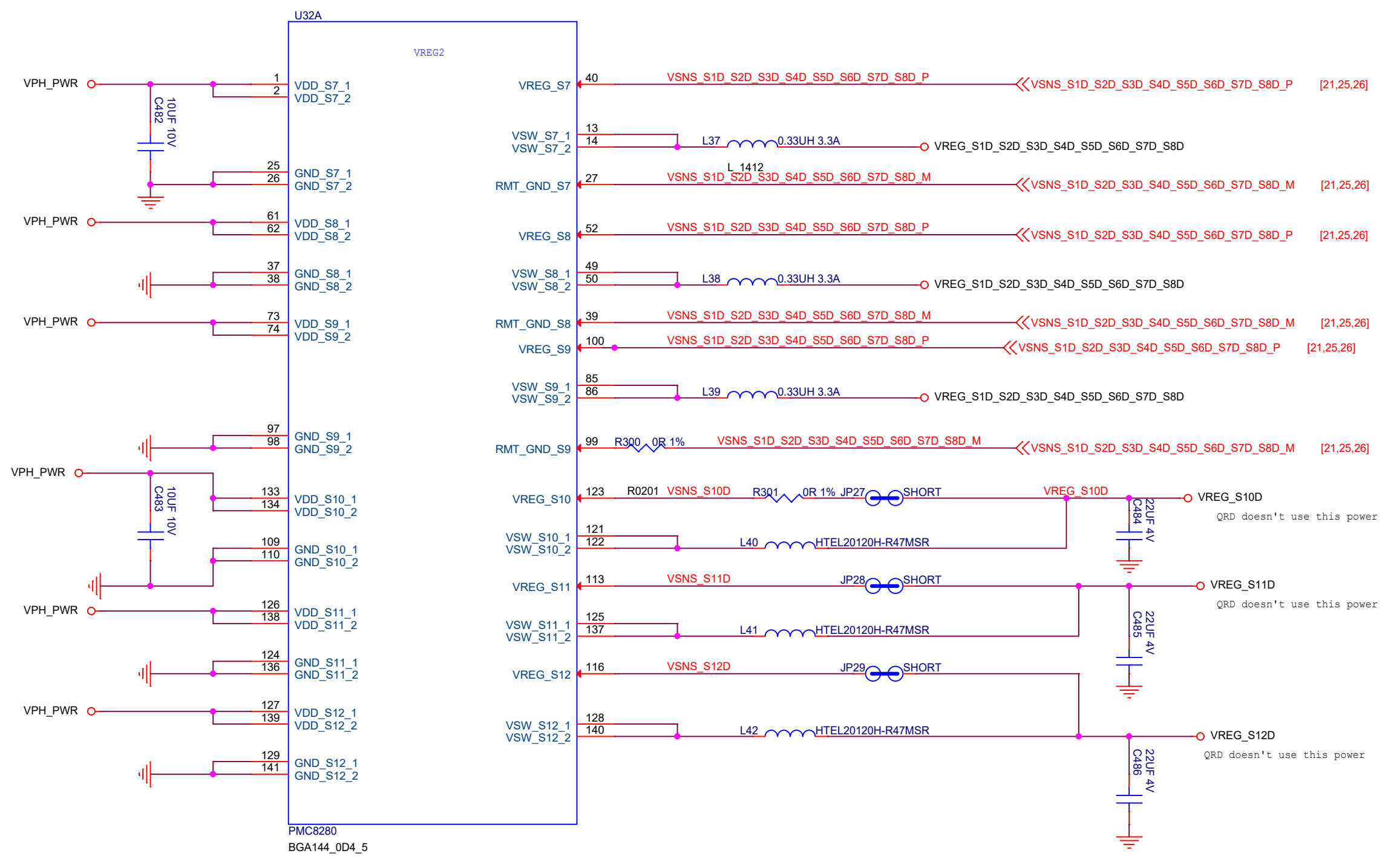

Size	Title: Radxa Dragon Q8	REV
C	Page Name: <Doc>	V1.3
Date:	Monday, June 22, 2026	Sheet 25 of 50

PMC8280_2_HK/IO/GND/LDO

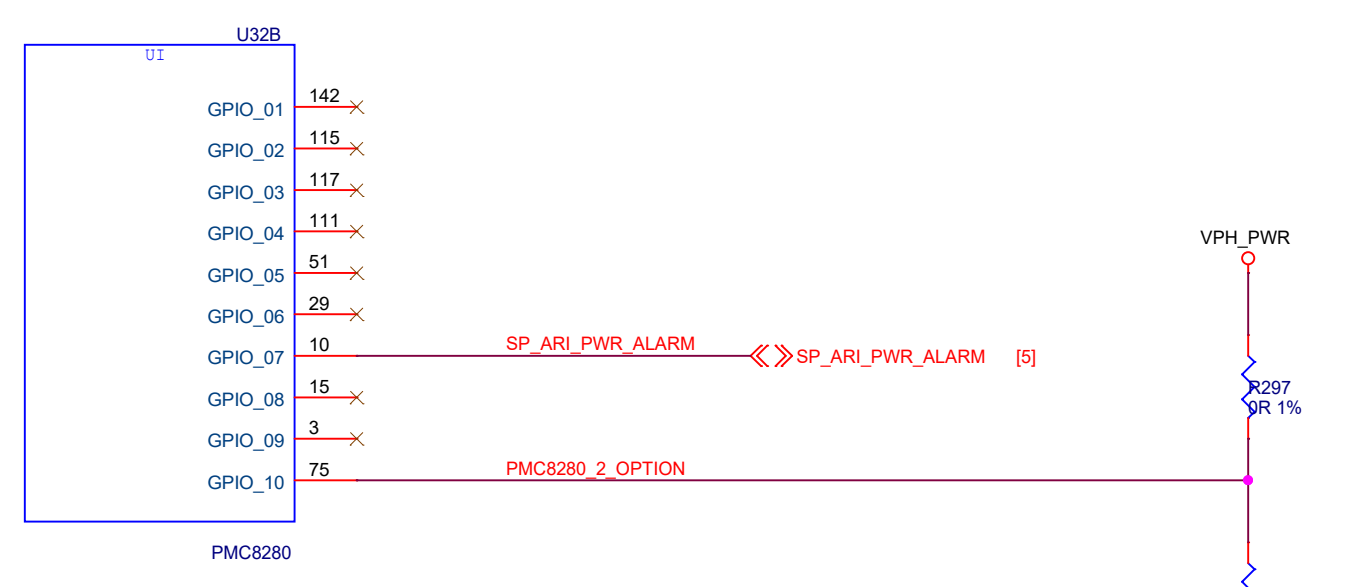
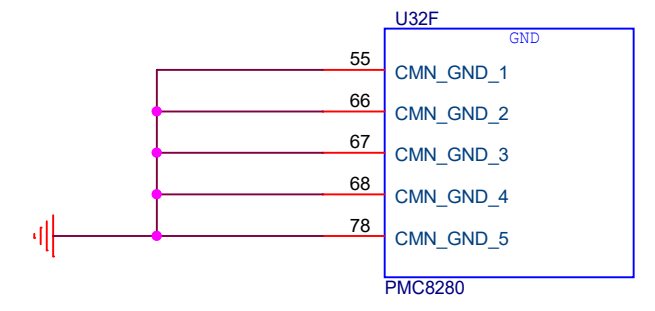
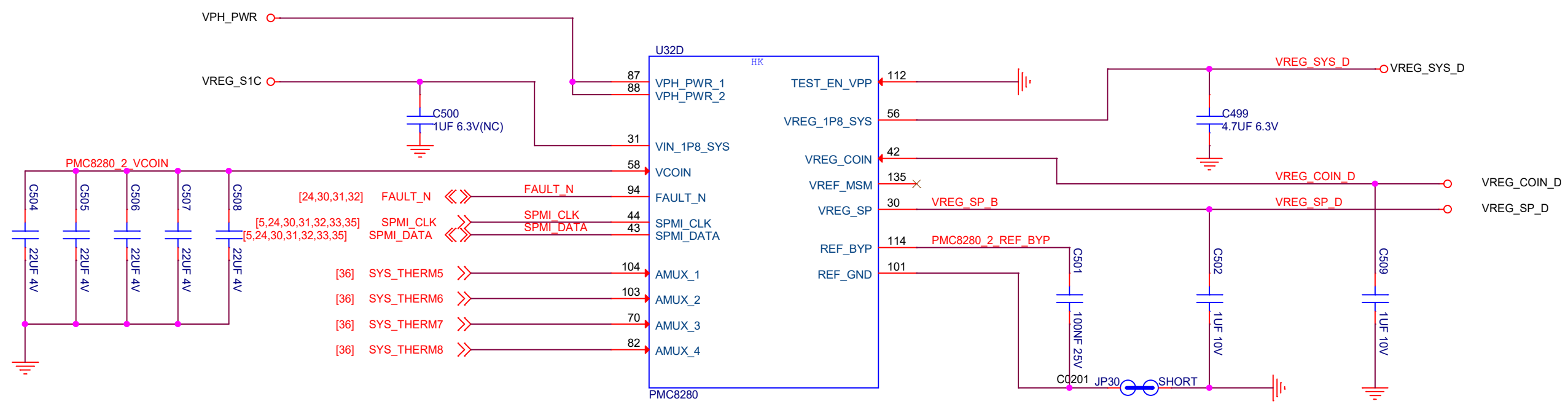
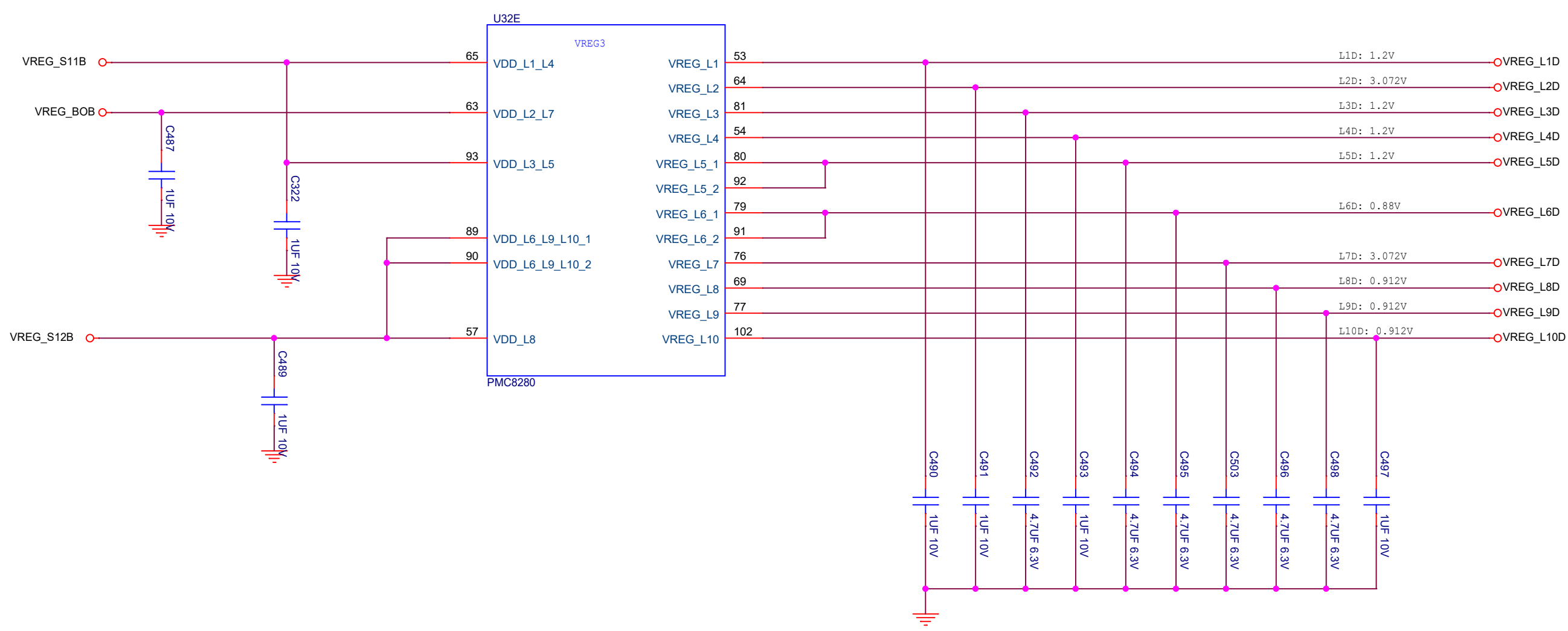

PMC8280C_BUCK_S1_S5

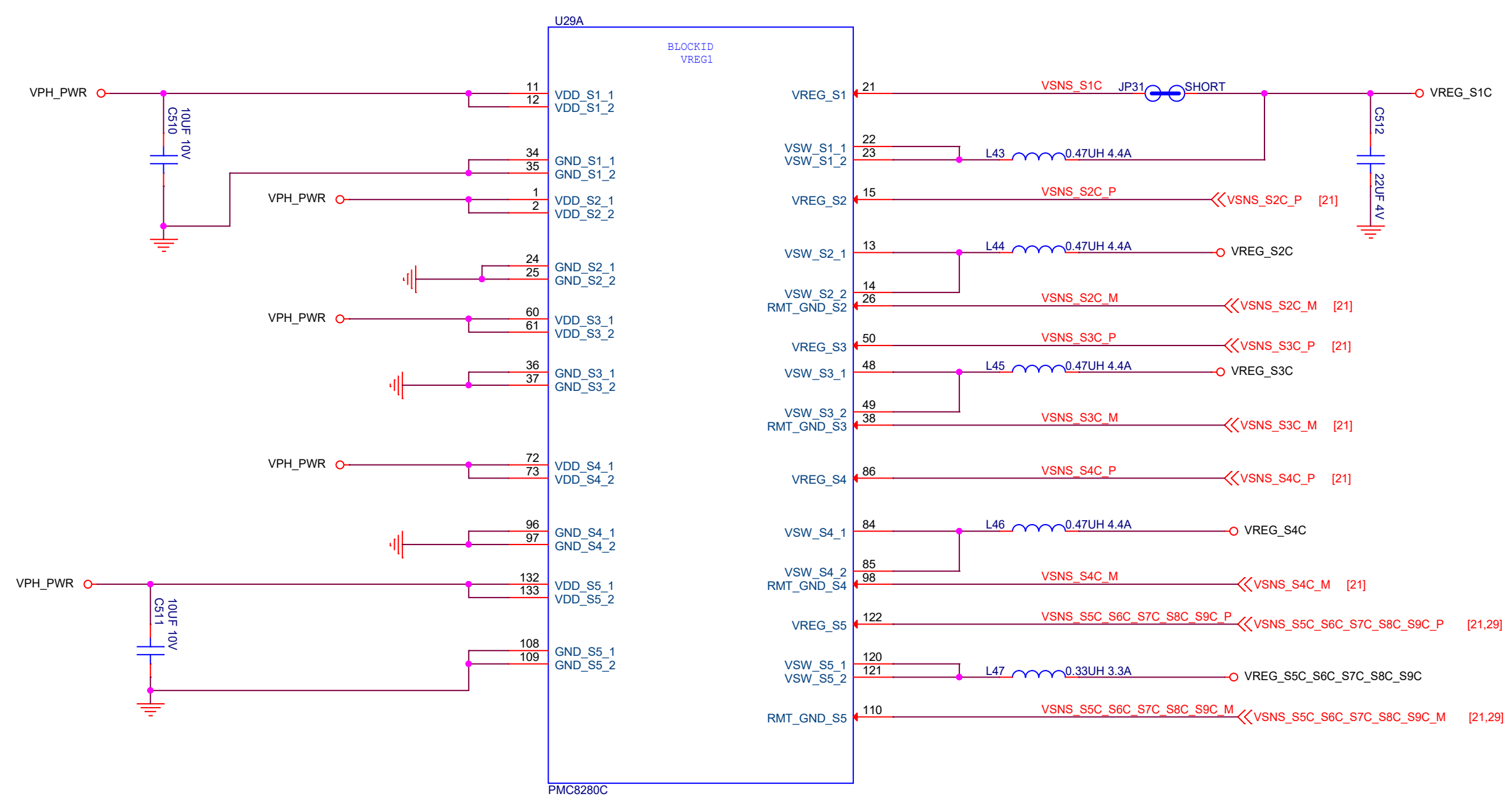

Size	Title: Radxa Dragon Q8	REV
C	Page Name: <Doc>	V1.3
Date:	Monday, June 22, 2026	Sheet 27 of 50

PMC8280C_BUCK_S6_S10

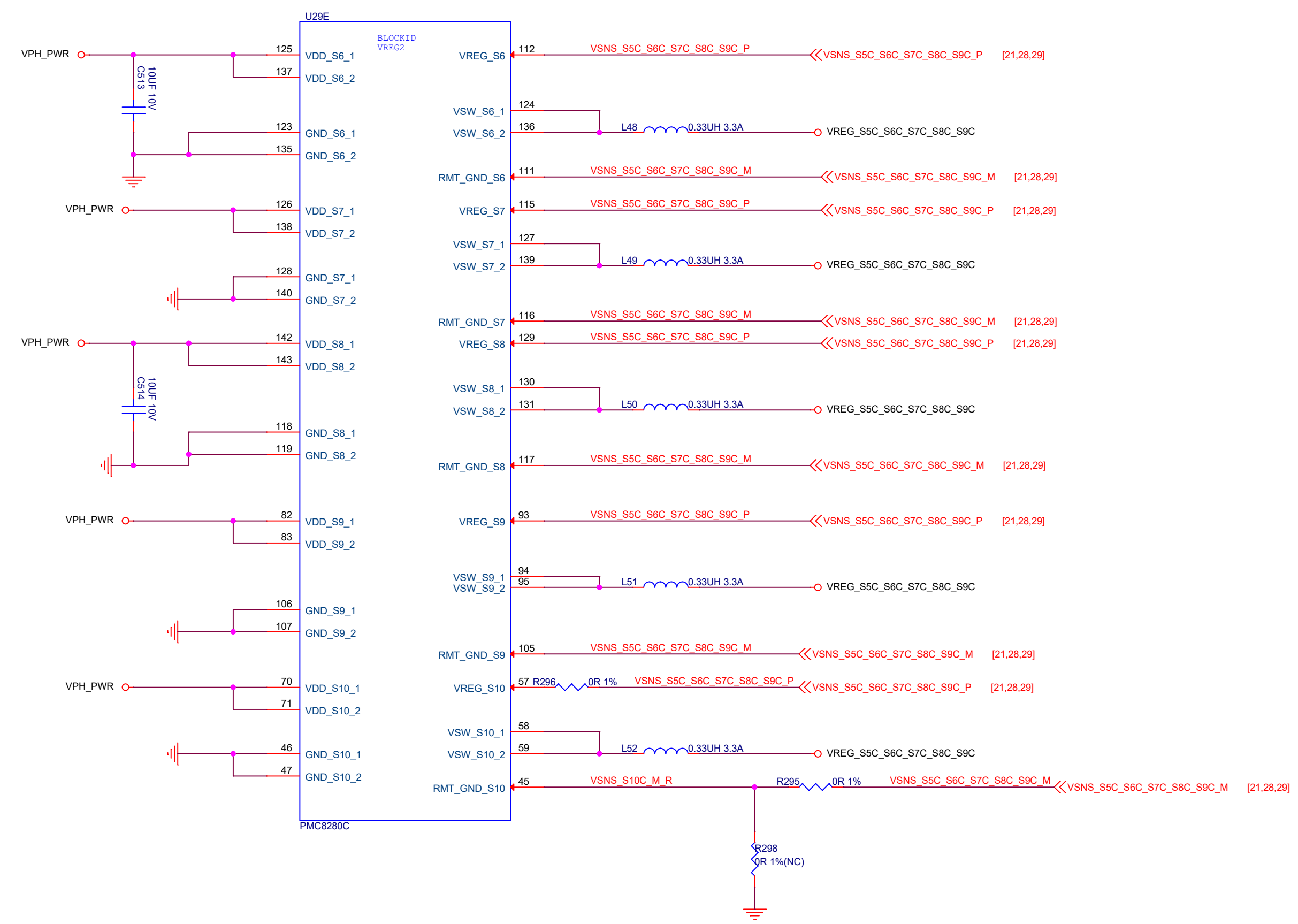

Size	Title: Radxa Dragon Q8	REV
C	Page Name: <Doc>	V1.3
Date: Monday, June 22, 2026	Sheet 28 of 50	

PMC8280C_BOB/FLASH/HK

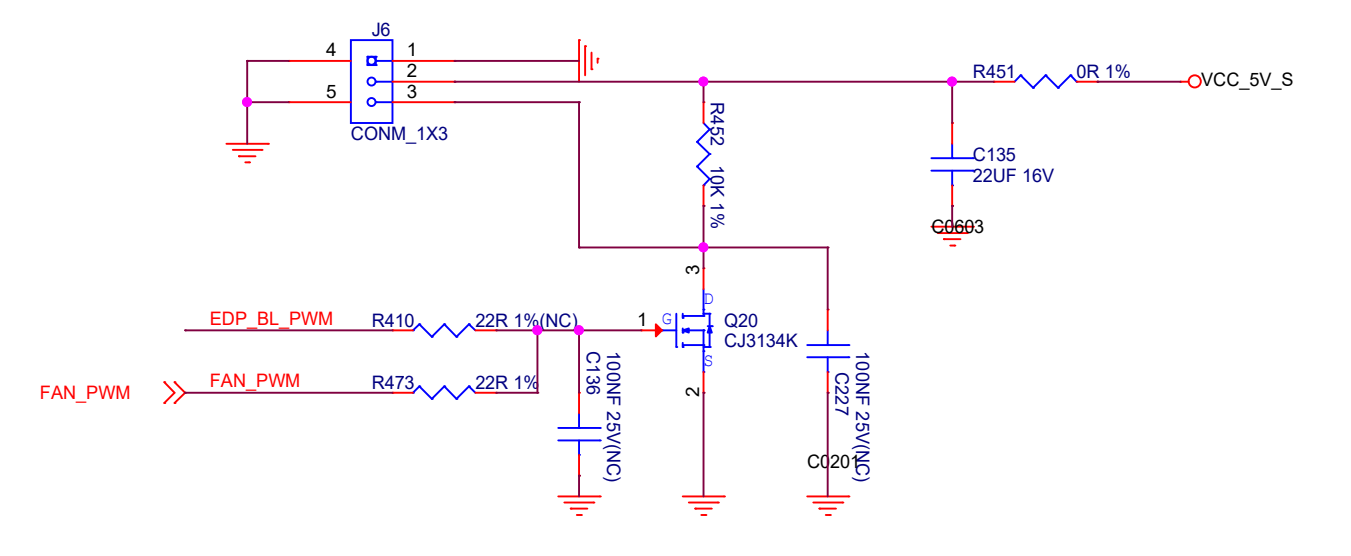
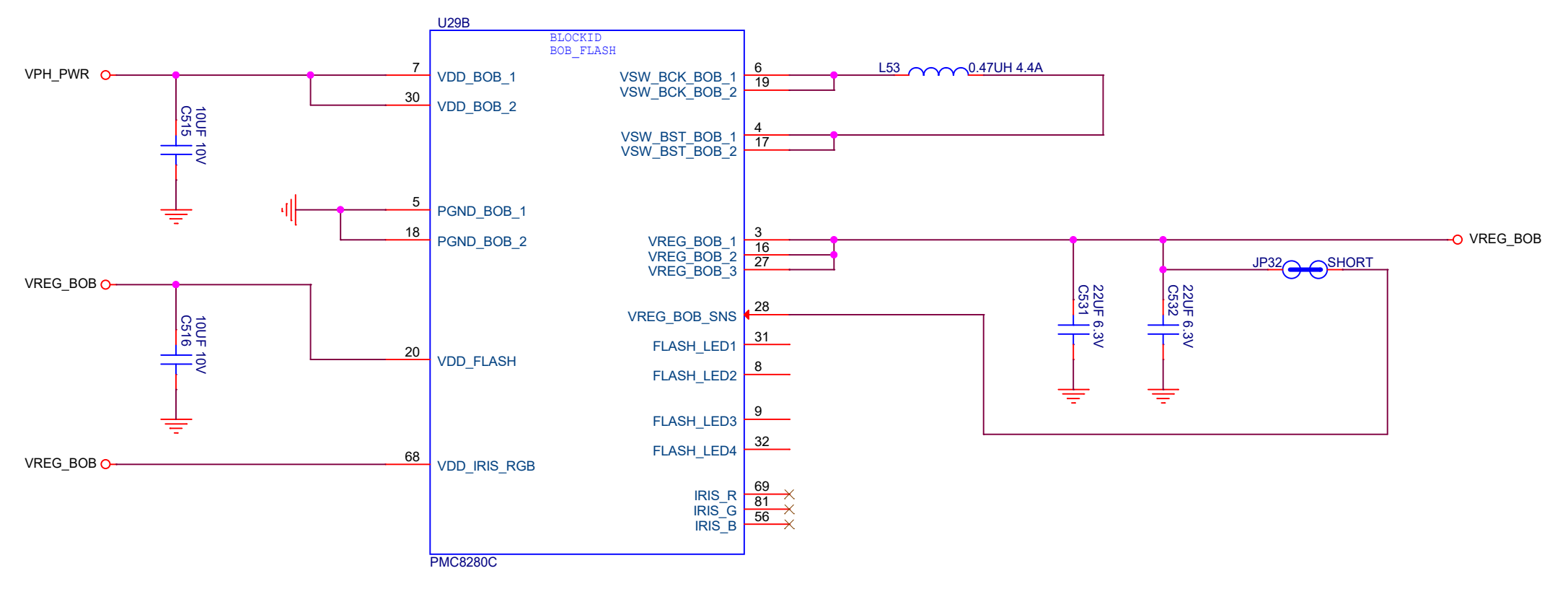
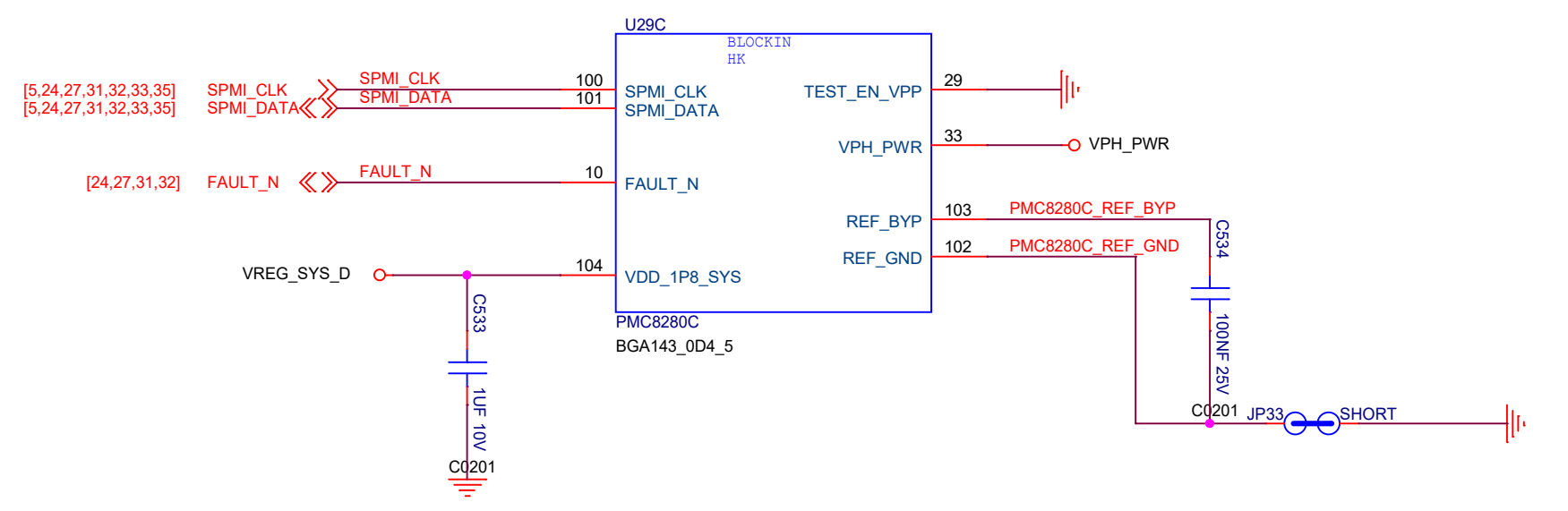
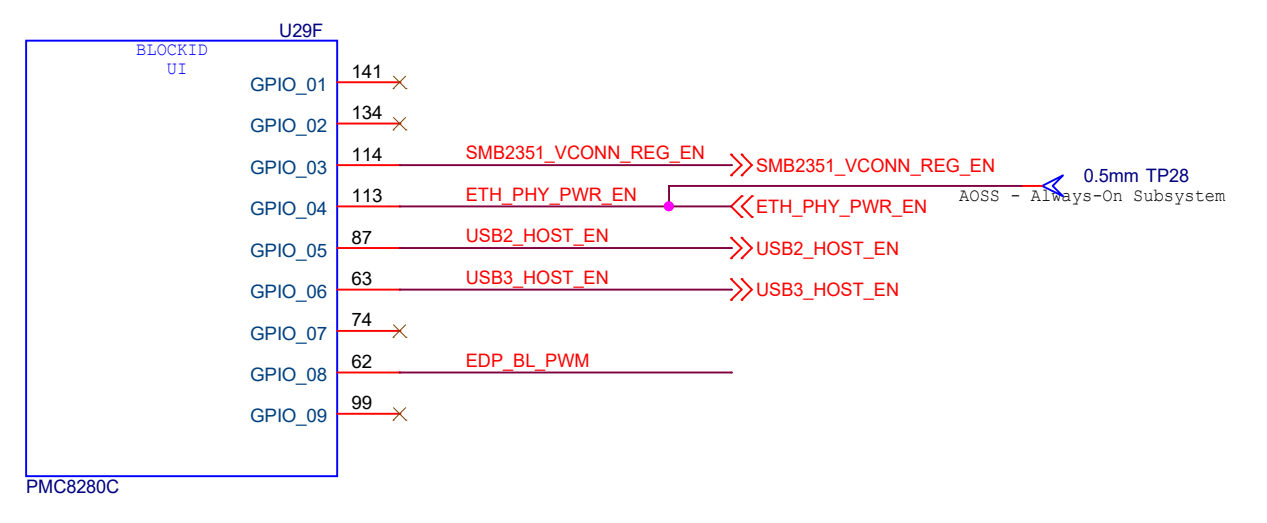
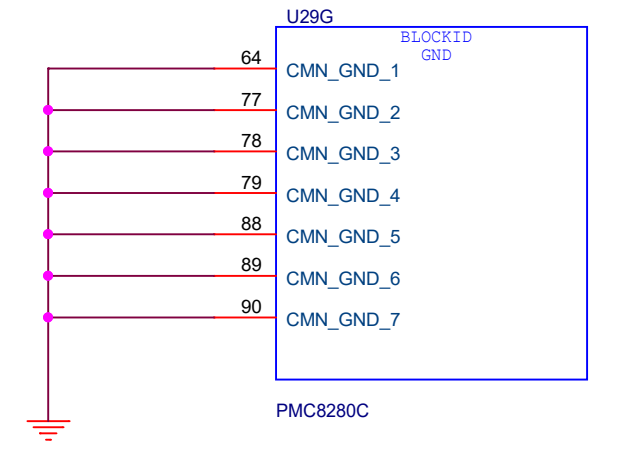
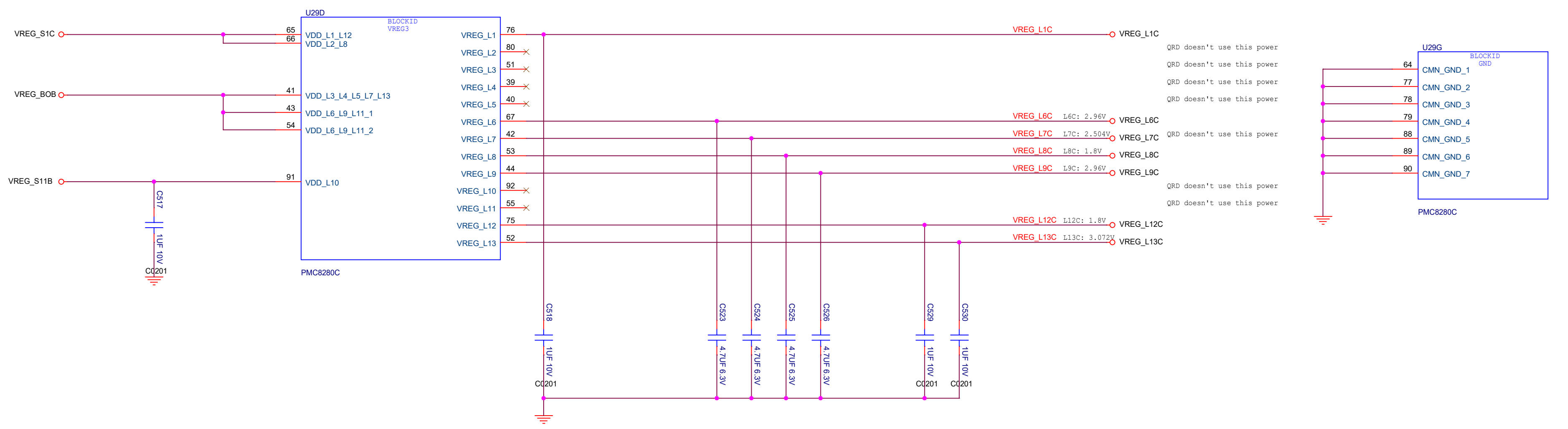

Size	Title: Radxa Dragon Q8	REV
C	Page Name: <Doc>	V1.3
Date: Monday, June 22, 2026	Sheet 29 of 50	

PMR735A

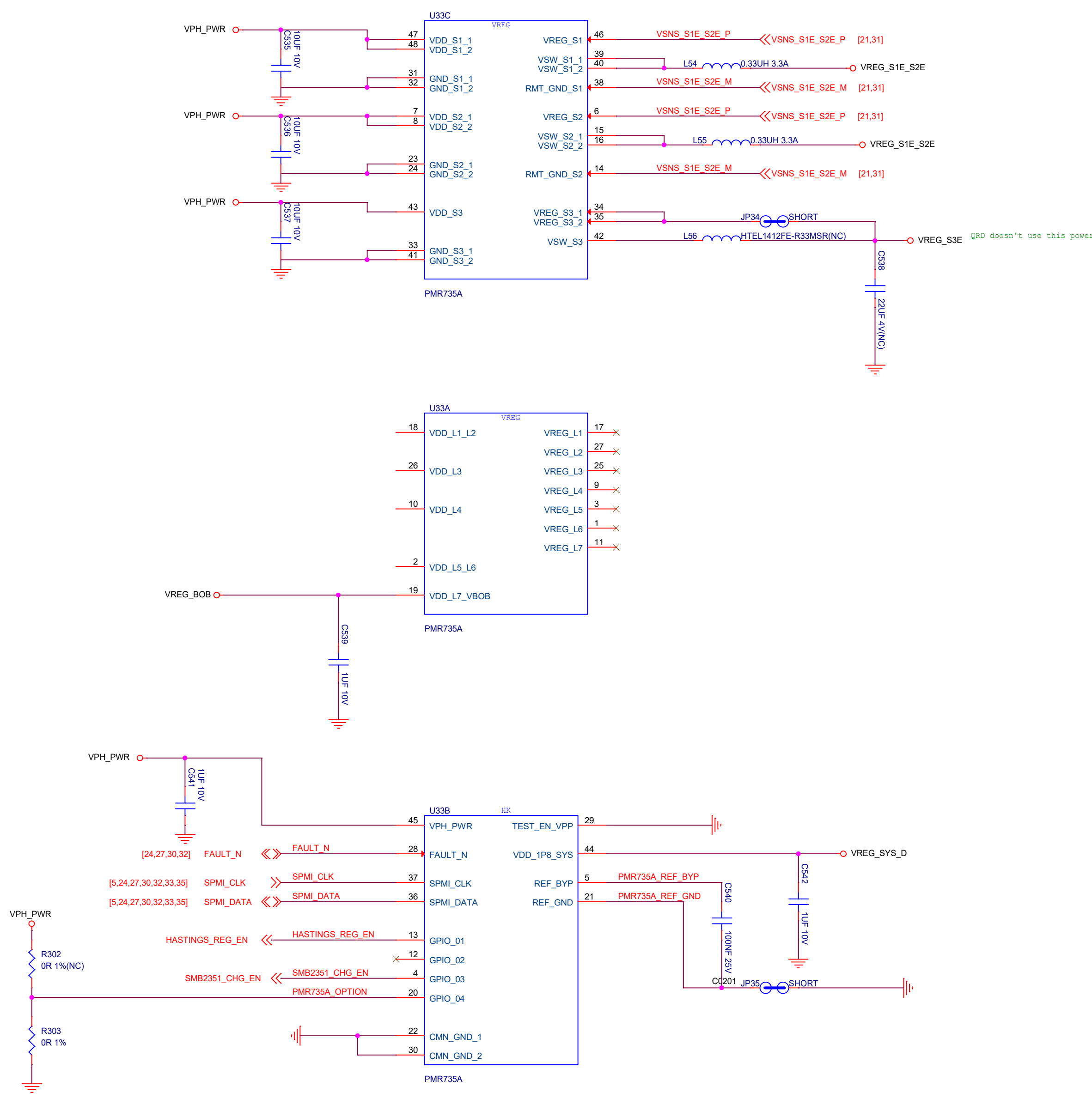

Size	Title: Radxa Dragon Q8	REV
C	Page Name: <Doc>	V1.3
Date:	Monday, June 22, 2026	Sheet 30 of 50

PMK8280

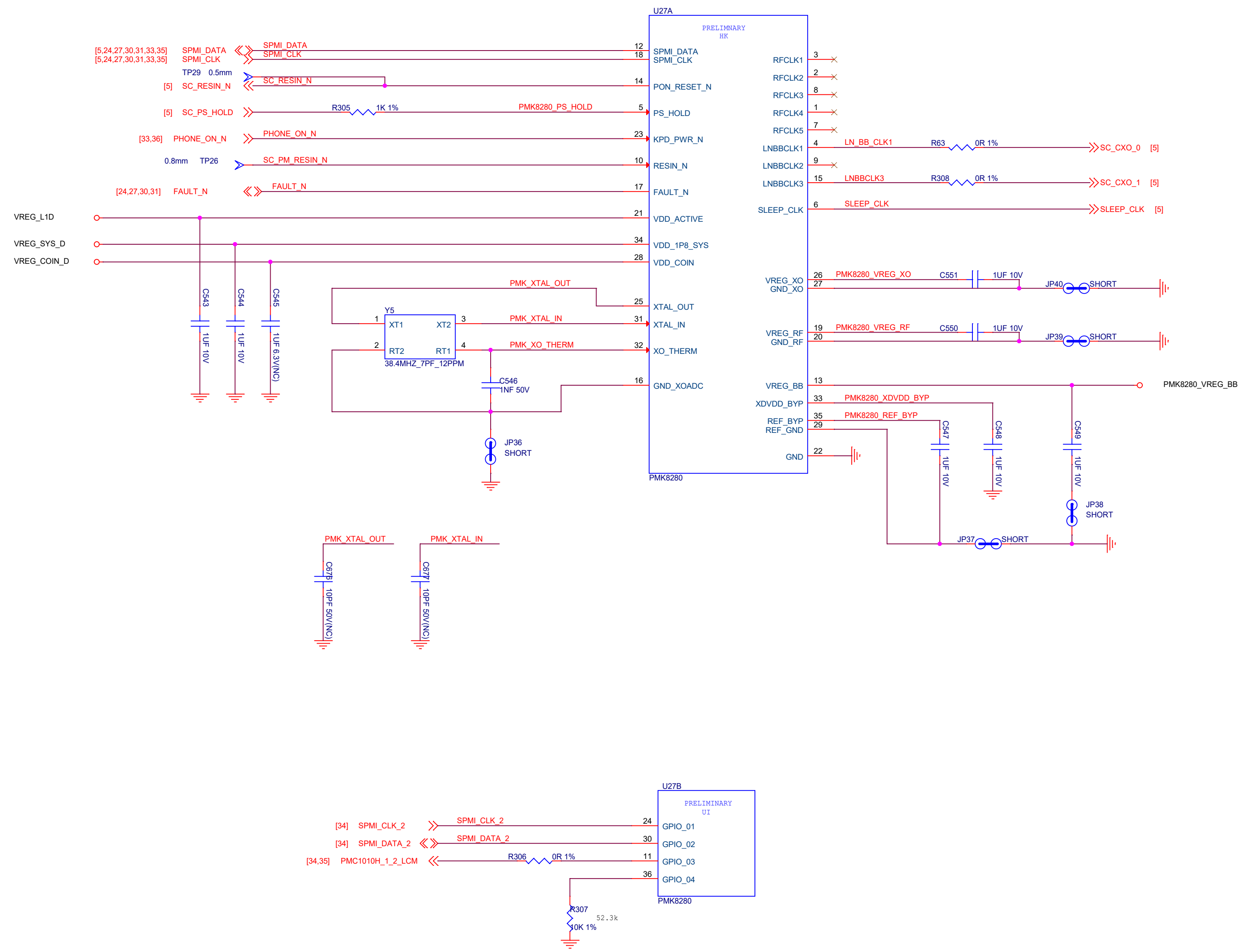

Size	Title: Radxa Dragon Q8	REV
C	Page Name: <Doc>	V1.3
Date:	Monday, June 22, 2026	Sheet 31 of 50

SMB2351_1_2

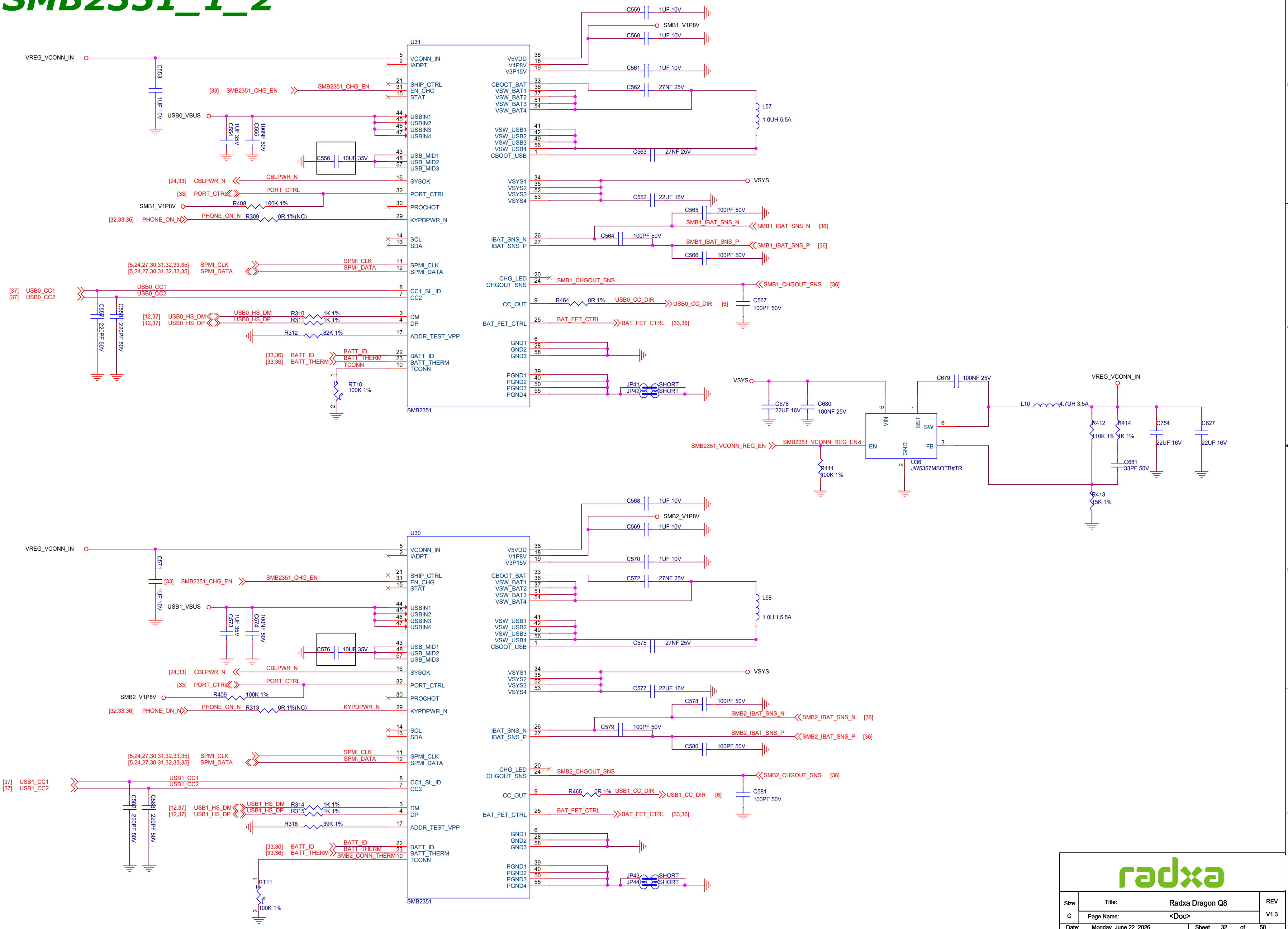

PMC1010H_1

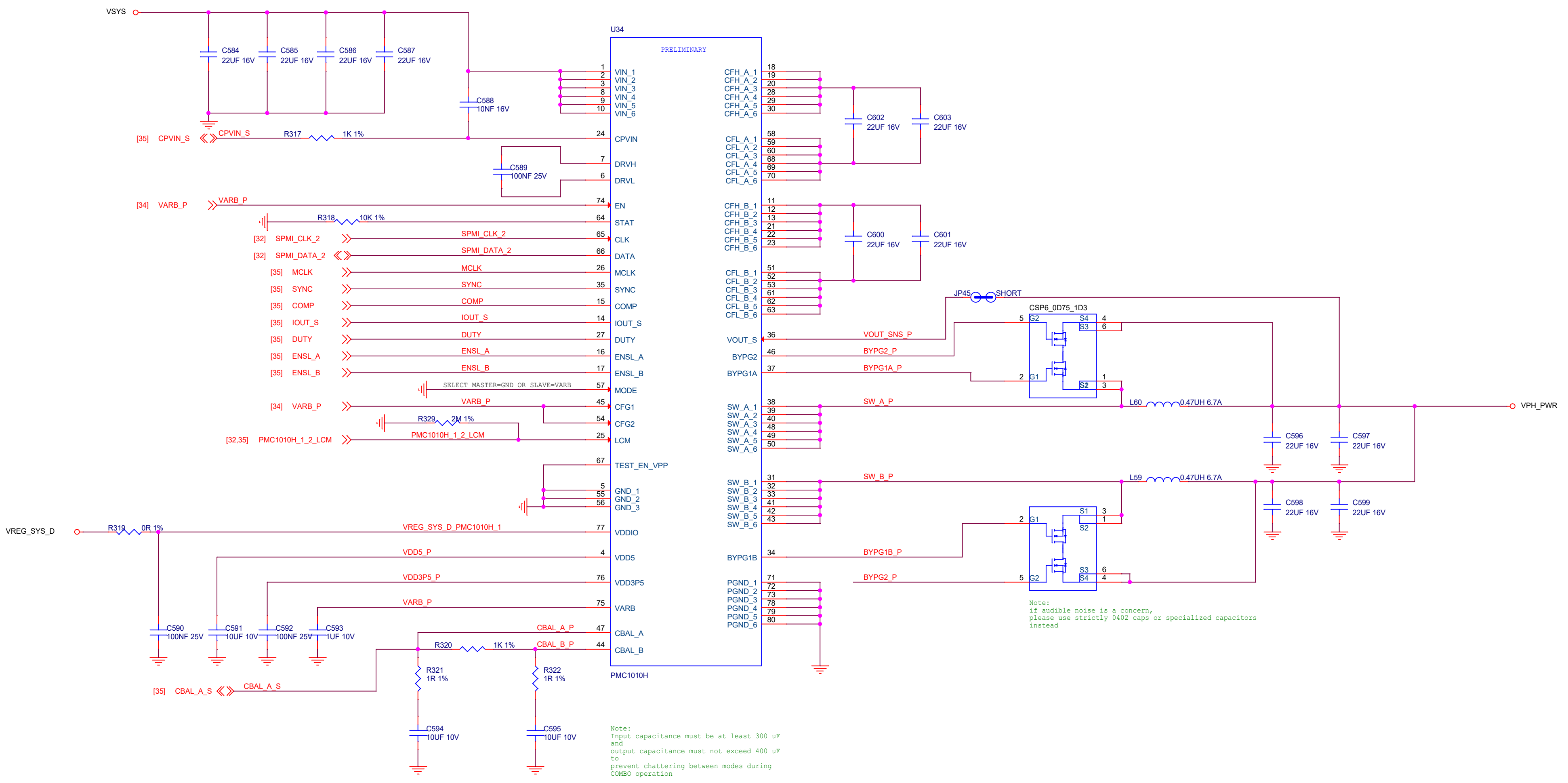

PMC1010H_2

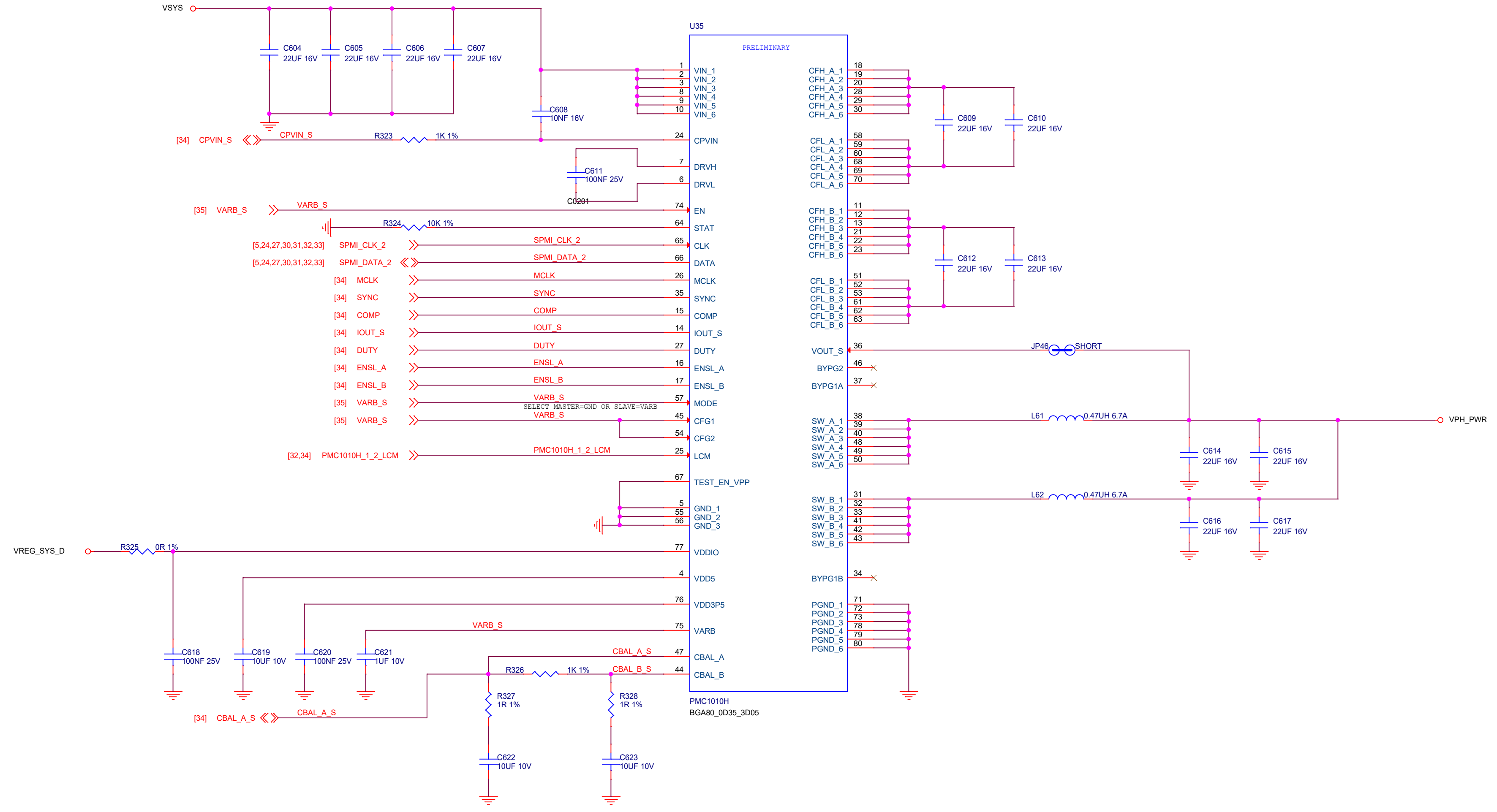

Size	Title: Radxa Dragon Q8	REV
C	Page Name: <Doc>	V1.3
Date:	Monday, June 22, 2026	Sheet 34 of 50

BAT_SEN

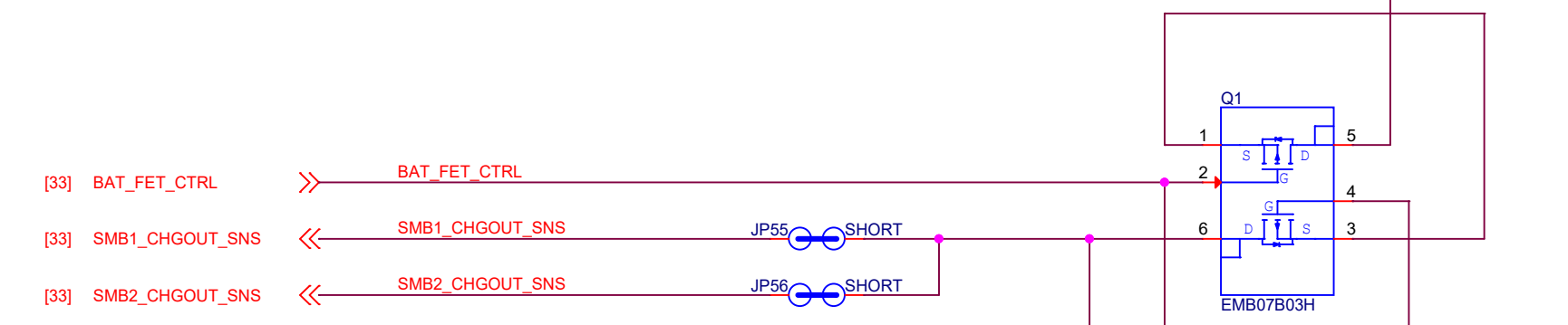
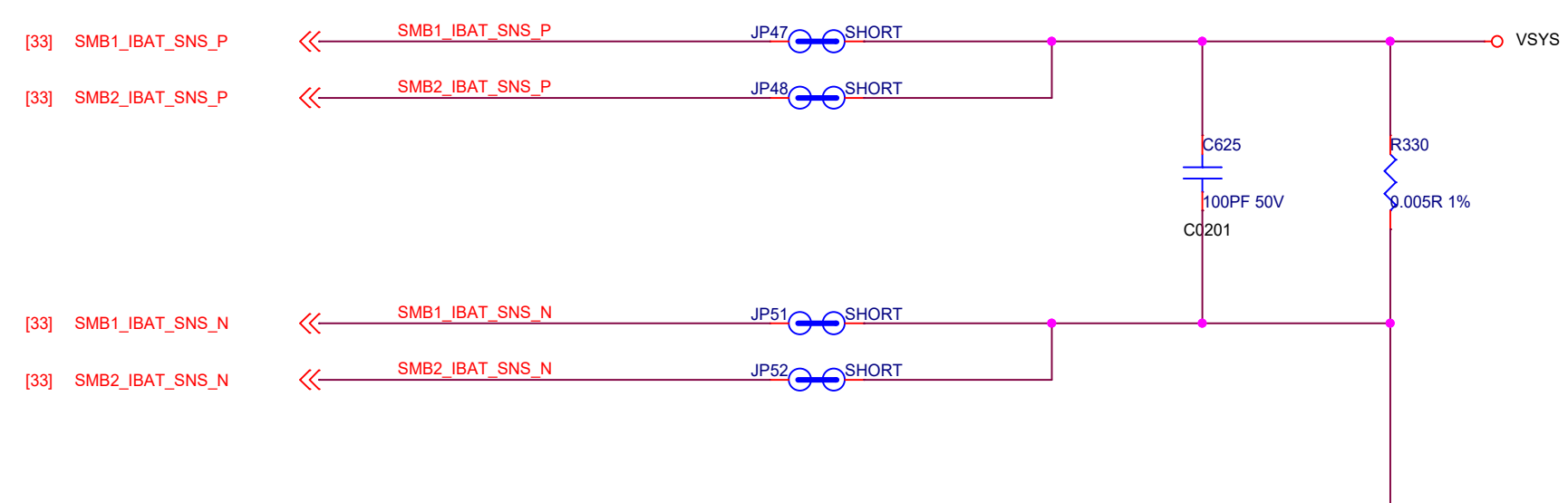

BATT THERM:
 --100 kΩ pull-down to GND
 (to fake good battery temperature)

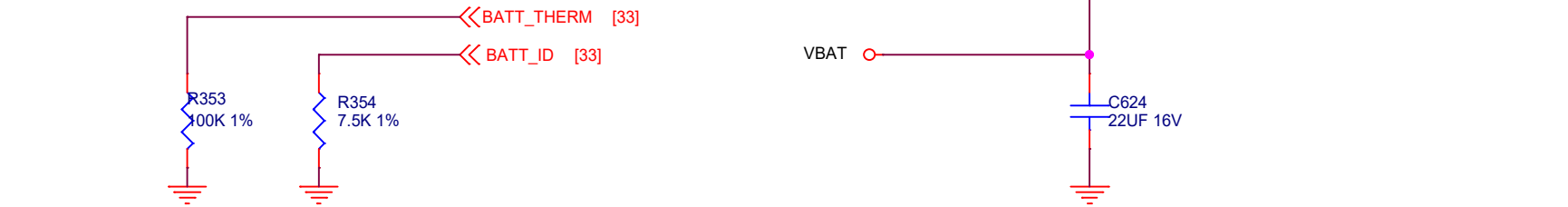

BATT ID:
 When "Fake Battery" detection is enabled, a nominal resistance of 7.5 k to PGND applied to the BAT_ID pin indicates that an external power supply is present instead of a Li+ cell. In this case, the user can prevent charging an external power supply. This feature is useful in a debug environment when using a real battery is difficult.

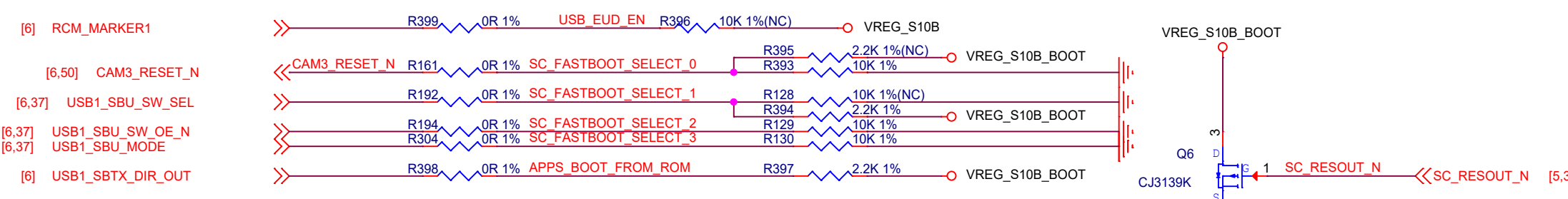
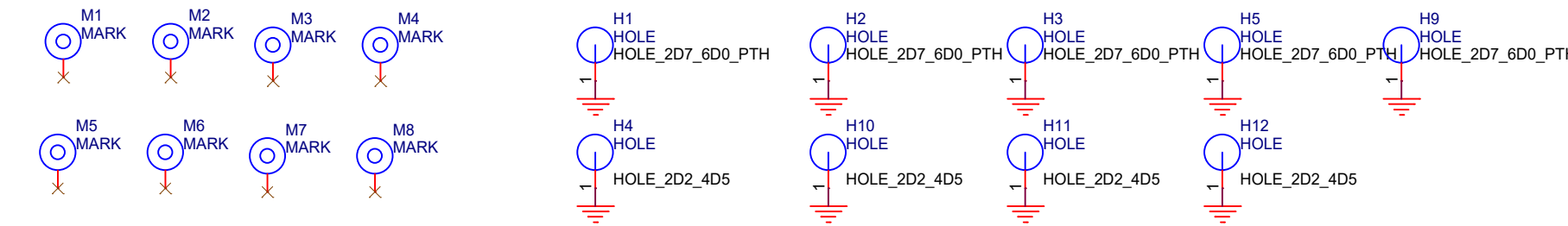
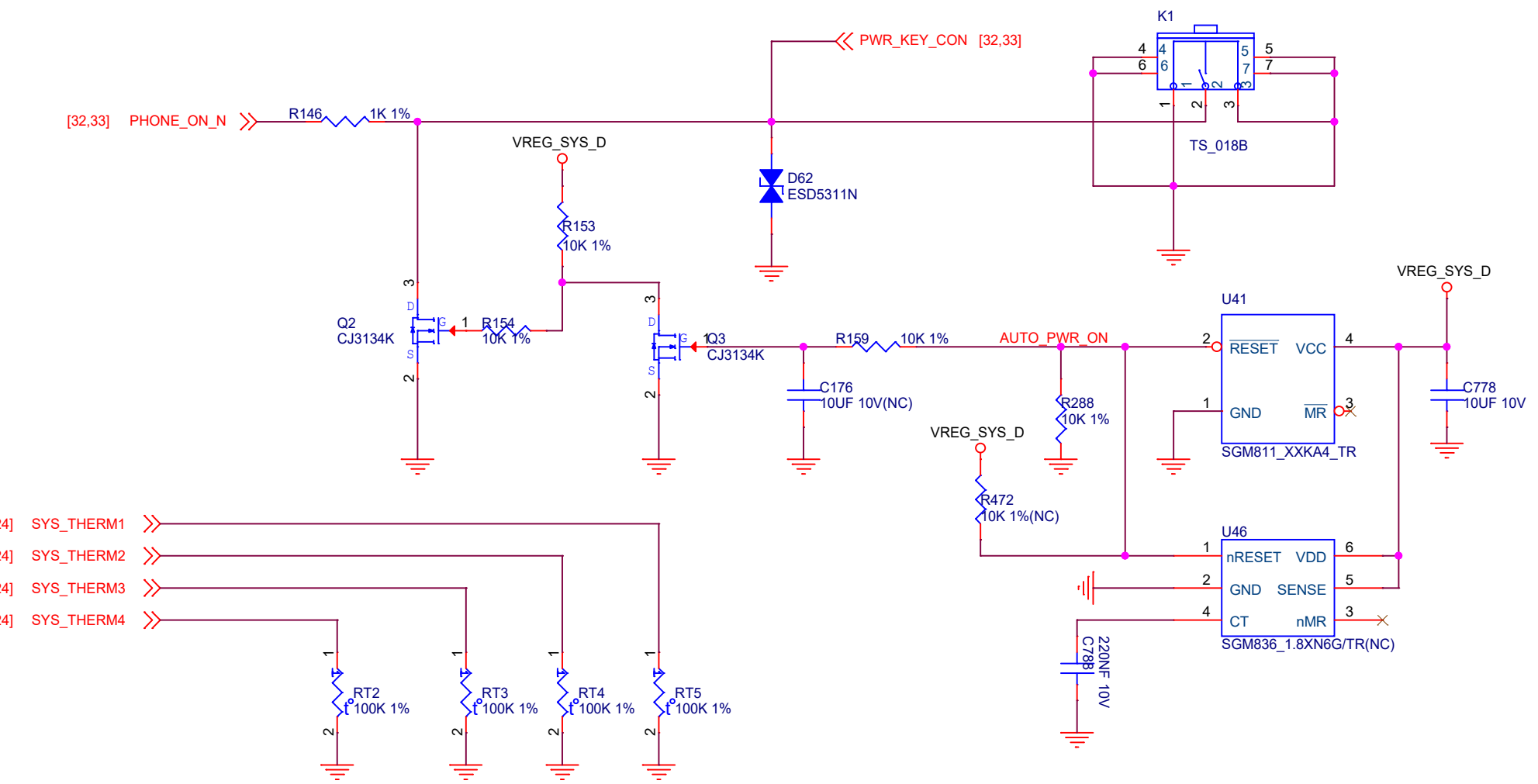
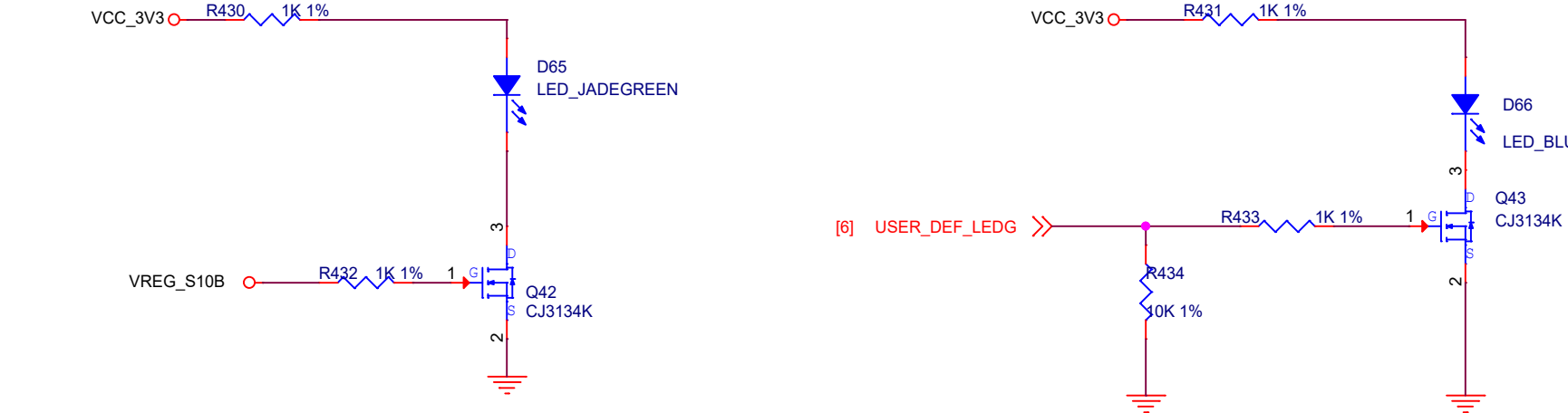

The BOOT_CONFIG GPIOs [GPIOs 50, 48, 47, 15] are used to select the boot device, when fuses are not blown.
 BOOT_CONFIG[4:1]
 0b0000 - Default : UFS0 -> eDL(USB0)
 0b0001 - SDC2 -> eDL(USB0)
 0b0010 - QSPI -> eDL(USB0)
 0b0011 - SPI -> eDL(USB0)
 0b0100 - UFS0 -> eDL(USB0)
 0b0101 - USB only

The boot configuration function of this GPIO is only active at the time of boot, before RESOUT_N is deasserted.

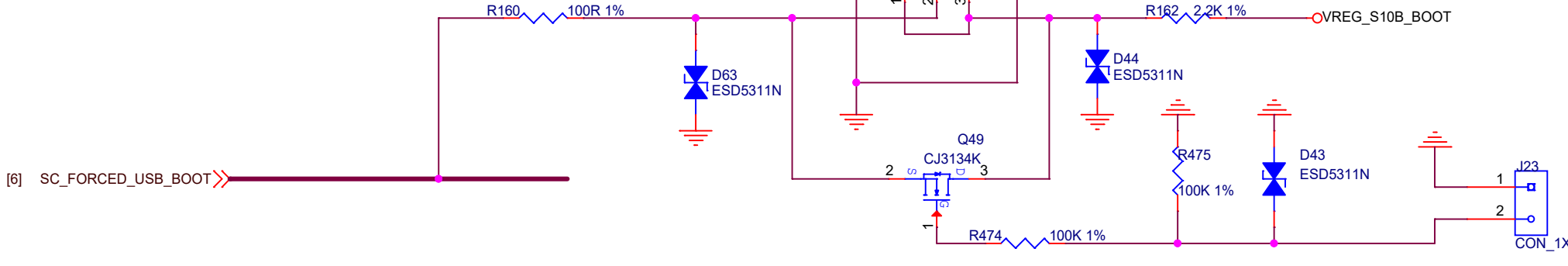

QSPI FLASH FOR BOOT

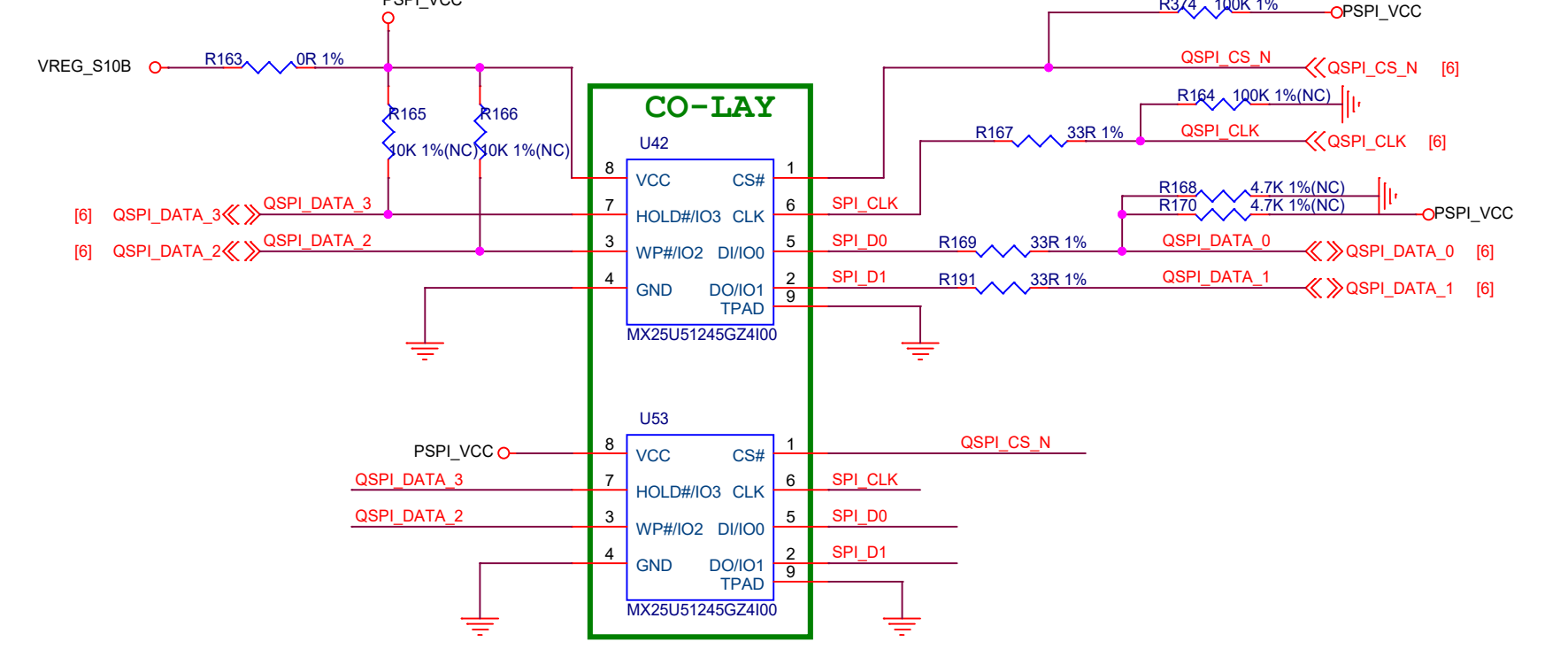

TPM

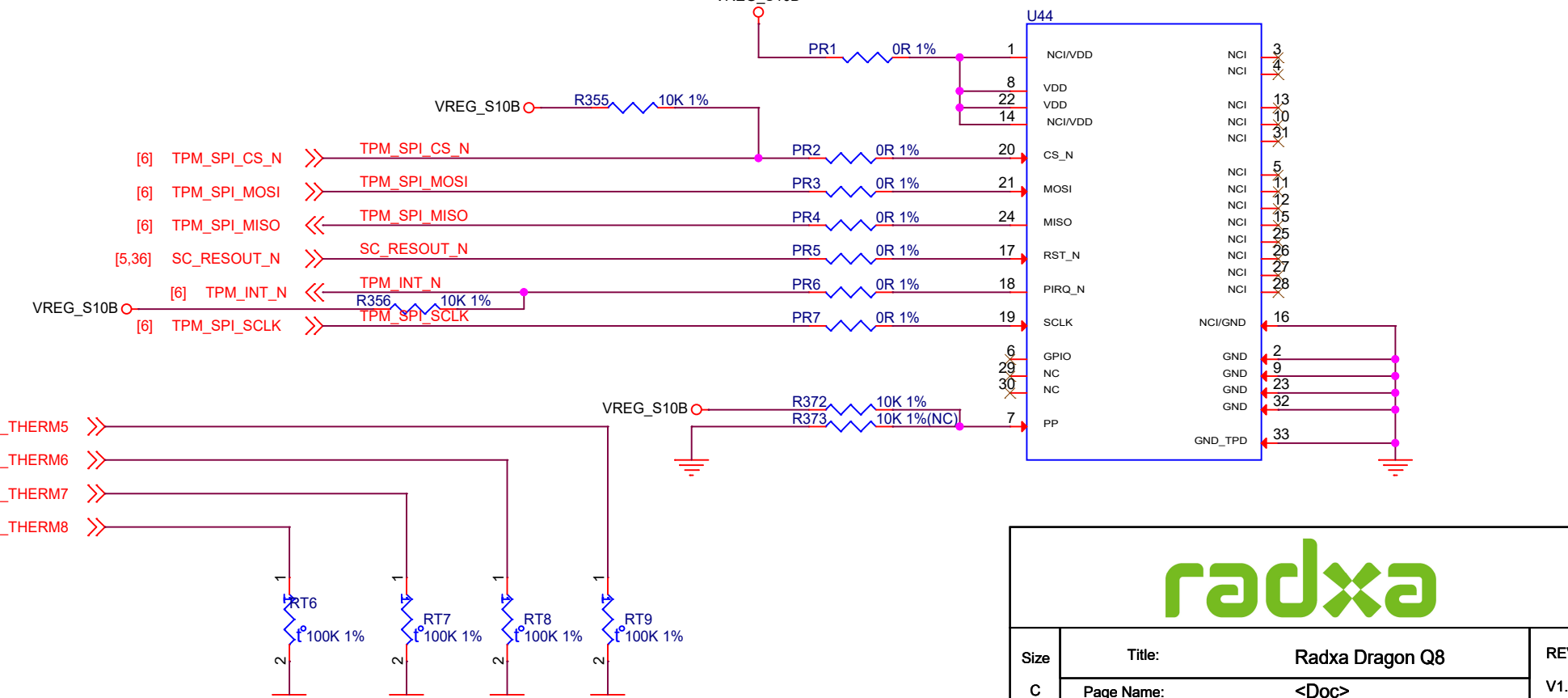

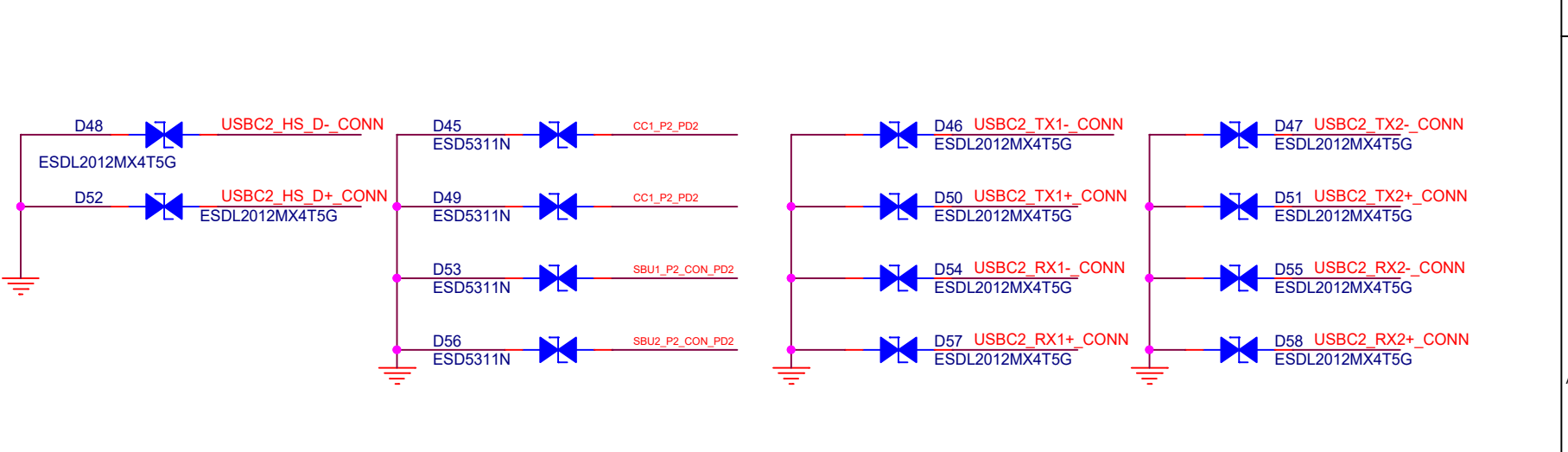
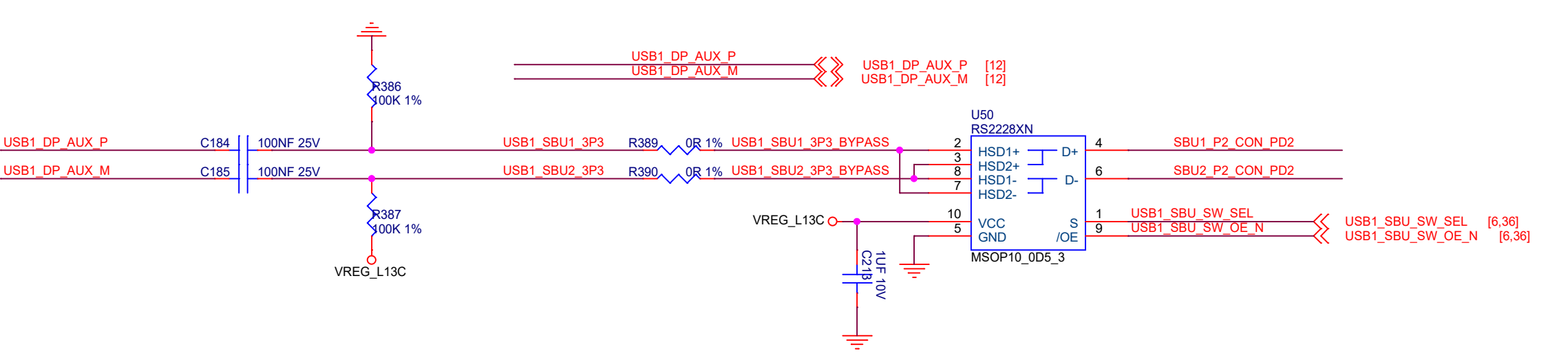
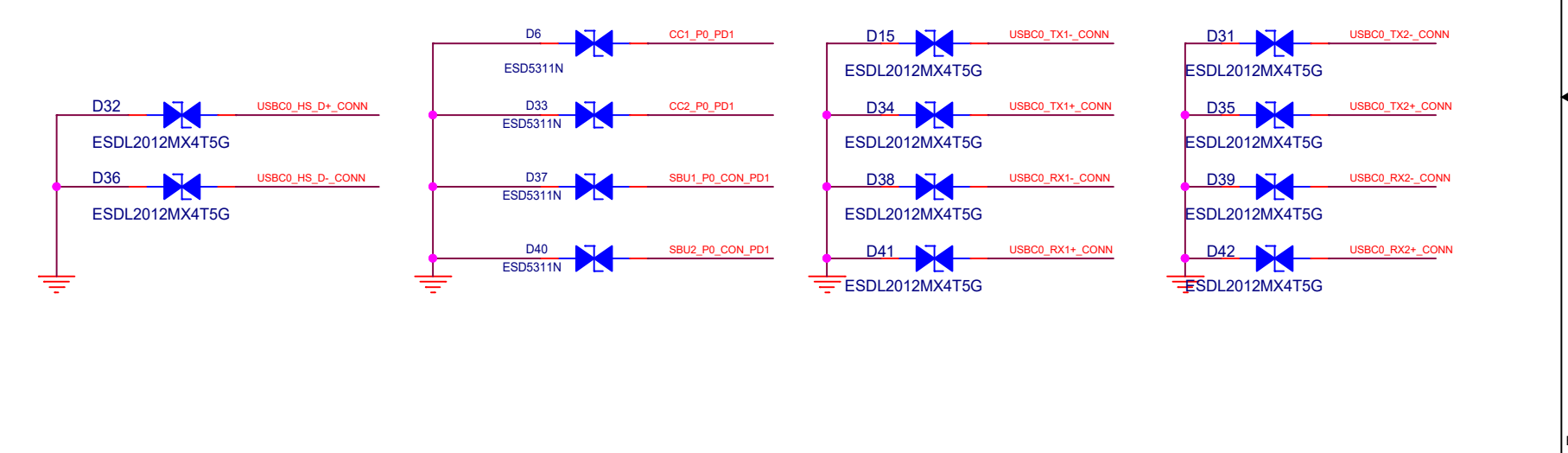
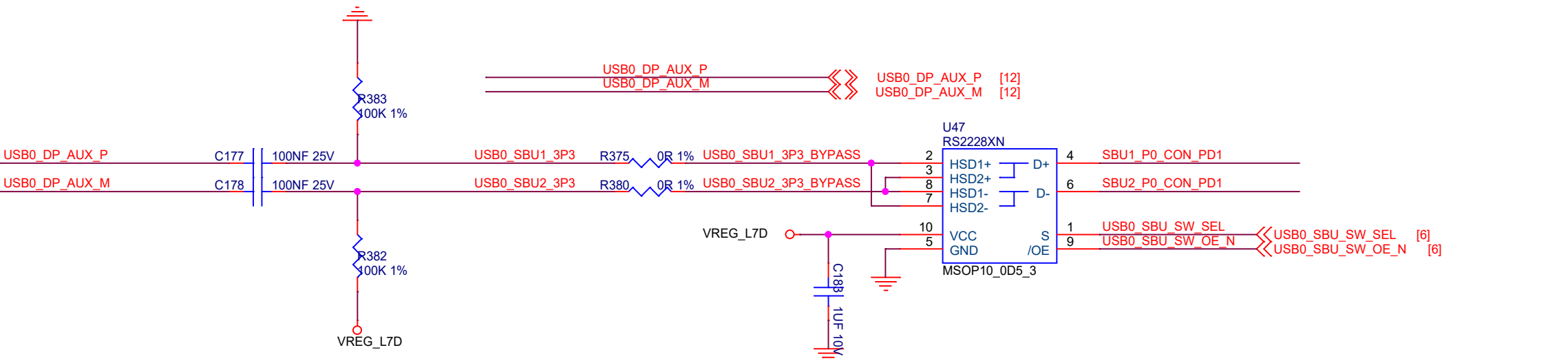
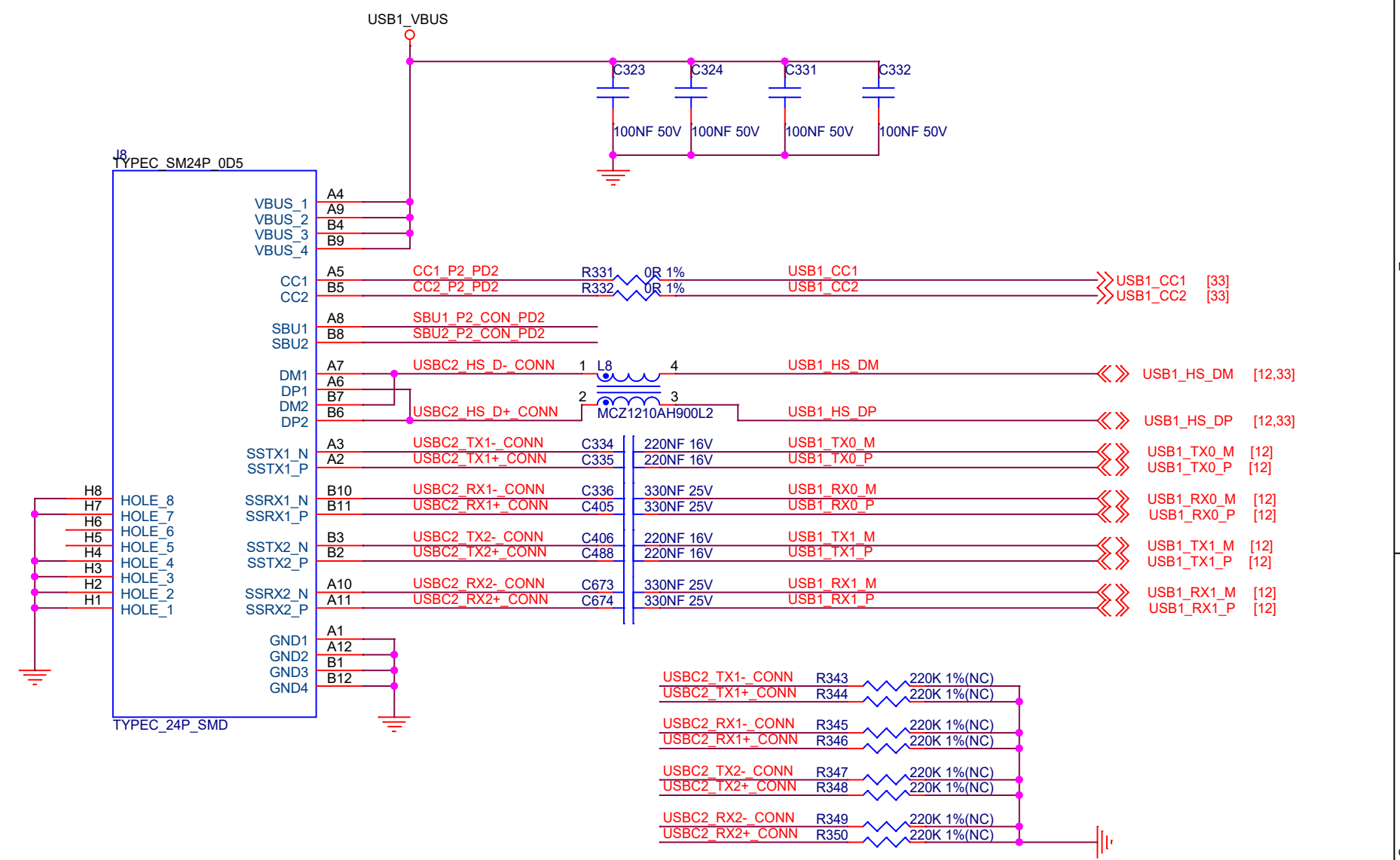
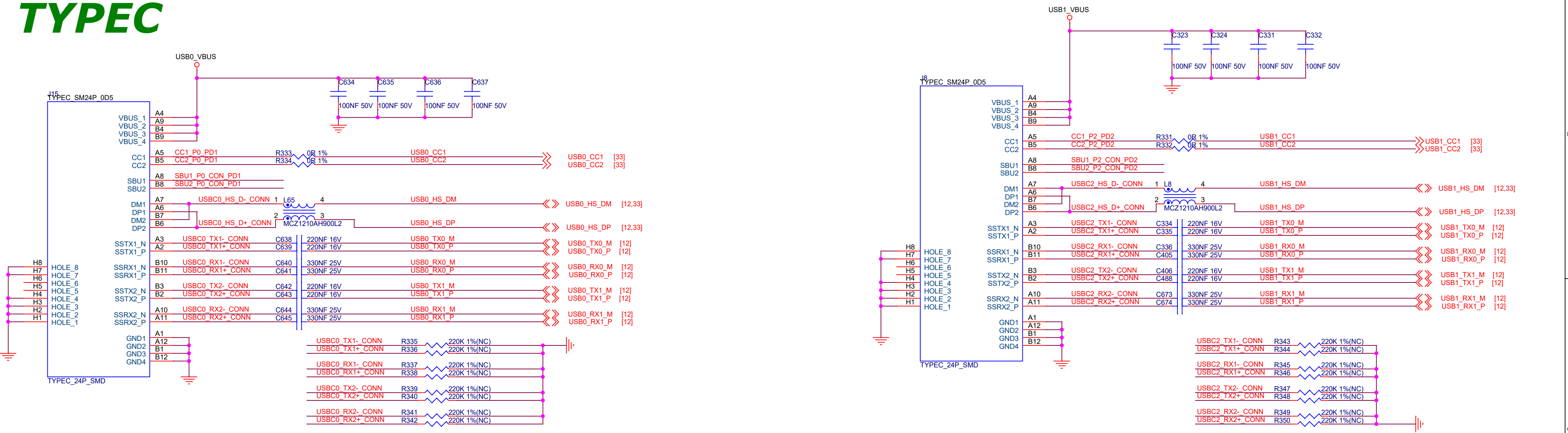

40PIN

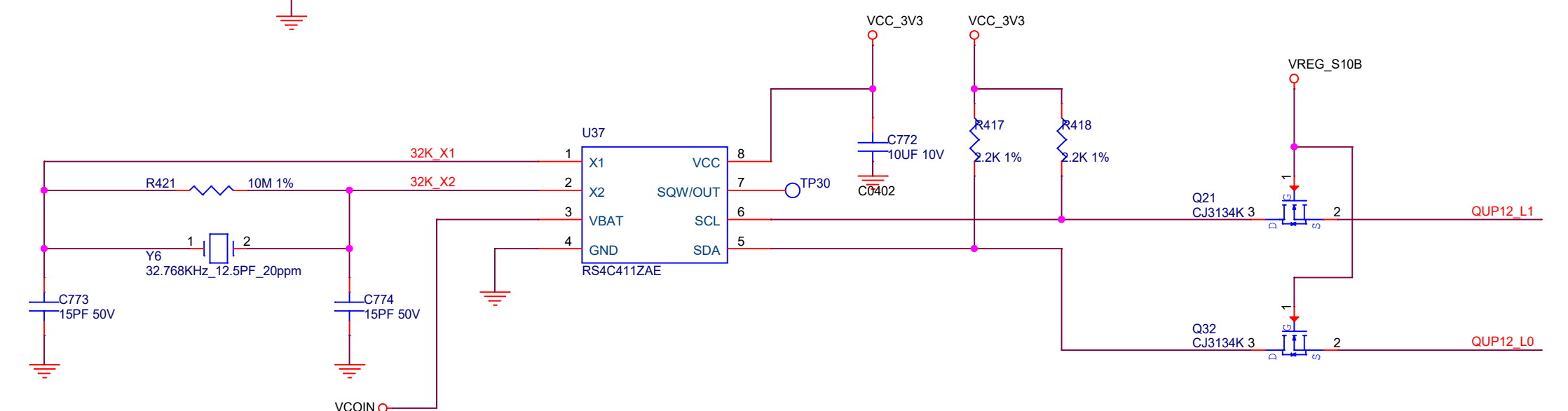
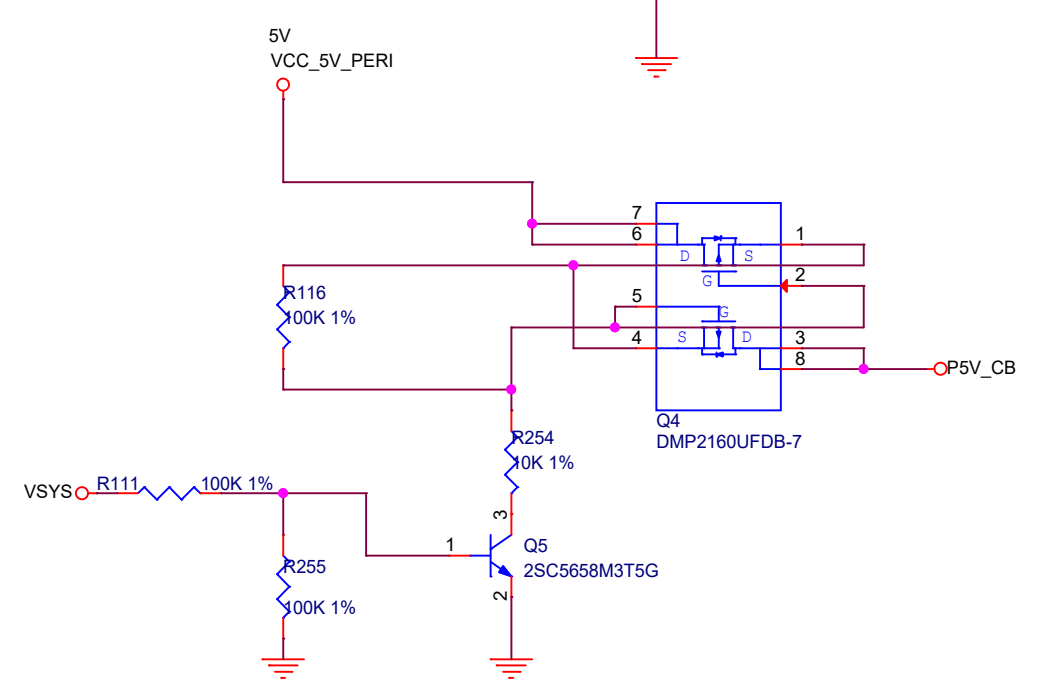
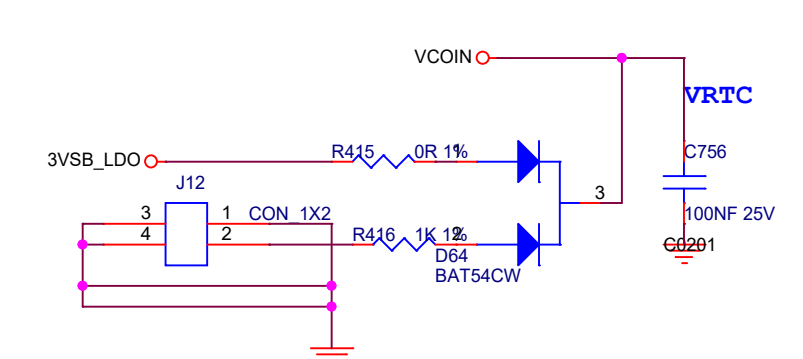
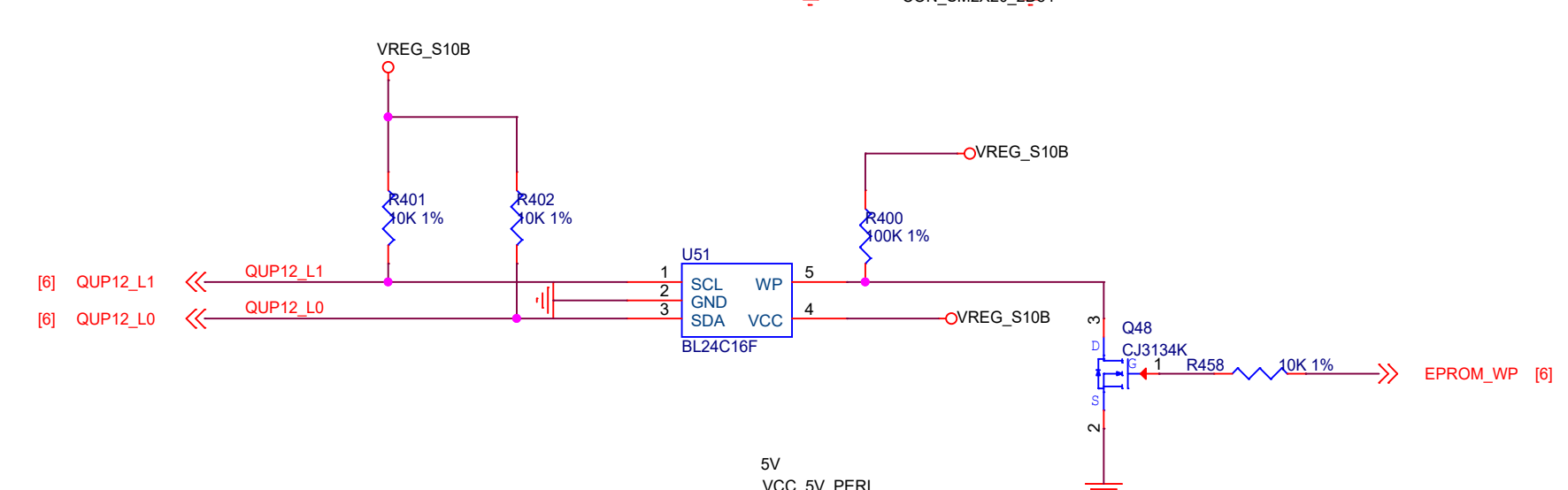
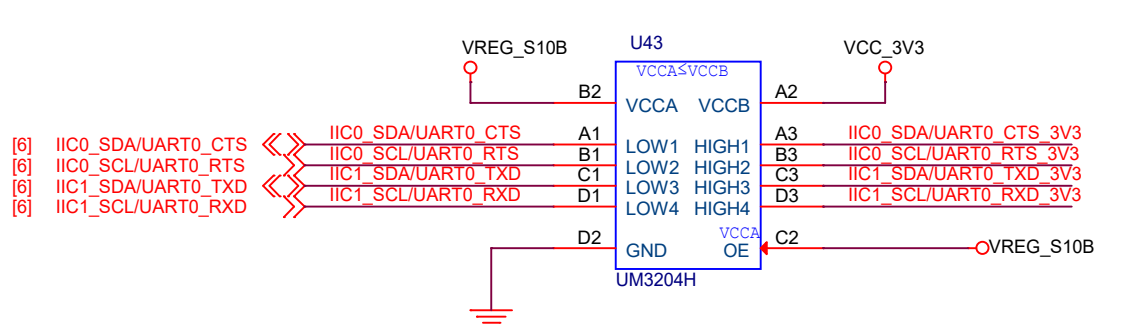
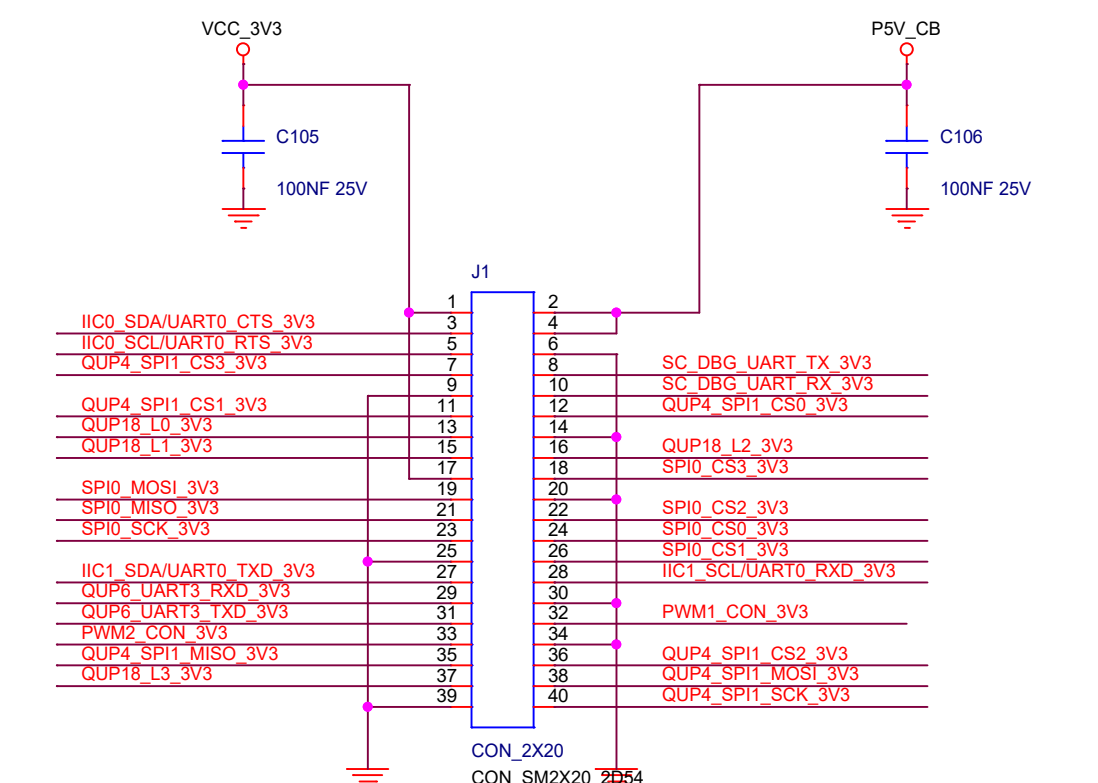
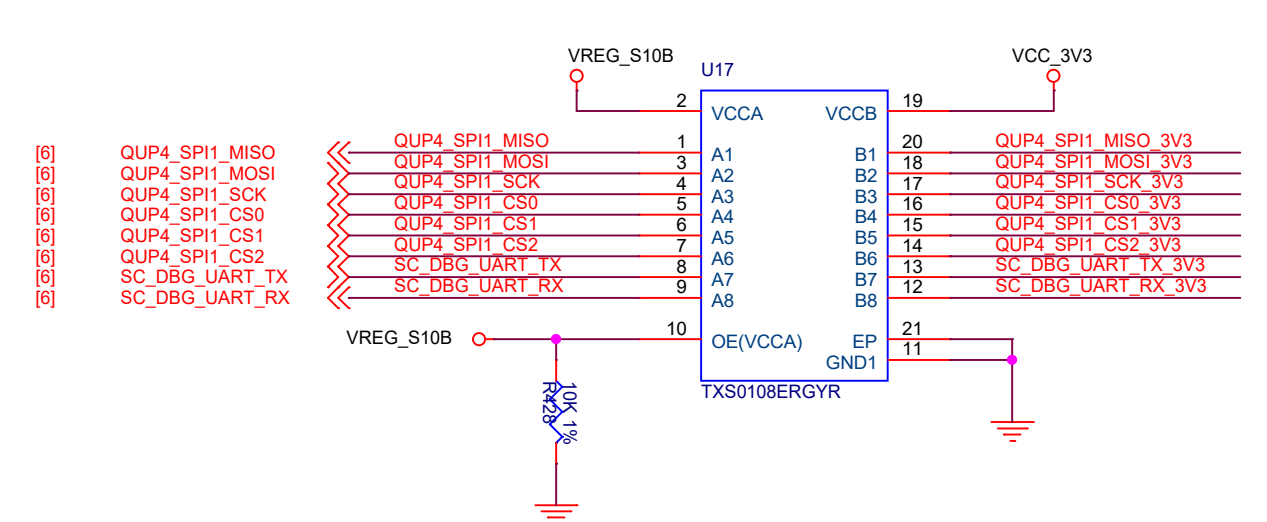
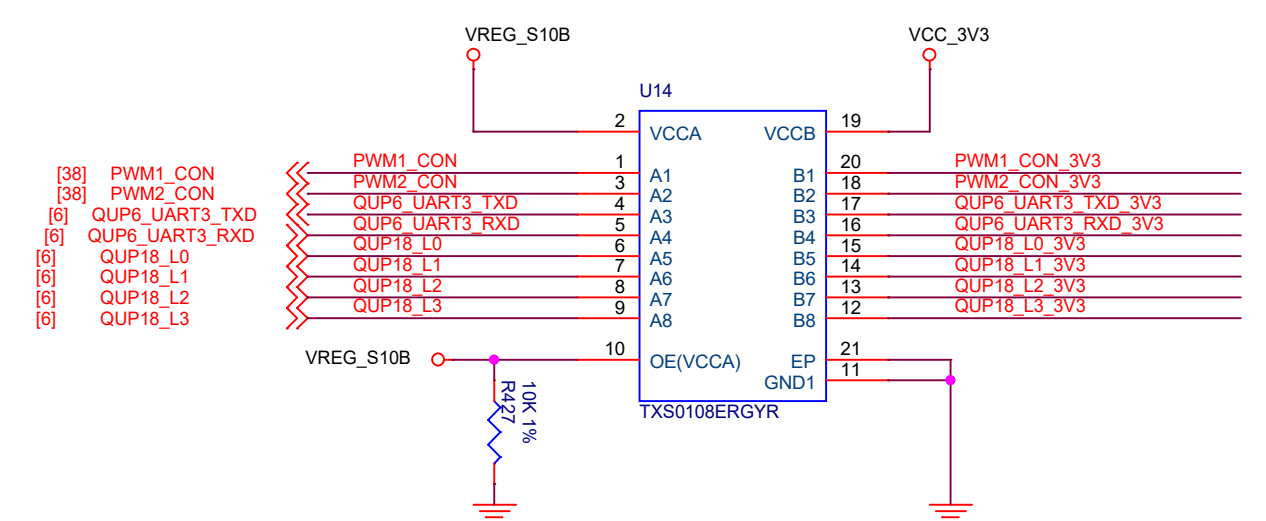
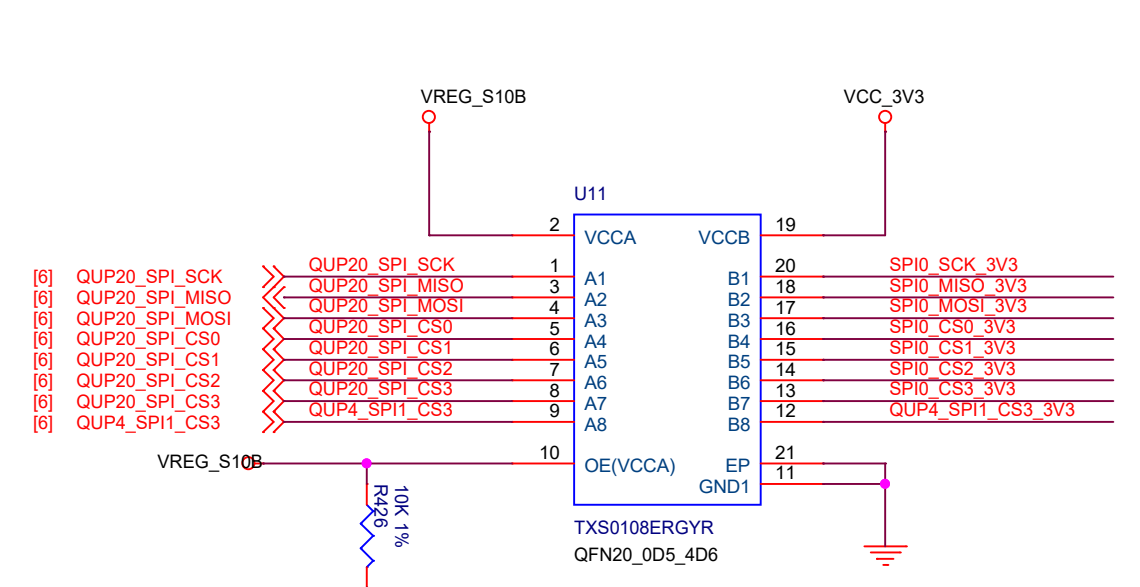

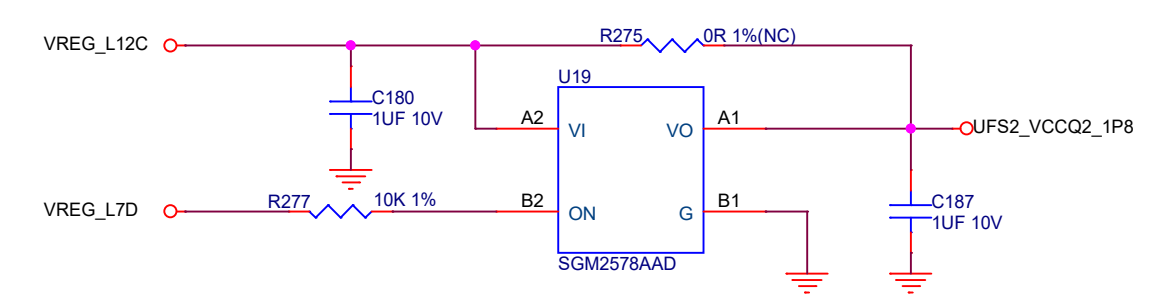
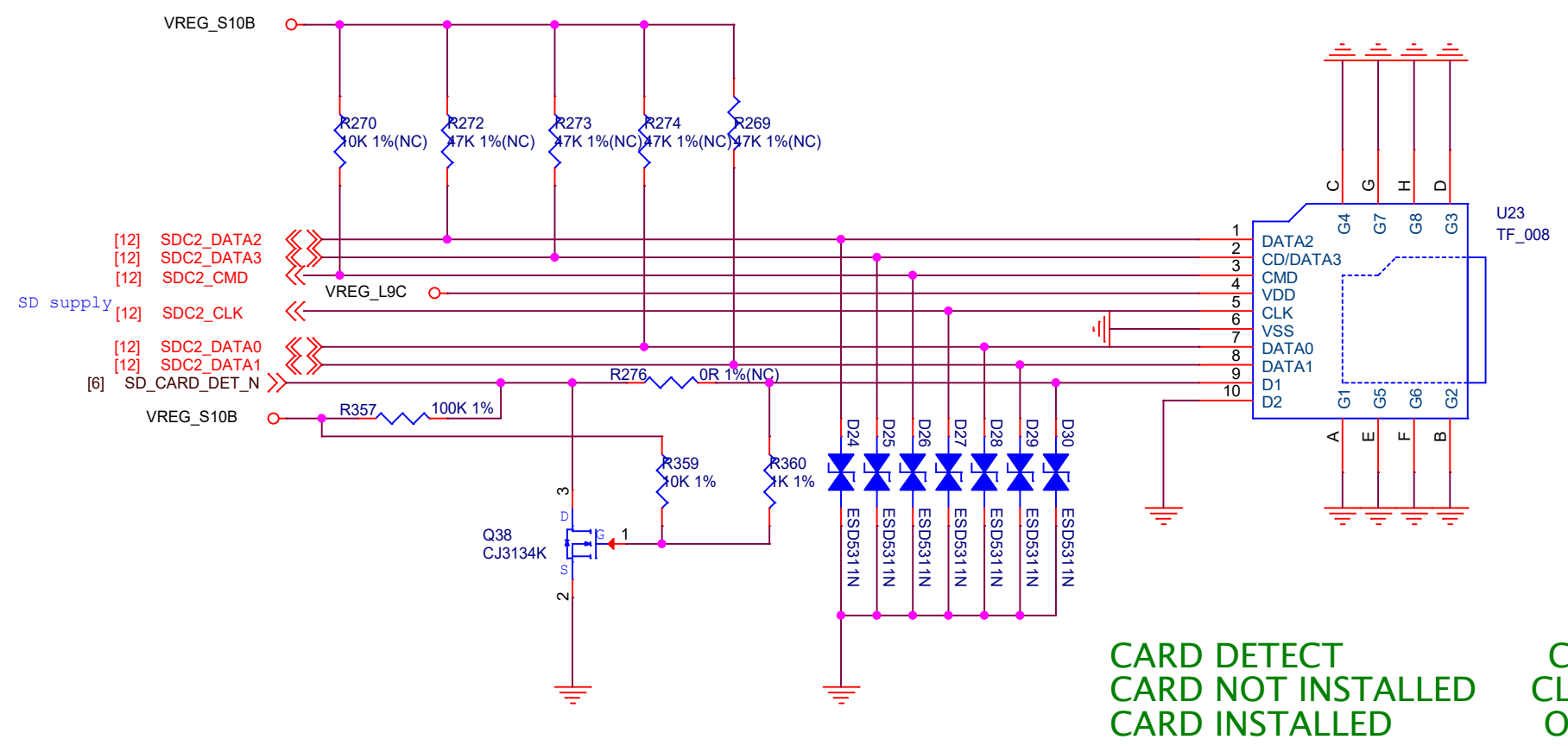
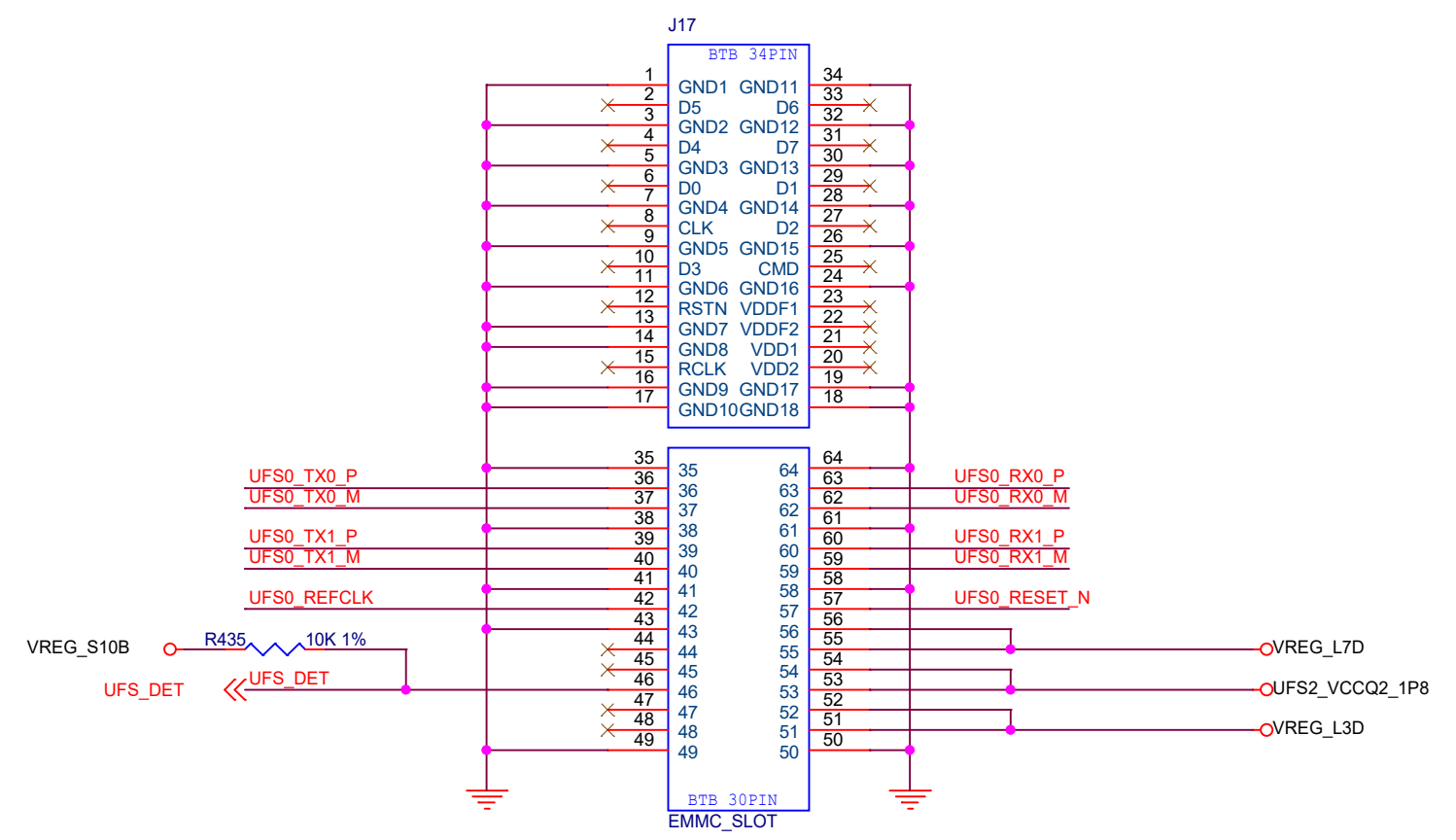
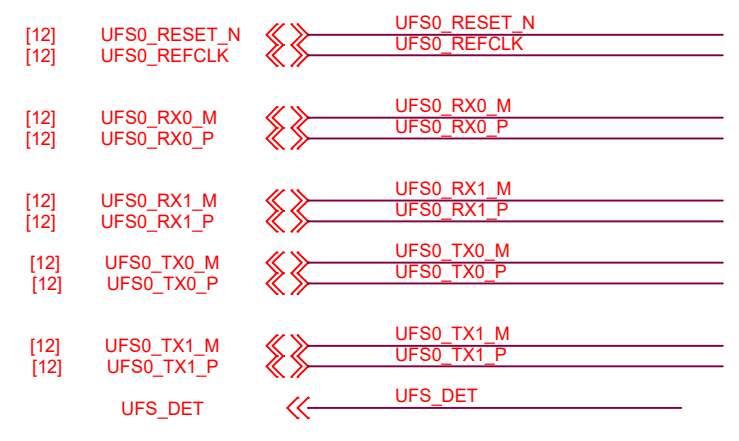

CARD DETECT
CARD NOT INSTALLED
CARD INSTALLED

CASE
CLOSED (GND)
OPEN (FLOATING)



M.2 EKEY

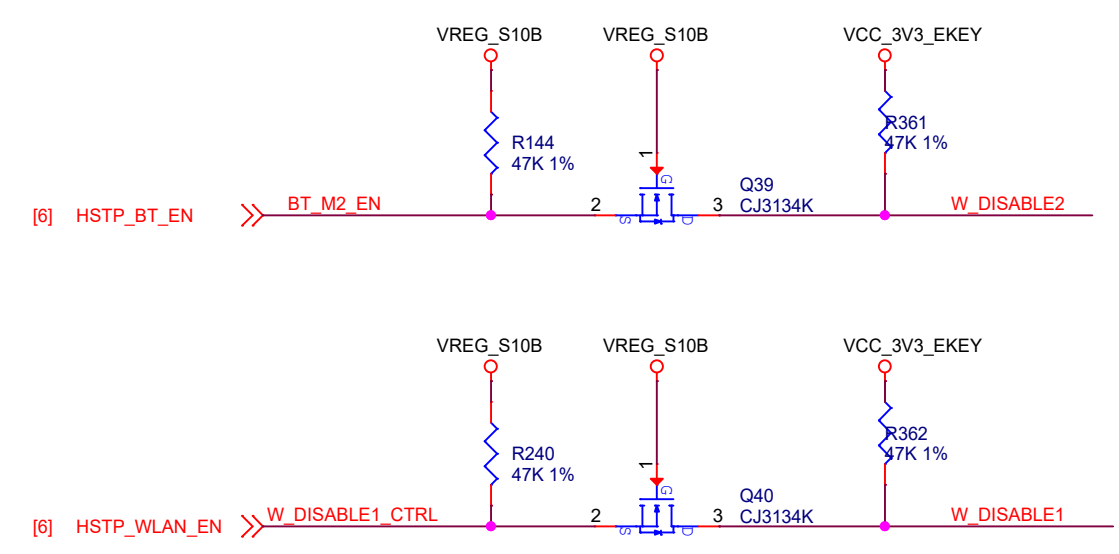
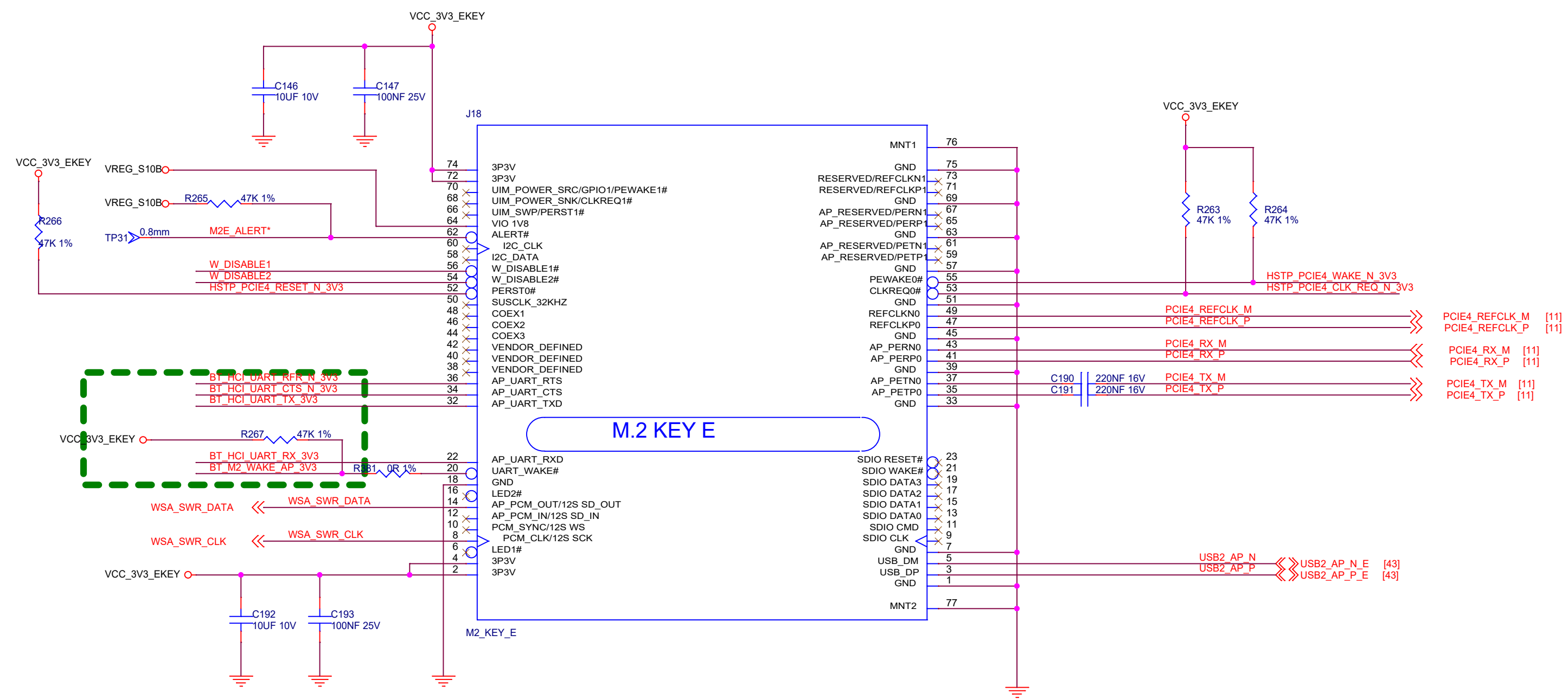

M2 J15_HOLE

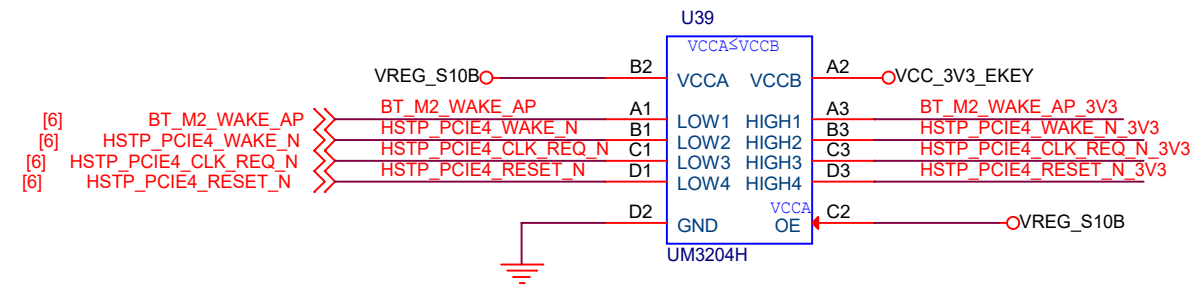
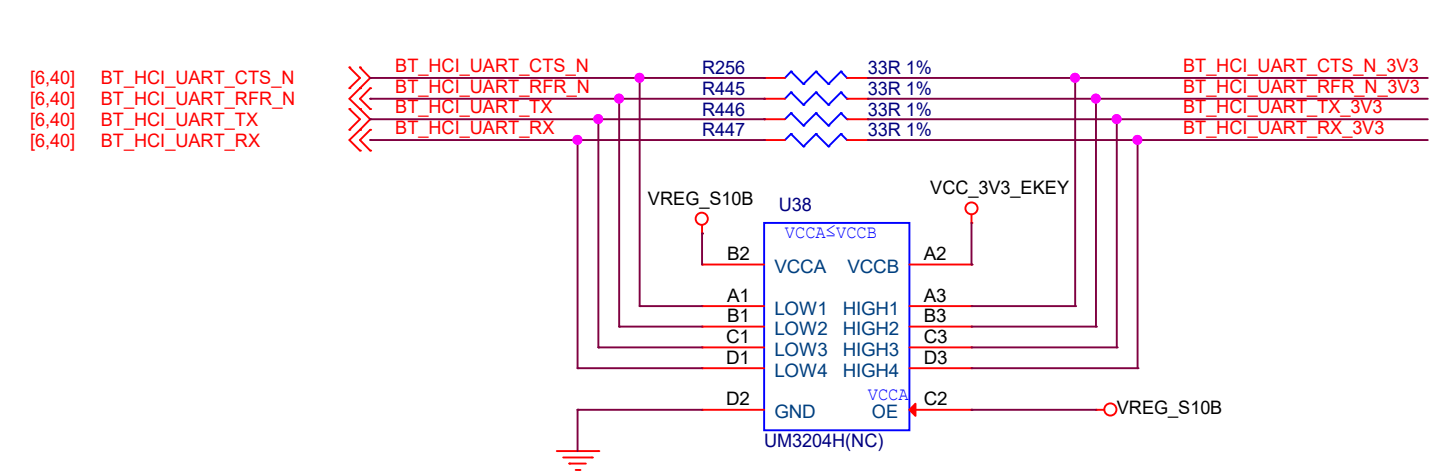
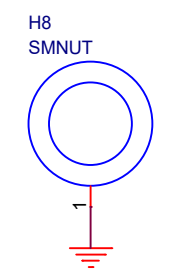

Size	Title: Radxa Dragon Q8	REV
C	Page Name: <Doc>	V1.3
Date:	Monday, June 22, 2026	Sheet 39 of 50

M.2 M KEY

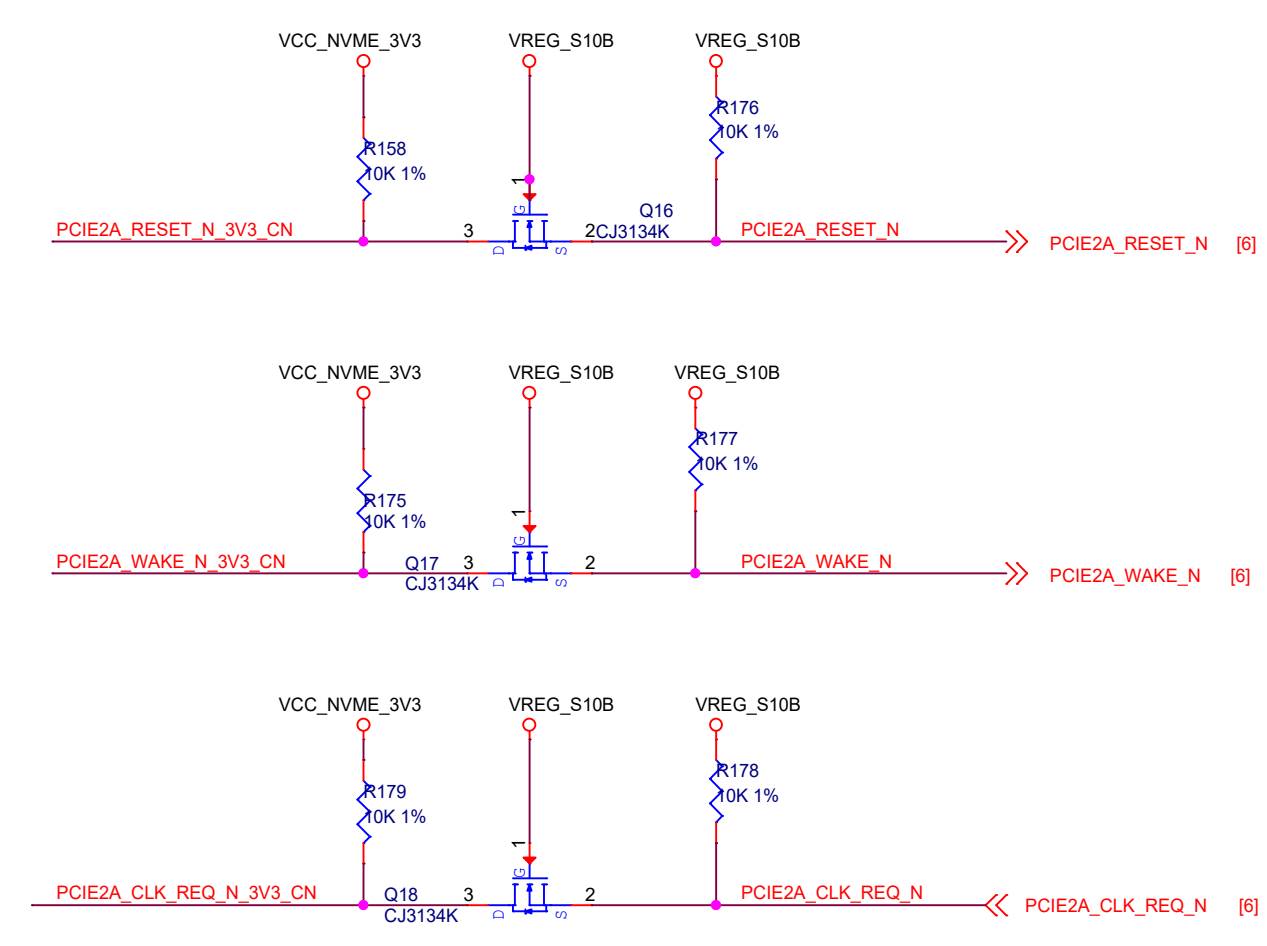
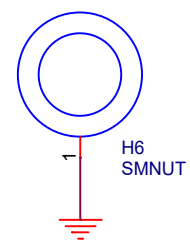
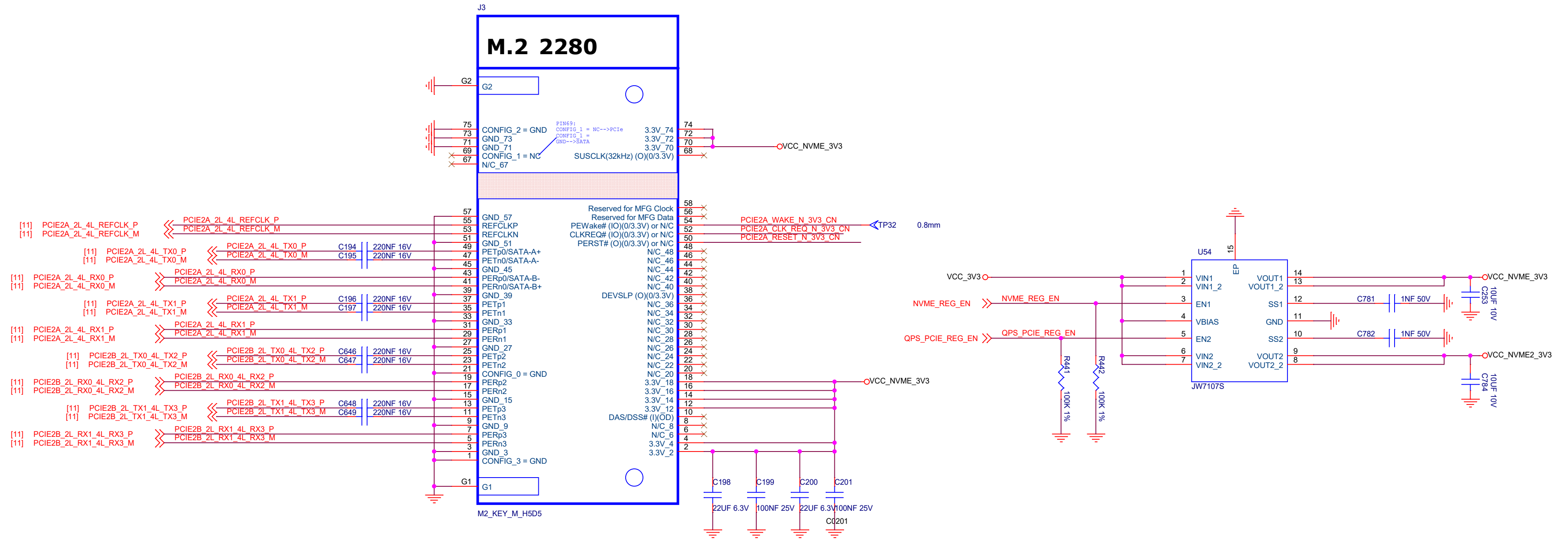

M.2_M-KEY_2

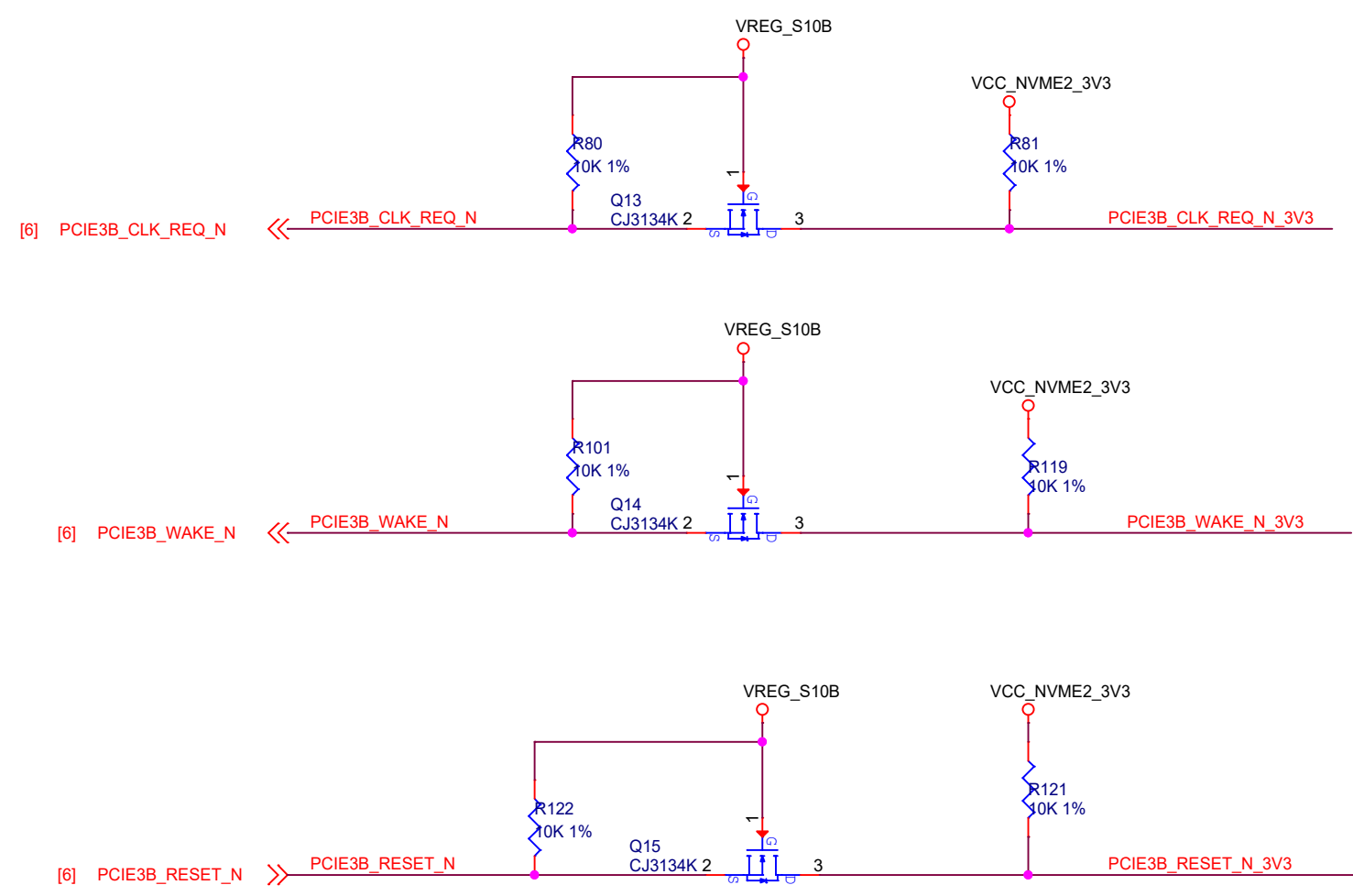
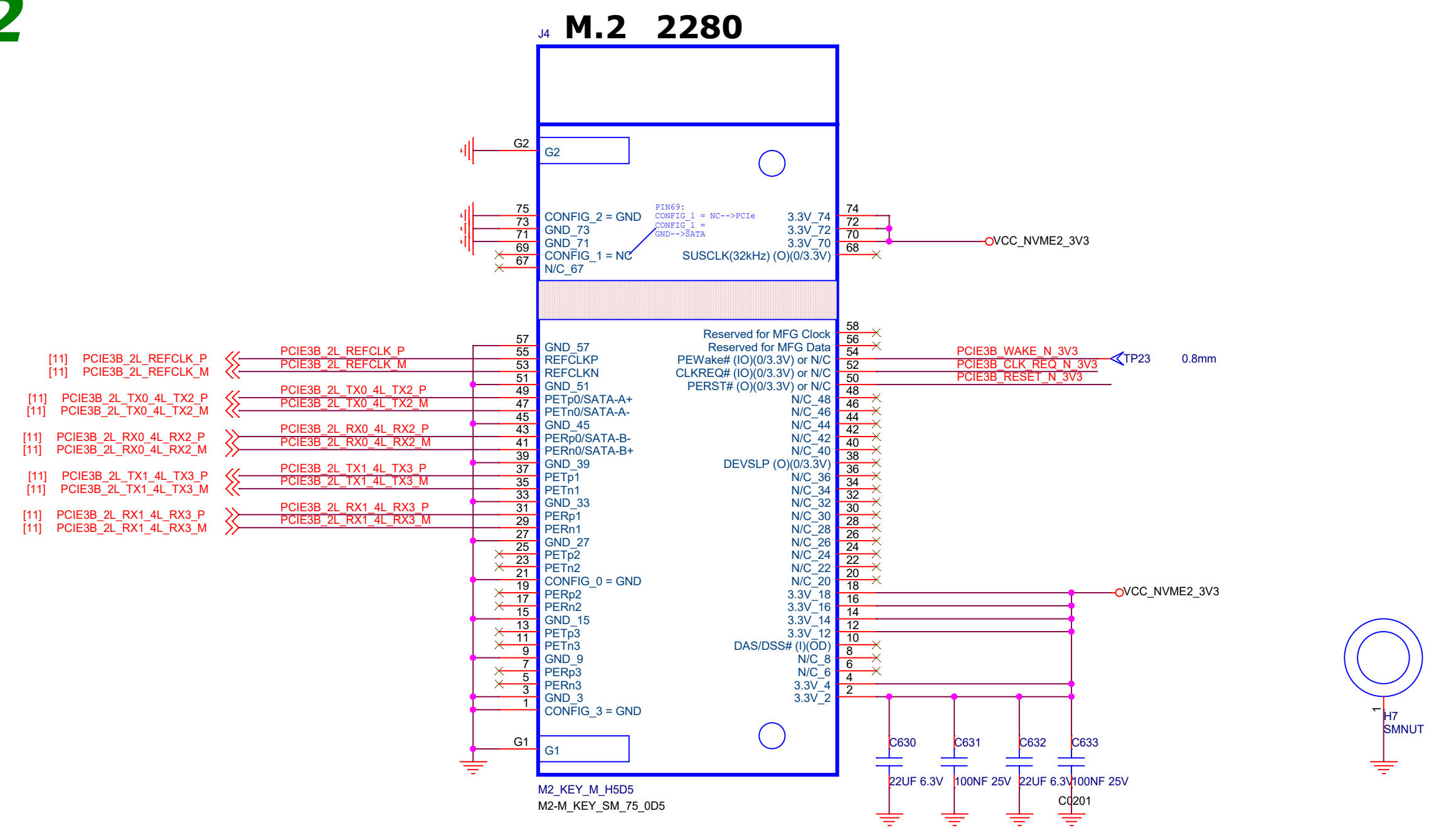

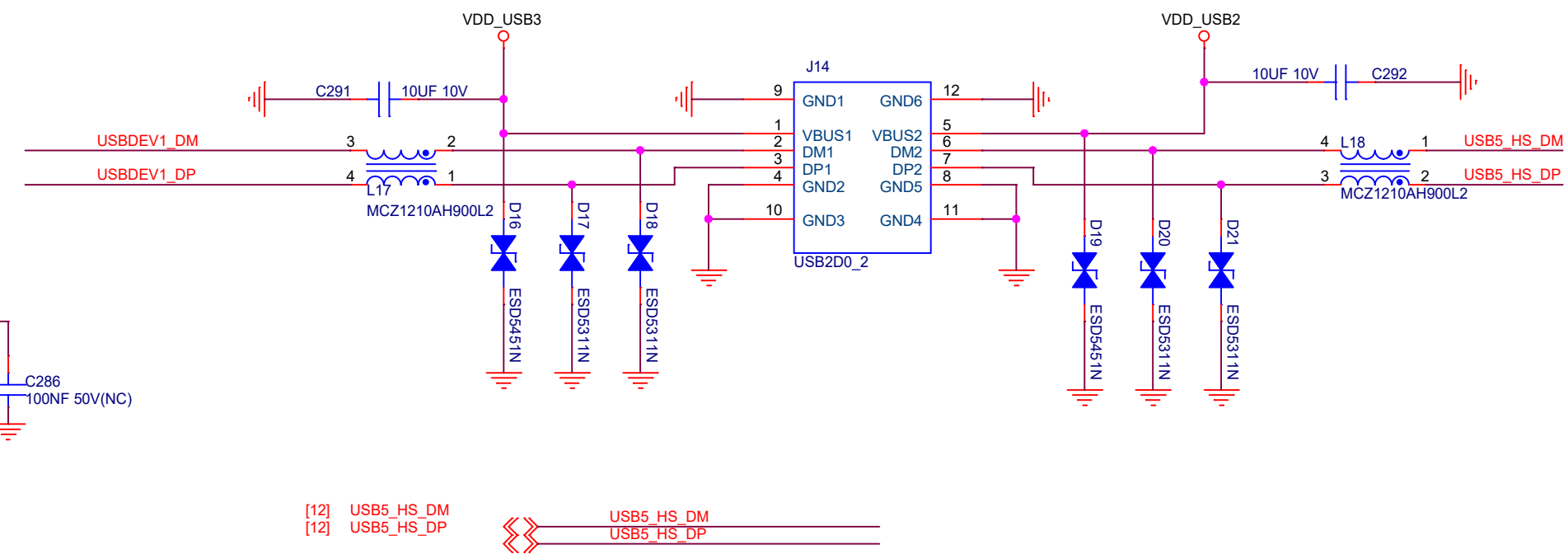
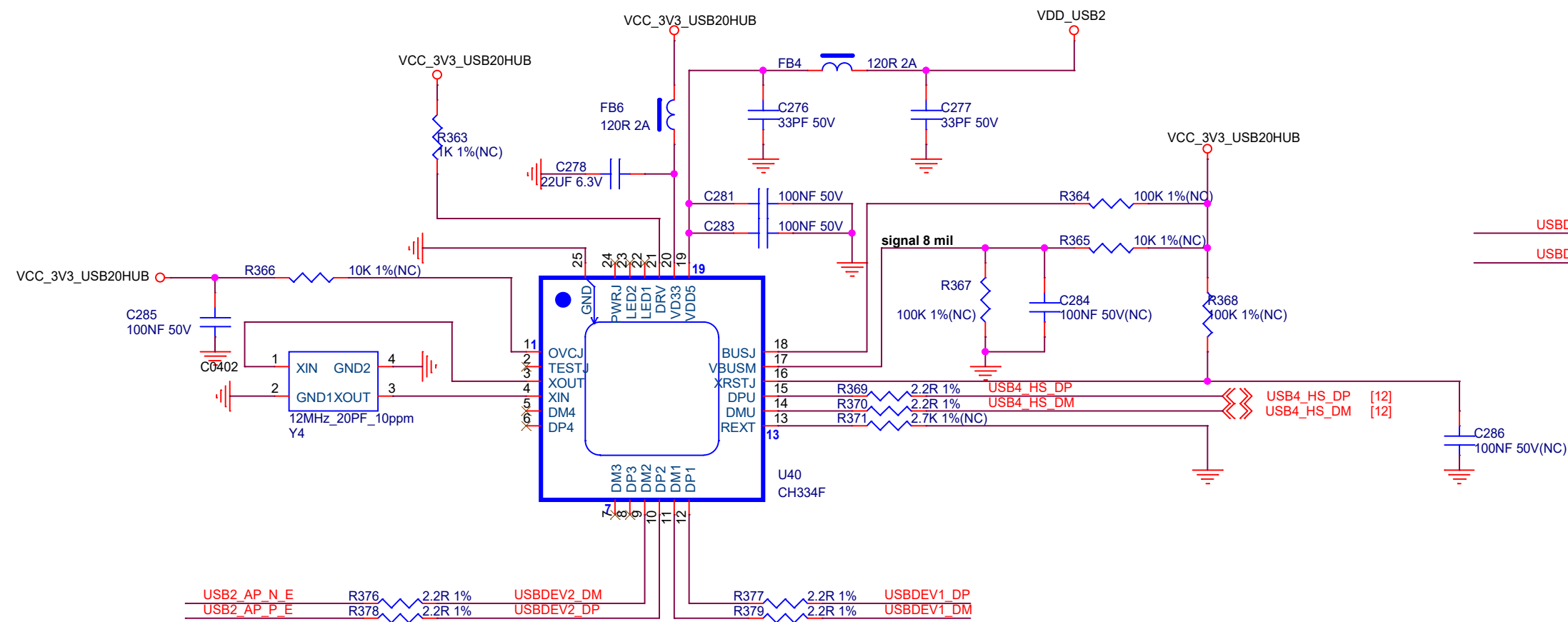
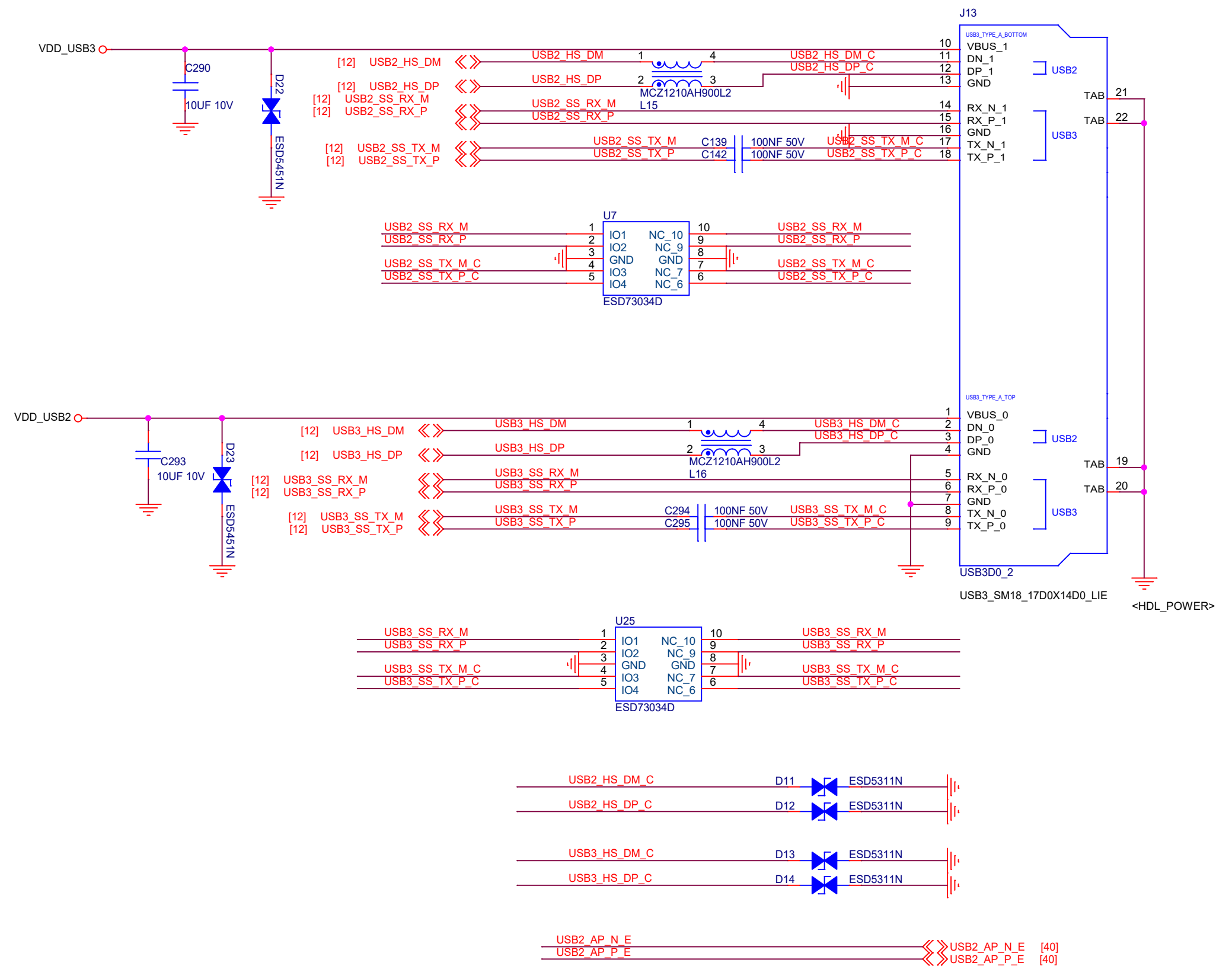
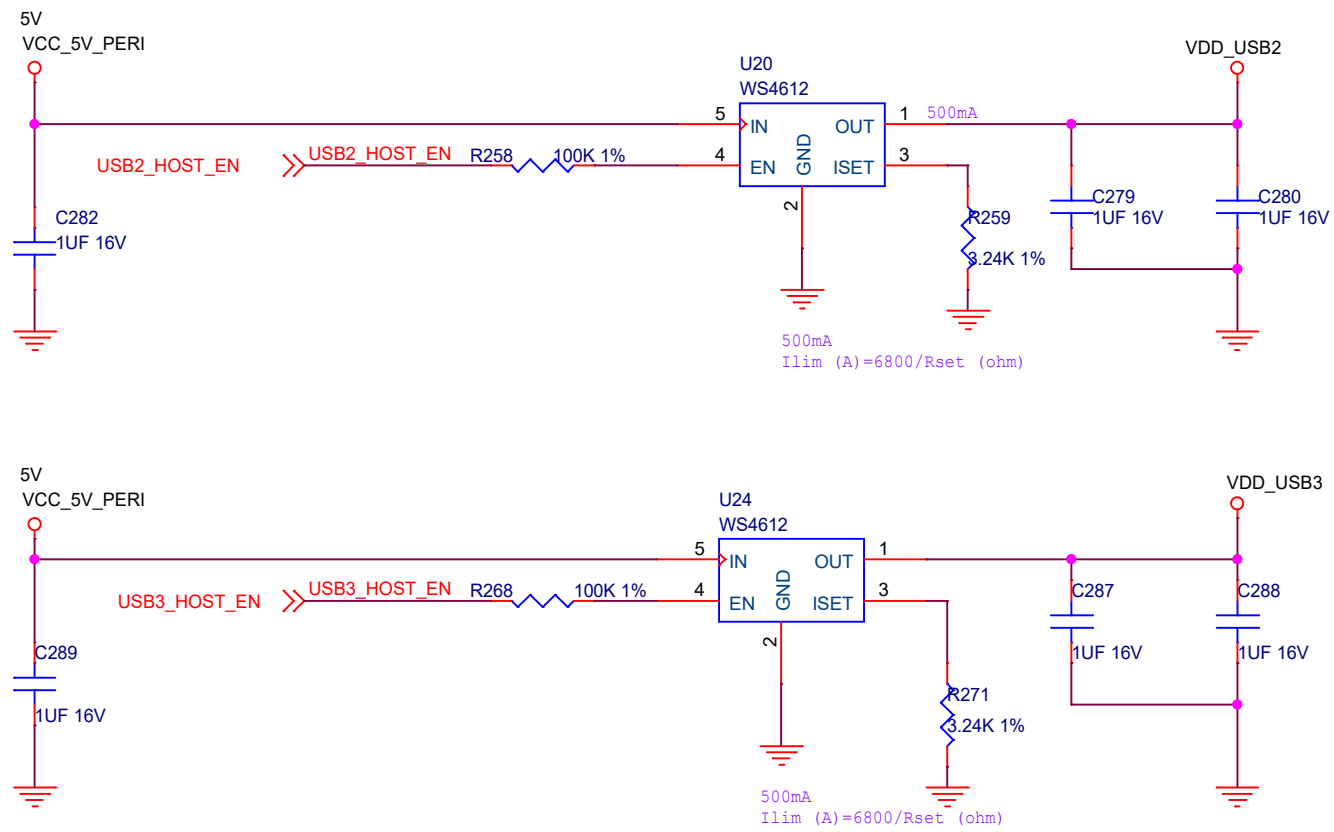

DP TO HDMI

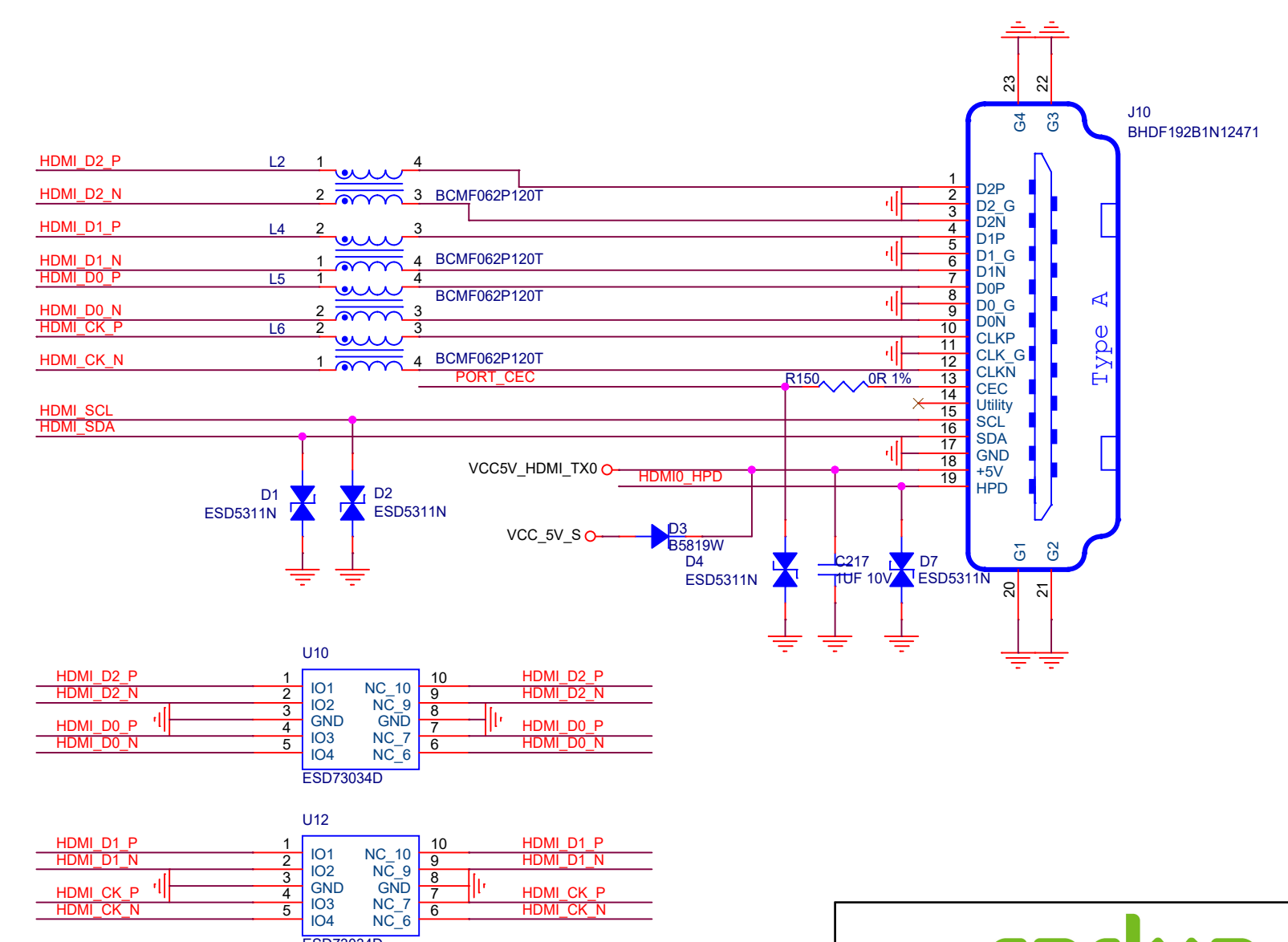
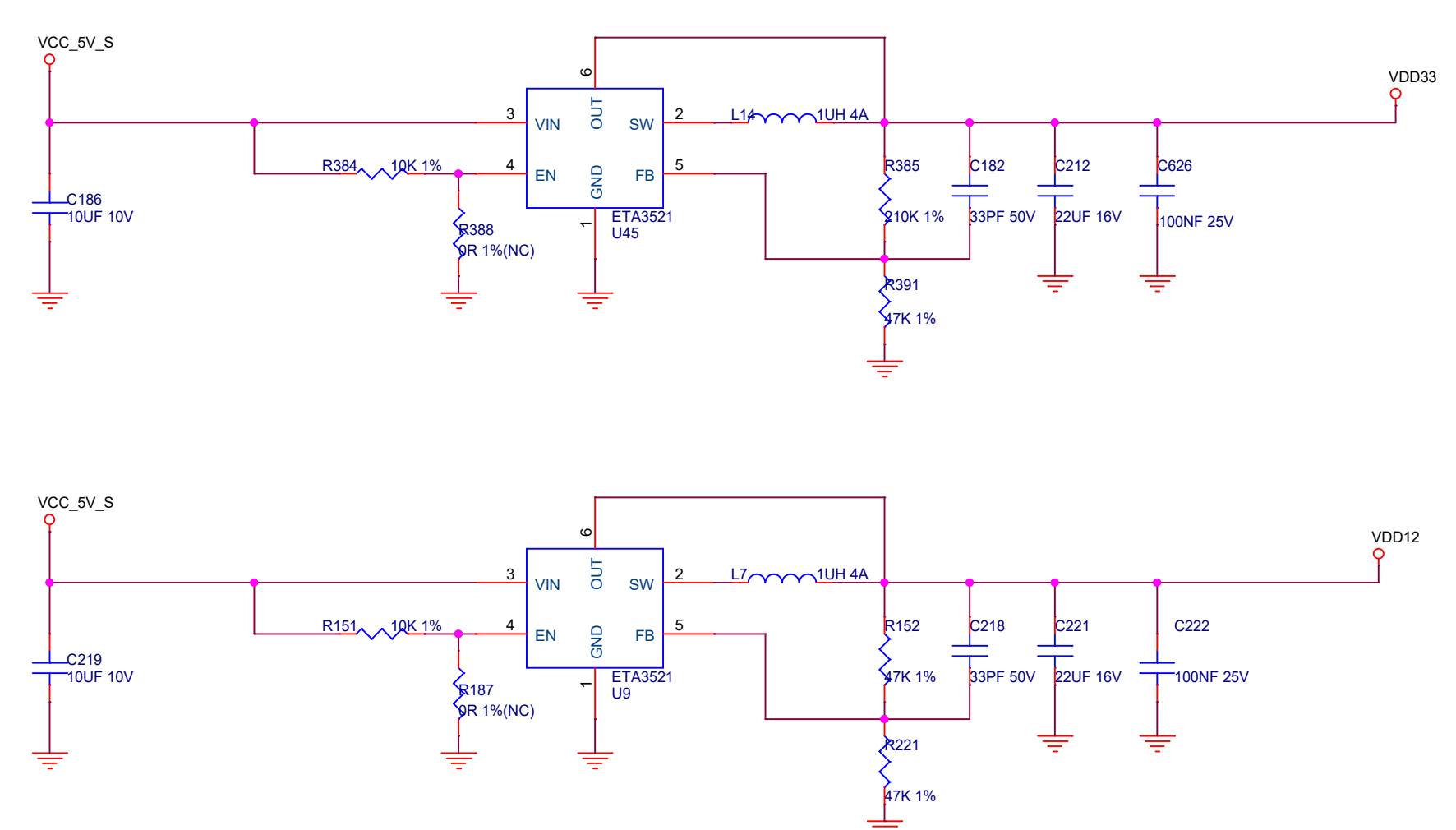
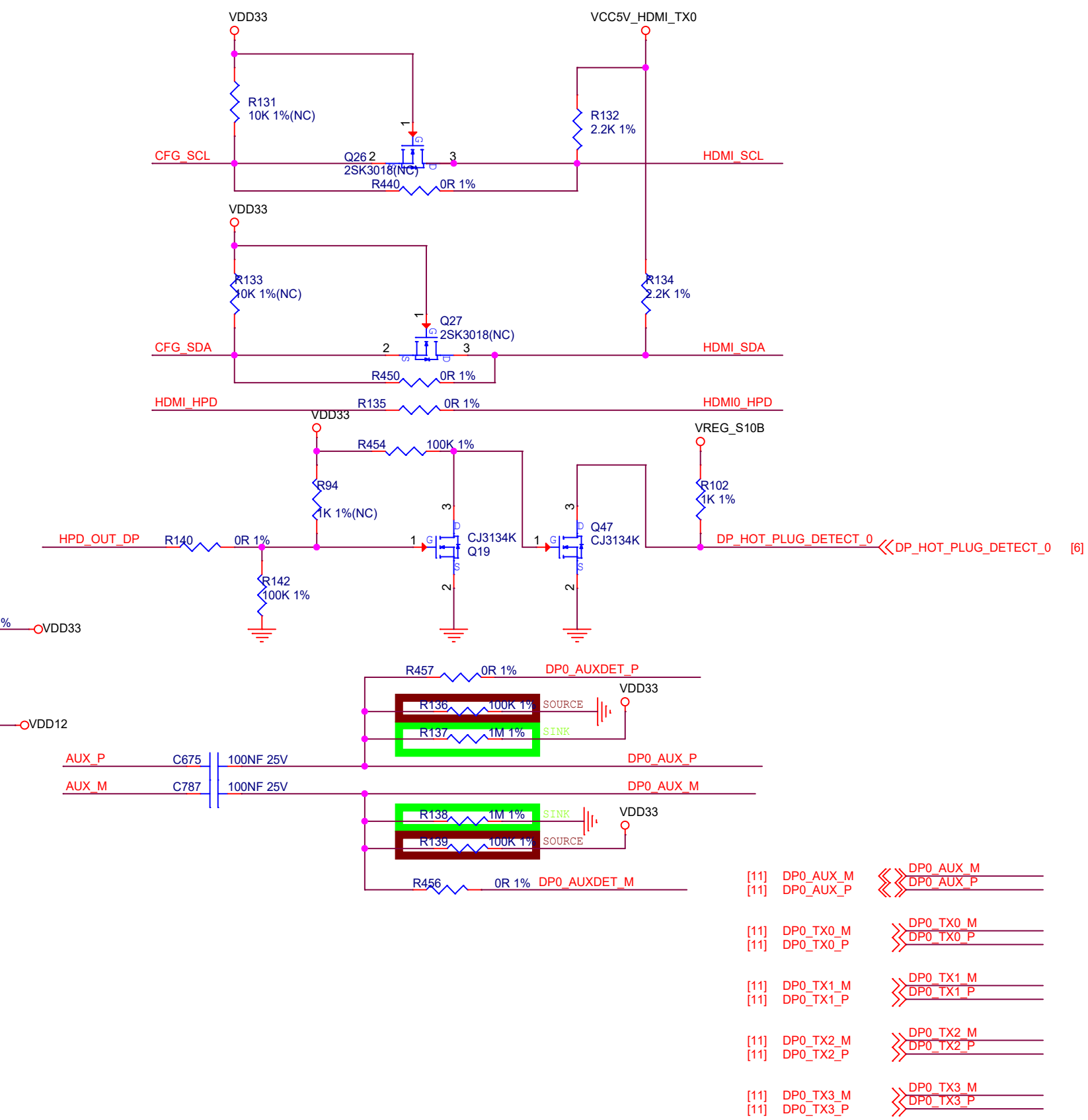
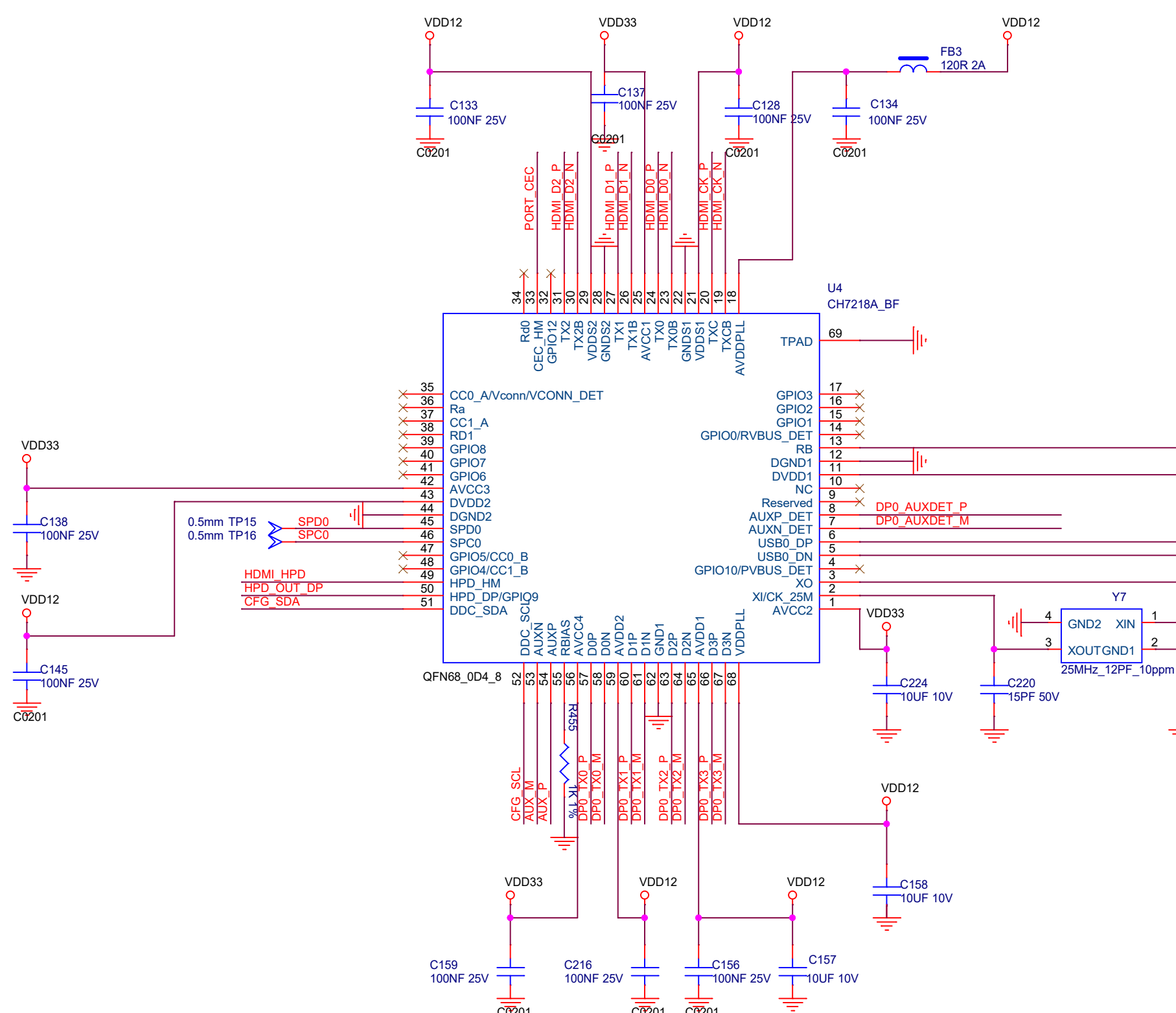

radxa

Size	Title:	Radxa Dragon Q8	REV
C	Page Name:	<Doc>	V1.3
Date:	Monday, June 22, 2026	Sheet 43 of 50	

TYPEC-IN

R227	3V
6.8K	3V
24K	12V
56K	15V
NC	20V

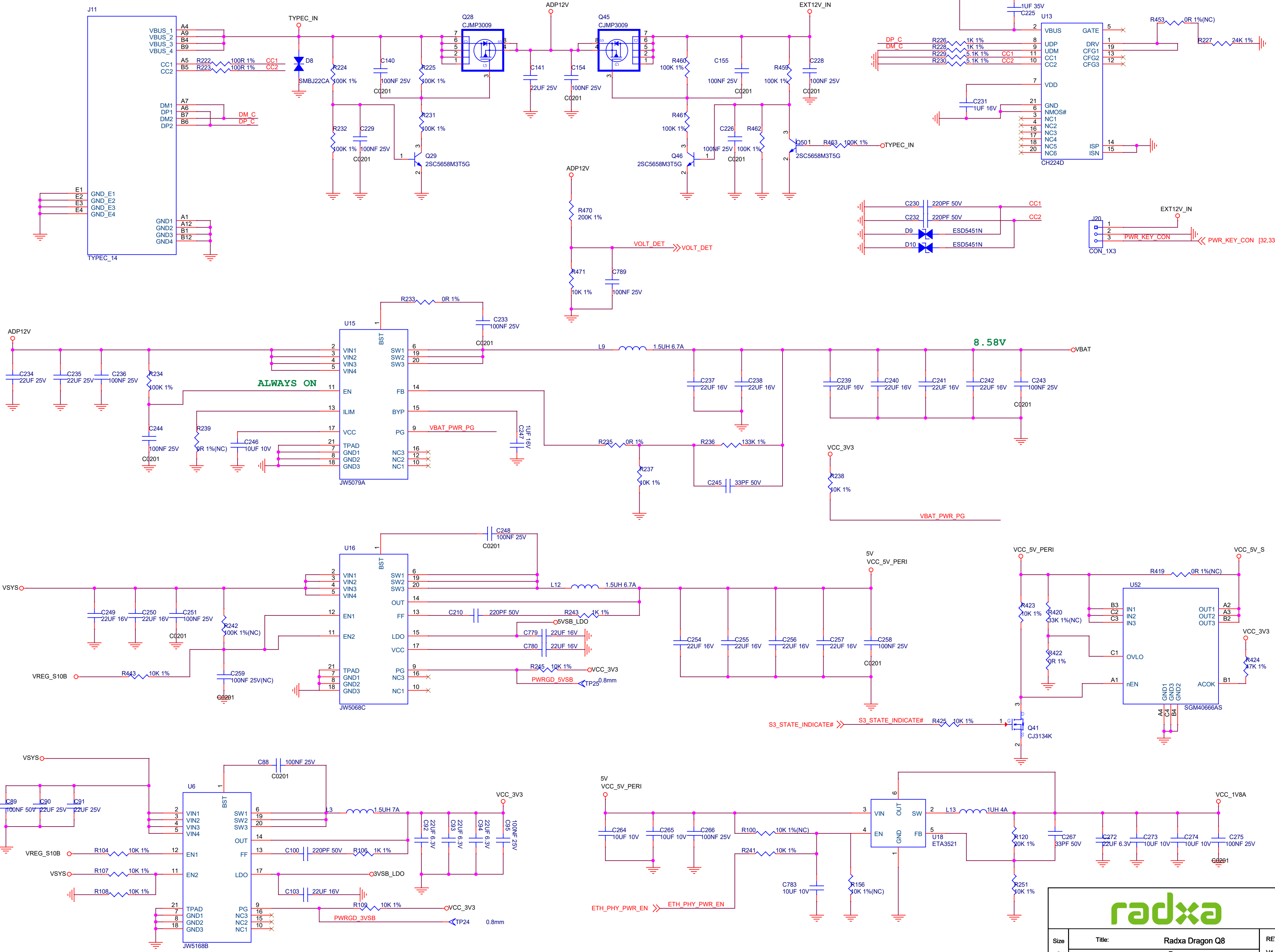

radxa

Size	Title: Radxa Dragon Q8	REV
C	Page Name: <Doc>	V1.3
Date: Monday, June 22, 2026	Sheet 44 of 50	

PCIE BRIDGE

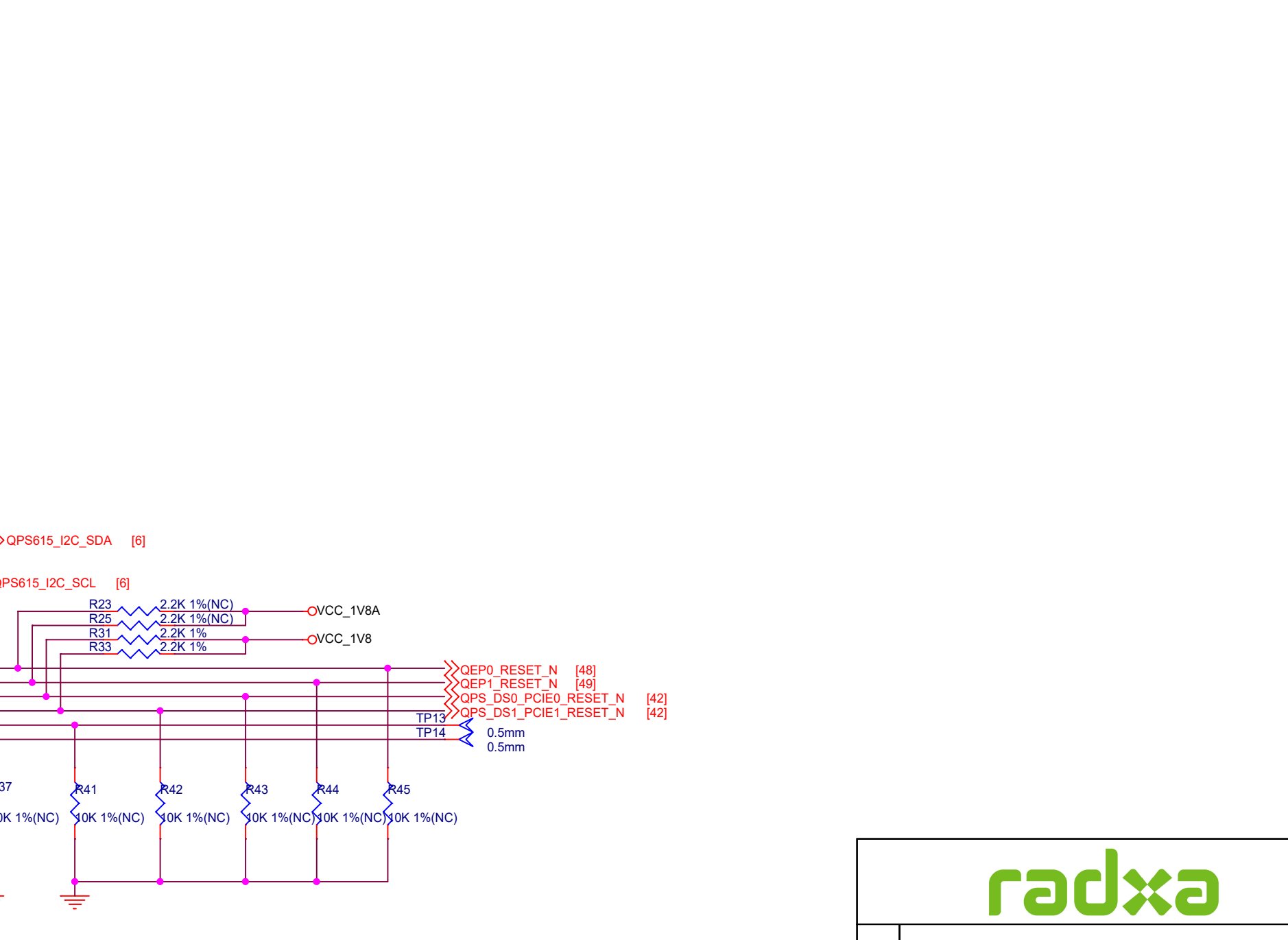
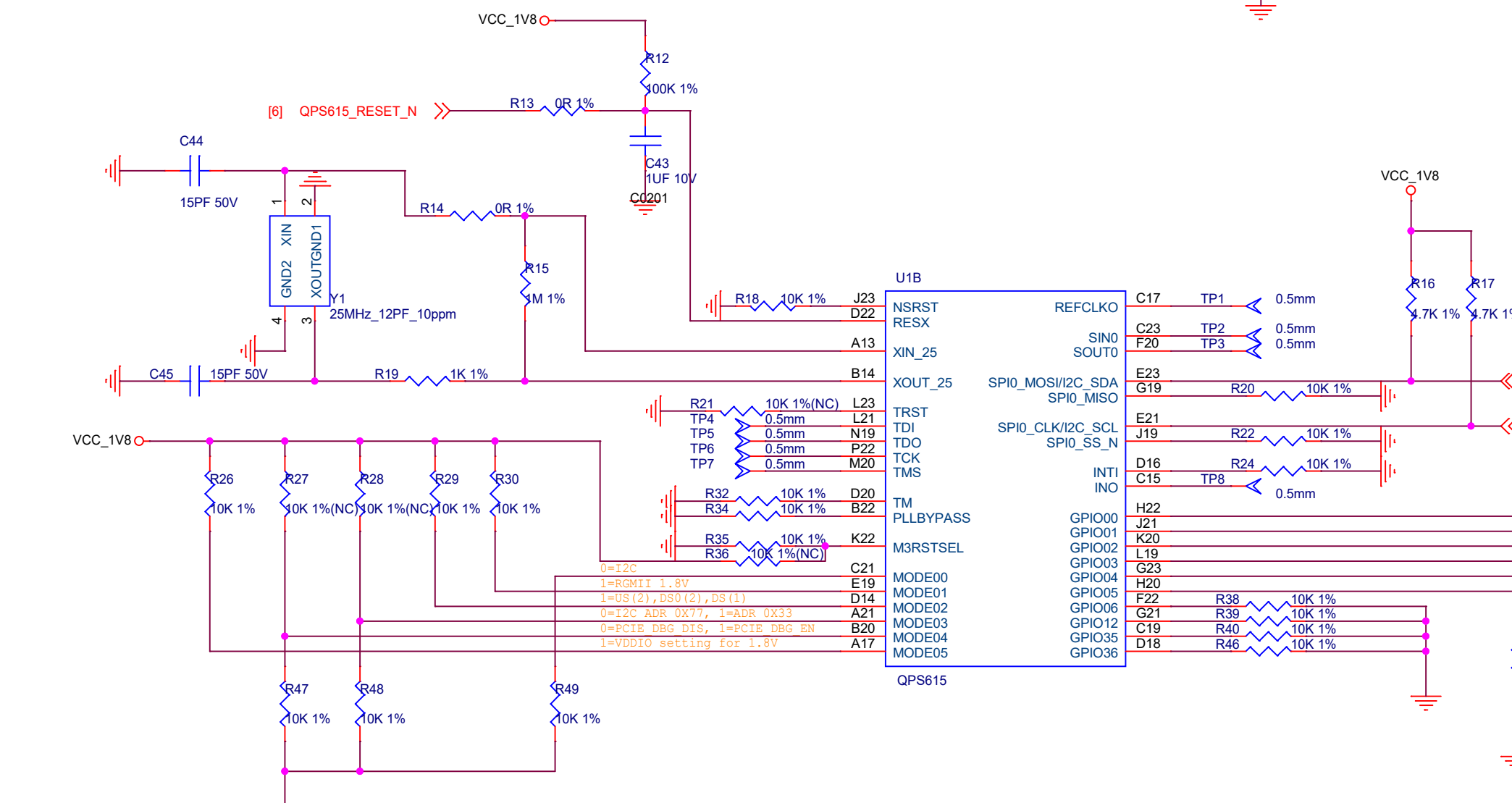
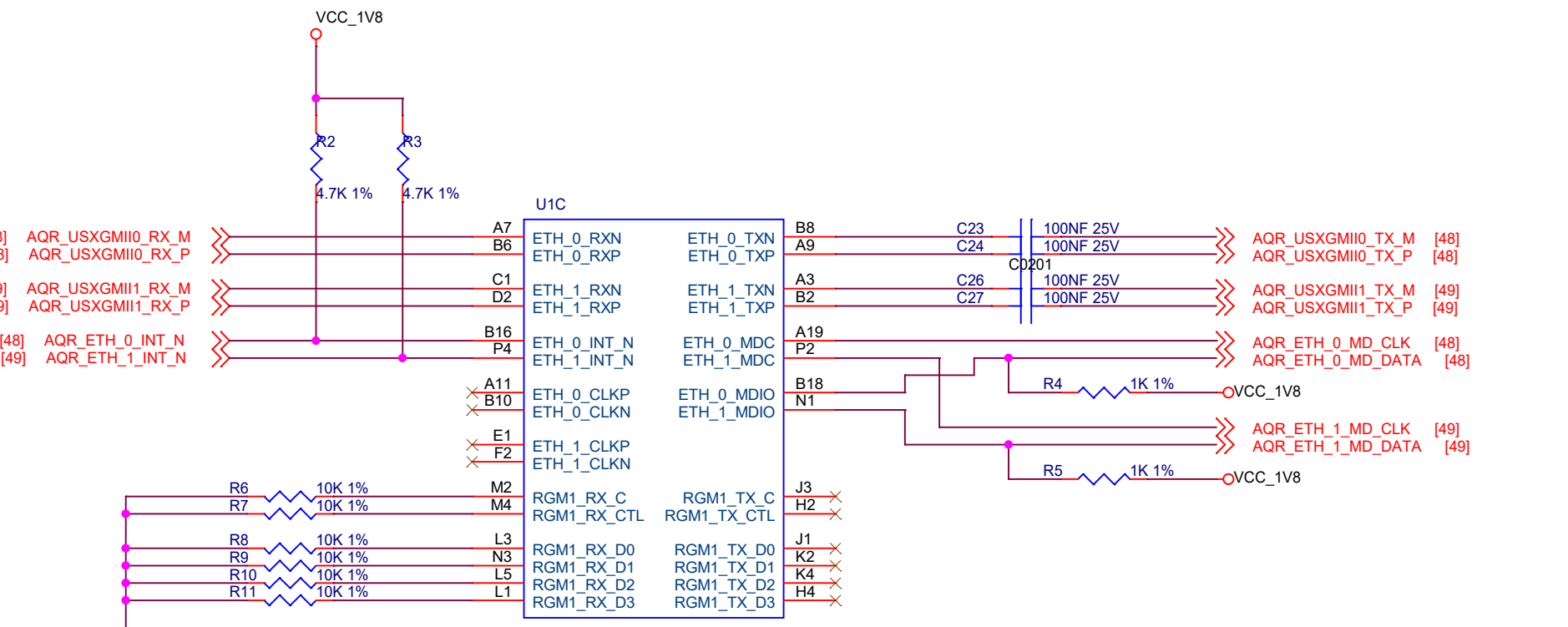
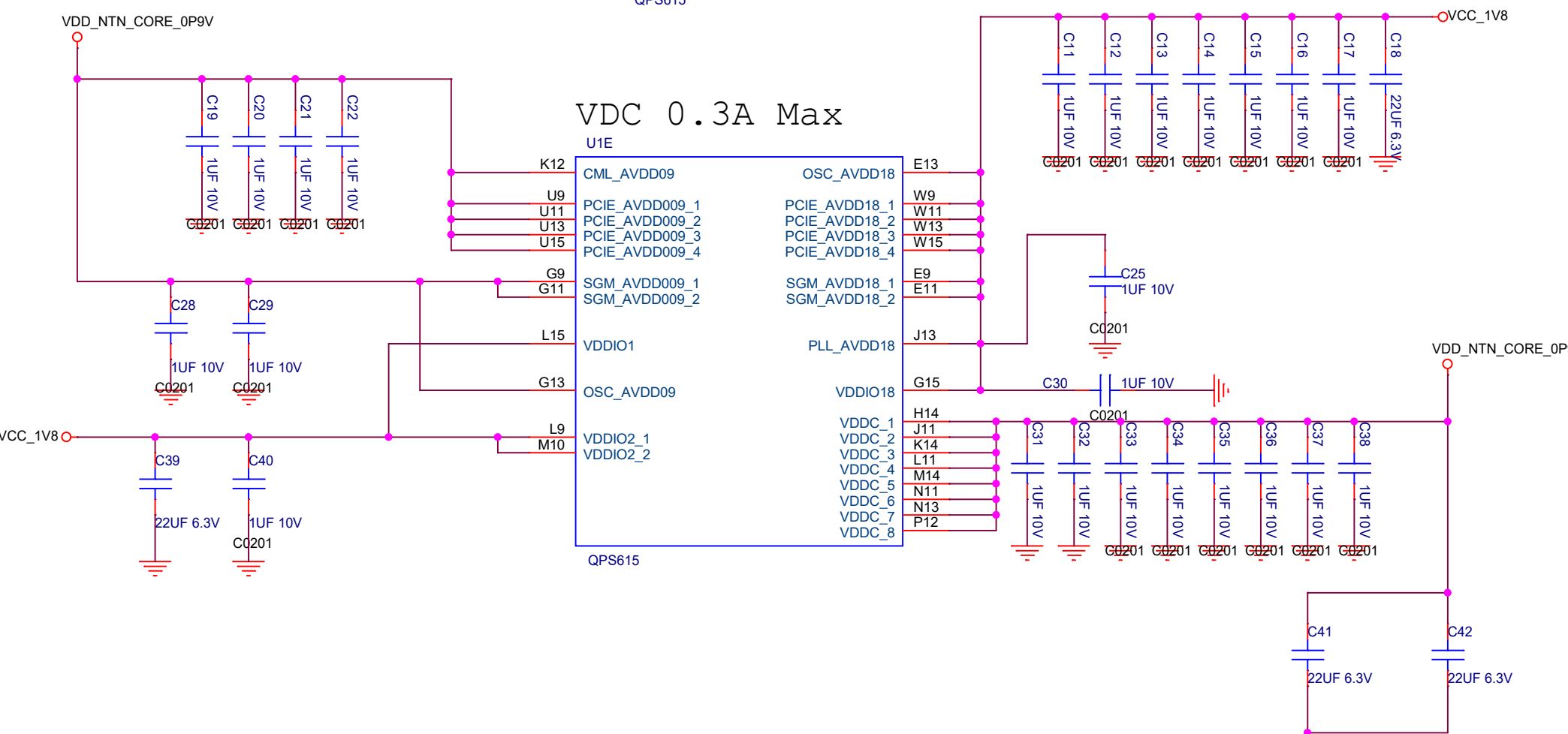
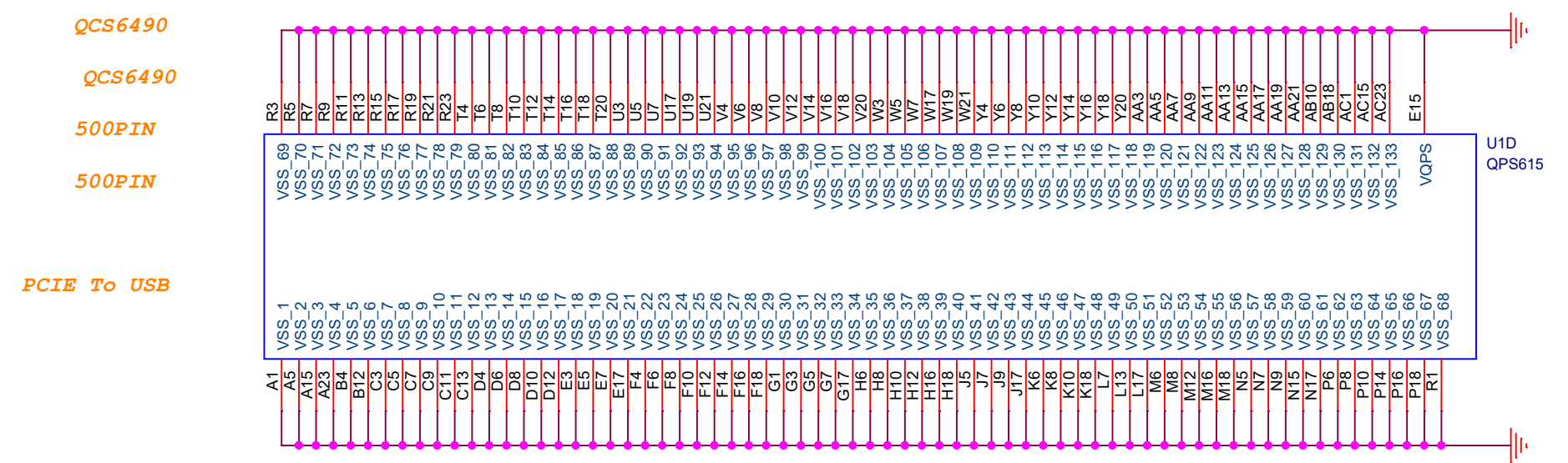
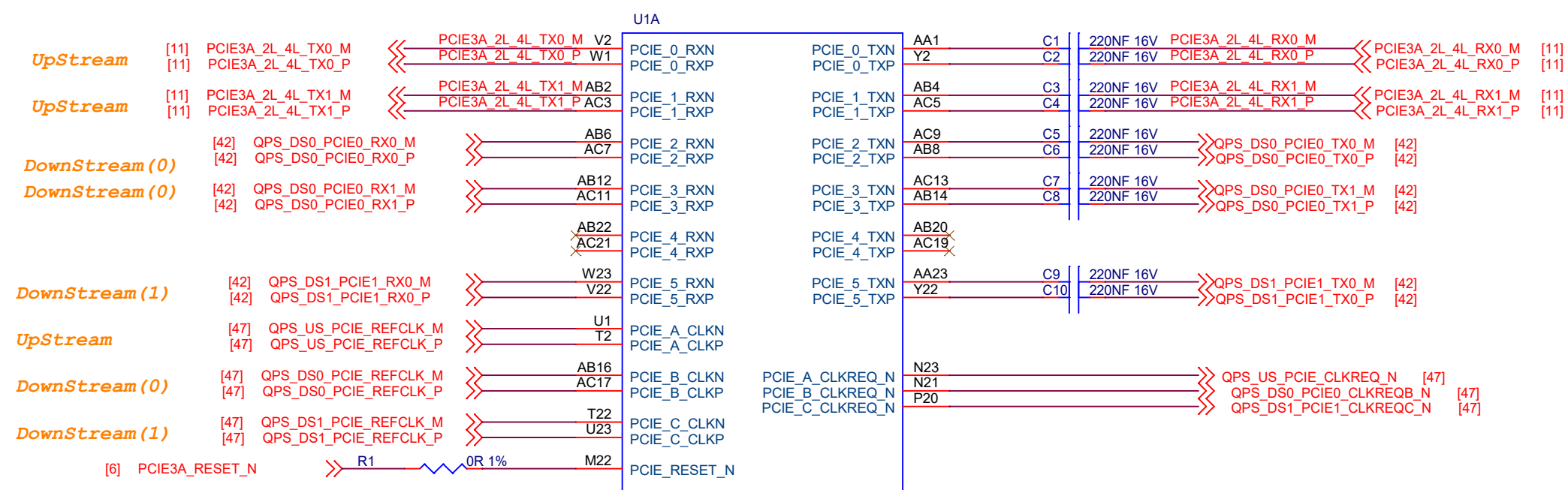

Size	Title:	Radxa Dragon Q8	REV
C	Page Name:	<Doc>	V1.3
Date:	Monday, June 22, 2026	Sheet	45 of 50

PCIE BRIDGE_2

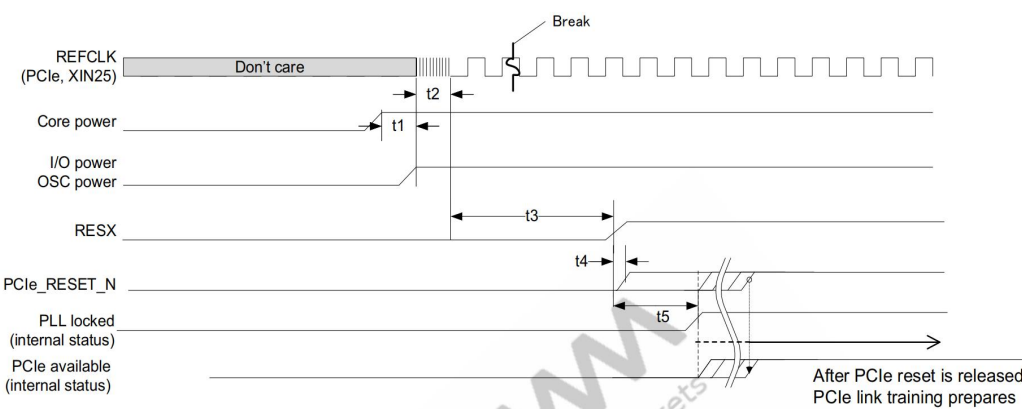
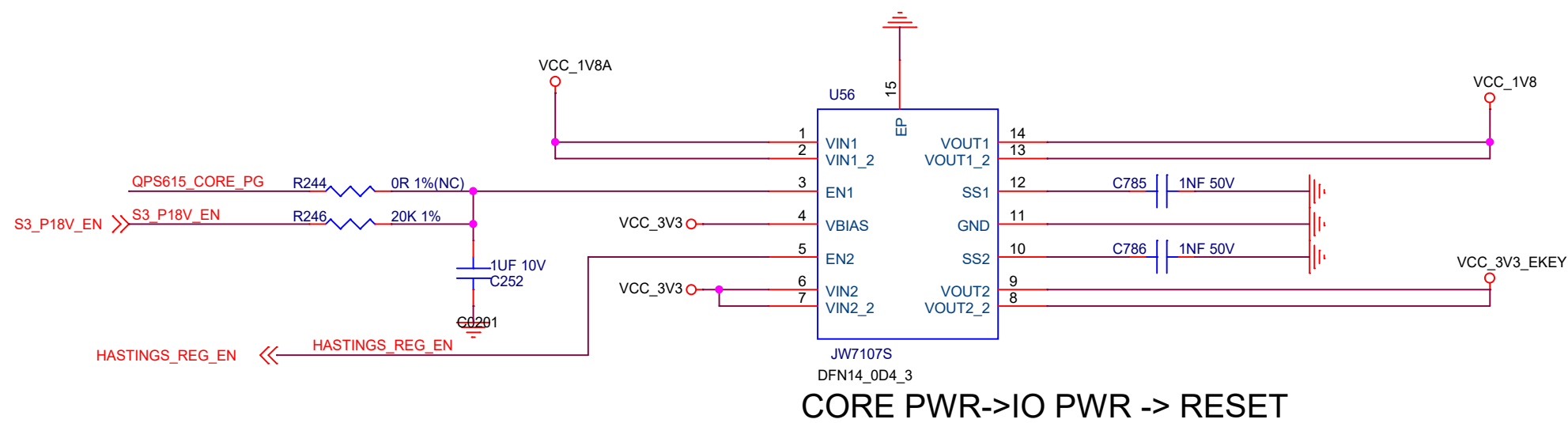
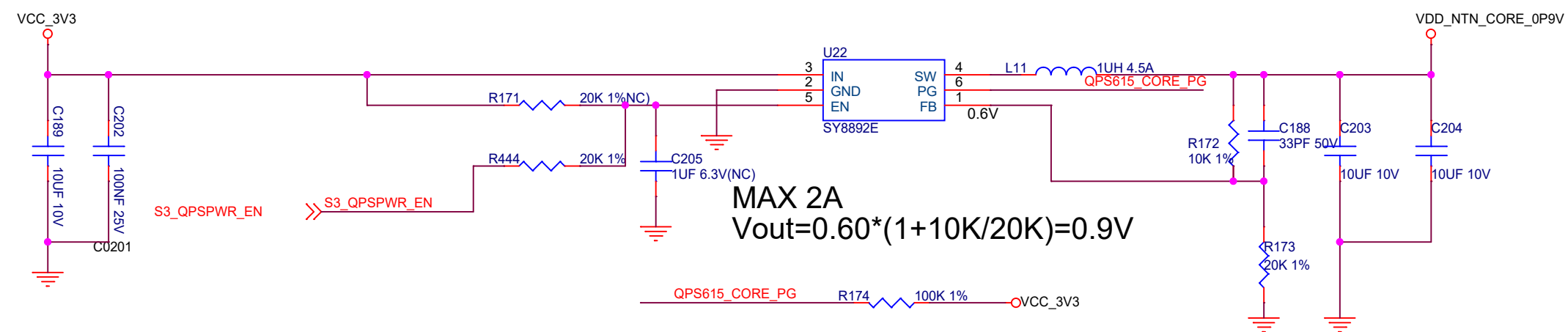
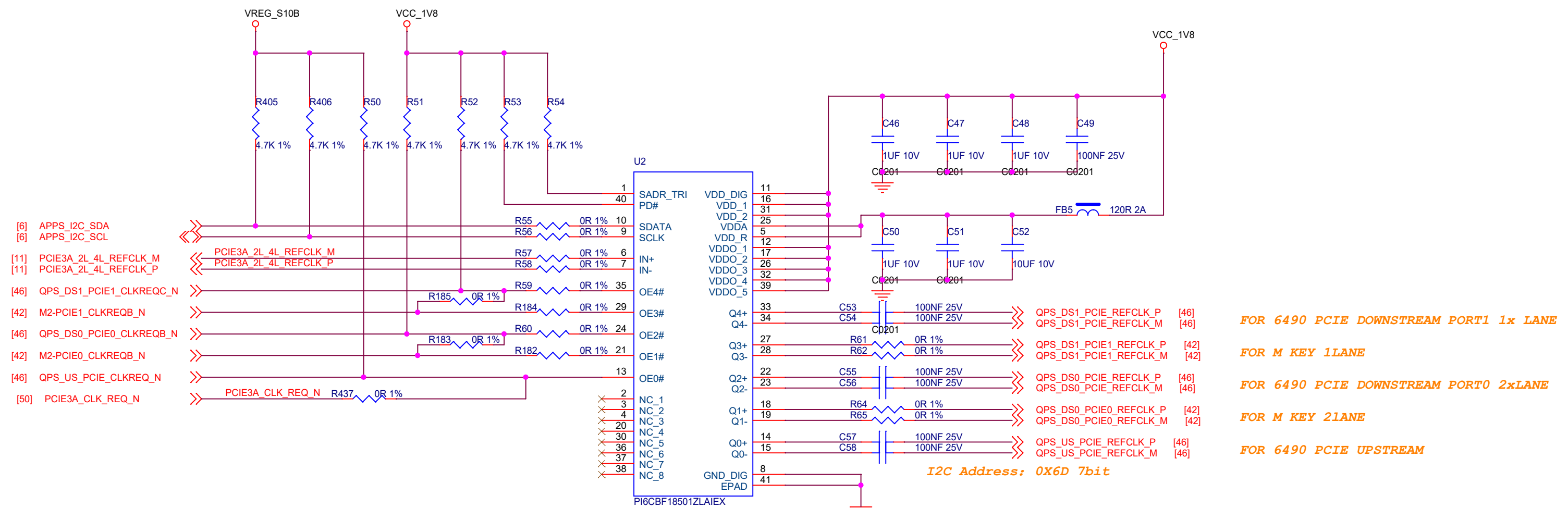

radxa

Size	Title: Radxa Dragon Q8	REV
C	Page Name: <Doc>	V1.3
Date:	Monday, June 22, 2026	Sheet 46 of 50

ETH_2.5G_0

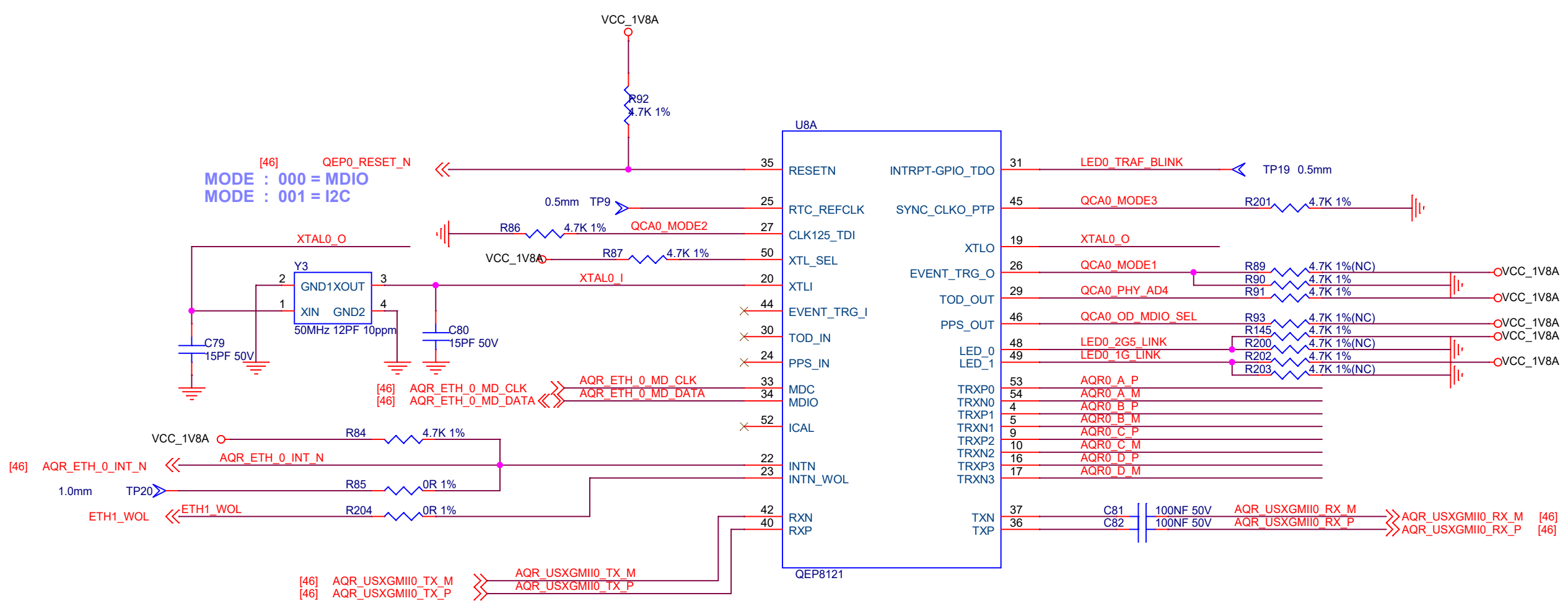
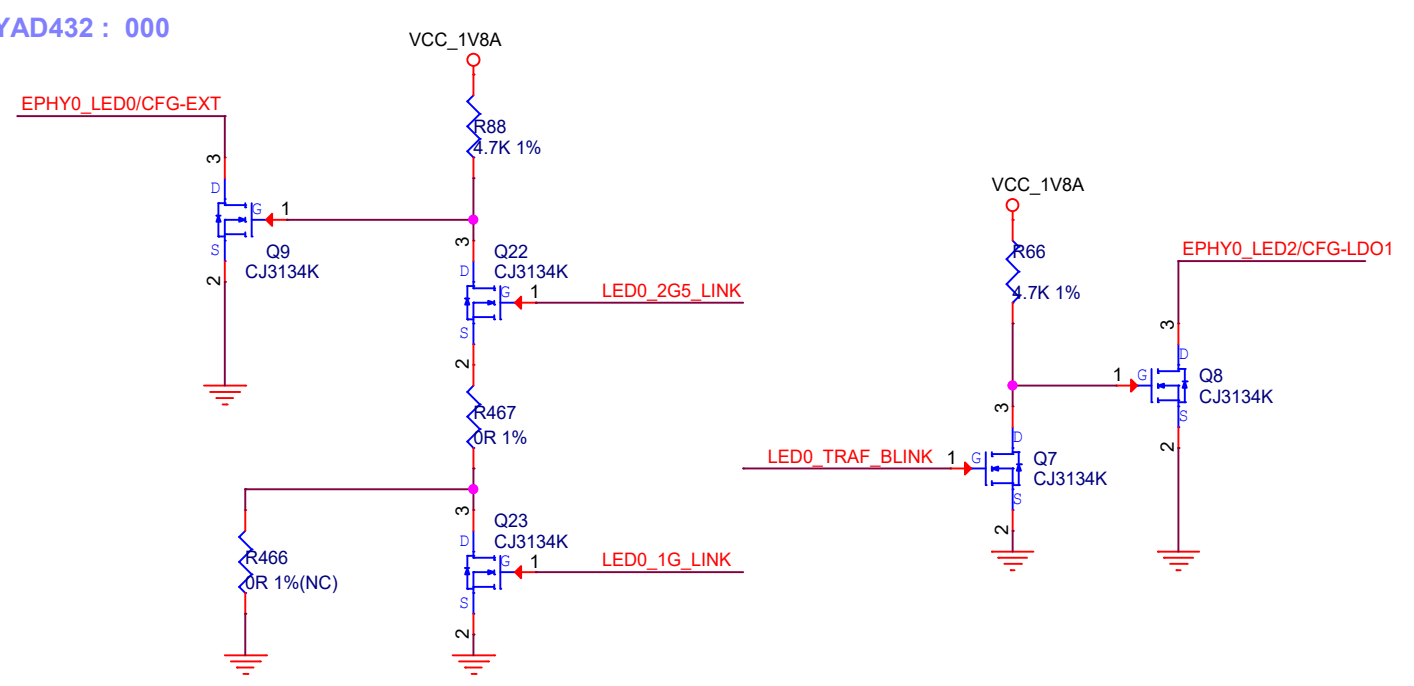
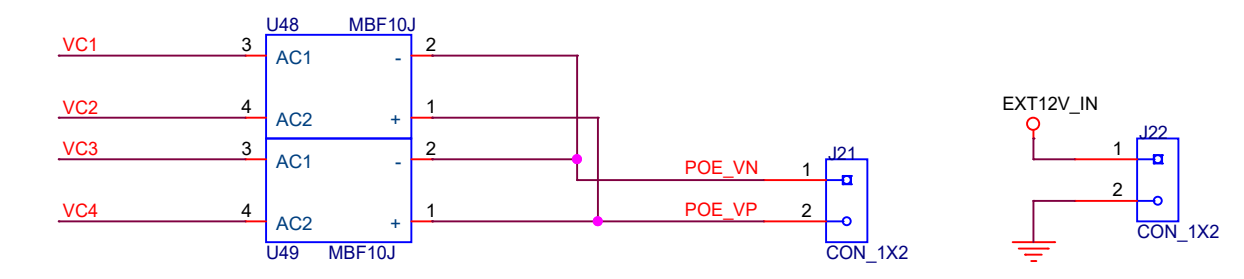
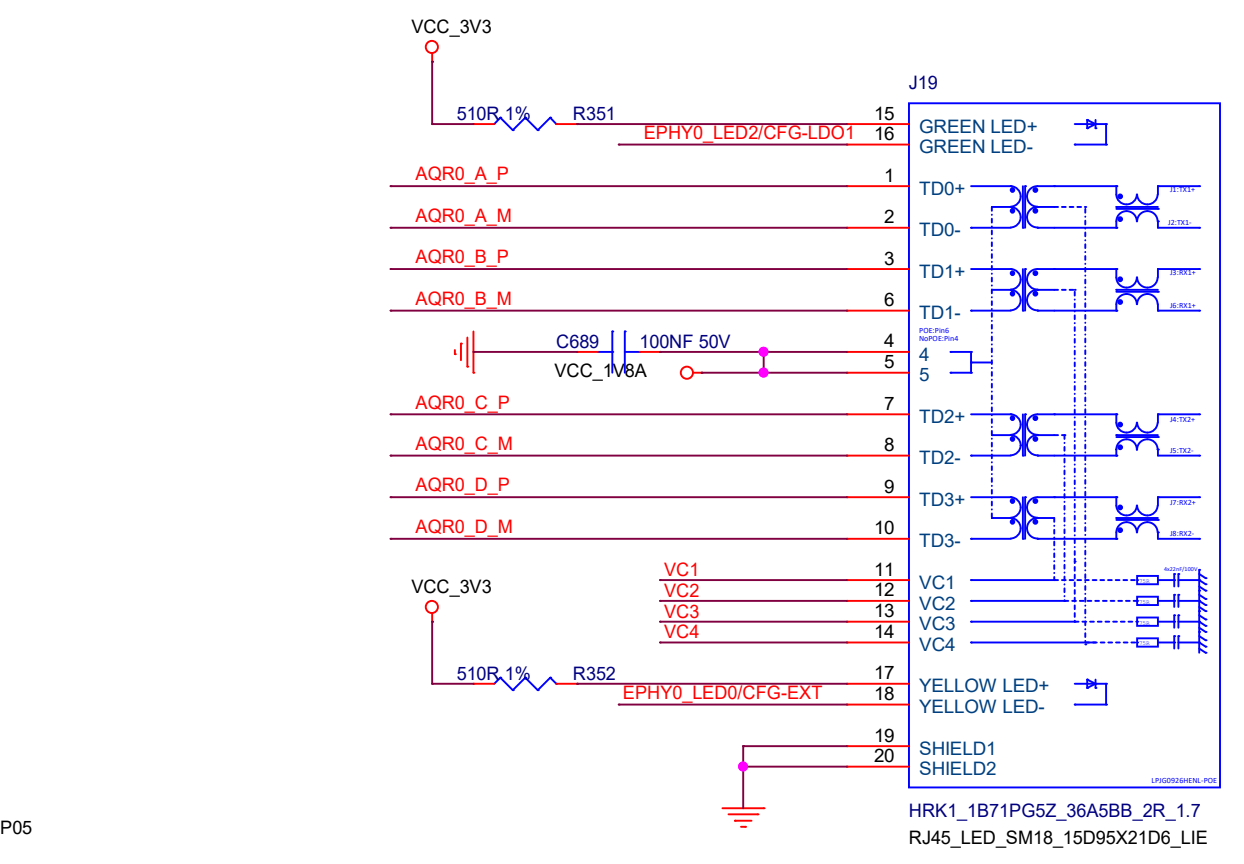
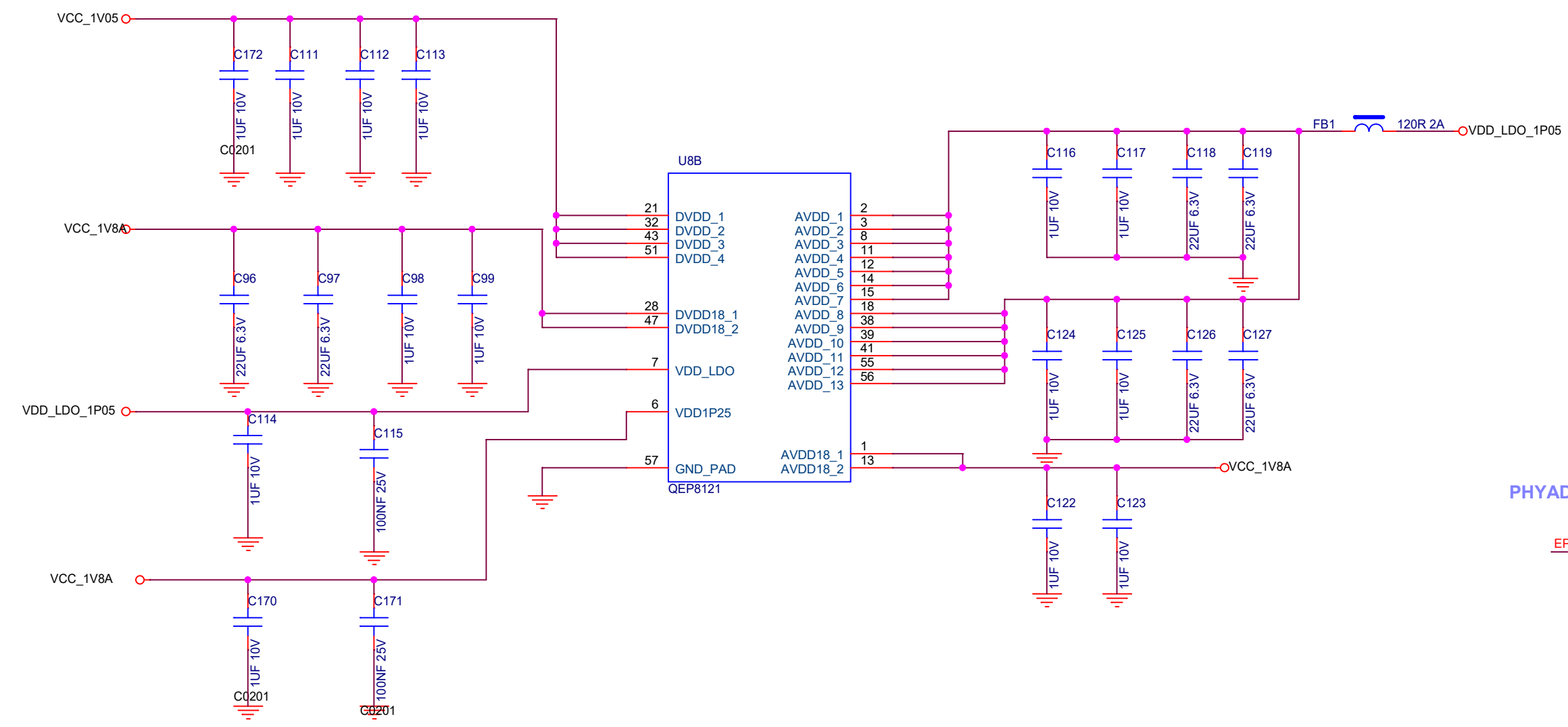
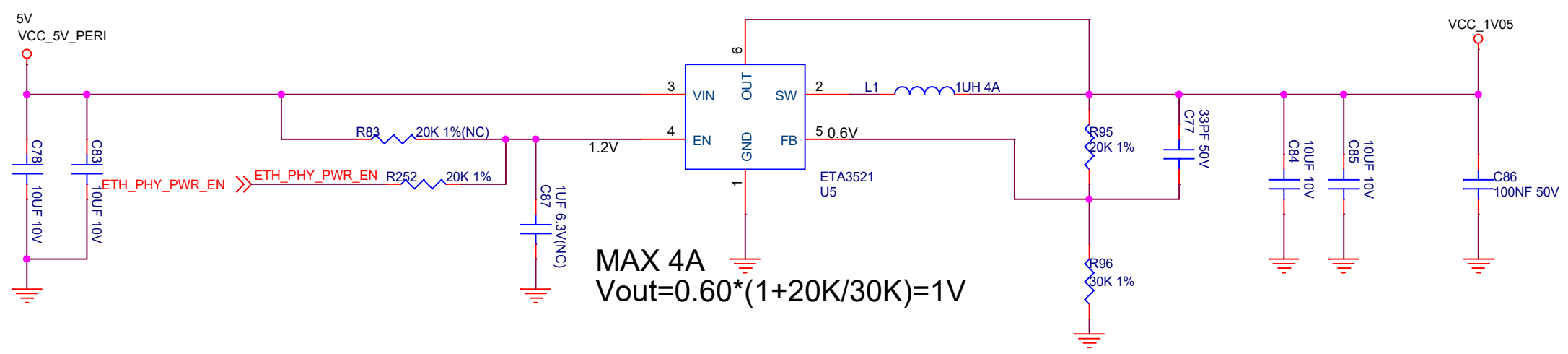

AQR0_A_P	R112	49.9R 1%	C173	100NF 25V
AQR0_A_M	R113	49.9R 1%		
AQR0_B_P	R114	49.9R 1%		
AQR0_B_M	R147	49.9R 1%	C174	100NF 25V
AQR0_C_P	R148	49.9R 1%		
AQR0_C_M	R149	49.9R 1%	C175	100NF 25V
AQR0_D_P	R155	49.9R 1%		
AQR0_D_M	R193	49.9R 1%	C206	100NF 25V



ETH_2.5G_1

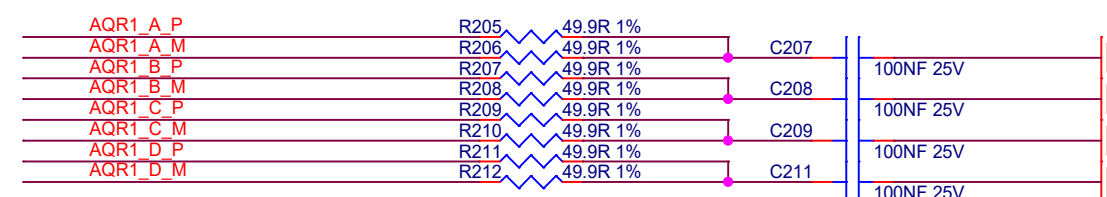
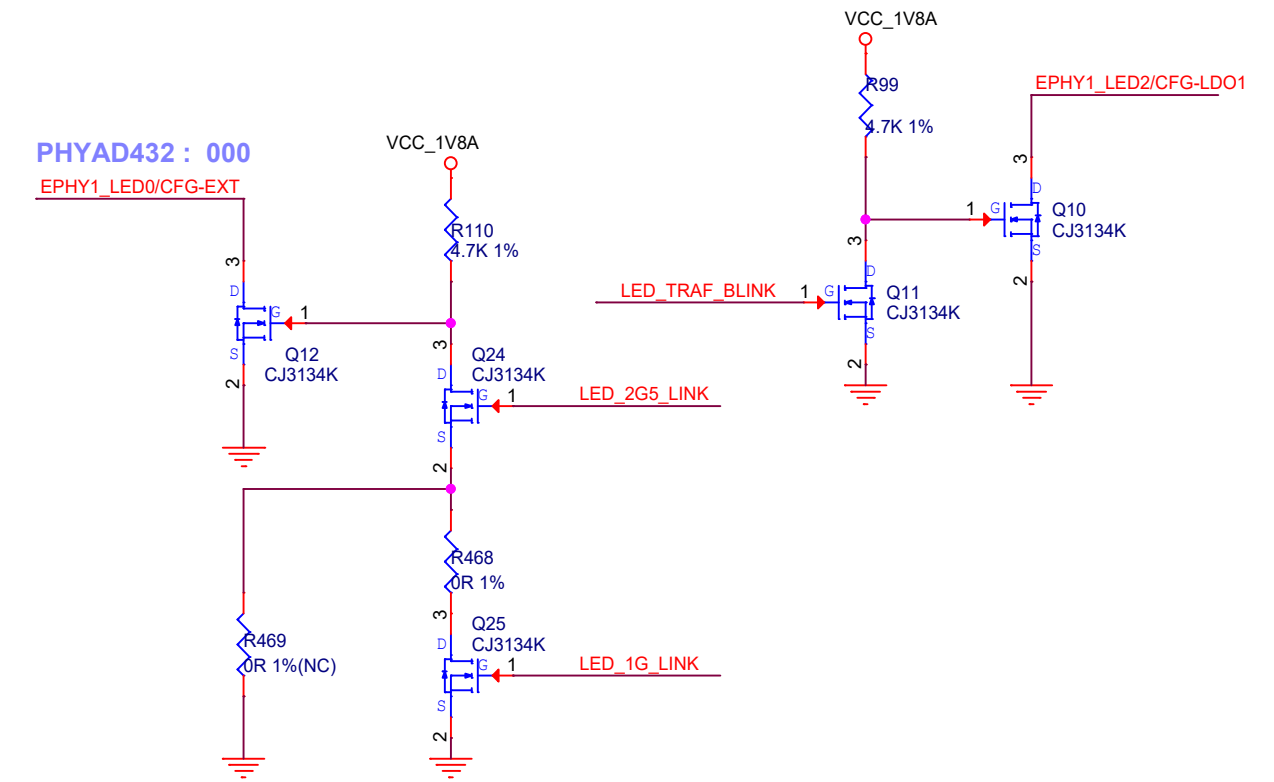
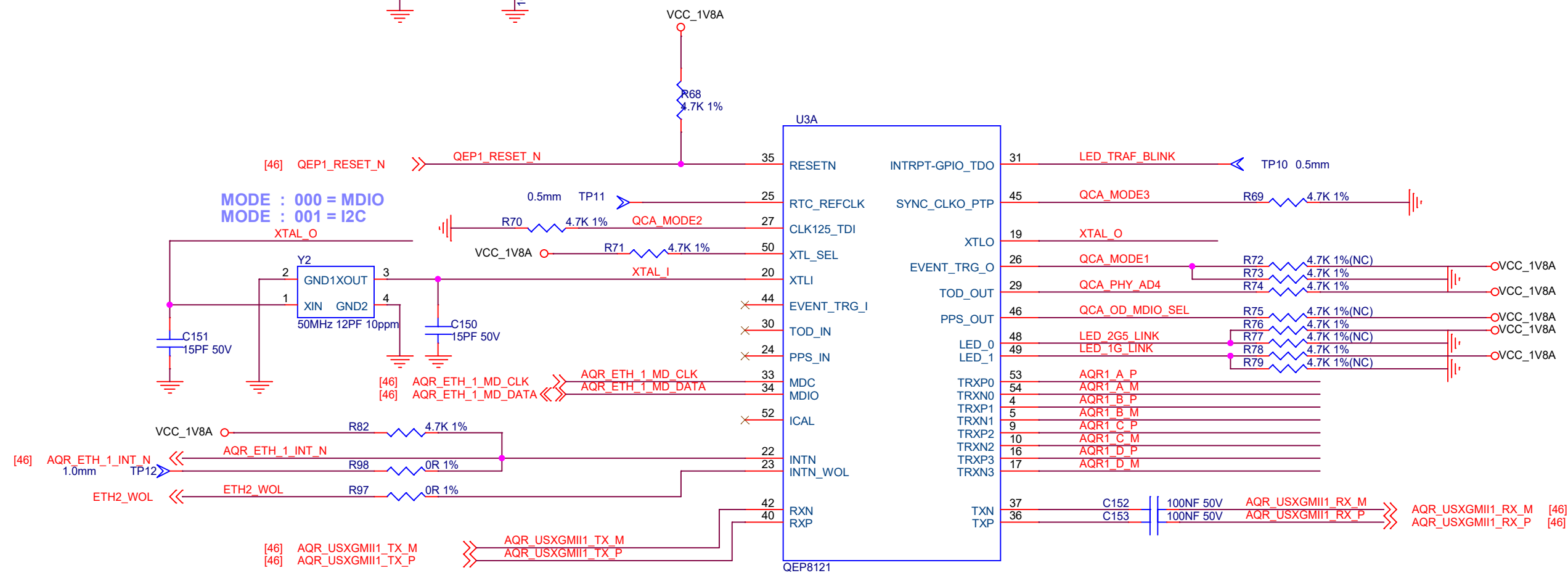
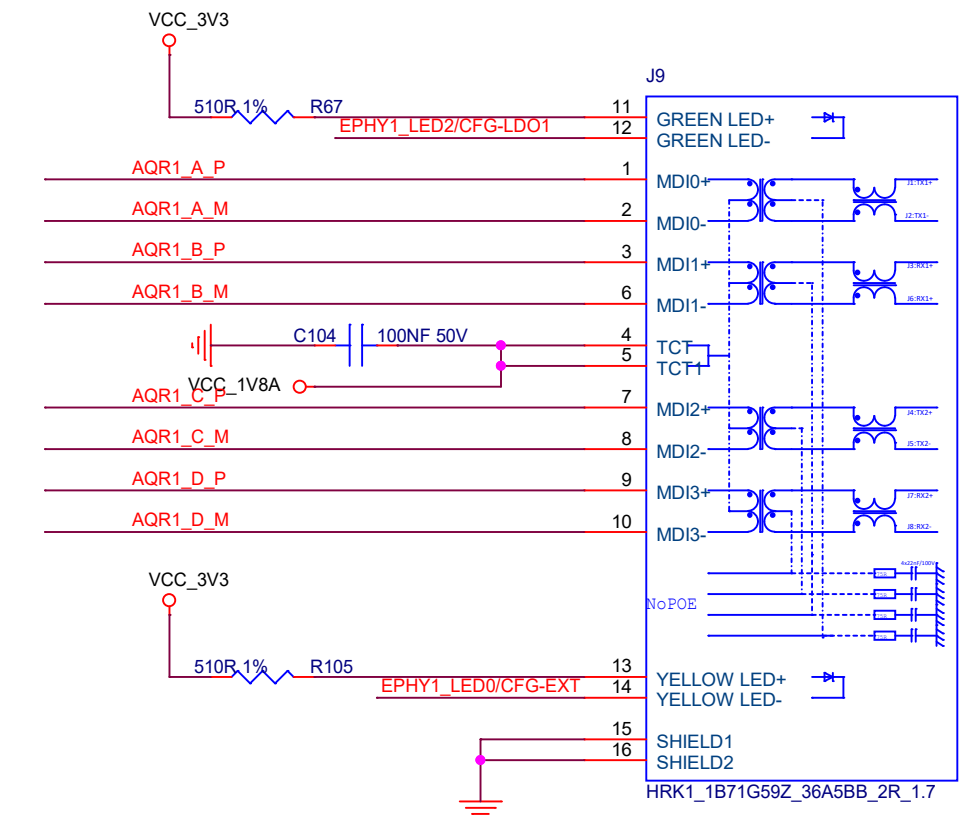
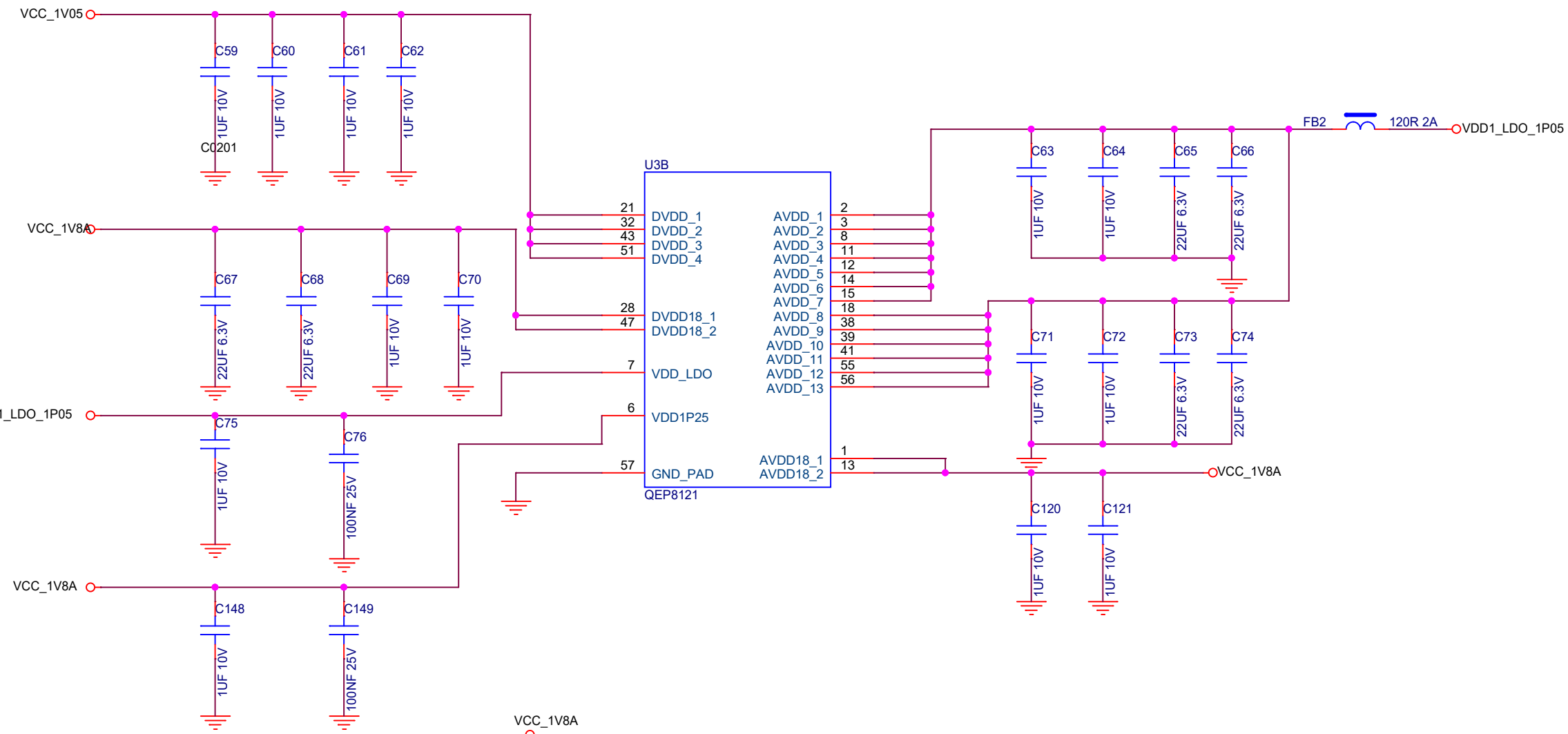

radxa

Size	Title: Radxa Dragon Q8	REV
C	Page Name: <Doc>	V1.3
Date: Monday, June 22, 2026	Sheet 48 of 50	

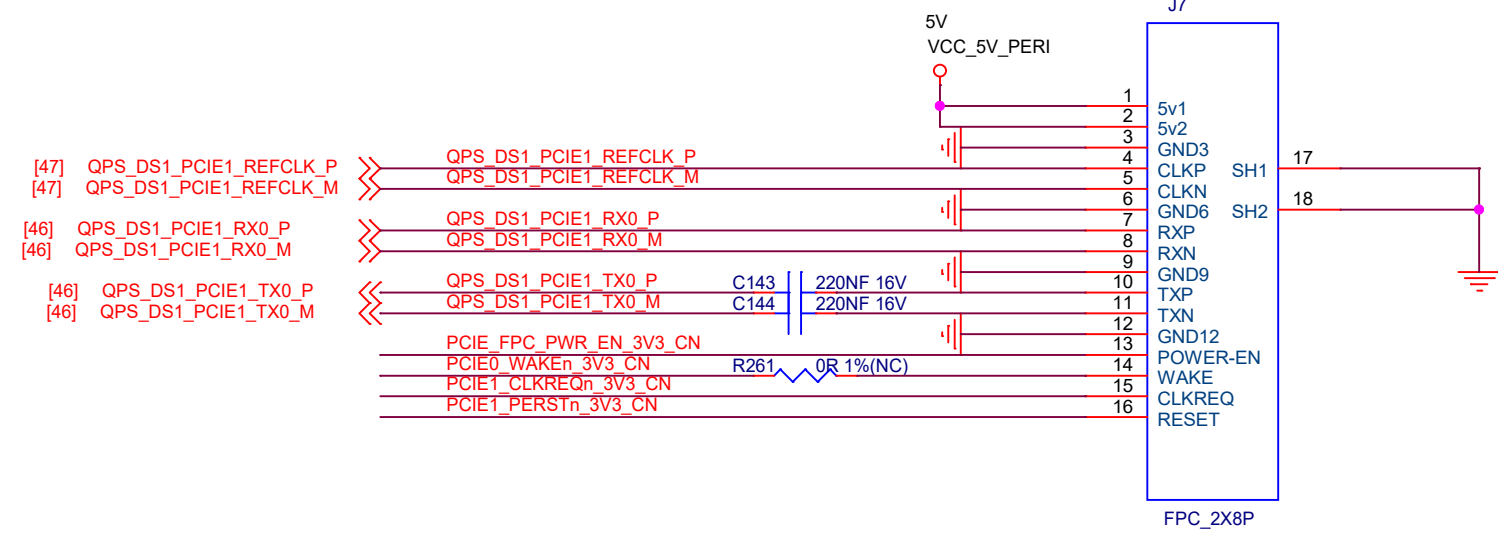
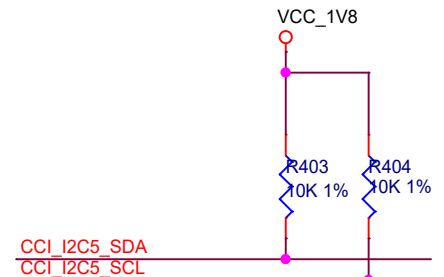
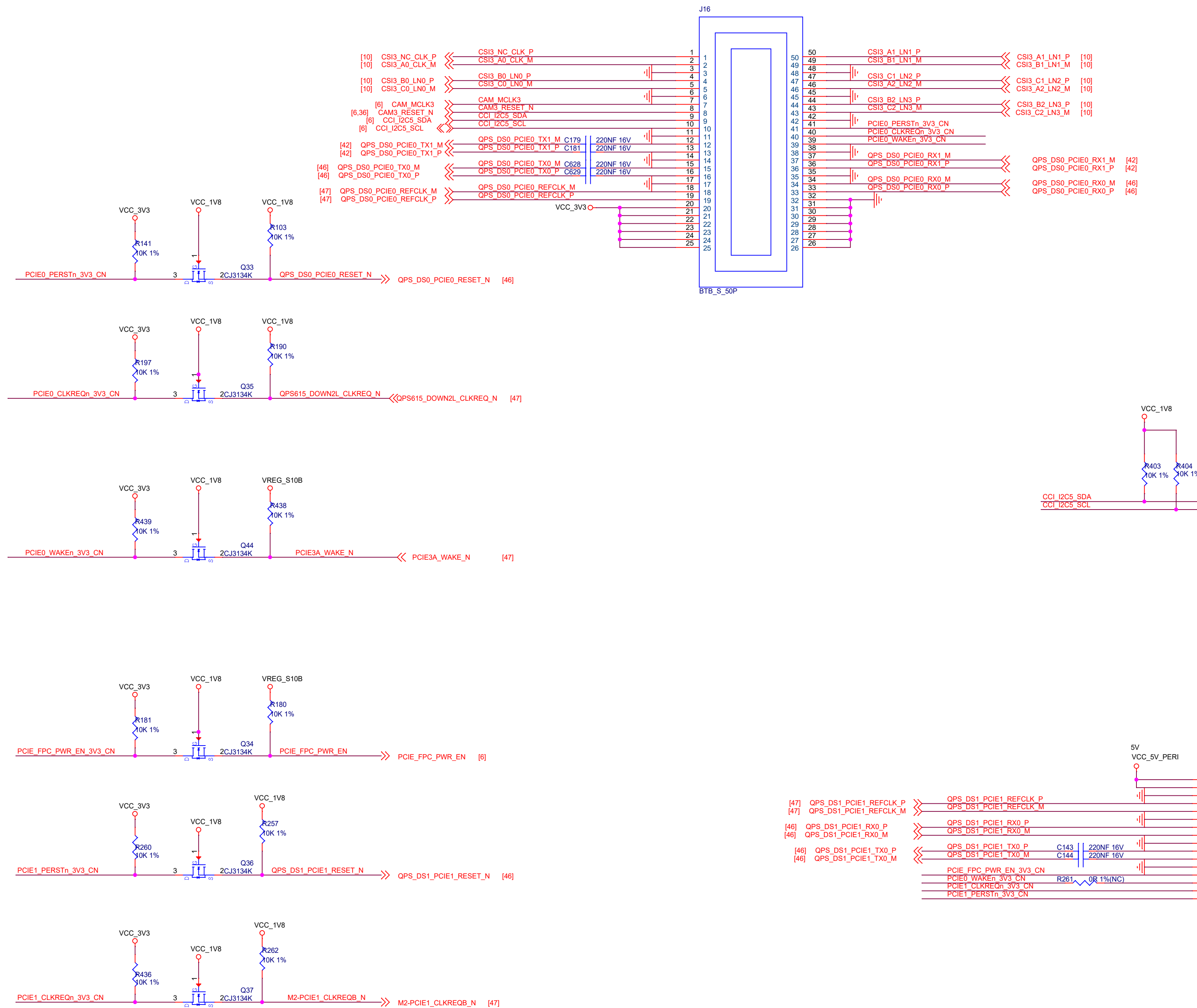

AUDIO

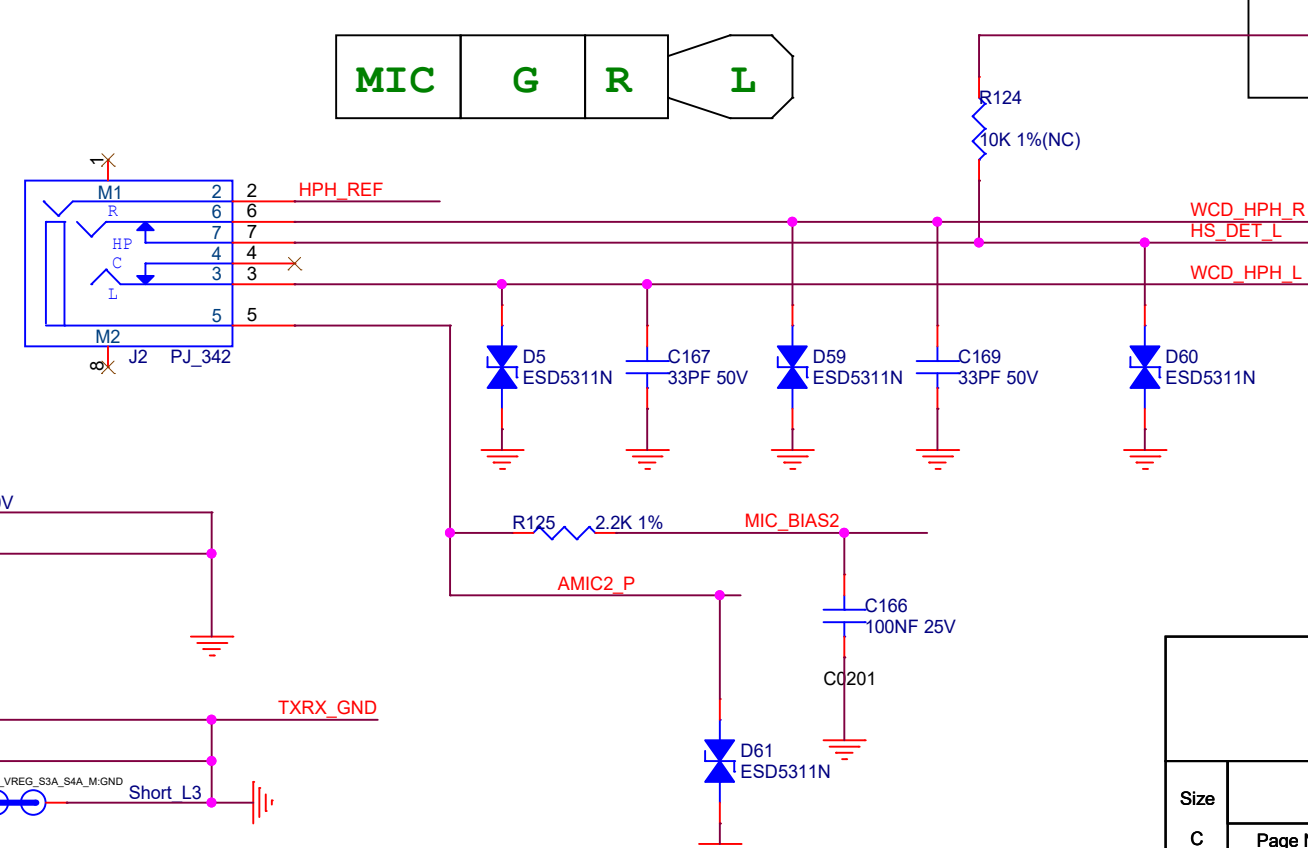
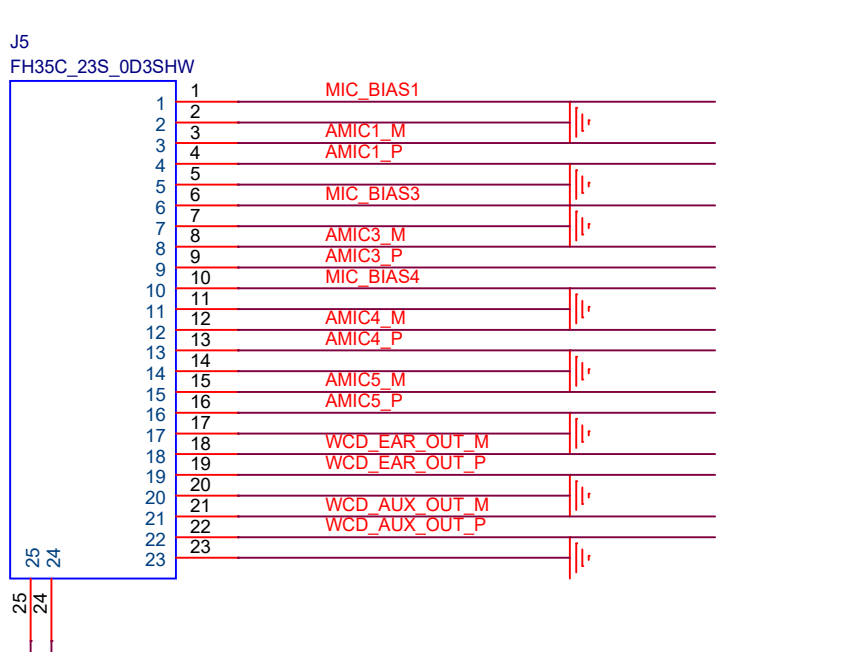
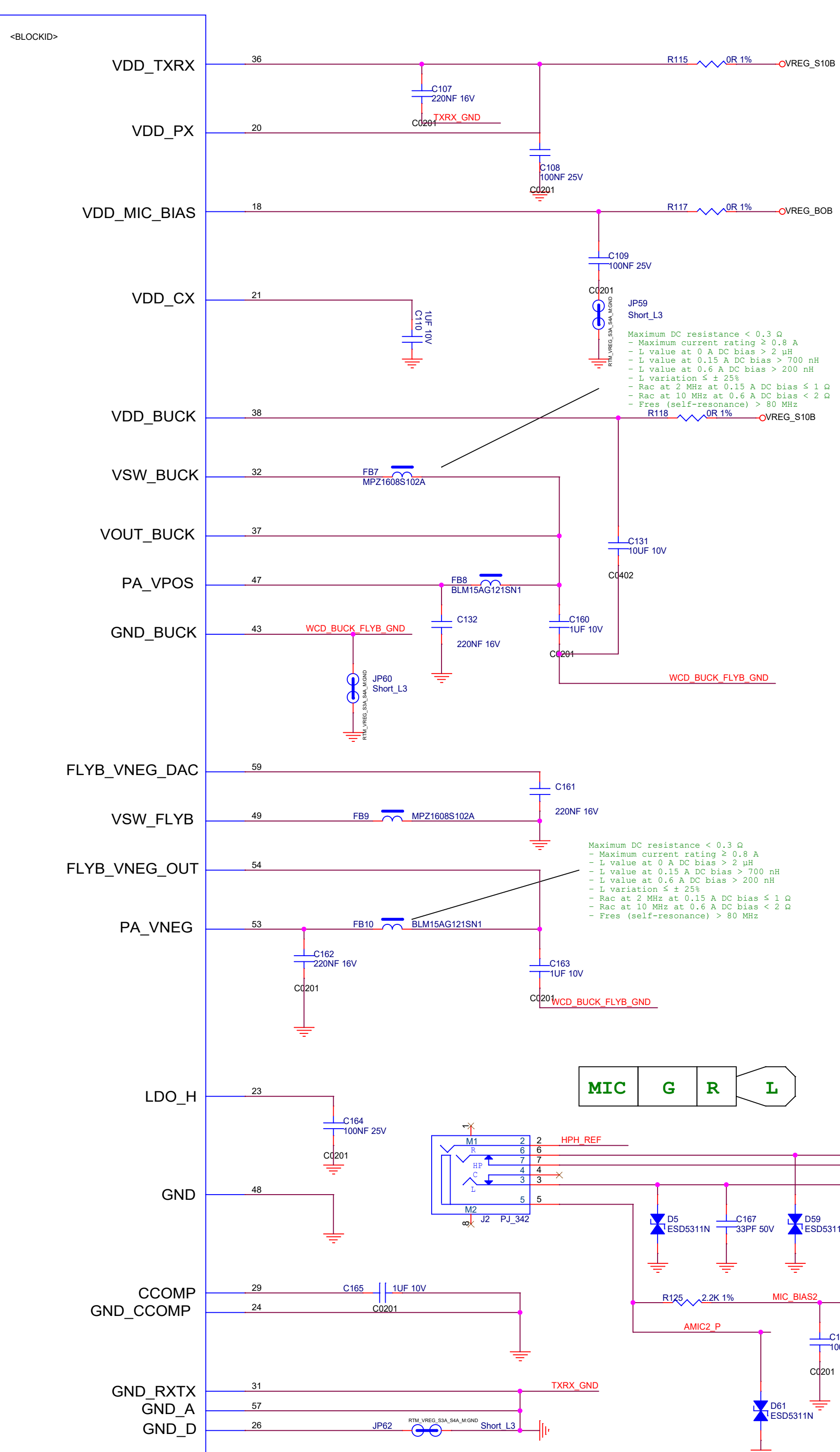

DEL