

# TEST REPORT

Report No.: BCTC2304709645-2E

---

Applicant: ROCKPI TRADING LIMITED

---

Product Name: Radxa ROCK 3 Model C

---

Model/Type reference: Radxa ROCK 3 Model C

---

Tested Date: 2023-04-07 to 2023-05-17

---

Issued Date: 2023-05-26

---

**Shenzhen BCTC Testing Co., Ltd.**



Product Name: Radxa ROCK 3 Model C  
Trademark: N/A  
Model/Type reference: Radxa ROCK 3 Model C  
Radxa ROCK 3 Model C 1GB, Radxa ROCK 3 Model C 2GB,  
Radxa ROCK 3 Model C 4GB, Radxa ROCK 3 Model C 8GB  
Prepared For: ROCKPI TRADING LIMITED  
Address: Room 11, 27 / f, Ga wah international centre, 191 Javaroad, north point, Hong Kong  
Manufacturer: ROCKPI TRADING LIMITED  
Address: Room 11, 27 / f, Ga wah international centre, 191 Javaroad, north point, Hong Kong  
Prepared By: Shenzhen BCTC Testing Co., Ltd.  
Address: 1-2/F., Building B, Pengzhou Industrial Park, No.158, Fuyuan 1st Road, Zhancheng,  
Fuhai Subdistrict, Bao'an District, Shenzhen, Guangdong, China  
Sample Received Date: 2023-04-07  
Sample tested Date: 2023-04-07 to 2023-05-17  
Issue Date: 2023-05-26  
Report No.: BCTC2304709645-2E  
Test Standards: ETSI EN 301 489-1 V2.2.3 (2019-11)  
ETSI EN 301 489-17 V3.2.4 (2020-09)  
Test Results: PASS  
Remark: This is RED EMC test report

Tested by:

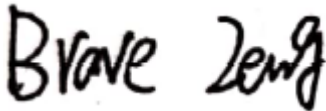

Brave Zeng/ Project Handler

Approved by:



Zero Zhou/Reviewer

The test report is effective only with both signature and specialized stamp. This result(s) shown in this report refer only to the sample(s) tested. Without written approval of Shenzhen BCTC Testing Co., Ltd, this report can't be reproduced except in full. The tested sample(s) and the sample information are provided by the client.



## Table Of Content

	Page
Test Report Declaration	
1. Version .....	5
2. Test Summary .....	6
3. Measurement Uncertainty .....	7
4. Product Information And Test Setup .....	8
4.1 Product Information.....	8
4.2 Test Setup Configuration .....	8
4.3 Support Equipment .....	9
4.4 Test Mode .....	9
5. Test Facility And Test Instrument Used.....	10
5.1 Test Facility.....	10
5.2 Test Instrument Used.....	10
6. Conducted Emissions.....	12
6.1 Block Diagram Of Test Setup.....	12
6.2 Limit .....	12
6.3 Test Procedure .....	13
6.4 Test Result.....	14
7. Radiated Emissions Test.....	17
7.1 Block Diagram Of Test Setup.....	17
7.2 Limits.....	17
7.3 Test Procedure .....	18
7.4 Test Results .....	19
8. Harmonic Current Emission(H).....	21
8.1 Block Diagram Of Test Setup.....	21
8.2 Limit .....	21
8.3 Test Procedure .....	21
8.4 Test Results .....	21
9. Voltage Fluctuations & Flicker(F) .....	22
9.1 Block Diagram Of Test Setup.....	22
9.2 Limit .....	22
9.3 Test Procedure .....	22
9.4 Test Results .....	22
10. Immunity Test Of General The Performance Criteria .....	23
11. Electrostatic Discharge (ESD).....	24
11.1 Test Specification.....	24
11.2 Block Diagram Of Test Setup.....	24
11.3 Test Procedure .....	24
11.4 Test Results .....	25
12. Continuous RF Electromagnetic Field Disturbances(RS).....	26
12.1 Test Specification.....	26
12.2 Block Diagram Of Test Setup.....	26
12.3 Test Procedure .....	27
12.4 Test Results .....	27
13. Electrical Fast Transients/Burst (EFT).....	28

BCTC  
 3C  
 PPR  
 检测

13.1	Test Specification.....	28
13.2	Block Diagram Of EUT Test Setup .....	28
13.3	Test Procedure .....	28
13.4	Test Results .....	28
14.	Surges Immunity Test .....	29
14.1	Test Specification.....	29
14.2	Block Diagram Of EUT Test Setup .....	29
14.3	Test Procedure .....	29
14.4	Test Result.....	29
15.	Continuous Induced RF Disturbances (CS) .....	30
15.1	Test Specification.....	30
15.2	Block Diagram Of EUT Test Setup .....	30
15.3	Test Procedure .....	30
15.4	Test Result.....	30
16.	Voltage Dips And Interruptions (DIPS) .....	31
16.1	Test Specification.....	31
16.2	Block Diagram Of EUT Test Setup .....	31
16.3	Test Procedure .....	31
16.4	Test Result.....	31
17.	EUT Photographs.....	32
18.	EUT Test Setup Photographs.....	36

(Note: N/A Means Not Applicable)

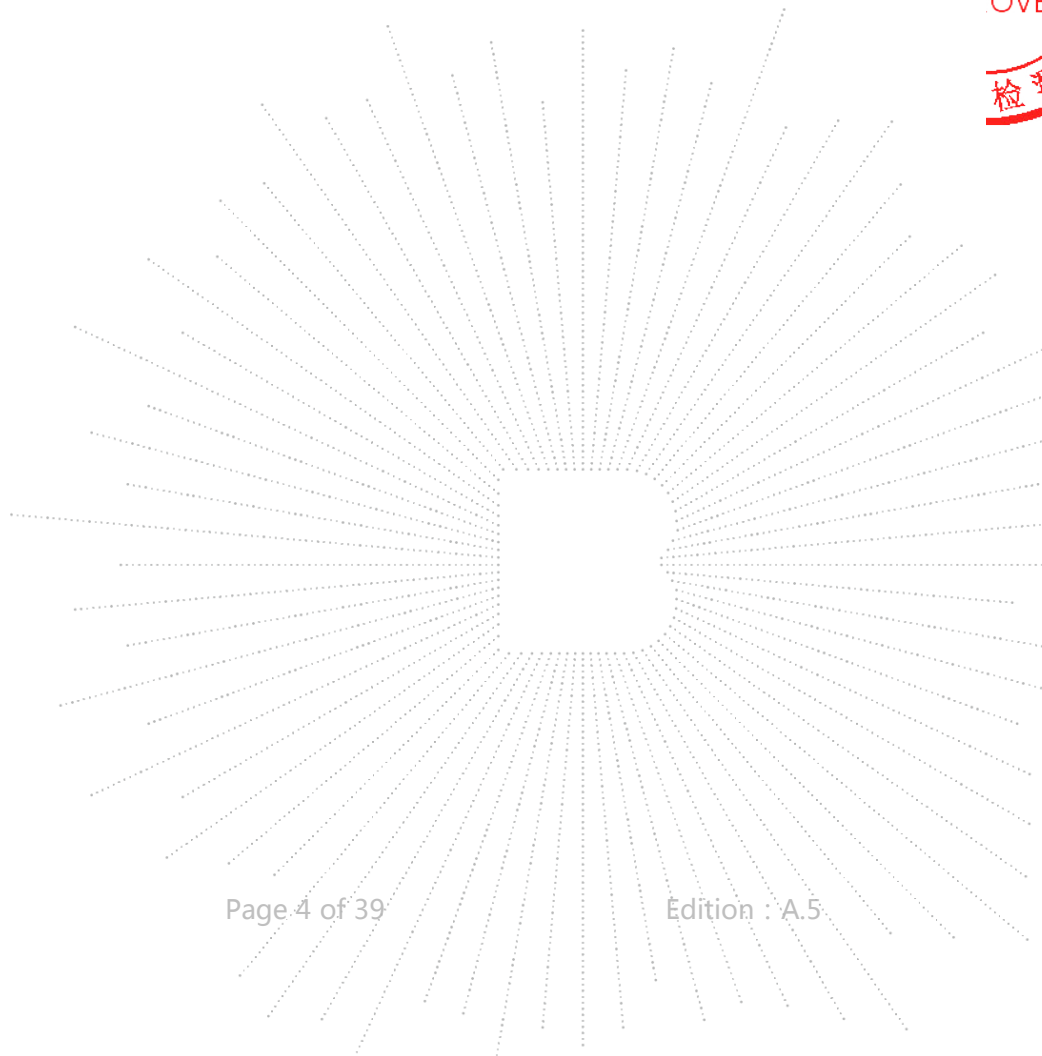

TEC  
TC  
OVB  
檢

**1. Version**

Report No.	Issue Date	Description	Approved
BCTC2304709645-2E	2023-05-26	Original	Valid

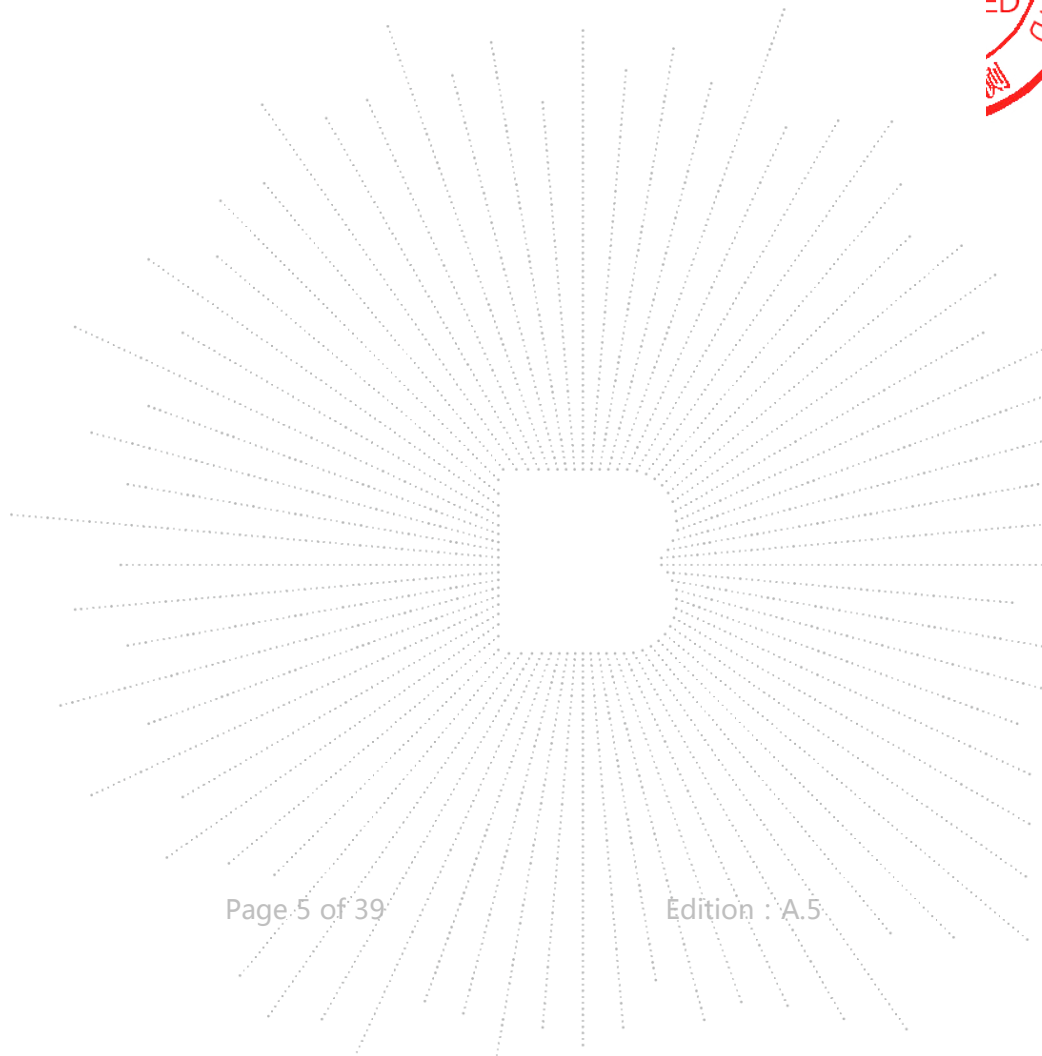

## 2. Test Summary

The Product has been tested according to the following specifications:

EMISSION		
Standard	Test Item	Test result
EN 301 489-1	Conducted emissions from the AC mains power ports	Pass
EN 301 489-1	Asymmetric mode conducted emissions	Pass
EN 301 489-1	Conducted differential voltage emissions	N/A <sup>2</sup>
EN 301 489-1	Radiated emissions	Pass
EN 301 489-1	Harmonic current emission(H)	N/A <sup>3</sup>
EN 301 489-1	Voltage fluctuations & flicker(F)	N/A <sup>4</sup>

IMMUNITY		
Standard	Test Item	Test result
EN 301 489-1	Electrostatic discharge (ESD)	Pass
EN 301 489-1	Continuous RF electromagnetic field disturbances(RS)	Pass
EN 301 489-1	Electrical fast transients/burst (EFT)	N/A <sup>4</sup>
EN 301 489-1	Surges	N/A <sup>4</sup>
EN 301 489-1	Radio frequency, common mode	N/A <sup>4</sup>
EN 301 489-1	Voltage dips and interruptions (DIPS)	N/A <sup>4</sup>

Remark:

1. Applicable to ports listed above and intended to connect to cables longer than 3 m.
2. The Product has no antenna port.
3. The Product belongs to Class A, and its power is less than 75W, so it deems to fulfil this standard without testing.
4. The EUT is powered by the DC only, the test item is not applicable.

### 3. Measurement Uncertainty

Where relevant, the following measurement uncertainty levels have been estimated for tests performed on the Product as specified in CISPR 16-4-2. This uncertainty represents an expanded uncertainty expressed at approximately the 95% confidence level using a coverage factor of  $k=2$ .

Test item	Value (dB)
Conducted Emission (150kHz-30MHz)	3.20
Radiated Emission(30MHz~1GHz)	4.80
Radiated Emission(1GHz~6GHz)	4.90



## 4. Product Information And Test Setup

### 4.1 Product Information

Model/Type reference:	Radxa ROCK 3 Model C Radxa ROCK 3 Model C 1GB, Radxa ROCK 3 Model C 2GB, Radxa ROCK 3 Model C 4GB, Radxa ROCK 3 Model C 8GB
Model differences:	All the model are the same circuit and RF module, except model names.
Bluetooth version:	5.0
Hardware Version:	V1.32
Software Version:	V1.0
Operation Frequency:	Bluetooth(EDR+BLE): 2402-2480MHz WIFI(2.4GHz): IEEE 802.11b/g/n HT20: 2412-2472MHz WIFI(5.1GHz): IEEE 802.11a/n/ac HT20:5180MHz-5240MHz IEEE 802.11n/ac HT40:5190MHz-5230MHz IEEE 802.11ac HT80:5210MHz
Max. RF output power:	Bluetooth(EDR): 0.97 dBm Bluetooth(BLE): 2.95 dBm WIFI(2.4GHz): 12.61 dBm WIFI(5.1GHz): 2.5 dBm
Type of Modulation:	Bluetooth(EDR): GFSK, $\pi/4$ DQPSK, 8DPSK Bluetooth(BLE):GFSK WIFI(2.4GHz): DSSS, OFDM WIFI(5.1GHz): OFDM-BPSK, QPSK, 16QAM, 64QAM, 256QAM
Antenna installation:	Internal antenna
Antenna Gain:	Bluetooth(EDR+BLE)+WIFI(2.4GHz): 1.5 dBi WIFI(5.1GHz): 2.3 dBi
Ratings:	DC 5V from adapter

#### Cable of Product

No.	Cable Type	Quantity	Provider	Length (m)	Shielded	Note
1	--	--	Applicant	---	Yes/No	With a ferrite ring in mid Detachable
2	--	--	BCTC	--	Yes/No	--

### 4.2 Test Setup Configuration

See test photographs attached in EUT TEST SETUP PHOTOGRAPHS for the actual connections between Product and support equipment.



### 4.3 Support Equipment

No.	Device Type	Brand	Model	Series No.	Note
1.	Adapter	---	BCTC001	---	auxiliary

**Notes:**

1. All the equipment/cables were placed in the worst-case configuration to maximize the emission during the test.
2. Grounding was established in accordance with the manufacturer's requirements and conditions for the intended use.

### 4.4 Test Mode

Test item	Test Mode	Test Voltage
Conducted emissions at AC Port QP/AV <input type="checkbox"/> Class A <input checked="" type="checkbox"/> Class B	USB+HDMI+earphone+ Adapter+LAN	AC 230V/50Hz
Conducted emissions at wired network Port QP/AV <input type="checkbox"/> Class A <input checked="" type="checkbox"/> Class B	USB+HDMI+earphone+ Adapter+LAN	AC 230V/50Hz
Radiated emissions(30MHz-6GHz) <input type="checkbox"/> Class A <input checked="" type="checkbox"/> Class B	USB+HDMI+earphone+ Adapter+LAN	AC 230V/50Hz
Electrostatic discharge (ESD) <input checked="" type="checkbox"/> HCP & VCP: ±4Kv <input checked="" type="checkbox"/> Air Discharge: ±8kV <input checked="" type="checkbox"/> Contact Discharge: ±4kV	USB+HDMI+earphone+ Adapter+LAN	AC 230V/50Hz
Continuous RF electromagnetic field disturbances(RS) 80MHz-6000MHz,, 3V/m,80% Front, Rear, Left, Right H/V	USB+HDMI+earphone+ Adapter+LAN	AC 230V/50Hz

BCTC  
 3C  
 PPR  
 检测

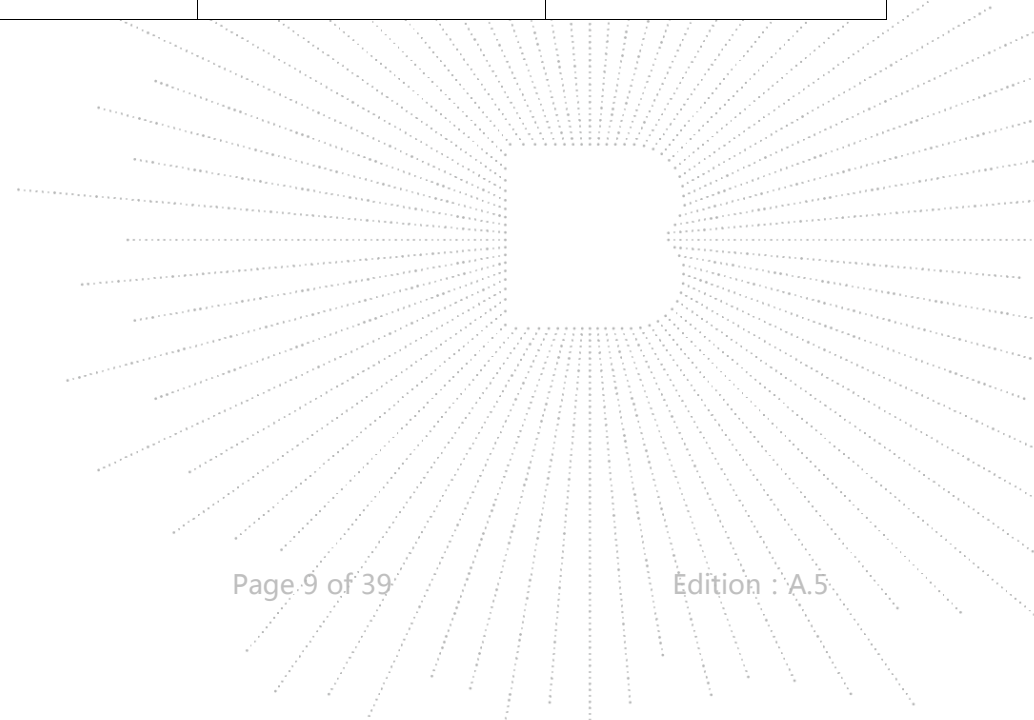

## 5. Test Facility And Test Instrument Used

### 5.1 Test Facility

All measurement facilities used to collect the measurement data are located at Shenzhen BCTC Testing Co., Ltd. Address: 1-2/F., Building B, Pengzhou Industrial Park, No.158, Fuyuan 1st Road, Zhancheng, Fuhai Subdistrict, Bao'an District, Shenzhen, Guangdong, China. The site and apparatus are constructed in conformance with the requirements of ANSI C63.4 and CISPR 16-1-1 other equivalent standards.

### 5.2 Test Instrument Used

Conducted Emissions Test					
Equipment	Manufacturer	Model#	Serial#	Last Cal.	Next Cal.
Receiver	R&S	ESR3	102075	May 24, 2022	May 23, 2023
LISN	R&S	ENV216	101375	May 24, 2022	May 23, 2023
ISN	HPX	ISN T800	S1509001	May 24, 2022	May 23, 2023
Software	Frad	EZ-EMC	EMC-CON 3A1	\	\
Attenuator	\	10dB DC-6GHz	1650	May 24, 2022	May 23, 2023

Radiated Emissions Test (966 Chamber#02)					
Equipment	Manufacturer	Model#	Serial#	Last Cal.	Next Cal.
966 chamber	SKET	966 Room	966	Nov. 02. 2021	Nov. 01.2024
Receiver	R&S	ESR3	102075	May 24, 2022	May 23, 2023
Receiver	R&S	ESR17	100010	Nov. 08. 2022	Nov. 07.2023
TRILOG Broadband Antenna	Schwarzbeck	VULB9168	1323	Mar. 06, 2022	Mar. 05, 2024
Amplifier	SKET	LNPA-30M01 G-30	SK202108200 4	Nov. 08. 2022	Nov. 07.2023
Software	SKET	EZ-EMC	FA-03A1	\	\
Horn Antenna	schwarzbeck	BBHA9120D	1541	Jun. 06, 2022	Jun. 06, 2023
Amplifier	SKET	LAPA_01G18 G-45dB	\	May 24, 2022	May 23, 2023

Electrostatic Discharge Test					
Equipment	Manufacturer	Model#	Serial#	Last Cal.	Next Cal.
ESD Tester	KIKUSUI	KES4201A	UH002321	May 26, 2022	May 25, 2023

Continuous RF Electromagnetic Field Disturbances Test					
Equipment	Manufacturer	Model#	Serial#	Last Cal.	Next Cal.
Power meter	Keysight	E4419	A00065	May 24, 2022	May 23, 2023
Power sensor	Keysight	E9300A	US39211659	May 24, 2022	May 23, 2023
Power sensor	Keysight	E9300A	US39211305	May 24, 2022	May 23, 2023
Amplifier	SKET	HAP_801000 -250W	21201805013	May 24, 2022	May 23, 2023
Amplifier	SKET	HAP_0103-7 5W	21201805014	May 24, 2022	May 23, 2023
Amplifier	SKET	HAP_0306-5 0W	21201805015	May 24, 2022	May 23, 2023
Stacked double Log.-Per. Antenna	Schwarzbeck	STLP 9129	00077	\	\
Field Probe	Narda	EP-601	611WX80256	May 30, 2022	May 29, 2023
Signal Generator	Agilent	N5181A	MY50143748	May 24, 2022	May 23, 2023
Software	SKET	EMC-S	1.2.0.18	\	\

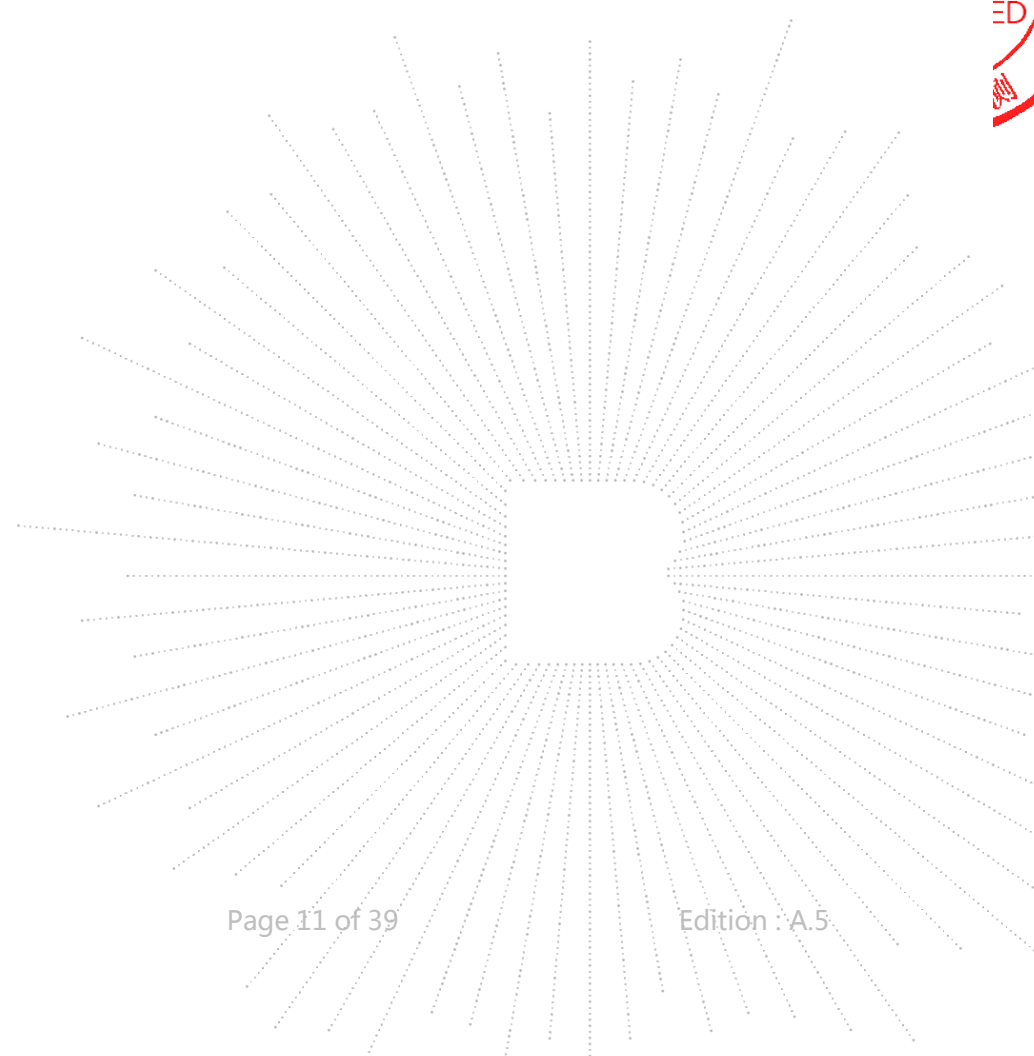

## 6. Conducted Emissions

### 6.1 Block Diagram Of Test Setup

For mains ports:

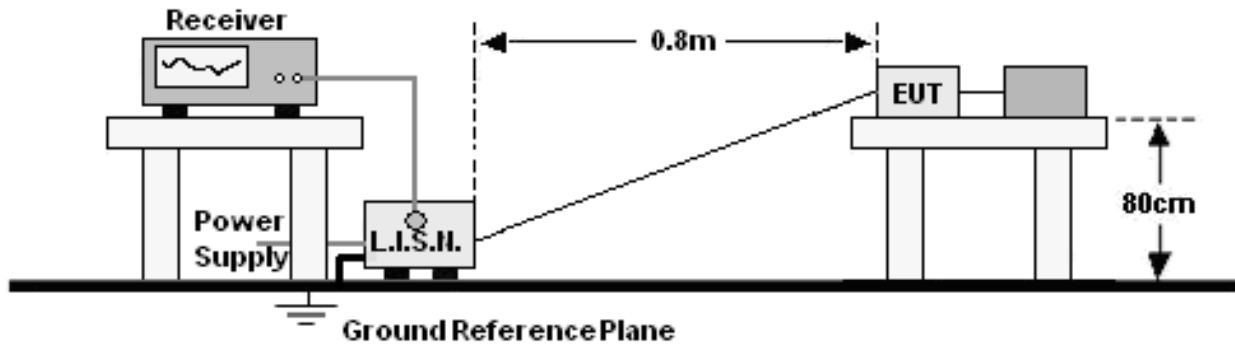

For asymmetric mode ports:

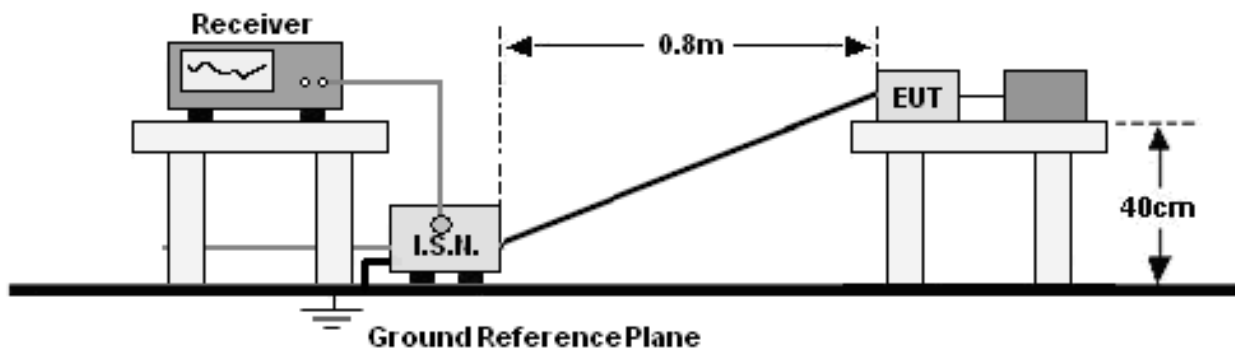

### 6.2 Limit

#### Limits for Conducted emissions at the mains ports of Class B MME

Frequency range (MHz)	Limits / dB( $\mu$ V)	
	Quasi-peak	Average
0,15 to 0,50	66 to 56*	56 to 46*
0,50 to 5	56	46
5 to 30	60	50

Notes: 1. \*Decreasing linearly with logarithm of frequency.  
2. The lower limit shall apply at the transition frequencies.

#### Limits for asymmetric mode conducted emissions of Class B MME

Frequency range (MHz)	Voltage Limits / dB( $\mu$ V)		Current Limits / dB( $\mu$ A)	
	Quasi-peak	Average	Quasi-peak	Average
0,15 to 0,50	84-74	74-64	40-30	30-20
0,50 to 30	74	64	30	20

Notes: \*Decreasing linearly with logarithm of frequency.

### 6.3 Test Procedure

**For mains ports:**

- a. The Product was placed on a nonconductive table 0.8 m above the horizontal ground reference plane, and 0.4 m from the vertical ground reference plane, and connected to the main through Line Impedance Stability Network (L.I.S.N).
- b. The RBW of the receiver was set at 9 kHz in 150 kHz ~ 30MHz with Peak and AVG detector in Max Hold mode. Run the receiver's pre-scan to record the maximum disturbance generated from Product in all power lines in the full band.
- c. For each frequency whose maximum record was higher or close to limit, measure its QP and AVG values and record.

**For asymmetric mode ports:**

- a. The Product was placed on a non-conductive table 0.8 m above the horizontal ground reference plane, and 0.4 m from the vertical ground reference plane, and connected to the associated port through current probe.
- b. The RBW of the receiver was set at 9 kHz in 150 kHz ~ 30MHz with Peak and AVG detector in Max Hold mode. Run the receiver's pre-scan to record the maximum disturbance generated from Product in all power lines in the full band.
- c. For each frequency whose maximum record was higher or close to limit, measure its QP and AVG values and record.

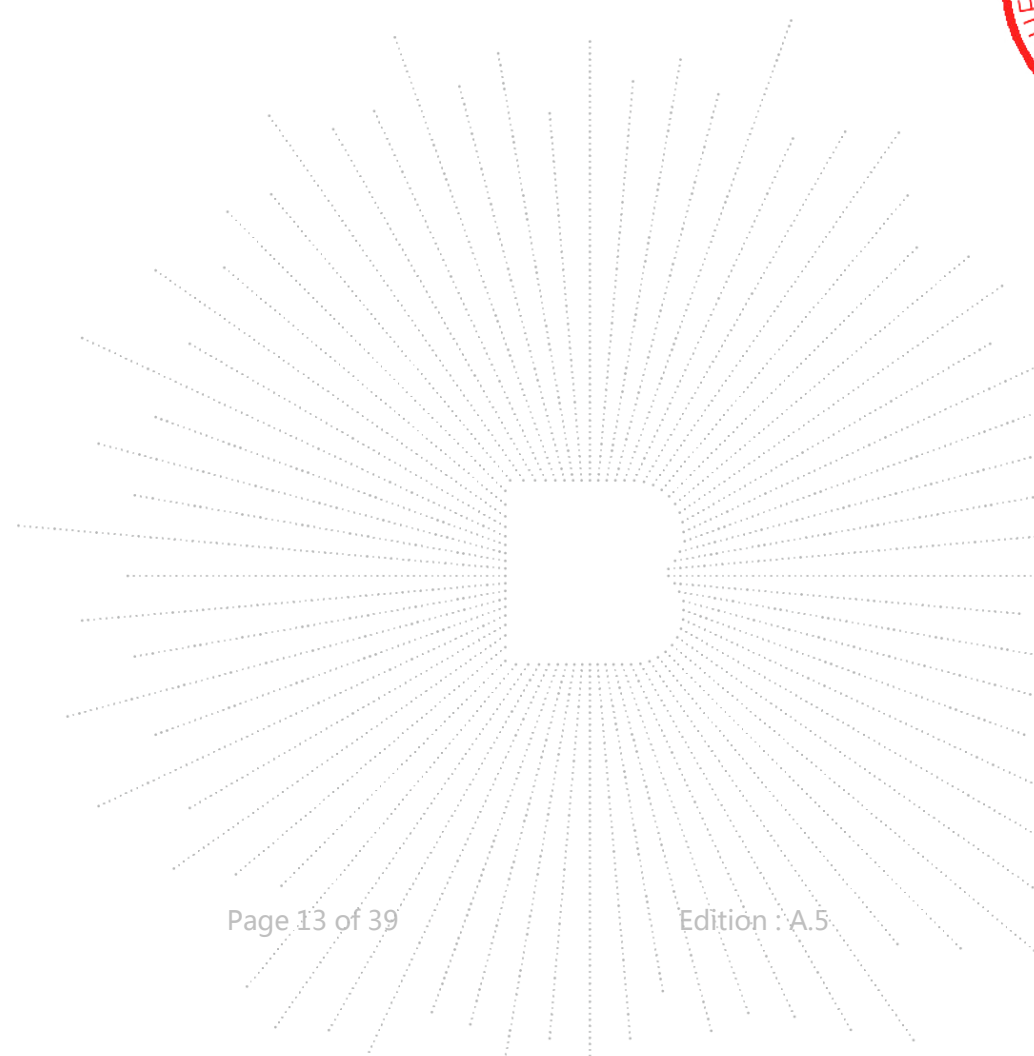

### 6.4 Test Result

Temperature:	26 °C	Relative Humidity:	54%
Pressure:	101KPa	Phase :	L
Test Mode:	USB+HDMI+earphone+Adapter+LAN	Remark:	N/A

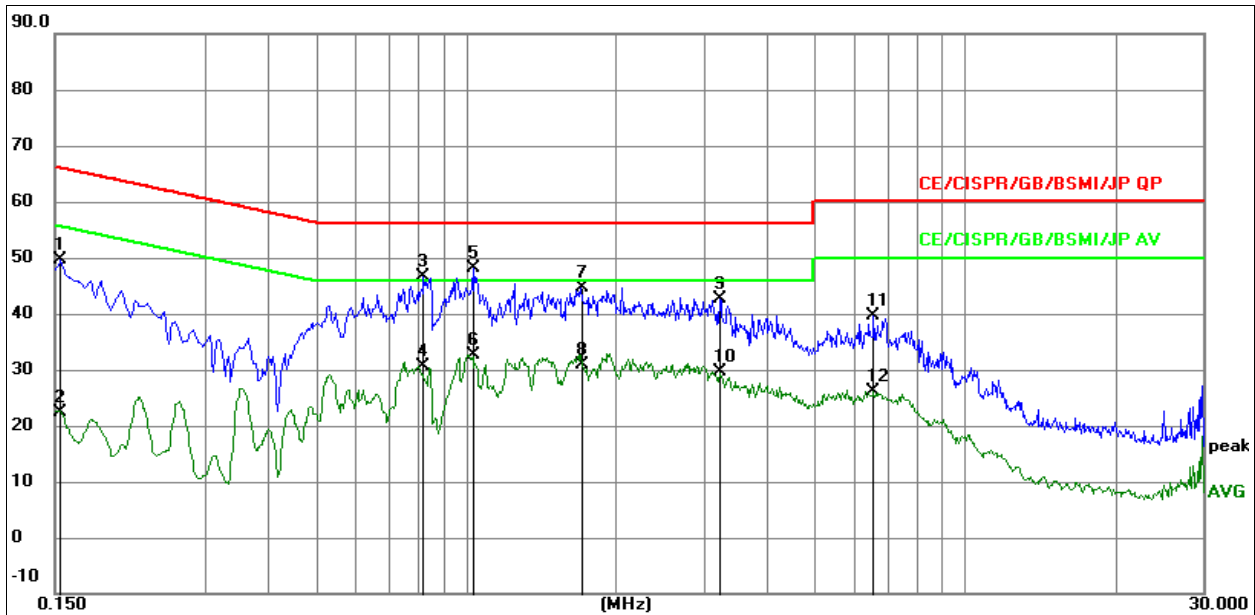

Remark:

1. All readings are Quasi-Peak and Average values.
2. Factor = Insertion Loss + Cable Loss.
3. Measurement=Reading Level+ Correct Factor
4. Over= Measurement-Limit

No.	Mk.	Freq. MHz	Reading Level	Correct Factor dB	Measure- ment dBuV	Limit dBuV	Over dB	Detector
1		0.1539	29.83	19.68	49.51	65.79	-16.28	QP
2		0.1539	2.72	19.68	22.40	55.79	-33.39	AVG
3		0.8217	26.88	19.75	46.63	56.00	-9.37	QP
4		0.8217	10.76	19.75	30.51	46.00	-15.49	AVG
5	*	1.0320	28.39	19.76	48.15	56.00	-7.85	QP
6		1.0320	12.86	19.76	32.62	46.00	-13.38	AVG
7		1.6981	24.82	19.84	44.66	56.00	-11.34	QP
8		1.6981	11.14	19.84	30.98	46.00	-15.02	AVG
9		3.2239	22.73	20.01	42.74	56.00	-13.26	QP
10		3.2239	9.69	20.01	29.70	46.00	-16.30	AVG
11		6.5573	19.52	20.17	39.69	60.00	-20.31	QP
12		6.5573	5.86	20.17	26.03	50.00	-23.97	AVG

Temperature:	26 °C	Relative Humidity:	54%
Pressure:	101KPa	Phase :	N
Test Mode:	USB+HDMI+earphone+Adapter+LAN	Remark:	N/A

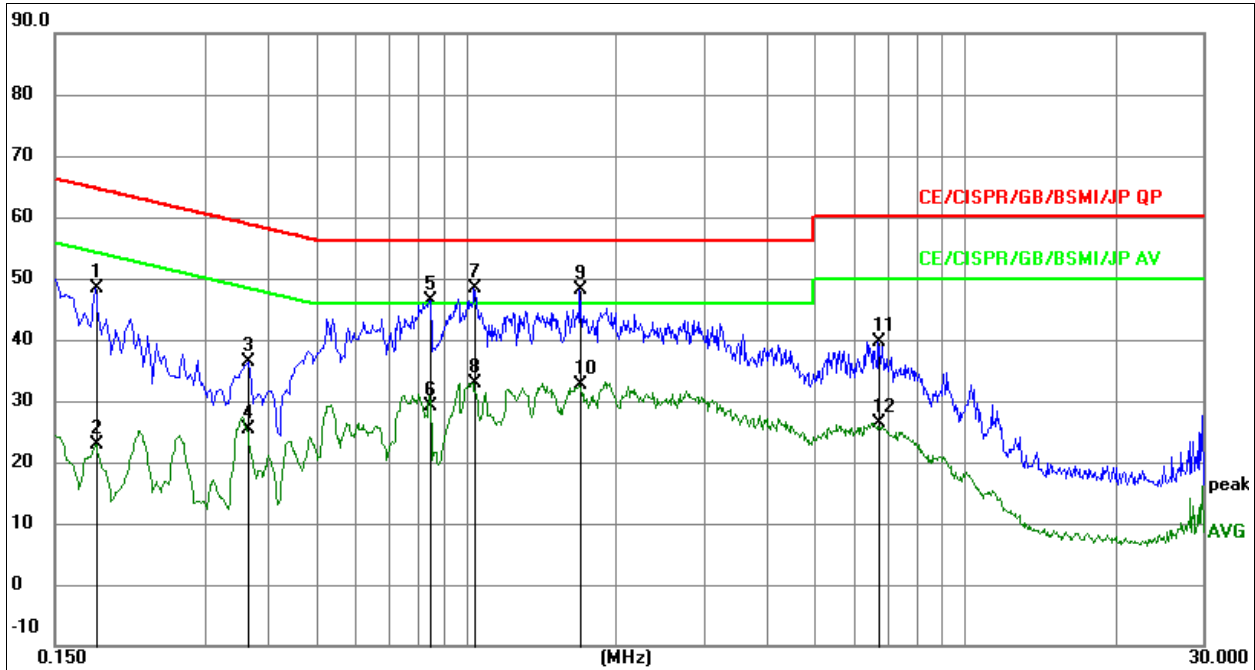

**Remark:**

1. All readings are Quasi-Peak and Average values.
2. Factor = Insertion Loss + Cable Loss.
3. Measurement=Reading Level+ Correct Factor
4. Over= Measurement-Limit

No.	Mk.	Freq. MHz	Reading Level	Correct Factor dB	Measure- ment dBuV	Limit dBuV	Over dB	Detector
1		0.1815	28.52	19.75	48.27	64.42	-16.15	QP
2		0.1815	3.02	19.75	22.77	54.42	-31.65	AVG
3		0.3660	16.66	19.76	36.42	58.59	-22.17	QP
4		0.3660	5.63	19.76	25.39	48.59	-23.20	AVG
5		0.8475	26.62	19.75	46.37	56.00	-9.63	QP
6		0.8475	9.27	19.75	29.02	46.00	-16.98	AVG
7	*	1.0410	28.56	19.76	48.32	56.00	-7.68	QP
8		1.0410	13.22	19.76	32.98	46.00	-13.02	AVG
9		1.6980	28.30	19.84	48.14	56.00	-7.86	QP
10		1.6980	12.73	19.84	32.57	46.00	-13.43	AVG
11		6.7290	19.51	20.17	39.68	60.00	-20.32	QP
12		6.7290	6.15	20.17	26.32	50.00	-23.68	AVG

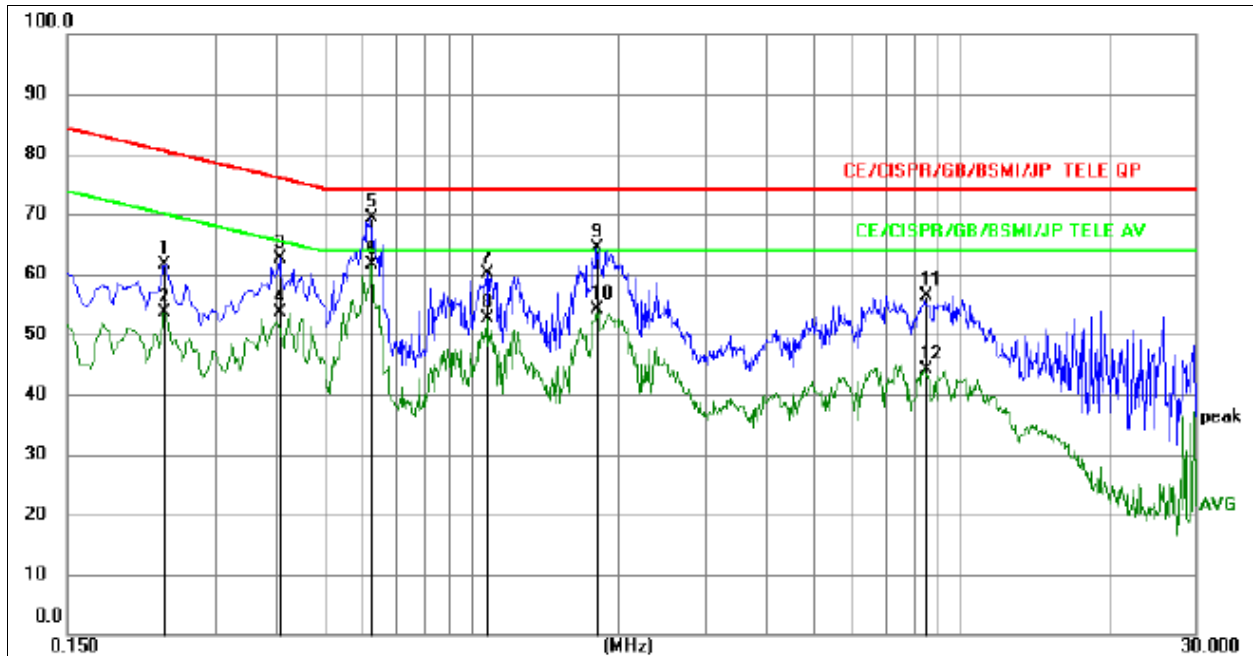

Temperature:	26 °C	Relative Humidity:	54%
Pressure:	101KPa	Phase :	TELE
Test Mode:	USB+HDMI+earphone+Adapter+LAN	Remark:	N/A

**Remark:**

1. All readings are Quasi-Peak and Average values.
2. Factor = Insertion Loss + Cable Loss.
3. Measurement=Reading Level+ Correct Factor
4. Over= Measurement-Limit

No.	Mk.	Freq. MHz	Reading Level	Correct Factor dB	Measure- ment dBuV	Limit dBuV	Over dB	Detector
1		0.2354	42.06	19.53	61.59	80.26	-18.67	QP
2		0.2354	34.03	19.53	53.56	70.26	-16.70	AVG
3		0.4063	43.01	19.65	62.66	75.72	-13.06	QP
4		0.4063	34.10	19.65	53.75	65.72	-11.97	AVG
5		0.6270	49.58	19.73	69.31	74.00	-4.69	QP
6	*	0.6270	41.87	19.73	61.60	64.00	-2.40	AVG
7		1.0768	40.28	19.86	60.14	74.00	-13.86	QP
8		1.0768	32.83	19.86	52.69	64.00	-11.31	AVG
9		1.8060	44.53	19.88	64.41	74.00	-9.59	QP
10		1.8060	34.13	19.88	54.01	64.00	-9.99	AVG
11		8.4659	36.10	20.28	56.38	74.00	-17.62	QP
12		8.4659	23.81	20.28	44.09	64.00	-19.91	AVG



## 7. Radiated Emissions Test

### 7.1 Block Diagram Of Test Setup

30MHz ~ 1GHz:

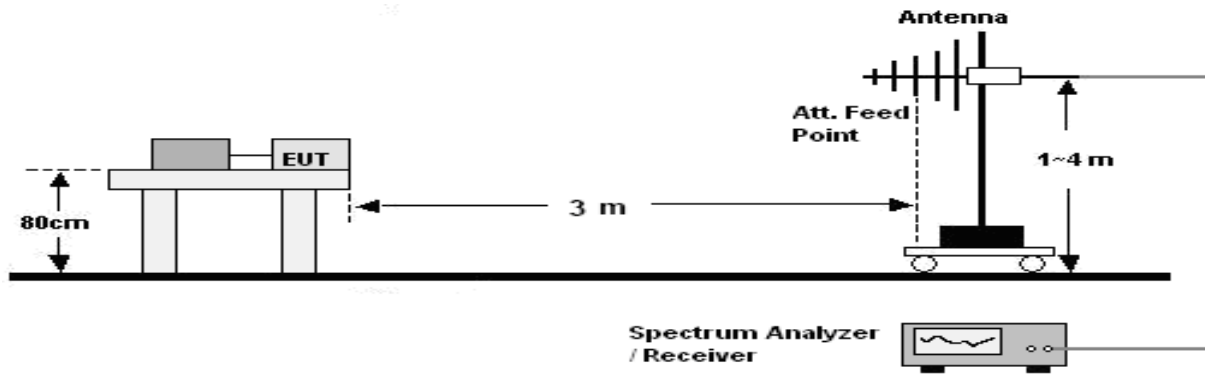

Above 1GHz:

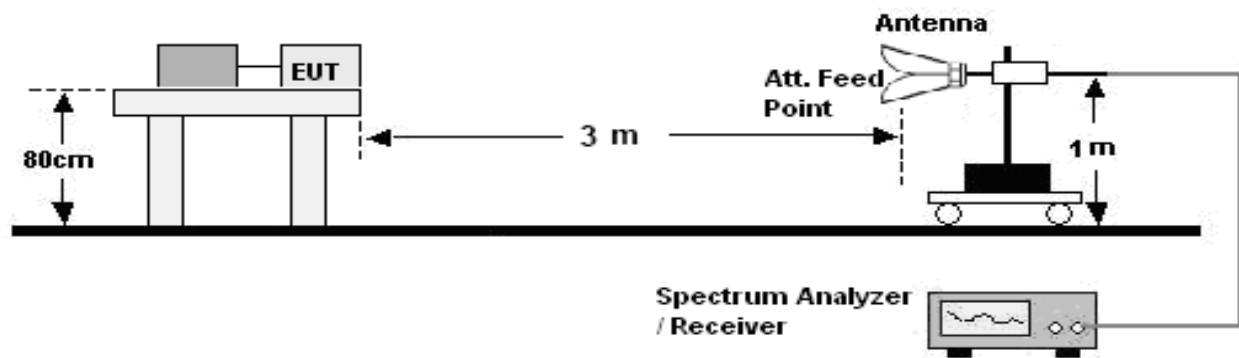

### 7.2 Limits

Limits for radiated disturbance of Class B MME

Frequency (MHz)	Quasi-peak limits at 3m Db(Mv/m)	
30-230	40	
230-1000	47	
Frequency (GHz)	limit above 1G at 3m Db(Mv/m)	
	Average	peak
1-3	50	70
3-6	54	74

**Note:** The lower limit shall apply at the transition frequencies.

### 7.3 Test Procedure

**30MHz ~ 1GHz:**

- a. The Product was placed on the nonconductive turntable 0.8 above the ground in a semi anechoic chamber.
- b. Set the spectrum analyzer/receiver in Peak detector, Max Hold mode, and 120 kHz RBW. Record the maximum field strength of all the pre-scan process in the full band when the antenna is varied between 1~4 m in both horizontal and vertical, and the turntable is rotated from 0 to 360 degrees.
- c. For each frequency whose maximum record was higher or close to limit, measure its QP value: vary the antenna's height and rotate the turntable from 0 to 360 degrees to find the height and degree where Product radiated the maximum emission, then set the test frequency analyzer/receiver to QP Detector and specified bandwidth with Maximum Hold Mode, and record the maximum value.

**Above 1GHz:**

- a. The Product was placed on the non-conductive turntable 0.8 m above the ground in a full anechoic chamber..
- b. Set the spectrum analyzer/receiver in Peak detector, Max Hold mode, and 1MHz RBW. Record the maximum field strength of all the pre-scan process in the full band when the antenna is varied in both horizontal and vertical, and the turntable is rotated from 0 to 360 degrees.
- c. For each frequency whose maximum record was higher or close to limit, measure its AV value: rotate the turntable from 0 to 360 degrees to find the degree where Product radiated the maximum emission, then set the test frequency analyzer/receiver to AV value and specified bandwidth with Maximum Hold Mode, and record the maximum value.

Above 1GHz

The amplitude of spurious emissions which are attenuated by more than 20Db below the permissible value has no need to be reported.

CO., LTD

## 7.4 Test Results

Temperature:	26°C	Relative Humidity:	54%
Pressure:	101KPa	Polarization :	Horizontal
Test Mode:	USB+HDMI+earphone+Adapter+LAN	Remark:	N/A

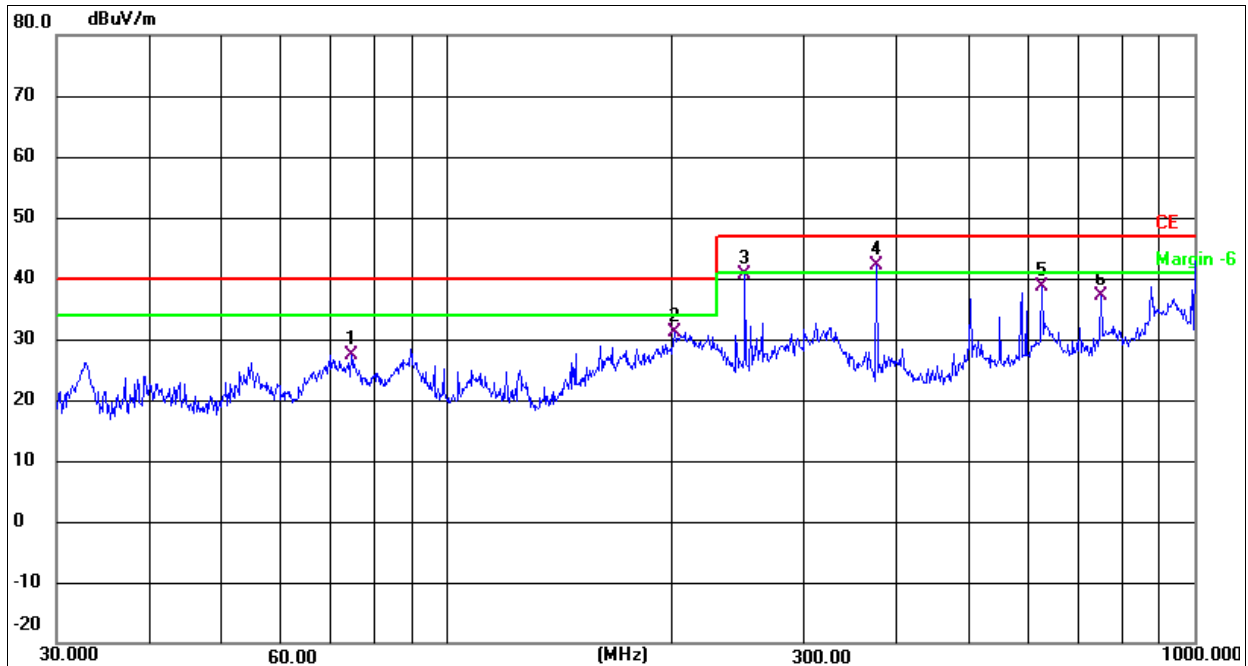

1. Factor = Antenna Factor + Cable Loss – Pre-amplifier.
2. Measurement=Reading Level+ Correct Factor
3. Over=Measurement-Limit

No.	Frequency (MHz)	Reading (dBuV)	Factor (dB/m)	Level (dBuV/m)	Limit (dBuV/m)	Margin (dB)	Detector
1	74.3954	41.78	-14.42	27.36	40.00	-12.64	QP
2	201.3930	44.64	-13.48	31.16	40.00	-8.84	QP
3	250.3012	51.97	-11.28	40.69	47.00	-6.31	QP
4 *	374.6225	49.54	-7.44	42.10	47.00	-4.90	QP
5	625.0779	39.72	-1.07	38.65	47.00	-8.35	QP
6	750.1082	35.81	1.34	37.15	47.00	-9.85	QP

Temperature:	26°C	Relative Humidity:	54%
Pressure:	101KPa	Polarization :	Vertical
Test Mode:	USB+HDMI+earphone+Adapter+LAN	Remark:	N/A

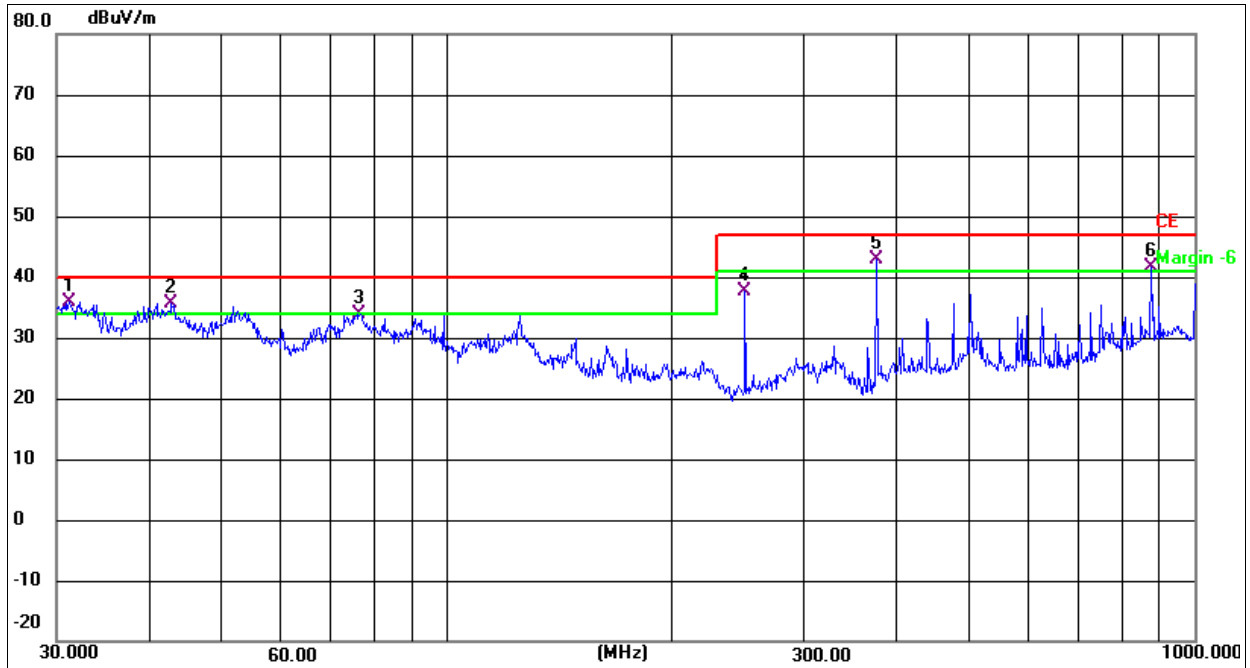

1. Factor = Antenna Factor + Cable Loss – Pre-amplifier.
2. Measurement=Reading Level+ Correct Factor
3. Over=Measurement-Limit

No.	Frequency (MHz)	Reading (dBuV)	Factor (dB/m)	Level (dBuV/m)	Limit (dBuV/m)	Margin (dB)	Detector
1 *	31.1798	47.78	-11.82	35.96	40.00	-4.04	QP
2 !	42.7496	46.05	-10.37	35.68	40.00	-4.32	QP
3	76.5119	48.98	-15.09	33.89	40.00	-6.11	QP
4	250.3012	49.01	-11.28	37.73	47.00	-9.27	QP
5 !	375.9385	50.25	-7.40	42.85	47.00	-4.15	QP
6 !	875.2470	38.19	3.44	41.63	47.00	-5.37	QP

## 8. Harmonic Current Emission(H)

### 8.1 Block Diagram Of Test Setup

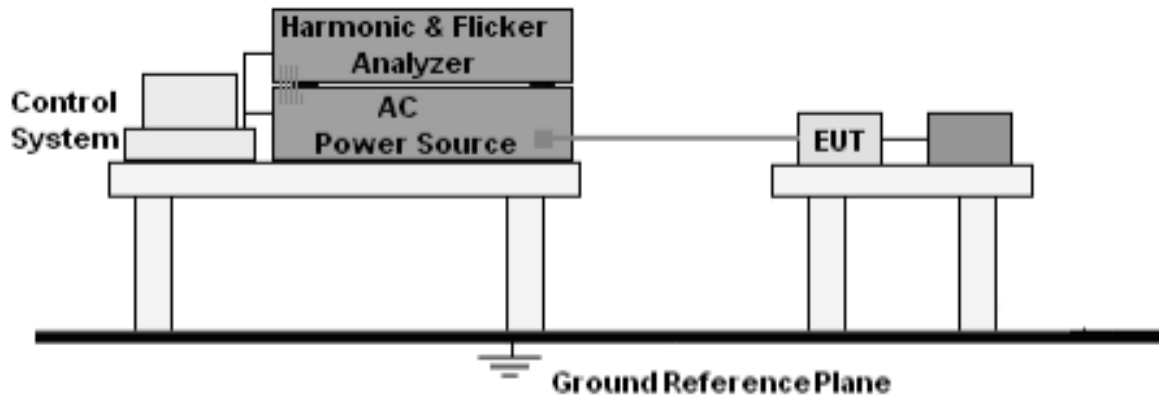

### 8.2 Limit

EN IEC 61000-3-2:2019+A1:2021

### 8.3 Test Procedure

- The Product was placed on the top of a non-conductive table above the ground and operated to produce the maximum harmonic components under normal operating conditions for each successive harmonic component in turn.
- The correspondent test program of test instrument to measure the current harmonics emanated from Product was chosen. The measure time shall be not less than the time necessary for the Product to be exercised.

### 8.4 Test Results

The Product belongs to Class A, and its power is less than 75W, so it deems to fulfil this standard without testing.

## 9. Voltage Fluctuations & Flicker(F)

### 9.1 Block Diagram Of Test Setup

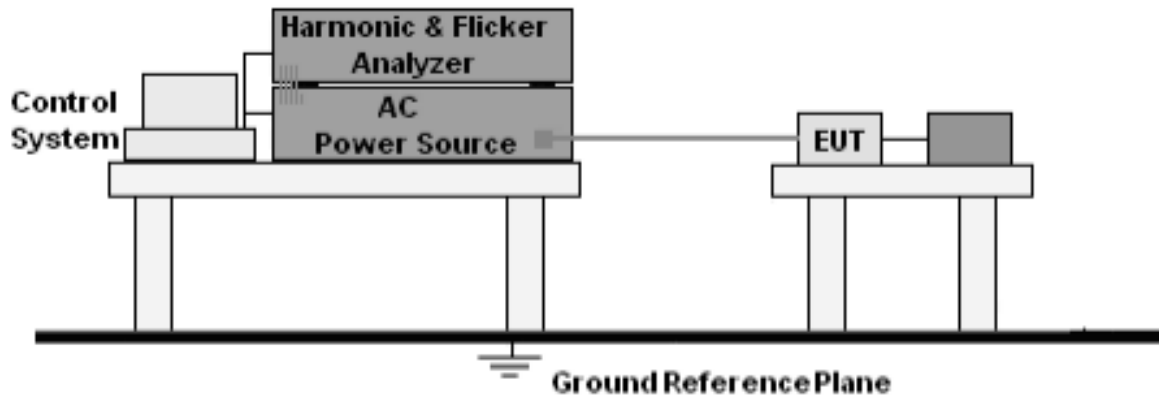

### 9.2 Limit

EN 61000-3-3:2013+A2:2021 Clause 5

### 9.3 Test Procedure

- The Product was placed on the top of a non-conductive table above the ground and operated to produce the most unfavorable sequence of voltage changes under normal operating conditions.
- During the flick test, the measure time shall include that part of whole operation cycle in which the Product produce the most unfavorable sequence of voltage changes. The observation period for short-term flicker indicator is 10 minutes and the observation period for long-term flicker indicator is 2 hours.

### 9.4 Test Results

The EUT is powered by the DC only, the test item is not applicable.

## 10. Immunity Test Of General The Performance Criteria

According To EN 301489 -17standard, The General Performance Criteria As Following:

Criteria	During test	After test (i.e. as a result of the application of the test)
A	Shall operate as intended. (see note). Shall be no loss of function. Shall be no unintentional transmissions.	Shall operate as intended. Shall be no degradation of performance. Shall be no loss of function. Shall be no loss of critical stored data.
B	May be loss of function.	Functions shall be self-recoverable. Shall operate as intended after recovering. Shall be no loss of critical stored data.
C	May be loss of function.	Functions shall be recoverable by the operator. Shall operate as intended after recovering. Shall be no loss of critical stored data.

NOTE: Operate as intended during the test allows a level of degradation in accordance with Minimum performance level.  
 Minimum performance level:  
 For equipment that supports a PER or FER, the minimum performance level shall be a PER or FER less than or equal to 10 %.  
 For equipment that does not support a PER or a FER, the minimum performance level shall be no loss of the wireless transmission function needed for the intended use of the equipment.

### PERFORMANCE FOR TT

The performance criteria B shall apply, except for voltage dips of 100 ms and voltage interruptions of 5 000 ms duration, for which performance criteria C shall apply. Tests shall be repeated with the EUT in standby mode (if applicable) to ensure that unintentional transmission does not occur. In systems using acknowledgement signals, it is recognized that an acknowledgement (ACK) or not-acknowledgement (NACK) transmission may occur, and steps should be taken to ensure that any transmission resulting from the application of the test is correctly interpreted.

### PERFORMANCE FOR TR

The performance criteria B shall apply, except for voltage dips of 100 ms and voltage interruptions of 5 000 ms duration for which performance criteria C shall apply. Where the EUT is a transceiver, under no circumstances, shall the transmitter operate unintentionally during the test. In systems using acknowledgement signals, it is recognized that an ACK or NACK transmission may occur, and steps should be taken to ensure that any transmission resulting from the application of the test is correctly interpreted.

### PERFORMANCE FOR CT

The performance criteria A shall apply. Tests shall be repeated with the EUT in standby mode (if applicable) to ensure that unintentional transmission does not occur. In systems using acknowledgement signals, it is recognized that an Acknowledgement (ACK) or Not Acknowledgement (NACK) transmission may occur, and steps should be taken to ensure that any transmission resulting from the application of the test is correctly interpreted.

### PERFORMANCE FOR CR

The performance criteria A shall apply. Where the EUT is a transceiver, under no circumstances, shall the transmitter operate unintentionally during the test. In systems using acknowledgement signals, it is recognized that an ACK or NACK transmission may occur, and steps should be taken to ensure that any transmission resulting from the application of the test is correctly interpreted.

## 11. Electrostatic Discharge (ESD)

### 11.1 Test Specification

<b>Test Port</b>	: Enclosure port
<b>Discharge Impedance</b>	: 330 ohm / 150 pF
<b>Discharge Mode</b>	: Single Discharge
<b>Discharge Period</b>	: one second between each discharge

### 11.2 Block Diagram Of Test Setup

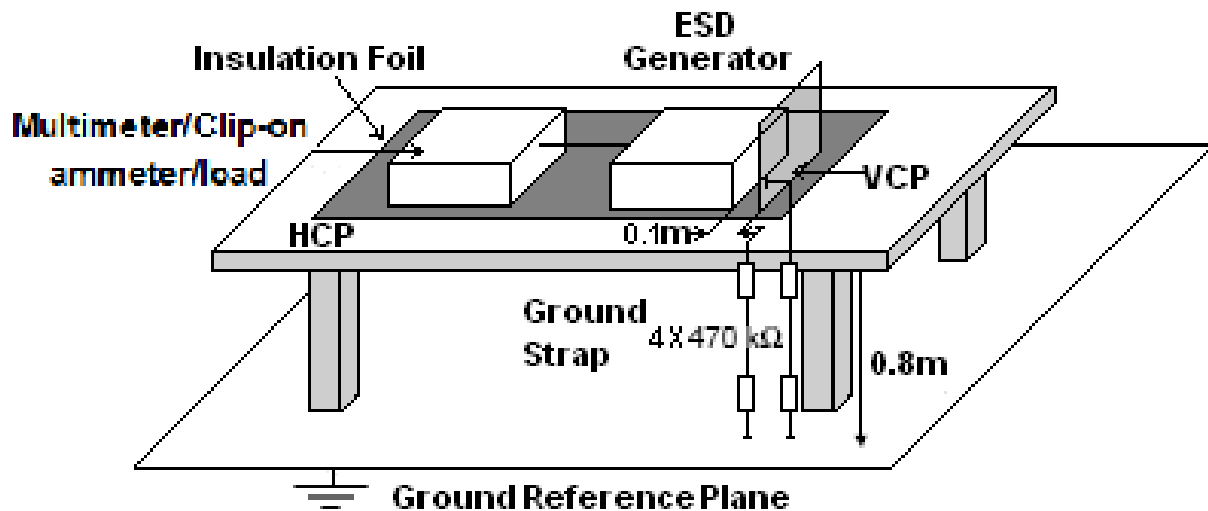

### 11.3 Test Procedure

- Electrostatic discharges were applied only to those points and surfaces of the Product that are accessible to users during normal operation.
- The test was performed with at least ten single discharges on the pre-selected points in the most sensitive polarity.
- The time interval between two successive single discharges was at least 1 second.
- The ESD generator was held perpendicularly to the surface to which the discharge was applied and the return cable was at least 0.2 meters from the Product.
- Contact discharges were applied to the non-insulating coating, with the pointed tip of the generator penetrating the coating and contacting the conducting substrate.
- Air discharges were applied with the round discharge tip of the discharge electrode approaching the Product as fast as possible (without causing mechanical damage) to touch the Product. After each discharge, the ESD generator was removed from the Product and re-triggered for a new single discharge. The test was repeated until all discharges were complete.



## 11.4 Test Results

Temperature :	26 °C	Relative Humidity :	54%
Pressure :	101KPa	Test Mode:	USB+HDMI+earphone+Adapter+LAN

Mode	Air Discharge (Test result)								Contact Discharge (Test result)								Perform Criteria	Judgment
	2		4		8		15		2		4		6		8			
Test level (kV)																		
Test Location	+	-	+	-	+	-	+	-	+	-	+	-	+	-	+	-		
HCP									A	A	A	A					TT,TR	PASS
VCP									A	A	A	A					TT,TR	PASS
enclosure	A	A	A	A	A	A			A	A	A	A					TT,TR	PASS
Keys	A	A	A	A	A	A											TT,TR	PASS
Port	B	B	B	B	B	B			A	A	A	A					TT,TR	PASS

Note B: The EUT is interrupted during testing and can be restored automatically at the end of the test.

## Note:

- 1) P/N denotes the Positive/Negative polarity of the output voltage.
- 2) Test condition:  
 Direct / Indirect (HCP/VCP) discharges: Minimum 50 times (Positive/Negative) at each point. Air discharges: Minimum 10 times (Positive/Negative) at each point.
- 3) N/A - denotes test is not applicable in this test report
- 4) There was not any unintentional transmission in standby mode

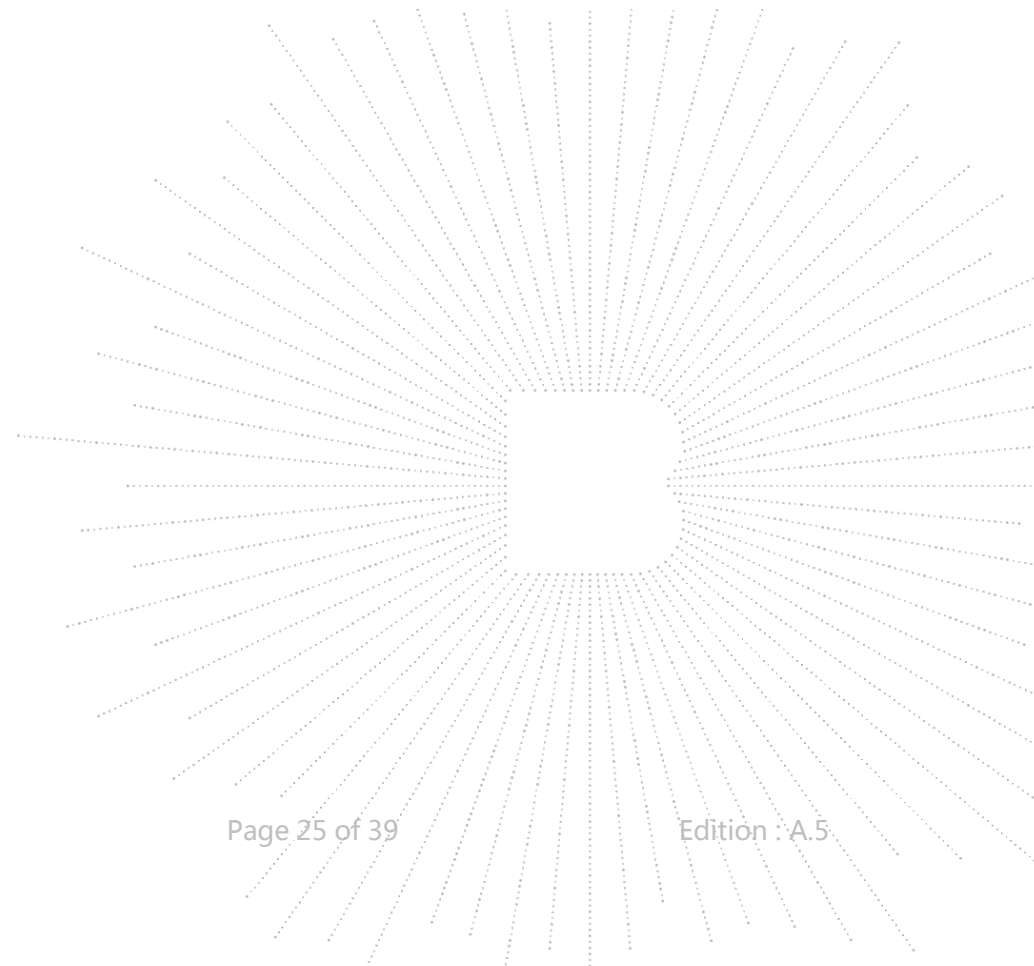

## 12. Continuous RF Electromagnetic Field Disturbances(RS)

### 12.1 Test Specification

<b>Test Port</b>	:	Enclosure port
<b>Step Size</b>	:	1%
<b>Modulation</b>	:	1kHz, 80% AM
<b>Dwell Time</b>	:	1 second
<b>Polarization</b>	:	Horizontal & Vertical

### 12.2 Block Diagram Of Test Setup

Below 1GHz:

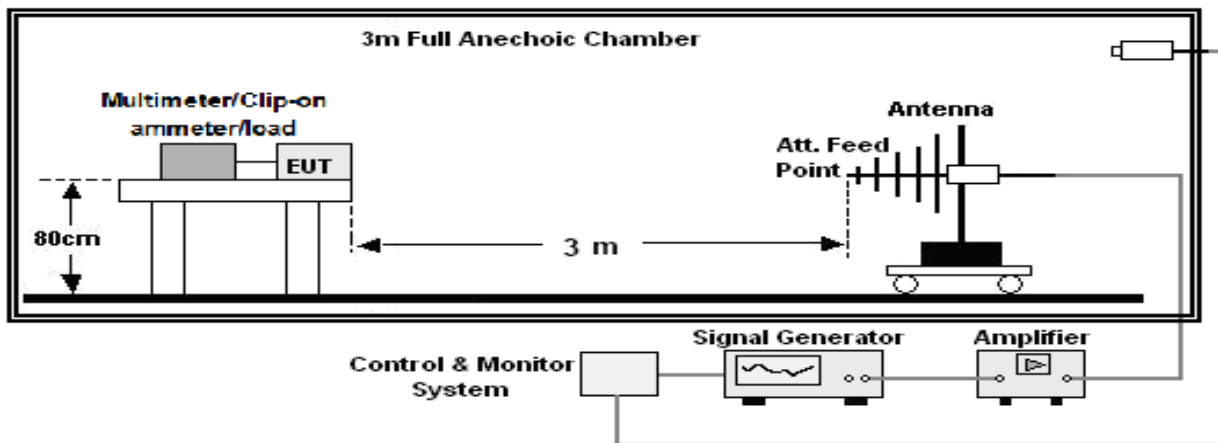

Above 1GHz:

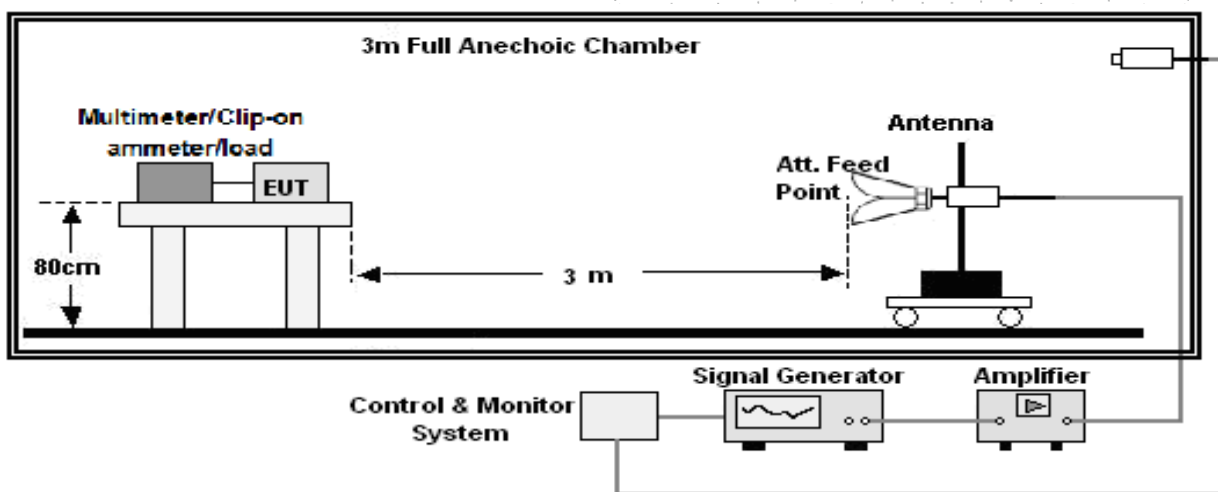

### 12.3 Test Procedure

- a. The testing was performed in a fully-anechoic chamber. The transmit antenna was located at a distance of 3 meters from the Product.
- b. The frequency range is swept from 80MHz to 6000MHz, with the signal 80% amplitude modulated with a 1 kHz sine wave, and the step size was 1%.
- c. The dwell time at each frequency shall not be less than the time necessary for the EUT to be exercised and to be able to respond, but should not exceed 5 s at each of the frequencies during the scan.
- d. The test was performed with the Product exposed to both vertically and horizontally polarized fields on each of the four sides.
- e. For Broadcast reception function: Group 2 not apply in this test.

### 12.4 Test Results

Temperature :	26 °C	Relative Humidity :	54%
Pressure :	101KPa	Test Mode:	USB+HDMI+earphone+Adapter+LAN

Frequency Range (MHz)	RF Field Position	R.F. Field Strength	Azimuth	Perform Criteria	Test Result	Judgment
80~6000	H / V	3 V/m (rms) AM Modulated 1000Hz, 80%	Front	CT,CR	A	PASS
			Rear			
			Left			
			Right			

Note:

- 1) P/N denotes the Positive/Negative polarity of the output voltage.
- 2) N/A - denotes test is not applicable in this test report.
- 3) There was no change operated with initial operating during the test.
- 4) There was not any unintentional transmission in standby mode

### 13. Electrical Fast Transients/Burst (EFT)

#### 13.1 Test Specification

<b>Test Port</b>	:	input AC / DC power port
<b>Impulse Frequency</b>	:	5 kHz
<b>Impulse Wave-shape</b>	:	5/50 ns
<b>Burst Duration</b>	:	15 ms
<b>Burst Period</b>	:	300 ms
<b>Test Duration</b>	:	2 minutes per polarity

#### 13.2 Block Diagram Of EUT Test Setup

For input AC / DC power port:

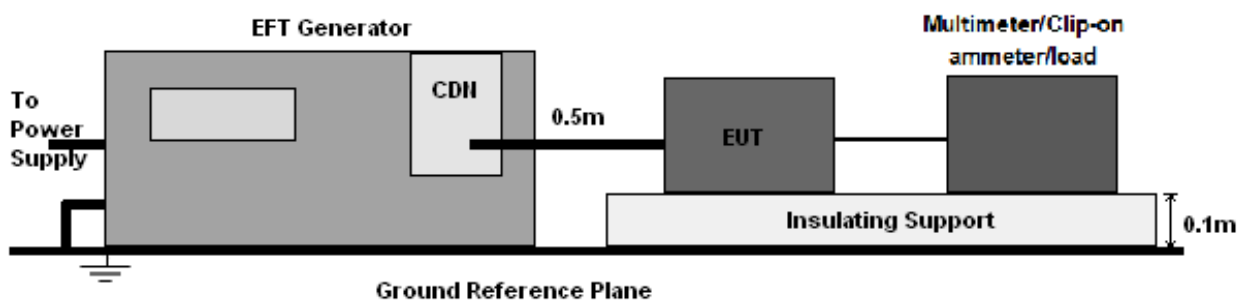

#### 13.3 Test Procedure

- The Product and support units were located on a non-conductive table above ground reference plane.
- A 0.5m-long power cord was attached to Product during the test.

#### 13.4 Test Results

The EUT is powered by the DC only, the test item is not applicable.

## 14. Surges Immunity Test

### 14.1 Test Specification

<b>Test Port</b>	:	input AC / DC power port
<b>Wave-Shape</b>	:	Open Circuit Voltage - 1.2 / 50 us Short Circuit Current - 8 / 20 us
<b>Pulse Repetition Rate</b>	:	1 pulse / min.
<b>Phase Angle</b>	:	0° / 90° / 180° / 270°
<b>Test Events</b>	:	5 pulses (positive & negative) for each polarity

### 14.2 Block Diagram Of EUT Test Setup

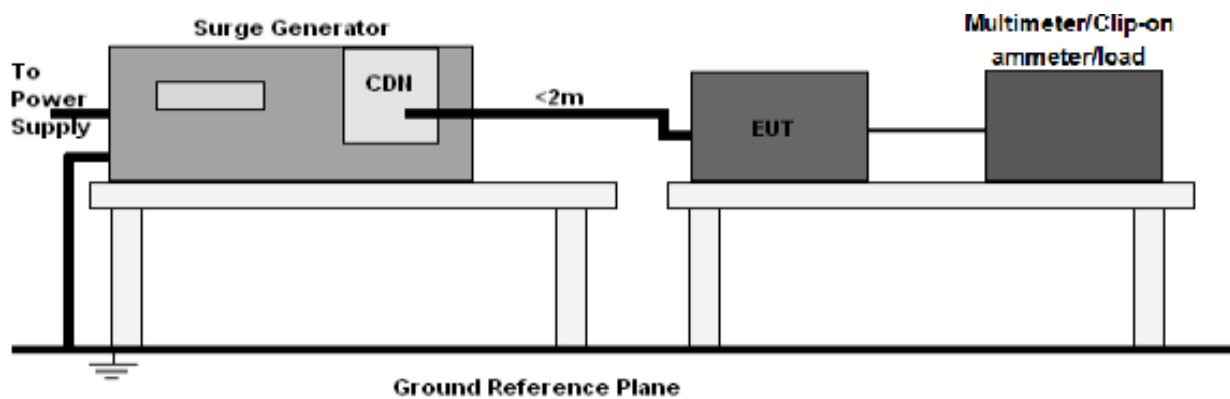

### 14.3 Test Procedure

- The surge is to be applied to the Product power supply terminals via the capacitive coupling network. Decoupling networks are required in order to avoid possible adverse effects on equipment not under test that may be powered by the same lines, and to provide sufficient decoupling impedance to the surge wave.
- The power cord between the Product and the coupling/decoupling networks shall be 2 meters in length (or shorter). Interconnection line between the Product and the coupling/decoupling networks shall be 2 meters in length (or shorter).

### 14.4 Test Result

The EUT is powered by the DC only, the test item is not applicable.

## 15. Continuous Induced RF Disturbances (CS)

### 15.1 Test Specification

<b>Test Port</b>	:	input AC / DC power port
<b>Step Size</b>	:	1%
<b>Modulation</b>	:	1kHz, 80% AM
<b>Dwell Time</b>	:	1 second

### 15.2 Block Diagram Of EUT Test Setup

For input AC / DC power port:

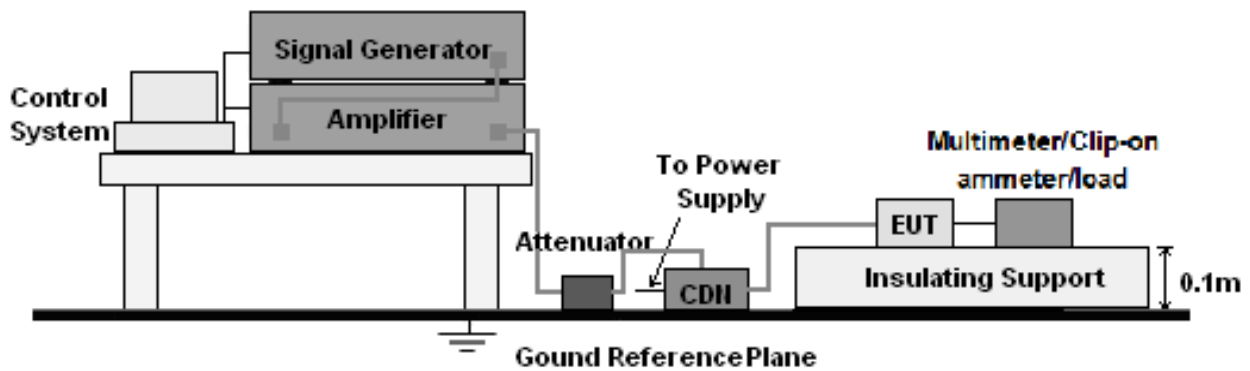

### 15.3 Test Procedure

**For input AC/ DC power port:**

- The Product and support units were located at a ground reference plane with the interposition of a 0.1 m thickness insulating support and the CDN was located on GRP directly.
- The frequency range is swept from 150 kHz to 10MHz, 10MHz to 30MHz, 30MHz to 80MHz with the signal 80% amplitude modulated with a 1 kHz sine wave, and the step size was 1% of fundamental.
- The dwell time at each frequency shall be not less than the time necessary for the Product to be able to respond.

### 15.4 Test Result

The EUT is powered by the DC only, the test item is not applicable.

## 16. Voltage Dips And Interruptions (DIPS)

### 16.1 Test Specification

<b>Test Port</b>	:	input AC power port
<b>Phase Angle</b>	:	0°, 180°
<b>Test cycle</b>	:	3 times

### 16.2 Block Diagram Of EUT Test Setup

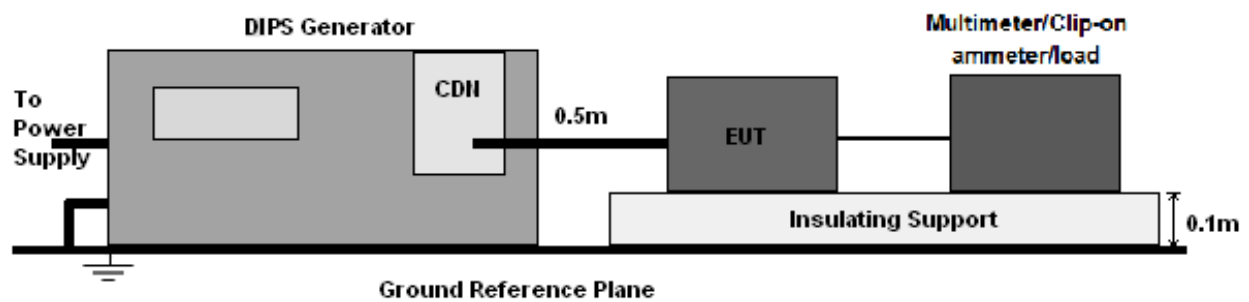

### 16.3 Test Procedure

- The Product and support units were located on a non-conductive table above ground floor.
- Set the parameter of tests and then perform the test software of test simulator.
- Conditions changes to occur at 0 degree crossover point of the voltage waveform.

### 16.4 Test Result

The EUT is powered by the DC only, the test item is not applicable.



**17. EUT Photographs**

**EUT Photo 1**



**EUT Photo 2**





EUT Photo 3

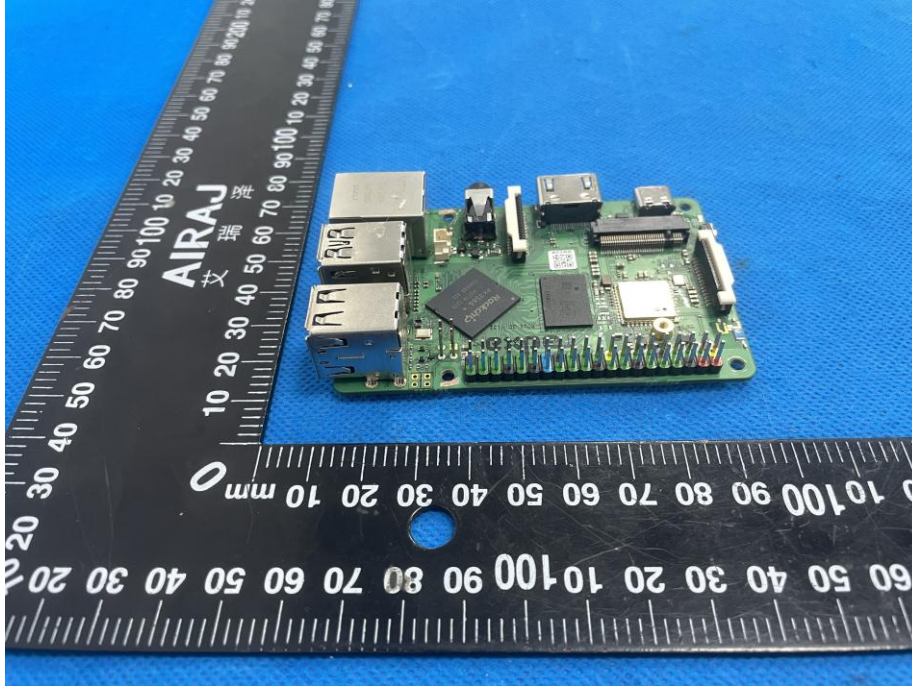

EUT Photo 4

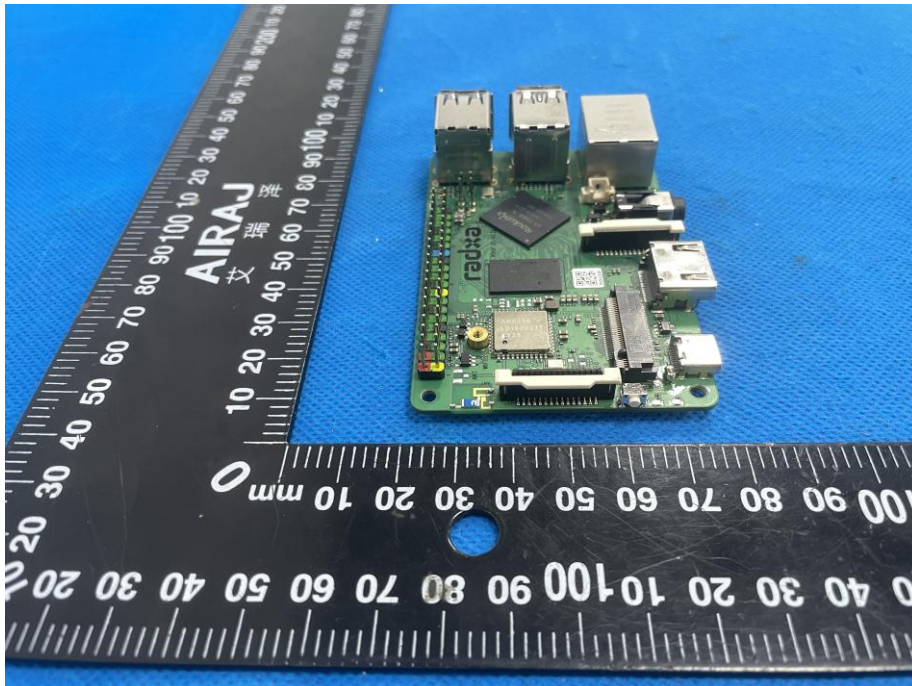

EUT Photo 5

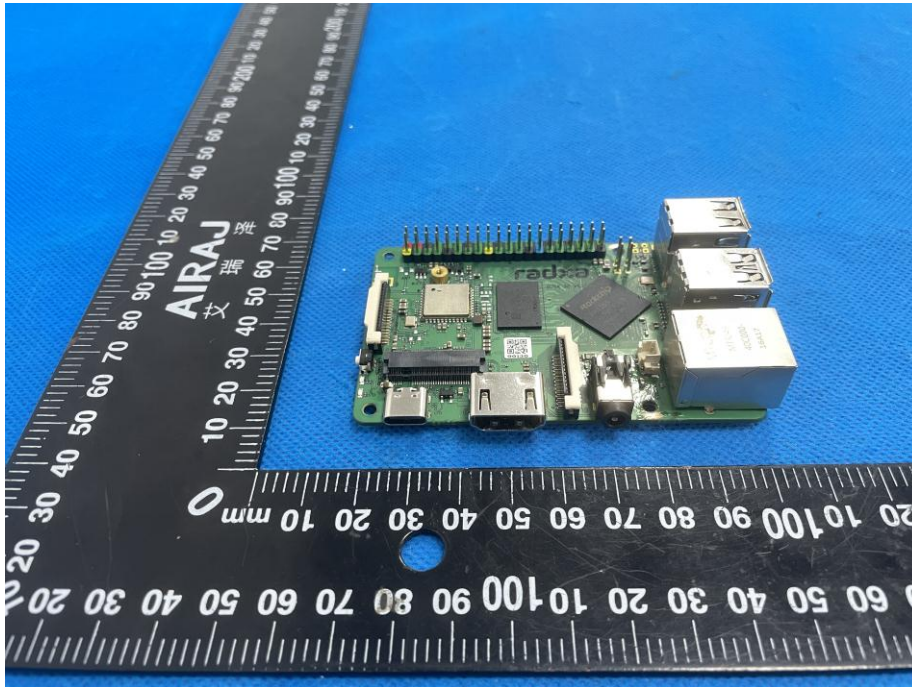

EUT Photo 6

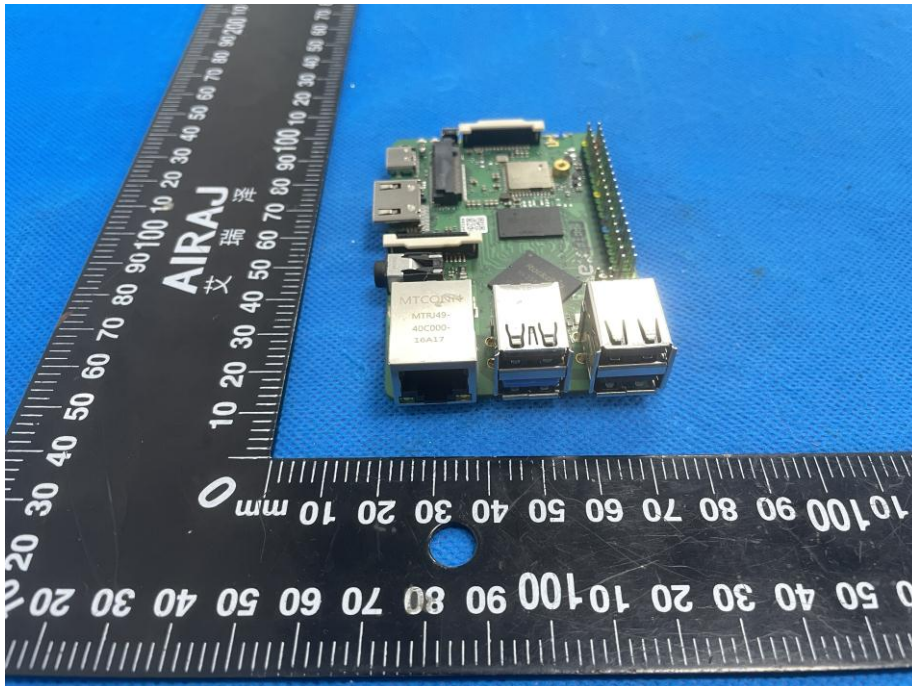



EUT Photo 7



EUT Photo 8

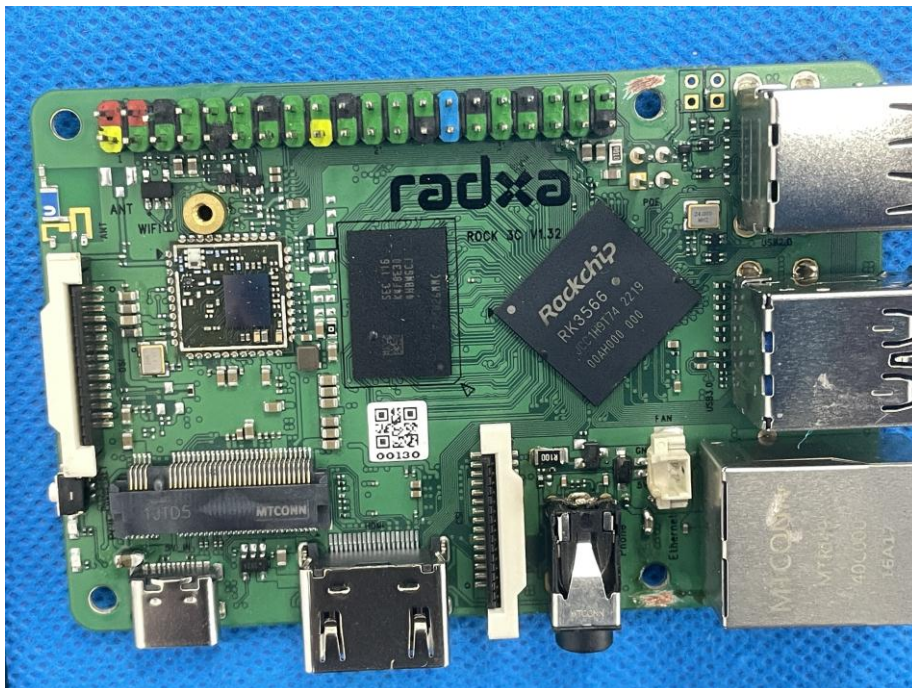



## 18. EUT Test Setup Photographs

Conducted emissions



TELE



Radiated emissions

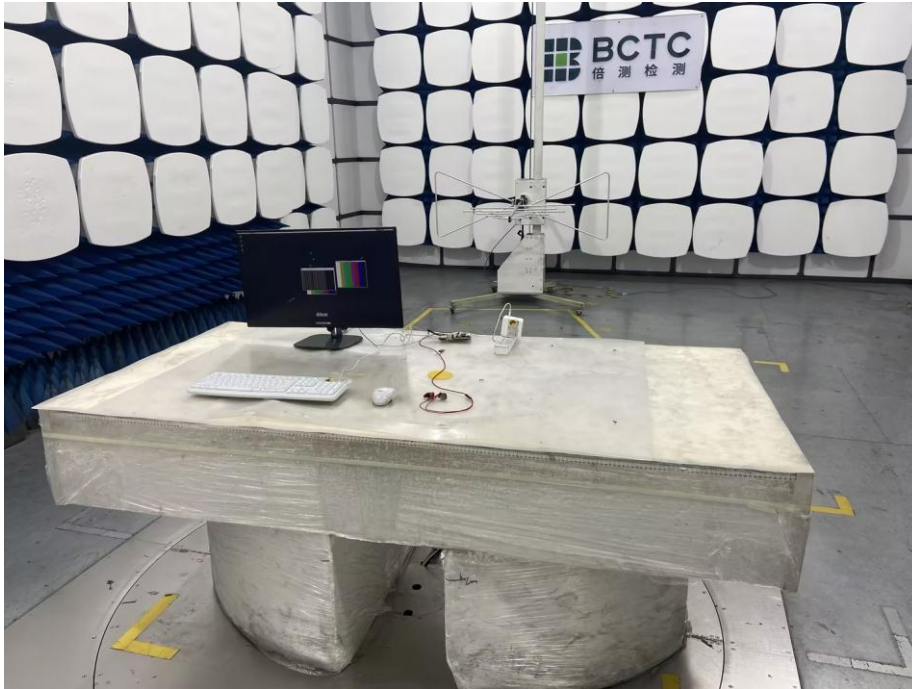

ESD

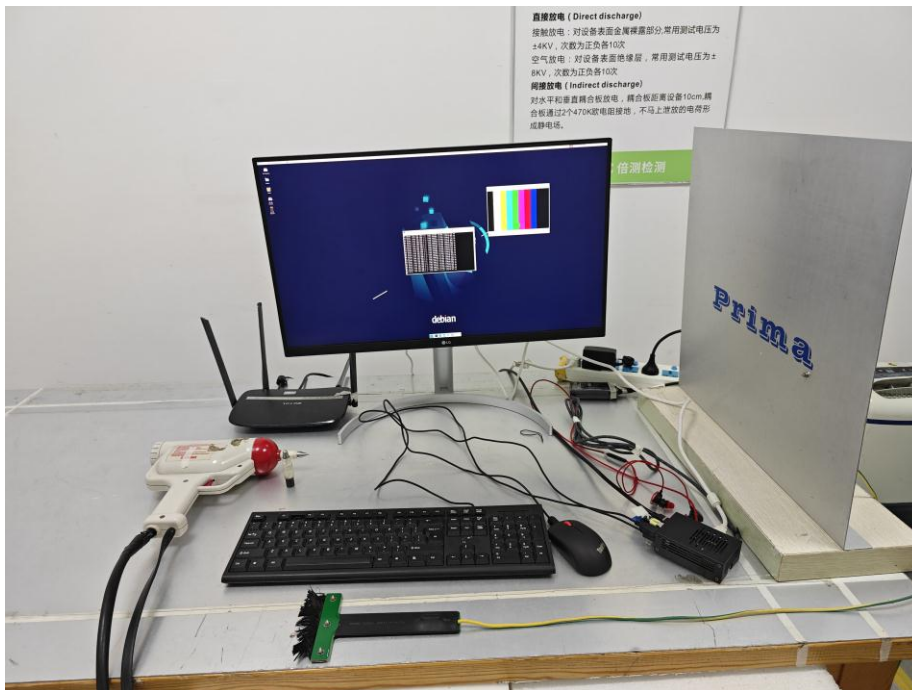



RS

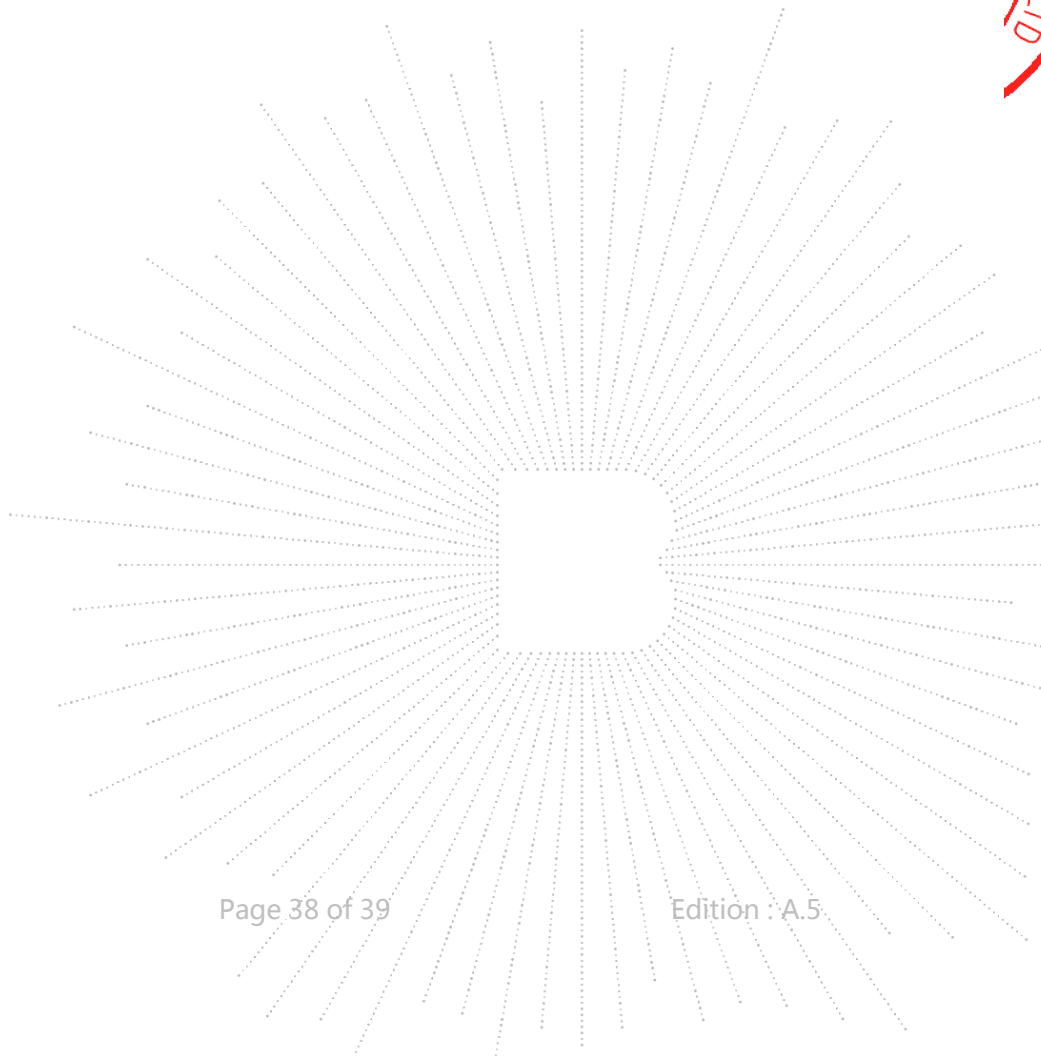



**STATEMENT**

1. The equipment lists are traceable to the national reference standards.
2. The test report can not be partially copied unless prior written approval is issued from our lab.
3. The test report is invalid without the "special seal for inspection and testing".
4. The test report is invalid without the signature of the approver.
5. The test process and test result is only related to the Unit Under Test.
6. Sample information is provided by the client and the laboratory is not responsible for its authenticity.
7. The test report without CMA mark is only used for scientific research, teaching, enterprise product development and internal quality control purposes.
8. The quality system of our laboratory is in accordance with ISO/IEC17025.
9. If there is any objection to this test report, the client should inform issuing laboratory within 15 days from the date of receiving test report.

**Address:**

1-2/F., Building B, Pengzhou Industrial Park, No.158, Fuyuan 1st Road, Zhancheng, Fuhai Subdistrict, Bao'an District, Shenzhen, Guangdong, China

TEL : 400-788-9558

P.C.: 518103

FAX : 0755-33229357

Website : <http://www.chnbctc.com>

E-Mail : [bctc@bctc-lab.com.cn](mailto:bctc@bctc-lab.com.cn)

**\*\*\*\*\* END \*\*\*\*\***