

Table of Content

| | |
|---------|--------------------------------|
| Page 1 | 01.Index_and_Notes |
| Page 2 | 02.Revision_History |
| Page 3 | 03.Block_Diagram |
| Page 4 | 04.HDMI0_OUT |
| Page 5 | 05.Ethernet |
| Page 6 | 06.MicroSD Card |
| Page 7 | 07.PCIE2.0 |
| Page 8 | 08.AUDIO |
| Page 9 | 09.LCD_eDP_TX |
| Page 10 | 10.MIPI_LCD_TX0 |
| Page 11 | 11.MIPI_CSI_RX |
| Page 12 | 12.USB_OTG/ HUB |
| Page 13 | 13.USB_HOST |
| Page 14 | 14.FAN_RTC_BAT |
| Page 15 | 15.Power-DC_IN |
| Page 16 | 16.40PIN_CONNECT |
| Page 17 | 17.GPIO+VCC_Connector |
| Page 18 | 18.High Speed Serial_Connector |
| Page 19 | 19.IO_Connector |
| Page 20 | 20.MIPI_LCD_TX1 |



Revision History

| Version | Date | By | Change Dscription | Approved |
|----------------|-------------|-----------|--------------------------|-----------------|
| V1.0 | 2021-10 | | | |
| V1.1 | 2021-12 | | | |
| V1.3 | 2022-09 | | | |
| | | | | |



Ref Block Diagram

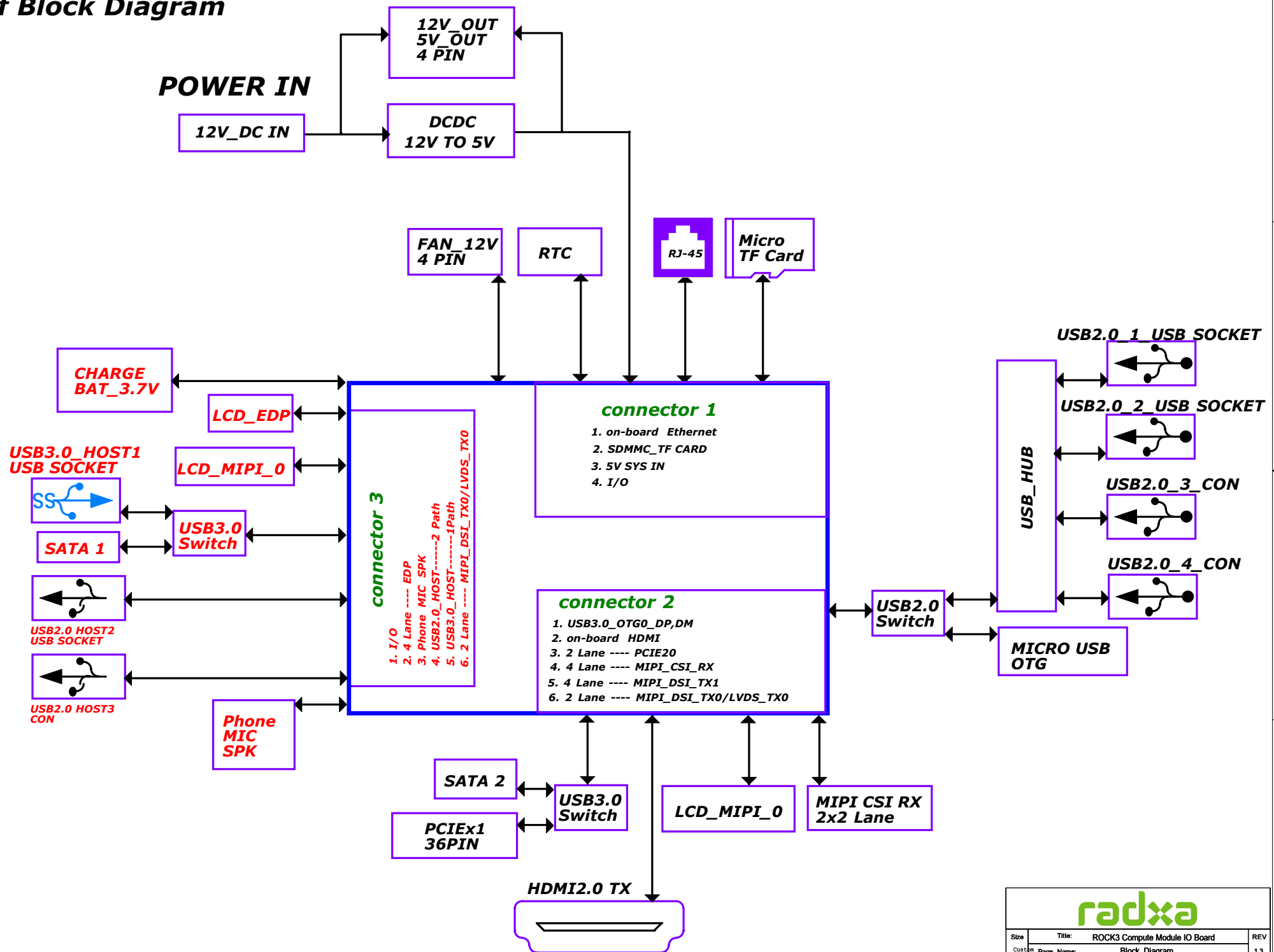

HDMI2.0 TX

Cj <= 0.4pF

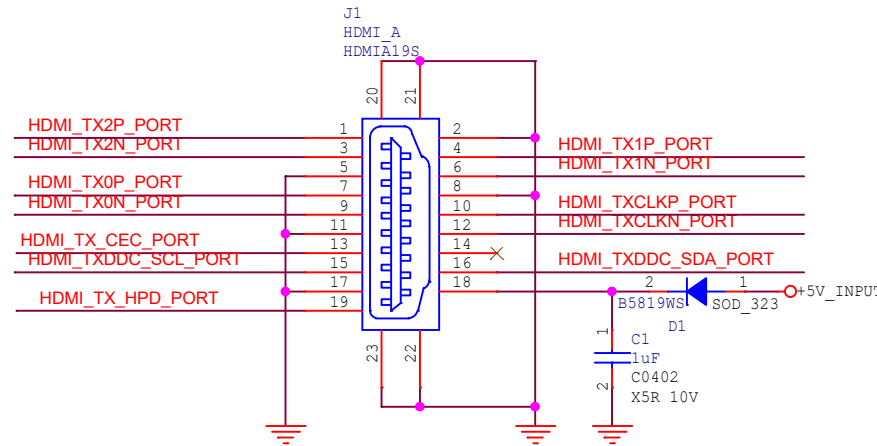
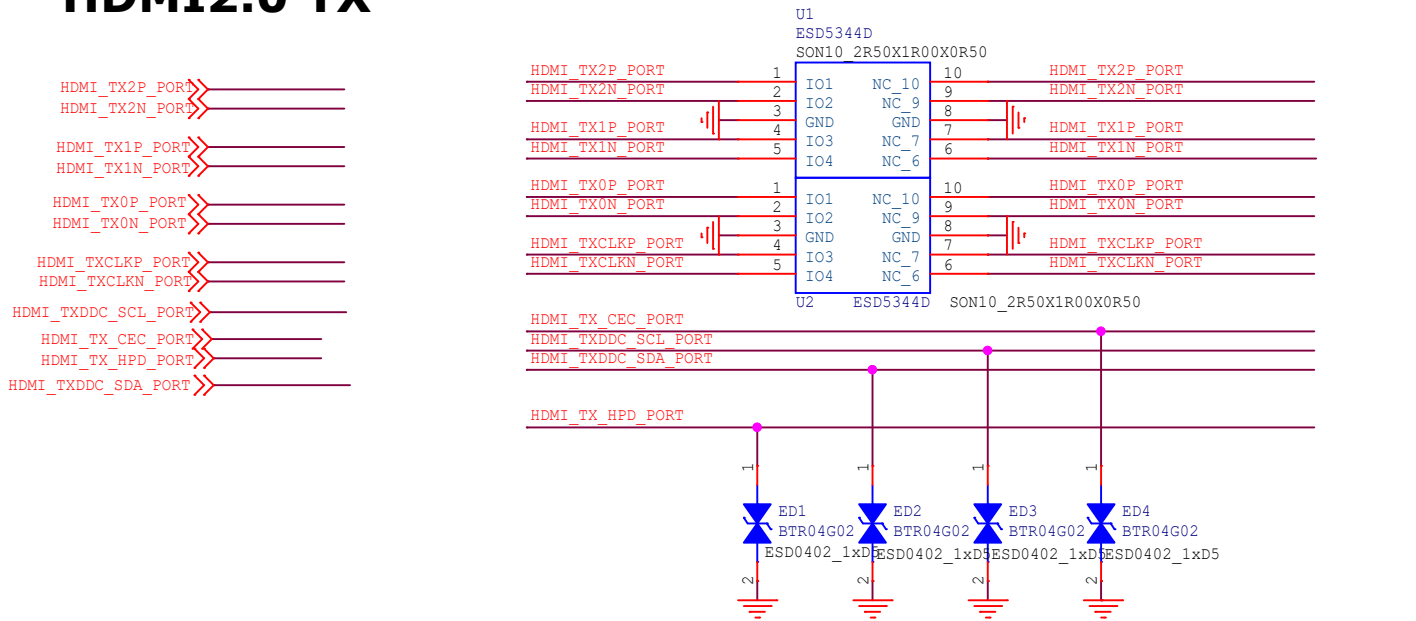

| | | |
|---|--------------------------------------|-----|
| Size | Title: ROCK3 Compute Module IO Board | REV |
| A4 | Page Name: HDMIO OUT | 1.3 |
| Date: Wednesday, December 21, 2022 Sheet 04 of 20 | | |

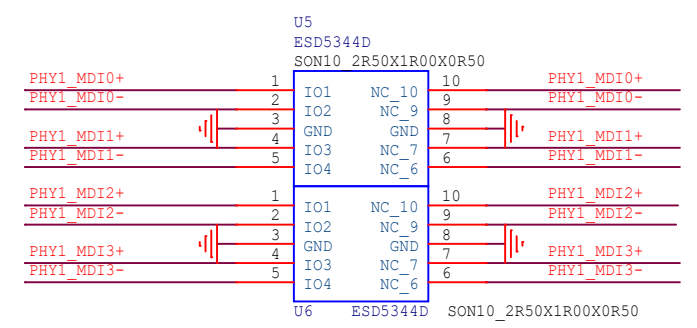
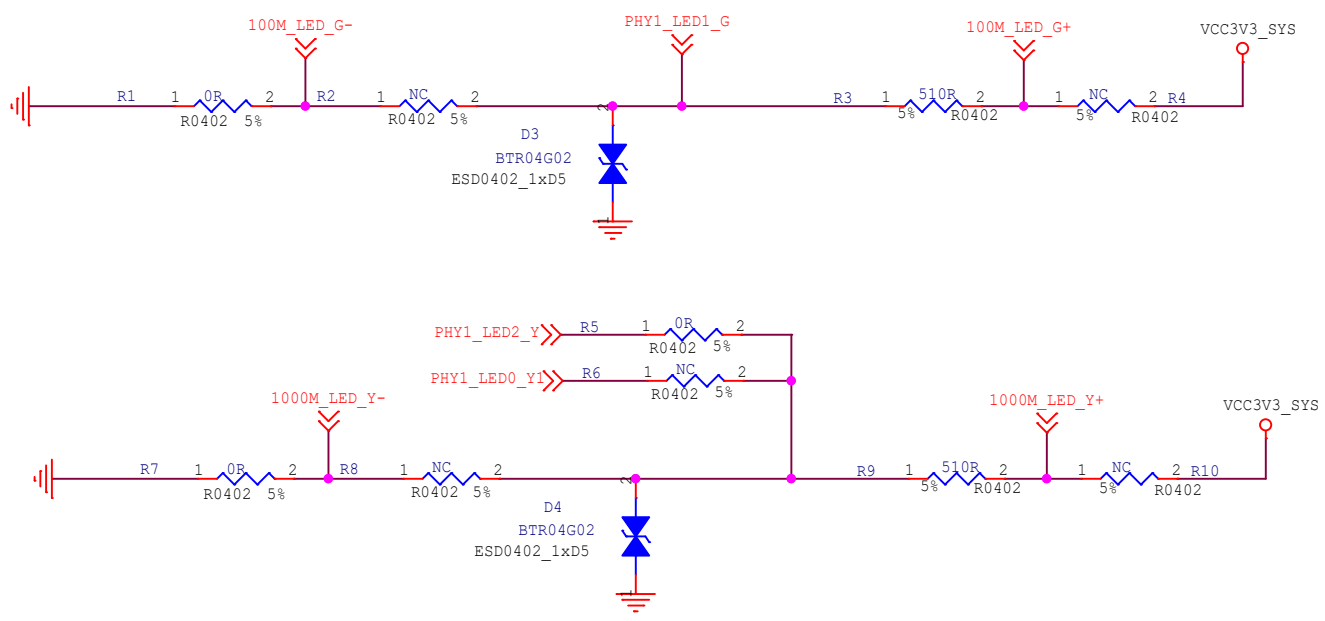
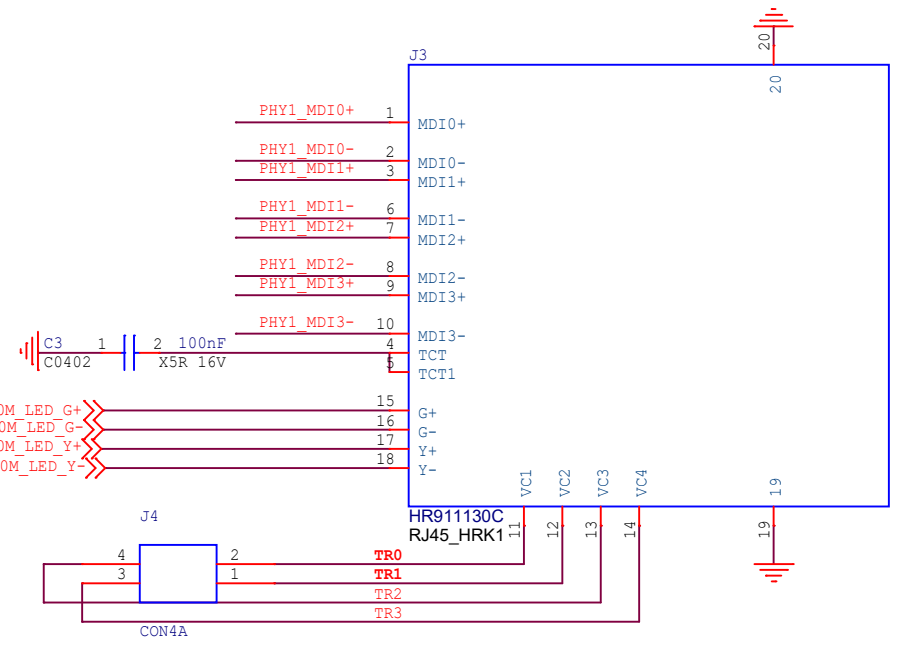
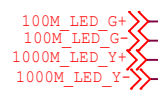
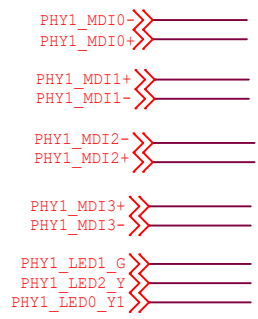

| | | |
|---|--------------------------------------|-----|
| Size | Title: ROCK3 Compute Module IO Board | REV |
| A4 | Page Name: Ethernet | 1.3 |
| Date: Wednesday, December 21, 2022 Sheet 05 of 20 | | |

MicroSD Card

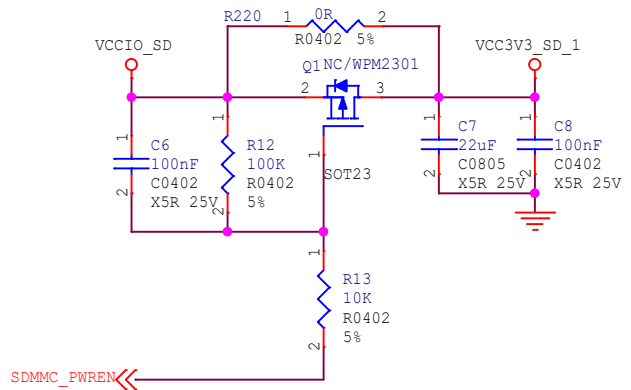
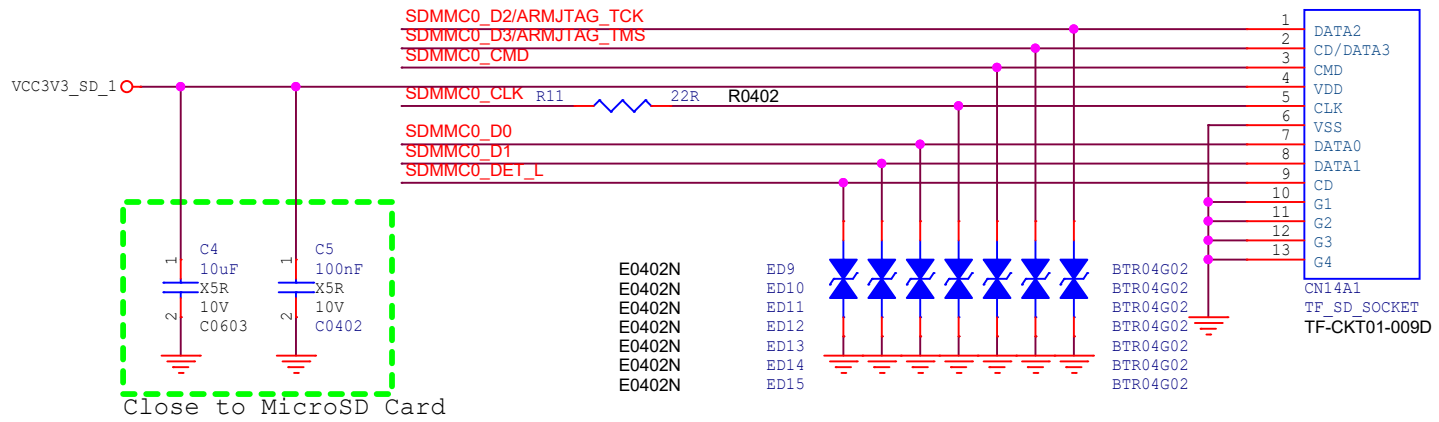
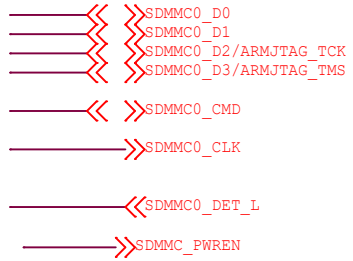

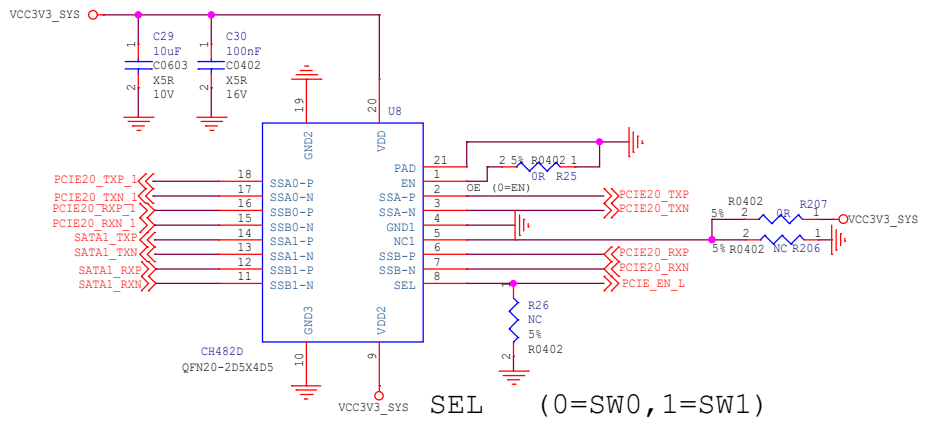
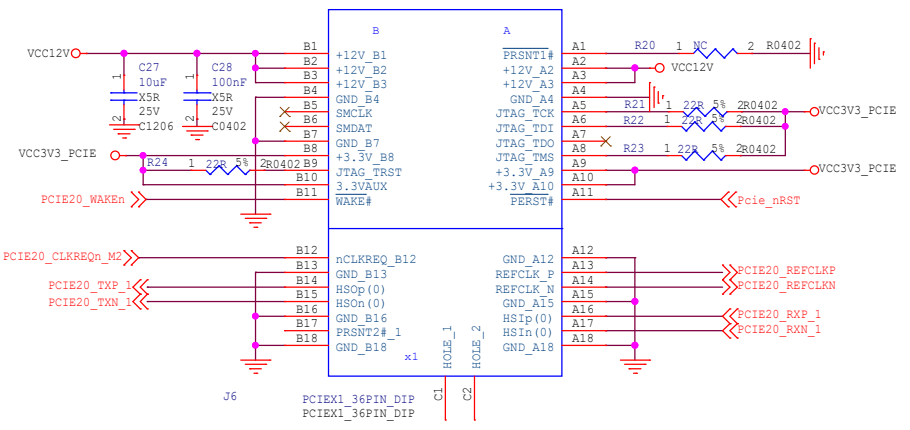
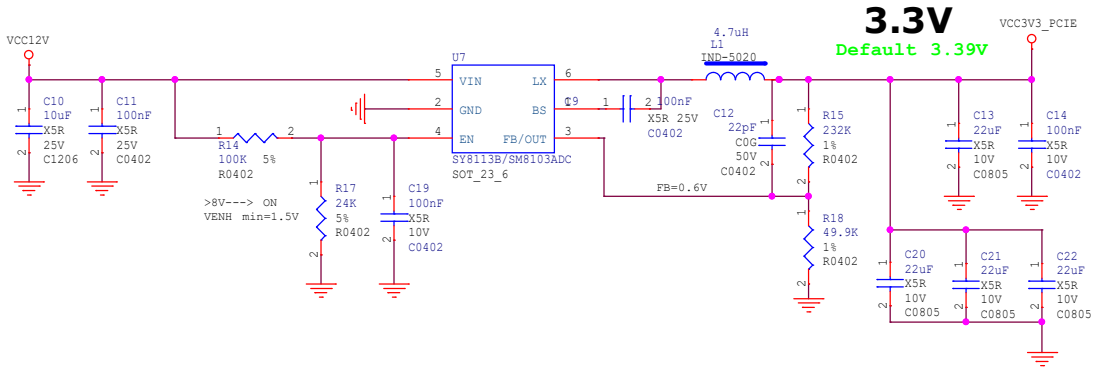

SATA3.0 Port2

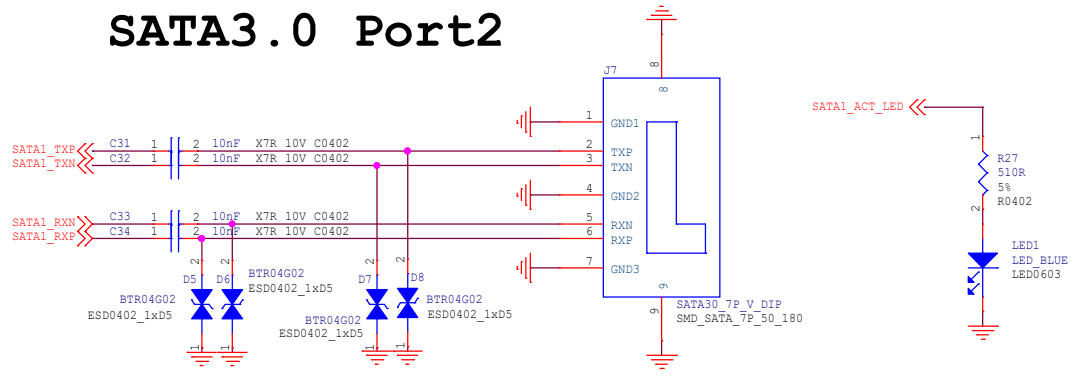



| | | |
|---|---|--------------|
| Size | Title: ROCK3 Compute Module IO Board | REV |
| B | Page Name: PCIE2.0 | 1.3 |
| Date: Wednesday, December 21, 2022 | | |
| Sheet 07 | | of 20 |

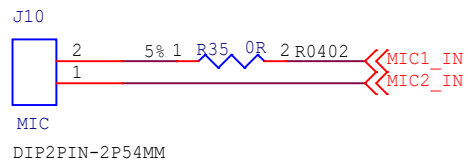
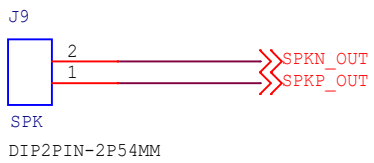
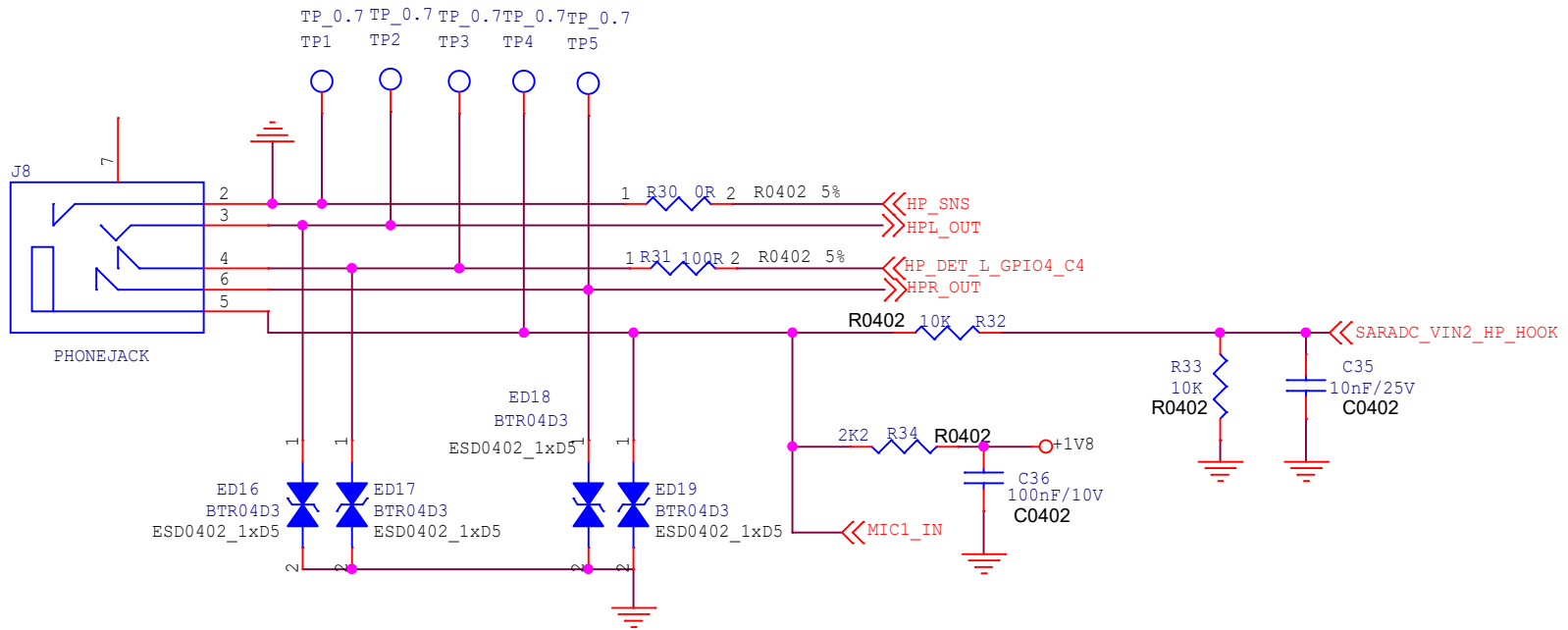

radxa

| | | |
|---|--------------------------------------|-----|
| Size | Title: ROCK3 Compute Module IO Board | REV |
| A | Page Name: AUDIO | 1.3 |
| Date: Wednesday, December 21, 2022 Sheet 08 of 20 | | |

Single-eDP LCM

- >>> EDP_TX_D0P
- >>> EDP_TX_D0N
- >>> EDP_TX_D1P
- >>> EDP_TX_D1N
- >>> EDP_TX_D2P
- >>> EDP_TX_D2N
- >>> EDP_TX_D3P
- >>> EDP_TX_D3N
- >>> EDP_TX_AUXP
- >>> EDP_TX_AUXN
- >>> LCD0_BL_EN
- >>> LCD0_BL_PWM5
- >>> LCD1_PWREN_H

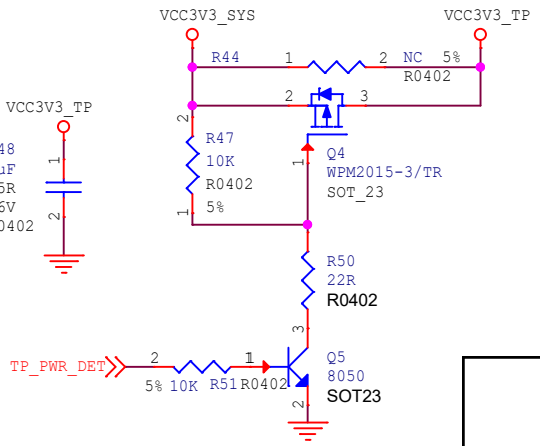
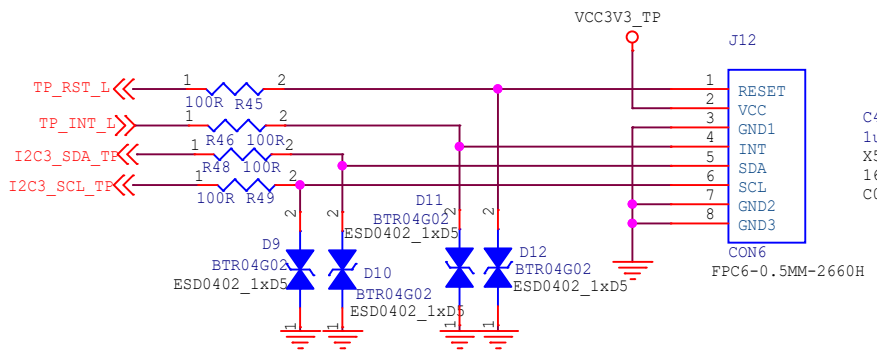
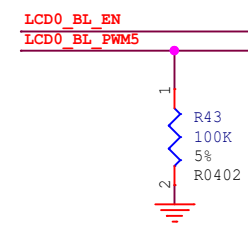
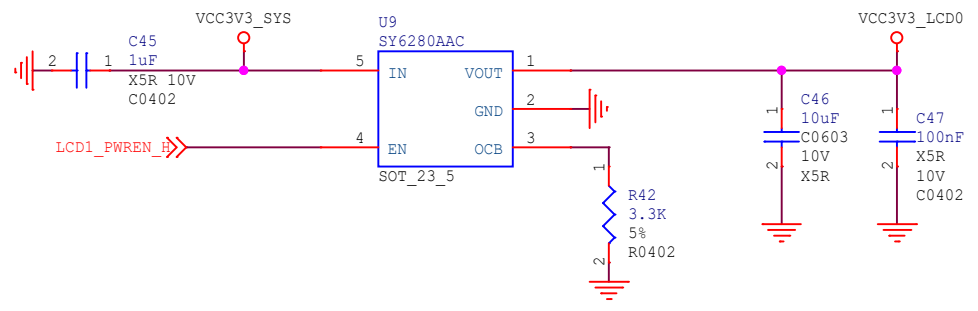
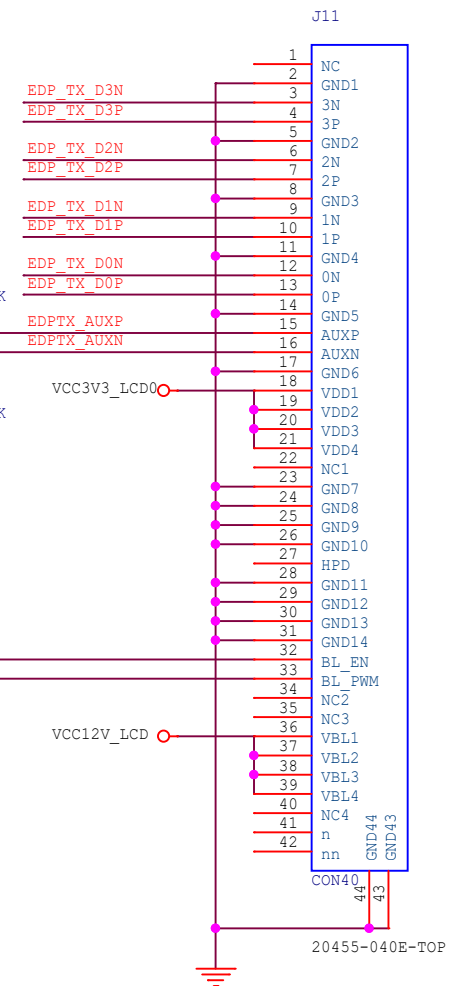
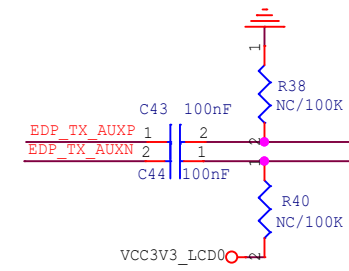
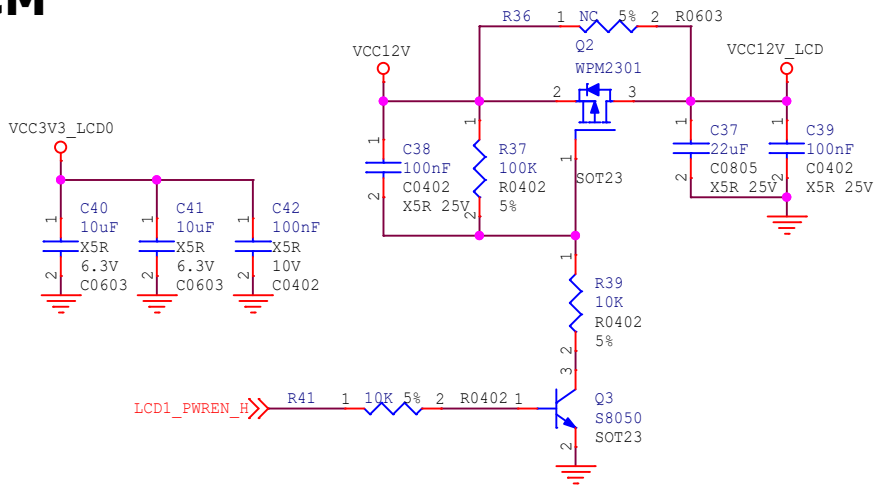

| | | |
|------------------------------------|--------------------------------------|----------|
| Size | Title: ROCK3 Compute Module IO Board | REV |
| A4 | Page Name: LCD_eDP TX | 1.3 |
| Date: Wednesday, December 21, 2022 | Sheet | 09 of 20 |

MIPI_LCD_TX0

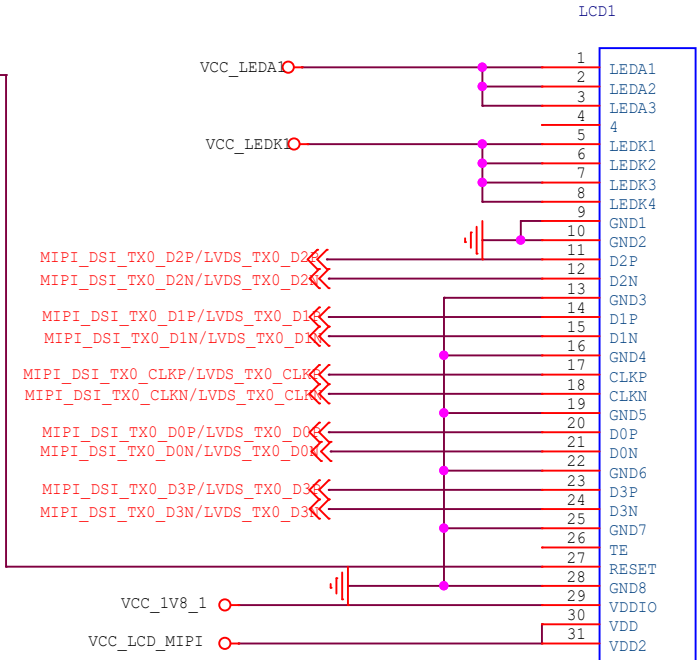
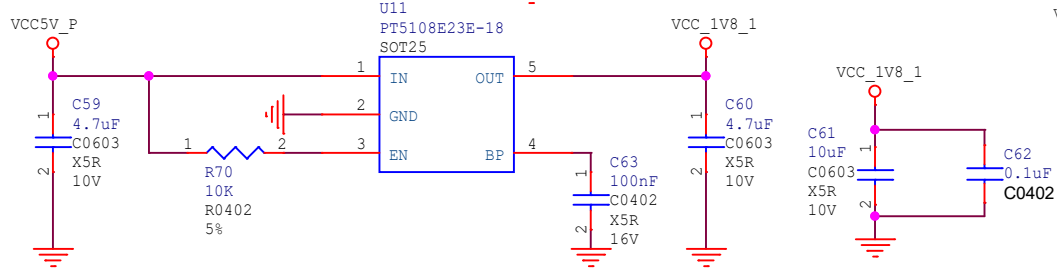
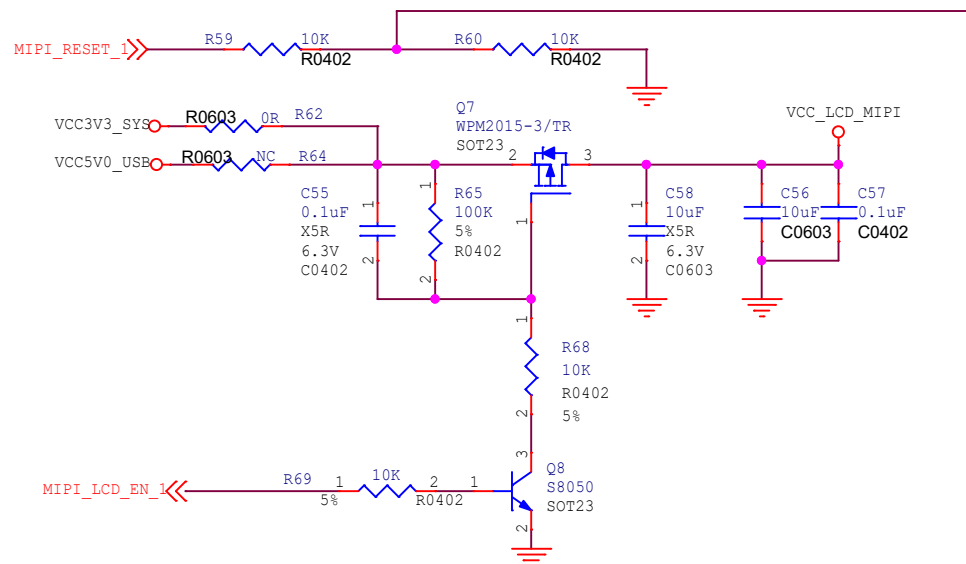
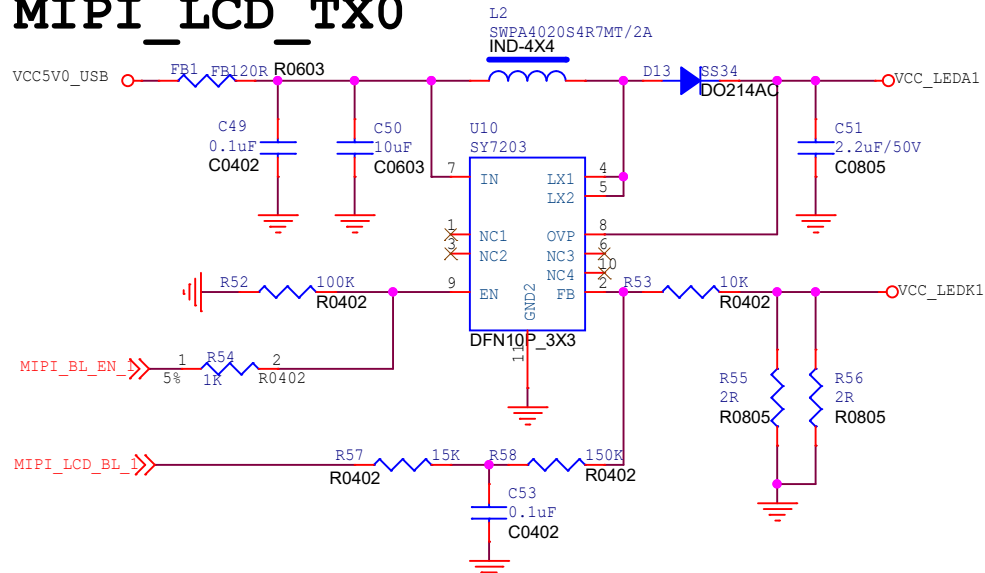

FH35C_31P_0_6SHW
FH35C_31P_0_6SHW



| | | |
|------------------------------------|--------------------------------------|----------|
| Size | Title: ROCK3 Compute Module IO Board | REV |
| A4 | Page Name: MIPI_LCD_TX0 | 1.3 |
| Date: Wednesday, December 21, 2022 | Sheet | 10 of 20 |

MIPI_CSI_RX 2Lanes

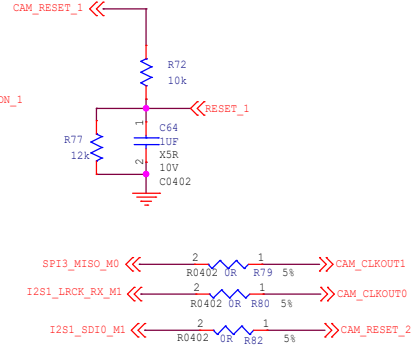
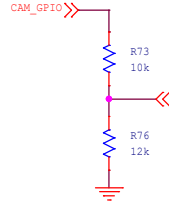
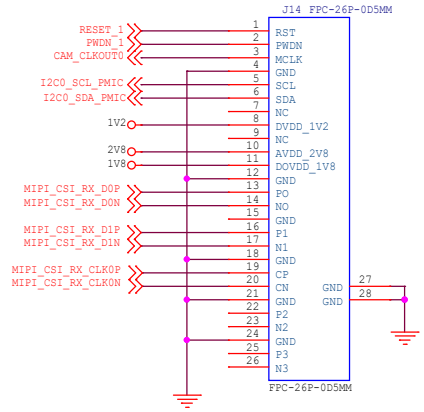

MIPI_CSI_RX 2Lanes

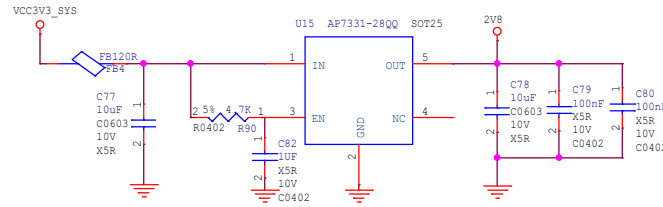
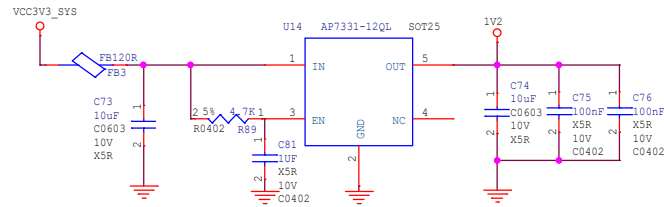
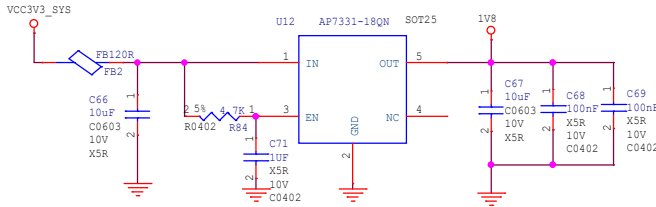
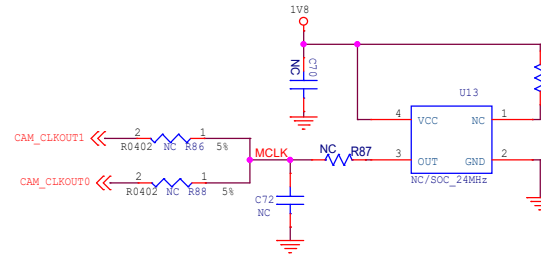
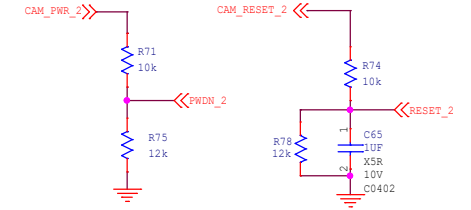
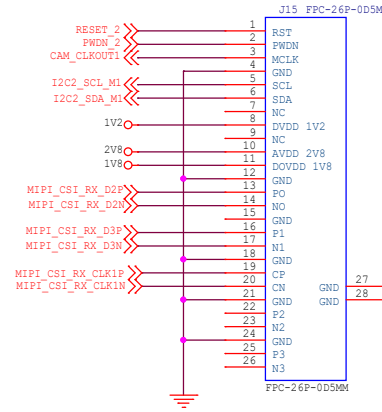

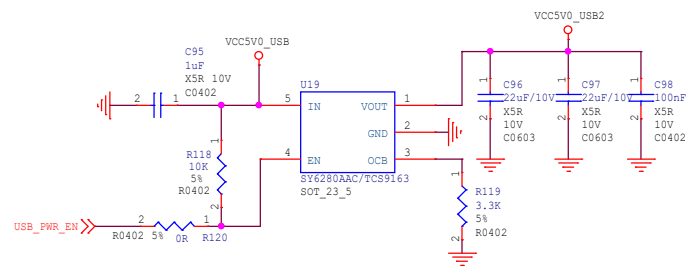
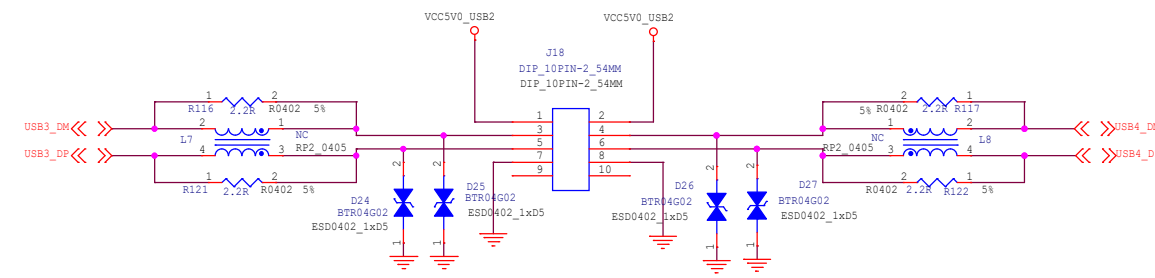
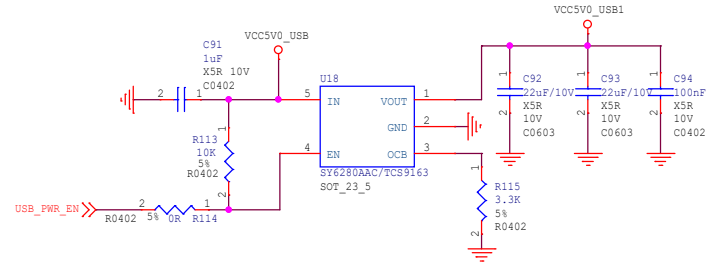
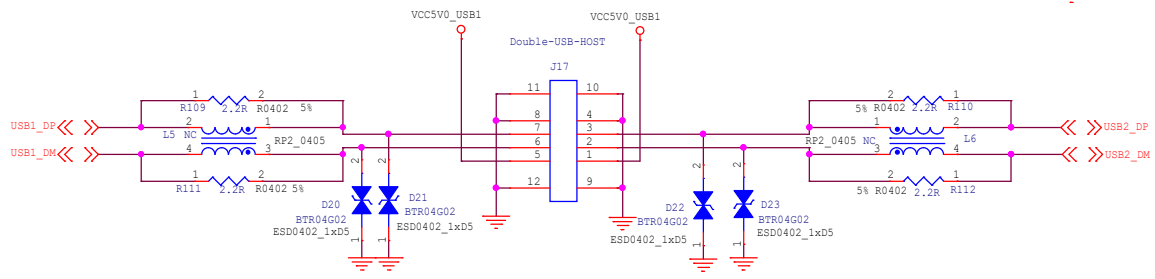
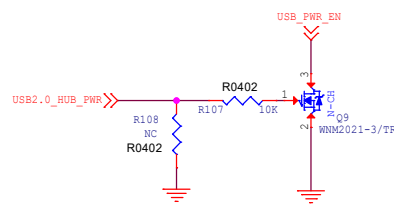
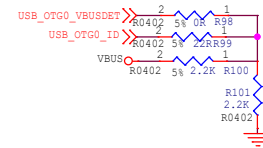
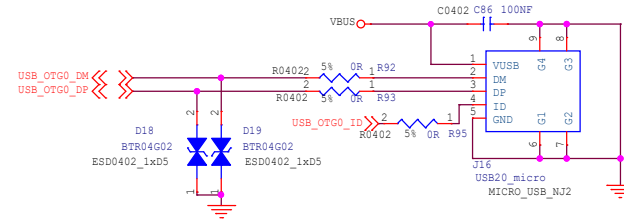
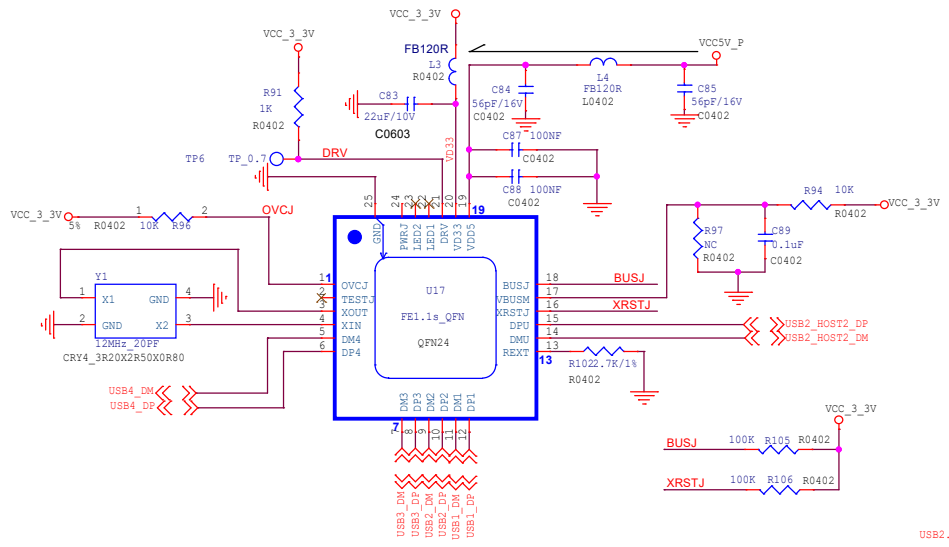

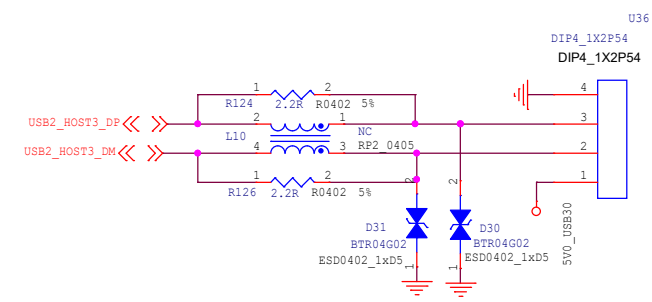
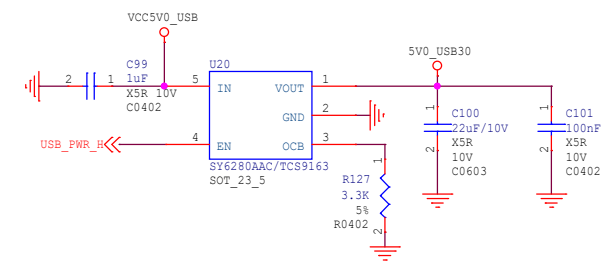
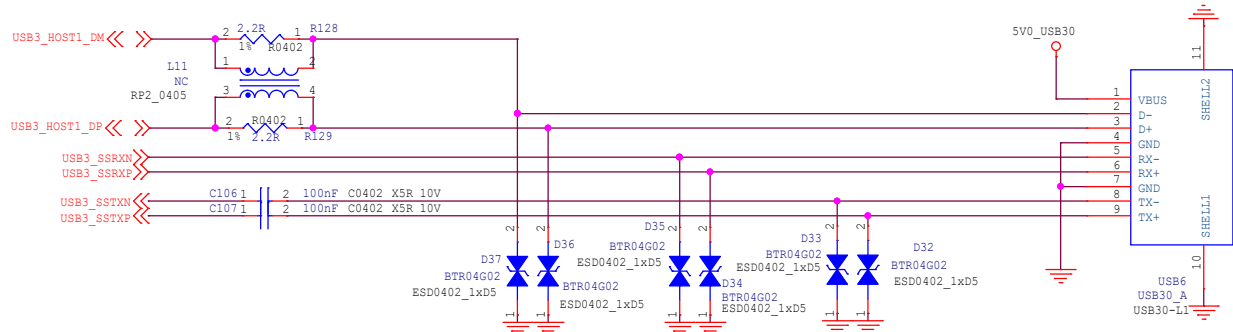

SATA3.0 Port2 And PCIe2.0 option

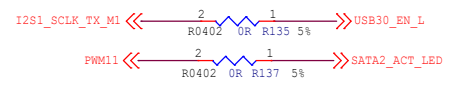
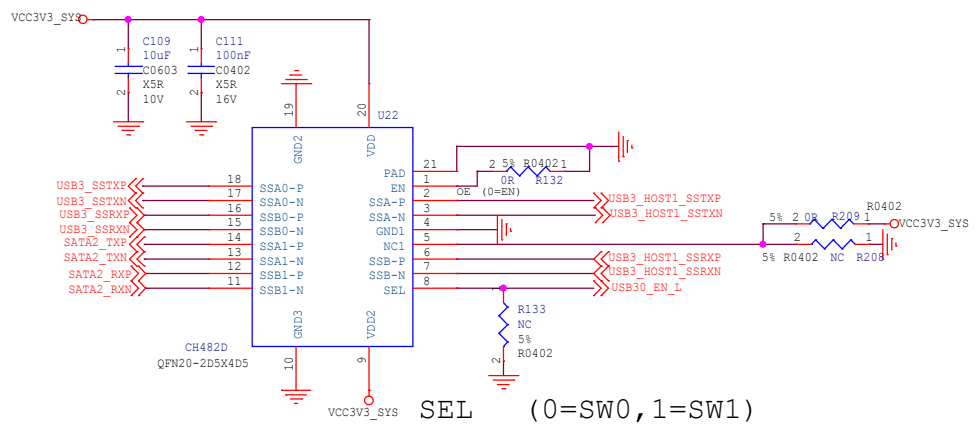
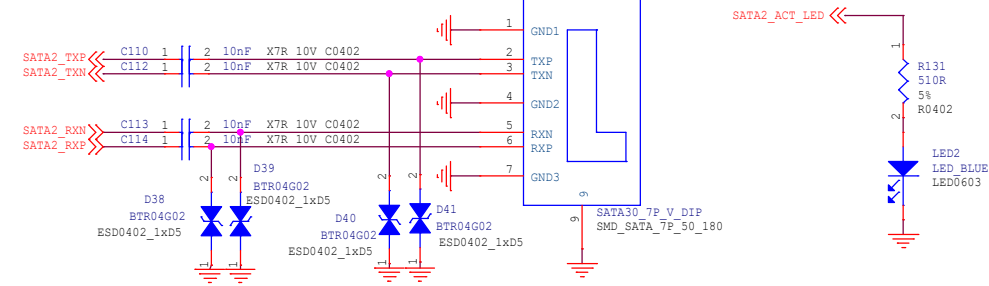



| | | |
|---|---|-----------------|
| Size | Title: ROCK3 Compute Module IO Board | REV |
| B | Page Name: USB HOST | 1.3 |
| Date: Wednesday, December 21, 2022 | | |
| Sheet | | 13 of 20 |

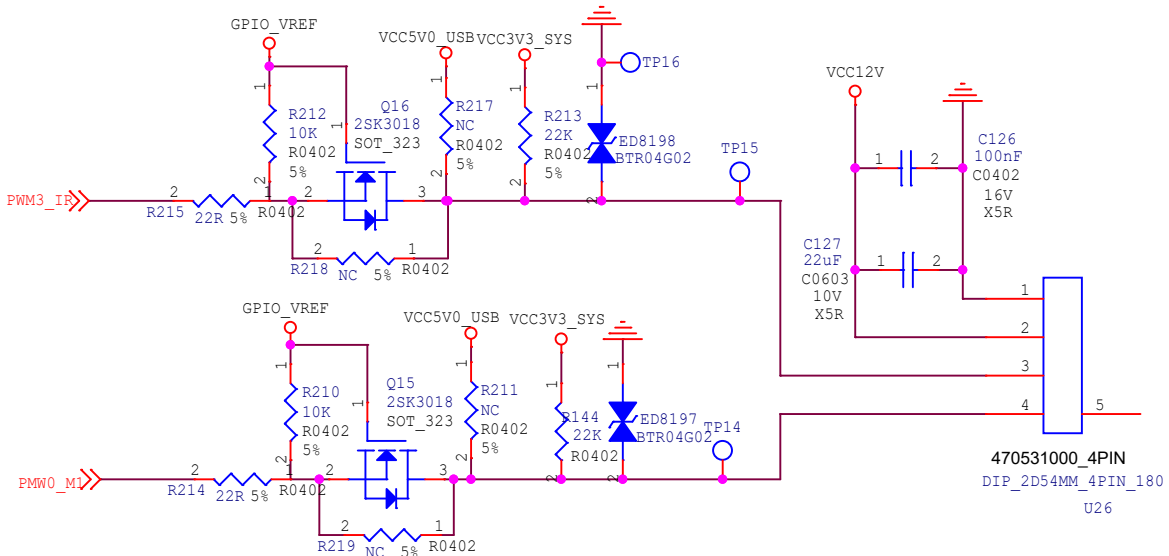
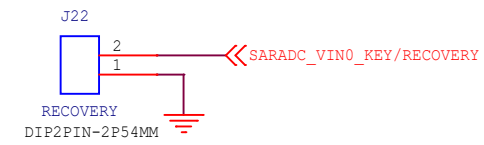
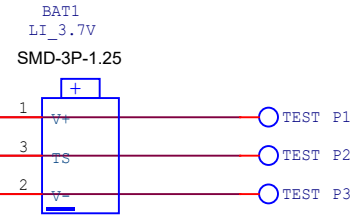
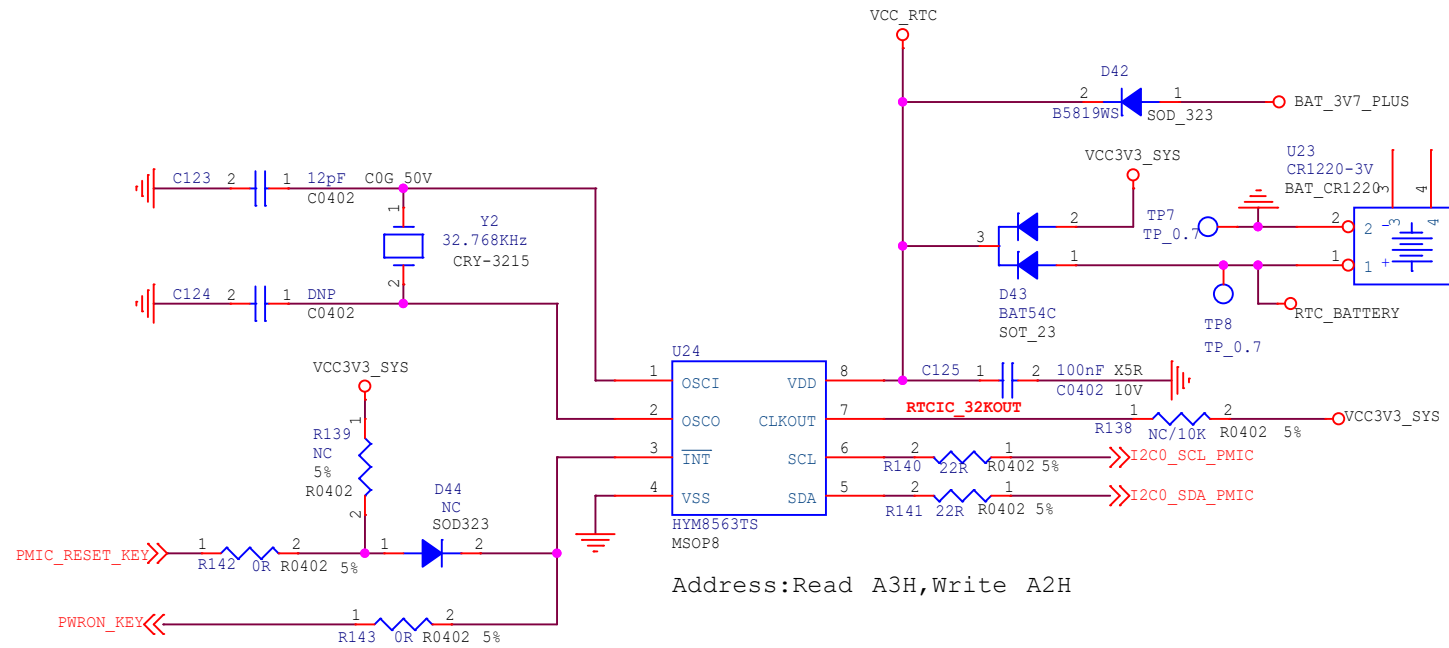

DC IN&SYSTEM Power

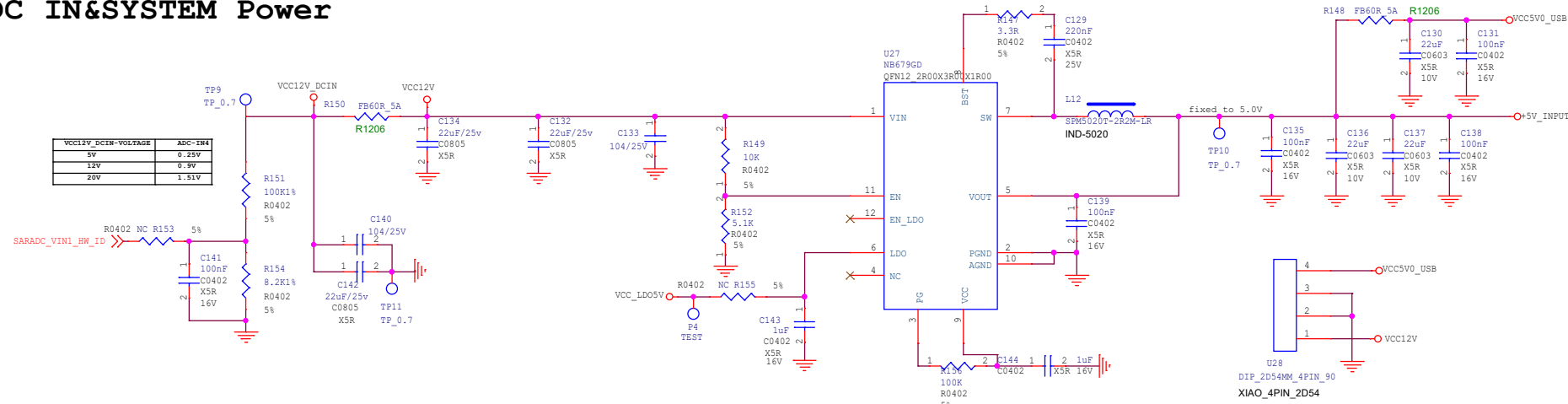

DC12V

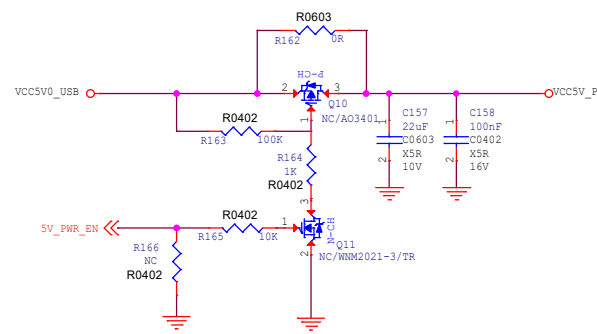
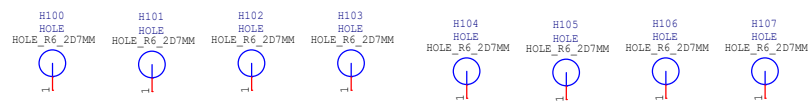
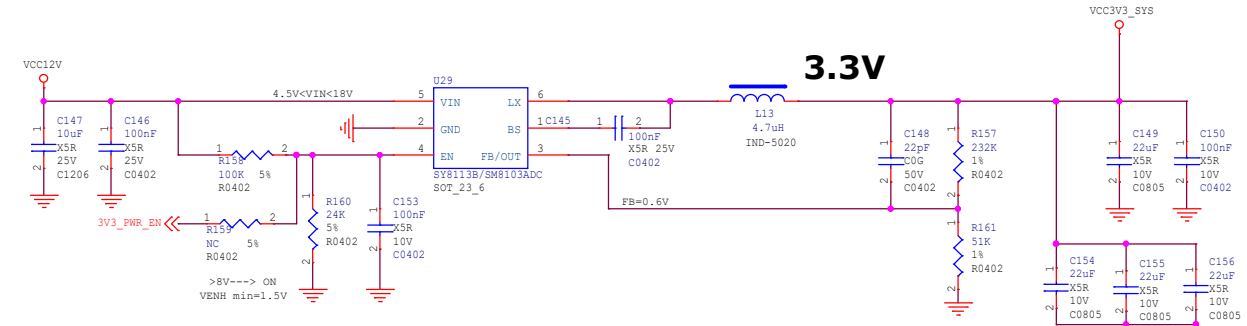
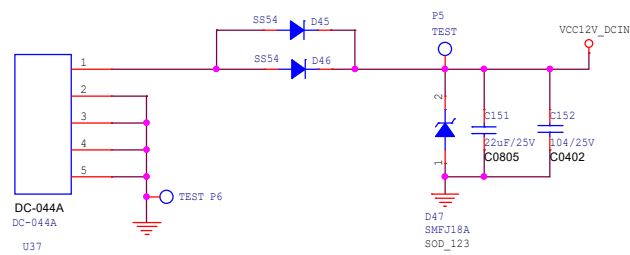

| | | | |
|-------|------------------------------|-------------------------------|----------------|
| Size | Title: | ROCK3 Compute Module IO Board | REV |
| A3 | Page Name: | Power-DC IN | 1.3 |
| Date: | Wednesday, December 21, 2022 | | Sheet 15 of 20 |

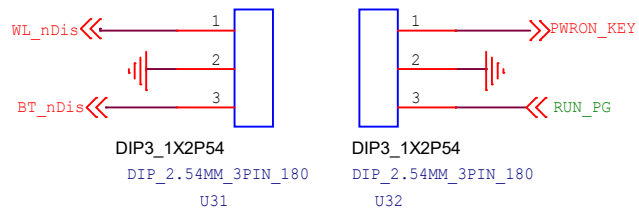
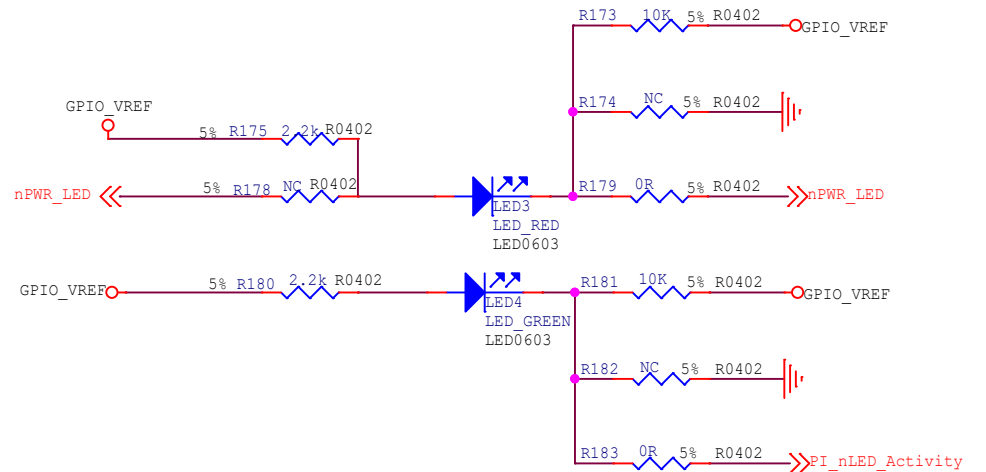
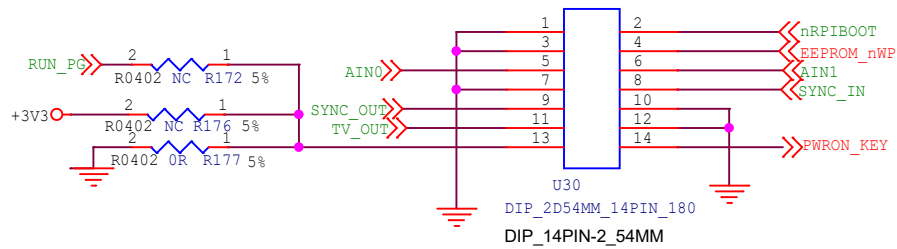
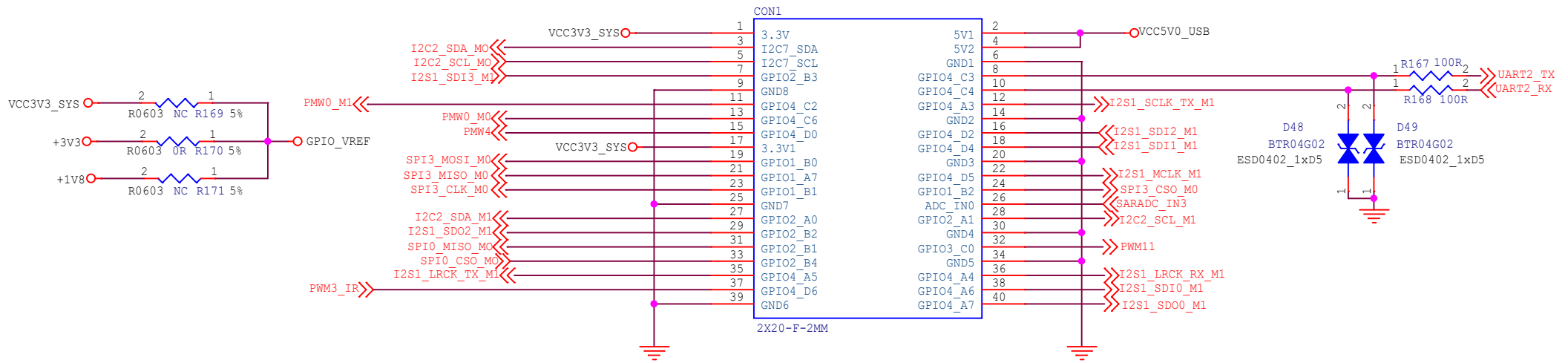



| | | |
|---|---|------------|
| Size | Title: ROCK3 Compute Module IO Board | REV |
| A4 | Page Name: 40PIN CONNECT | 1.3 |
| Date: Wednesday, December 21, 2022 | | |
| Sheet 16 of 20 | | |

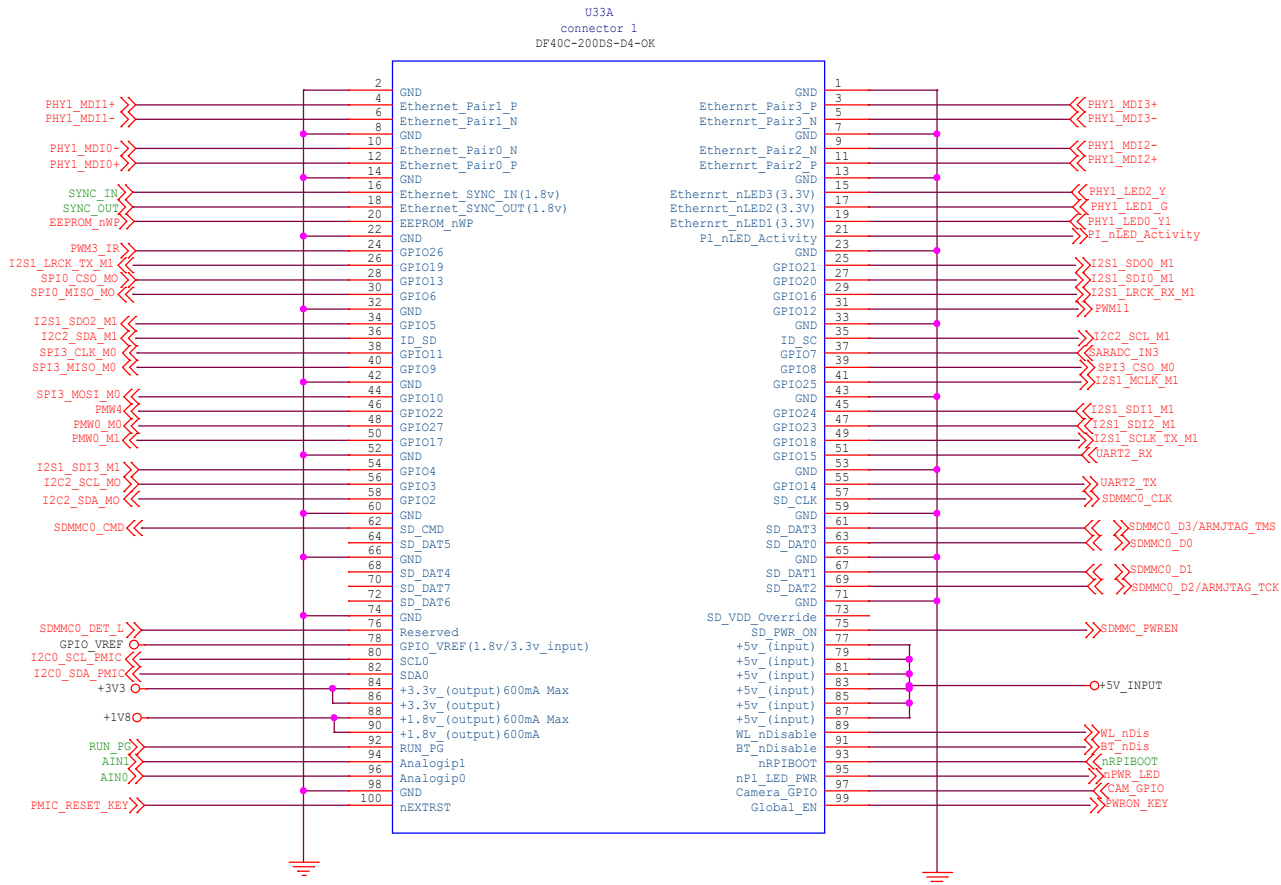

radxa

| | | |
|-------|--------------------------------------|----------------|
| Size | Title: ROCK3 Compute Module IO Board | REV |
| B | Page Name: GPIO+VCC_Connector | 1.3 |
| Date: | Wednesday, December 21, 2022 | Sheet 17 of 20 |

connector 2
U33B
DF40C-200DS-D4-0K

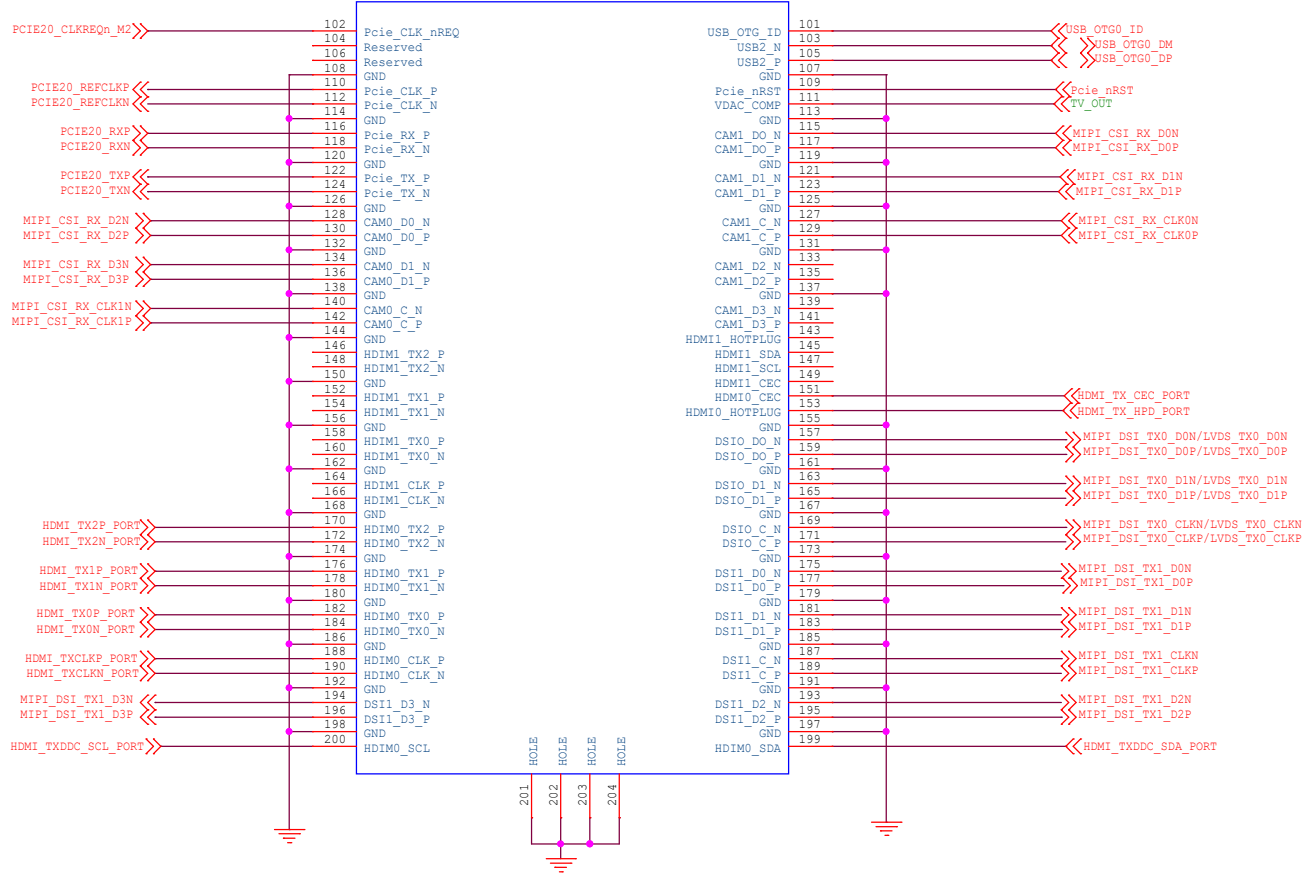

radxa

| | | |
|---|---|------------|
| Size | Title: ROCK3 Compute Module IO Board | REV |
| B | Page Name: High Speed Serial Connector | 1.3 |
| Date: Wednesday, December 21, 2022 | | |
| Sheet | | 18 of 20 |

J24
connector 3
DF40C_100DS

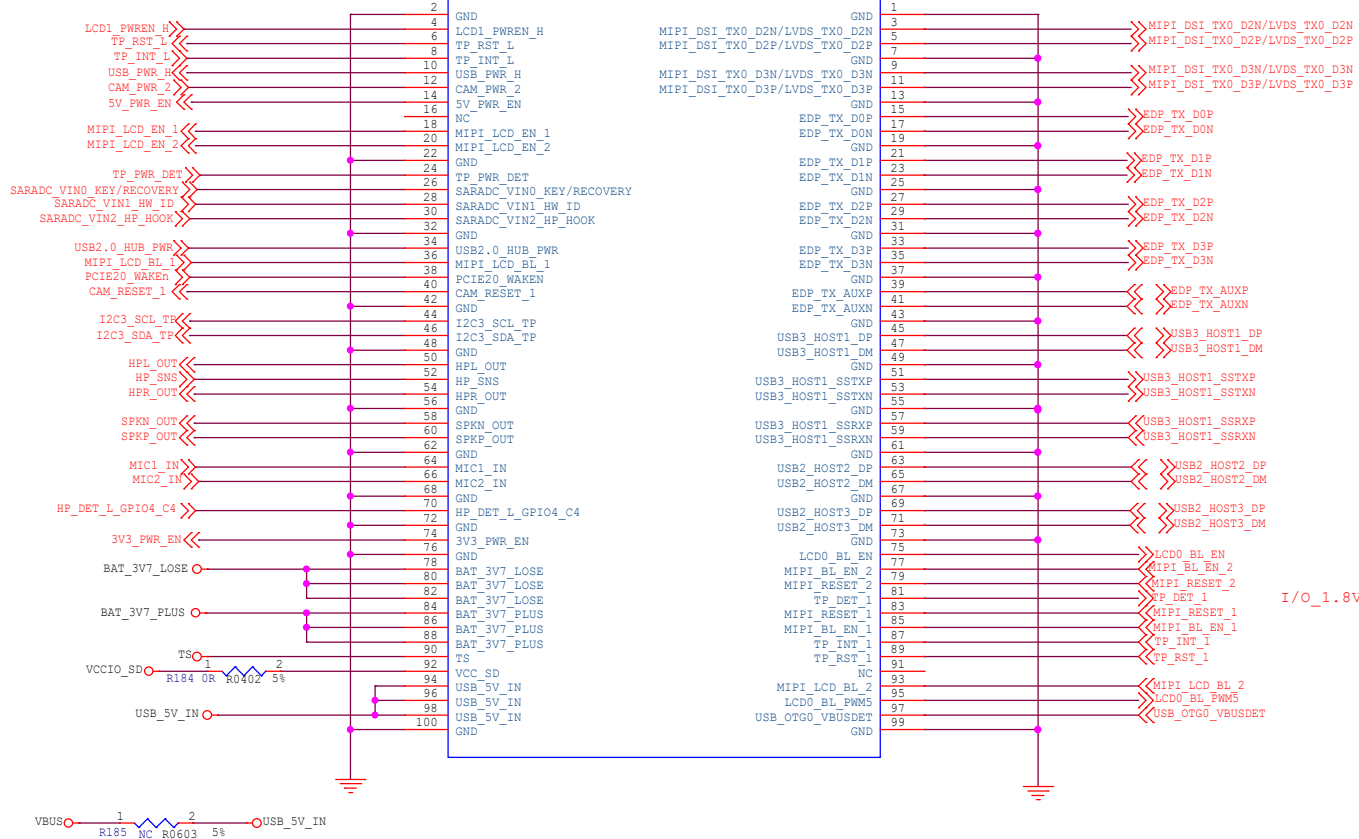

I/O_1.8V/3.3V

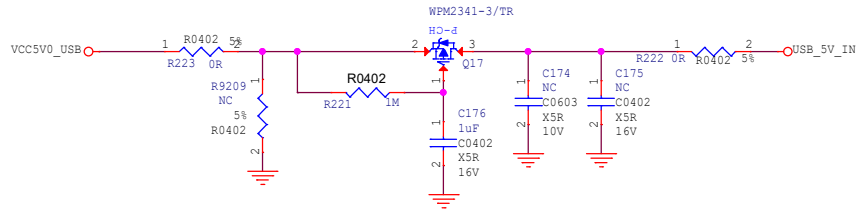



| | | |
|---|---|------------|
| Size | Title: ROCK3 Compute Module IO Board | REV |
| B | Page Name: IO_Connector | 1.3 |
| Date: Wednesday, December 21, 2022 | | |
| Sheet 19 of 20 | | |

MIPI_LCD_TX1

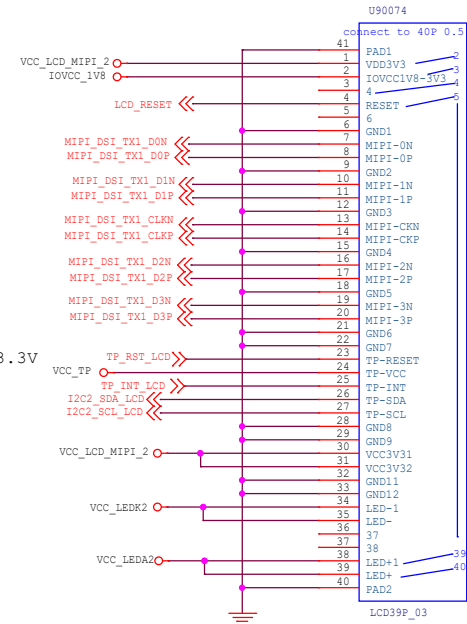
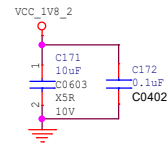
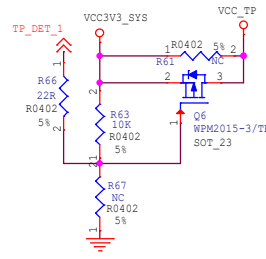
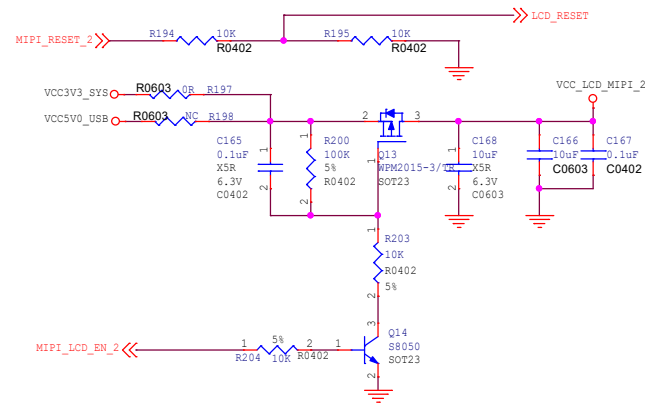
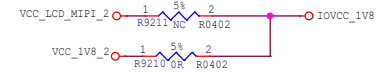
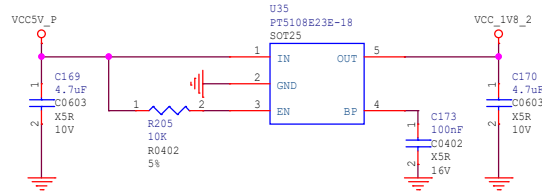
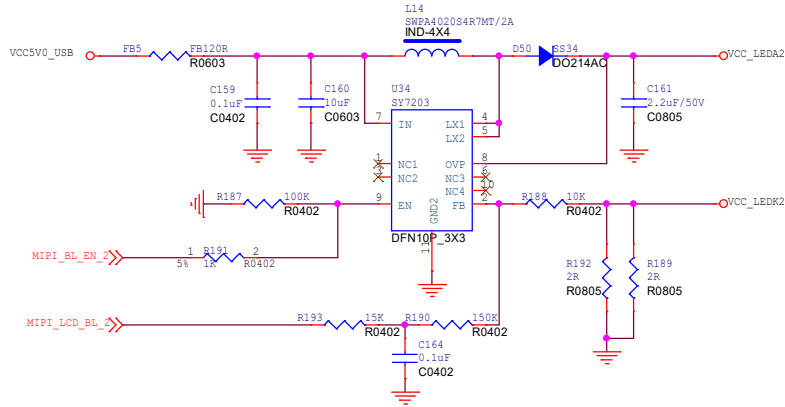

LCD_TP

