



Radxa ROCK 5C schematic

V1.1

Table of Content

- 01.cover
- 02.Index
- 03.Block Diagram
- 04.RK3588S2_Power/GND
- 05.RK3588S2_OSC/PLL/PMUIO
- 06.RK3588S2_DDR Controler
- 07.RK3588S2 Flash/SD/ TYPEC/USB
- 08.RK3588S2_SARADC/MIPI/IO
- 09.RK3588S2_MIPI Interface
- 10.RK3588S2_PCIE2/SATA/HDMI
- 11.RK3588S2 GPIO
- 12.LPDDR4/4X_200P_2X32bit
- 13.MICRO HDMI 8K
- 14.USB2/USB3 Port
- 15.USB HUB/FAN
- 16.Ethernet
- 17.MIPI LCD
- 18.SD Card/RTC
- 19.Audio ES8316
- 20.USB WIFI
- 21.EMMC FLASH/PCIE
- 22.40PIN CONNECT/KEY
- 23.Power_Ext
- 24.Power-PMIC_RK806-1
- 25.Power DC IN



Size	Title: ROCK 5C	REV
A4	Page Name: Index	1.1
Date: Tuesday, March 26, 2024		Sheet 02 of 25

5C Block Diagram

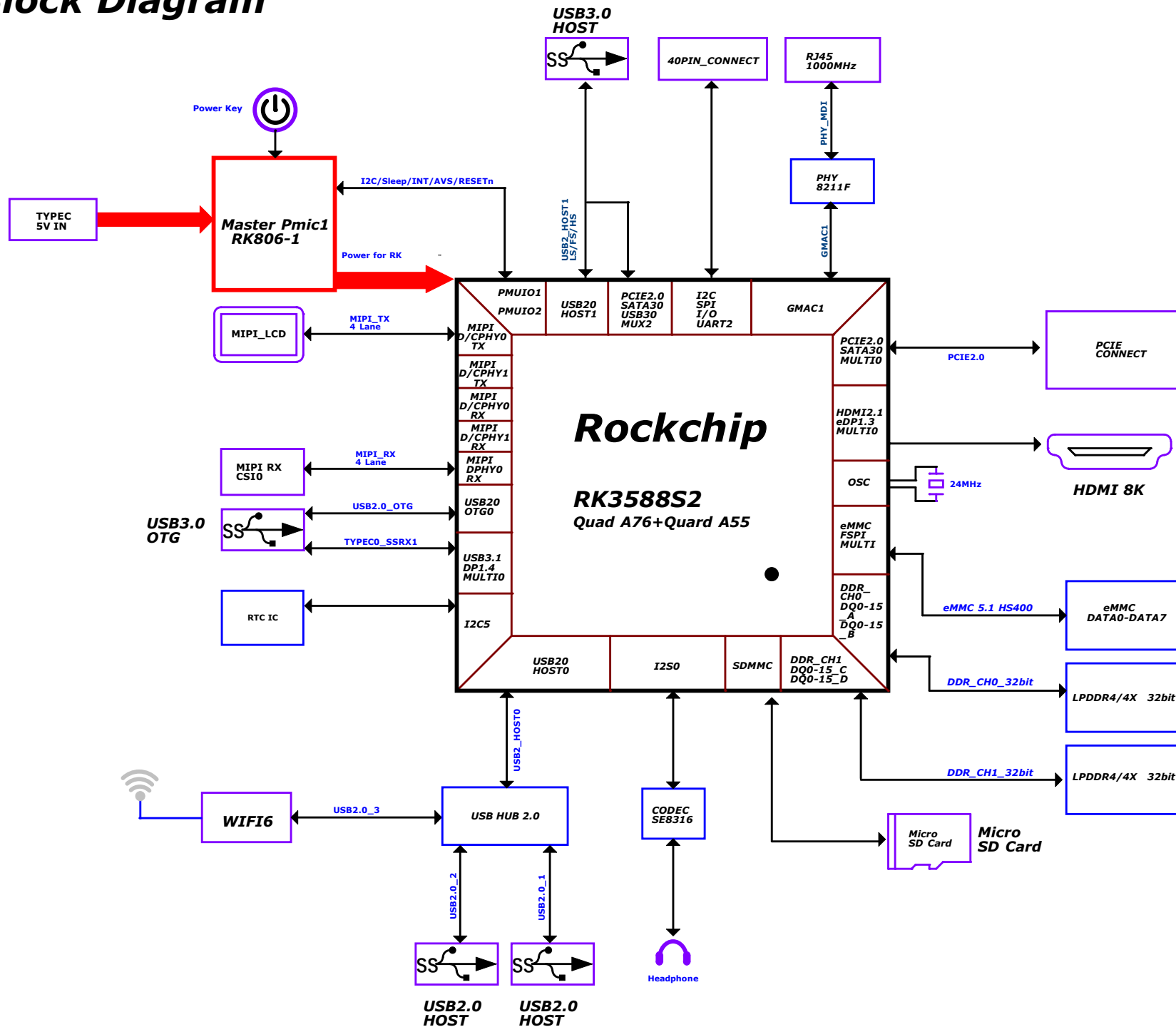

RK3588S (Power&Gnd)

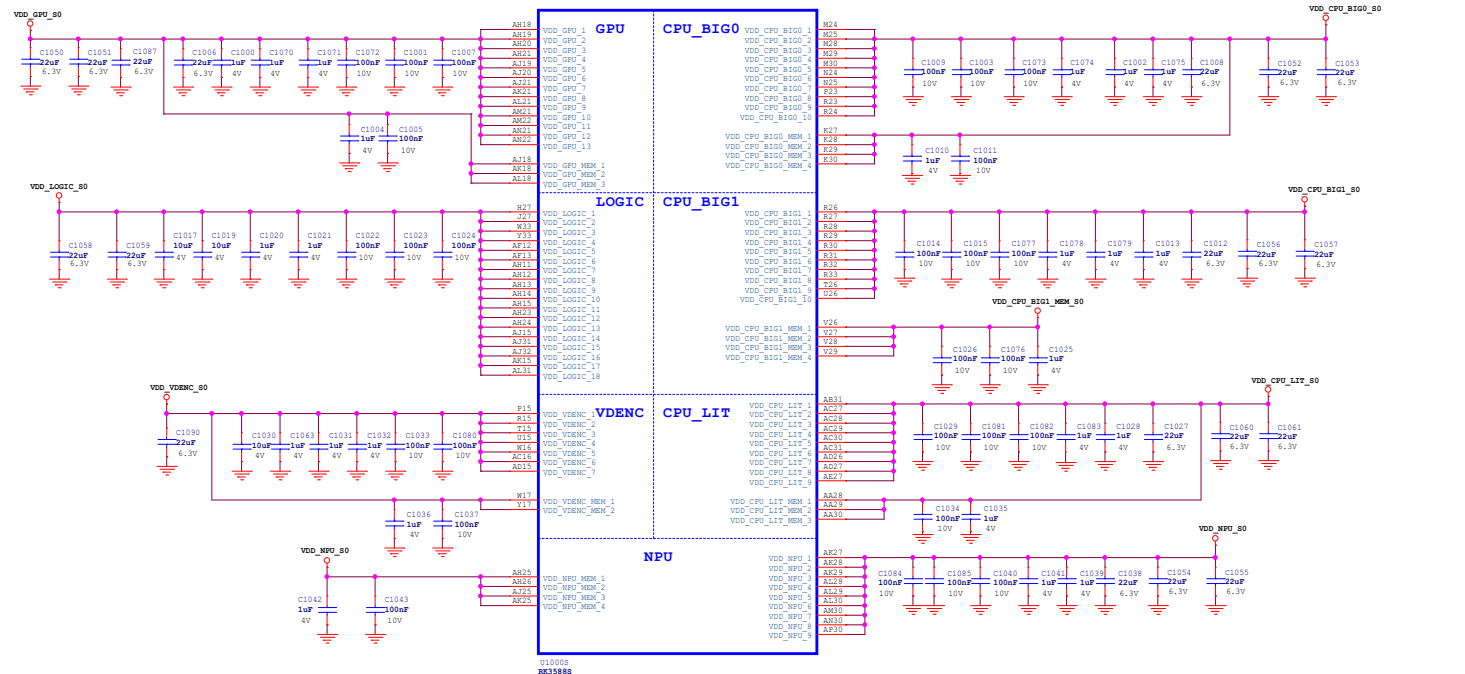

010006
RK3588S

010007			010008			010009			01000A			01000B			01000C			01000D		
A1	VSS_1	A22	VSS_101	VSS_151	A33	VSS_201	VSS_251	A44	VSS_301	VSS_351	A55	VSS_401	VSS_451	A66	VSS_501	VSS_551	A77	VSS_601	VSS_651	A88
A2	VSS_2	A23	VSS_102	VSS_152	A34	VSS_202	VSS_252	A45	VSS_302	VSS_352	A56	VSS_402	VSS_452	A67	VSS_502	VSS_552	A78	VSS_602	VSS_652	A89
A3	VSS_3	A24	VSS_103	VSS_153	A35	VSS_203	VSS_253	A46	VSS_303	VSS_353	A57	VSS_403	VSS_453	A68	VSS_503	VSS_553	A79	VSS_603	VSS_653	A90
A4	VSS_4	A25	VSS_104	VSS_154	A36	VSS_204	VSS_254	A47	VSS_304	VSS_354	A58	VSS_404	VSS_454	A69	VSS_504	VSS_554	A80	VSS_604	VSS_654	A91
A5	VSS_5	A26	VSS_105	VSS_155	A37	VSS_205	VSS_255	A48	VSS_305	VSS_355	A59	VSS_405	VSS_455	A70	VSS_505	VSS_555	A81	VSS_605	VSS_655	A92
A6	VSS_6	A27	VSS_106	VSS_156	A38	VSS_206	VSS_256	A49	VSS_306	VSS_356	A60	VSS_406	VSS_456	A71	VSS_506	VSS_556	A82	VSS_606	VSS_656	A93
B10	VSS_10	A31	VSS_107	VSS_157	A42	VSS_207	VSS_257	A53	VSS_307	VSS_357	A64	VSS_407	VSS_457	A75	VSS_507	VSS_557	A86	VSS_607	VSS_657	A97
B11	VSS_11	A32	VSS_108	VSS_158	A43	VSS_208	VSS_258	A54	VSS_308	VSS_358	A65	VSS_408	VSS_458	A76	VSS_508	VSS_558	A87	VSS_608	VSS_658	A98
B12	VSS_12	A33	VSS_109	VSS_159	A44	VSS_209	VSS_259	A55	VSS_309	VSS_359	A66	VSS_409	VSS_459	A77	VSS_509	VSS_559	A88	VSS_609	VSS_659	A99
B13	VSS_13	A34	VSS_110	VSS_160	A45	VSS_210	VSS_260	A56	VSS_310	VSS_360	A67	VSS_410	VSS_460	A78	VSS_510	VSS_560	A89	VSS_610	VSS_660	A100
B14	VSS_14	A35	VSS_111	VSS_161	A46	VSS_211	VSS_261	A57	VSS_311	VSS_361	A68	VSS_411	VSS_461	A79	VSS_511	VSS_561	A90	VSS_611	VSS_661	A101
B15	VSS_15	A36	VSS_112	VSS_162	A47	VSS_212	VSS_262	A58	VSS_312	VSS_362	A69	VSS_412	VSS_462	A80	VSS_512	VSS_562	A91	VSS_612	VSS_662	A102
B16	VSS_16	A37	VSS_113	VSS_163	A48	VSS_213	VSS_263	A59	VSS_313	VSS_363	A70	VSS_413	VSS_463	A81	VSS_513	VSS_563	A92	VSS_613	VSS_663	A103
B17	VSS_17	A38	VSS_114	VSS_164	A49	VSS_214	VSS_264	A60	VSS_314	VSS_364	A71	VSS_414	VSS_464	A82	VSS_514	VSS_564	A93	VSS_614	VSS_664	A104
B18	VSS_18	A39	VSS_115	VSS_165	A50	VSS_215	VSS_265	A61	VSS_315	VSS_365	A72	VSS_415	VSS_465	A83	VSS_515	VSS_565	A94	VSS_615	VSS_665	A105
B19	VSS_19	A40	VSS_116	VSS_166	A51	VSS_216	VSS_266	A62	VSS_316	VSS_366	A73	VSS_416	VSS_466	A84	VSS_516	VSS_566	A95	VSS_616	VSS_666	A106
B20	VSS_20	A41	VSS_117	VSS_167	A52	VSS_217	VSS_267	A63	VSS_317	VSS_367	A74	VSS_417	VSS_467	A85	VSS_517	VSS_567	A96	VSS_617	VSS_667	A107
B21	VSS_21	A42	VSS_118	VSS_168	A53	VSS_218	VSS_268	A64	VSS_318	VSS_368	A75	VSS_418	VSS_468	A86	VSS_518	VSS_568	A97	VSS_618	VSS_668	A108
B22	VSS_22	A43	VSS_119	VSS_169	A54	VSS_219	VSS_269	A65	VSS_319	VSS_369	A76	VSS_419	VSS_469	A87	VSS_519	VSS_569	A98	VSS_619	VSS_669	A109
B23	VSS_23	A44	VSS_120	VSS_170	A55	VSS_220	VSS_270	A66	VSS_320	VSS_370	A77	VSS_420	VSS_470	A88	VSS_520	VSS_570	A99	VSS_620	VSS_670	A110
B24	VSS_24	A45	VSS_121	VSS_171	A56	VSS_221	VSS_271	A67	VSS_321	VSS_371	A78	VSS_421	VSS_471	A89	VSS_521	VSS_571	A100	VSS_621	VSS_671	A111
B25	VSS_25	A46	VSS_122	VSS_172	A57	VSS_222	VSS_272	A68	VSS_322	VSS_372	A79	VSS_422	VSS_472	A90	VSS_522	VSS_572	A101	VSS_622	VSS_672	A112
B26	VSS_26	A47	VSS_123	VSS_173	A58	VSS_223	VSS_273	A69	VSS_323	VSS_373	A80	VSS_423	VSS_473	A91	VSS_523	VSS_573	A102	VSS_623	VSS_673	A113
C11	VSS_31	A52	VSS_124	VSS_174	A59	VSS_224	VSS_274	A70	VSS_324	VSS_374	A81	VSS_424	VSS_474	A92	VSS_524	VSS_574	A103	VSS_624	VSS_674	A114
C12	VSS_32	A53	VSS_125	VSS_175	A60	VSS_225	VSS_275	A71	VSS_325	VSS_375	A82	VSS_425	VSS_475	A93	VSS_525	VSS_575	A104	VSS_625	VSS_675	A115
C13	VSS_33	A54	VSS_126	VSS_176	A61	VSS_226	VSS_276	A72	VSS_326	VSS_376	A83	VSS_426	VSS_476	A94	VSS_526	VSS_576	A105	VSS_626	VSS_676	A116
C14	VSS_34	A55	VSS_127	VSS_177	A62	VSS_227	VSS_277	A73	VSS_327	VSS_377	A84	VSS_427	VSS_477	A95	VSS_527	VSS_577	A106	VSS_627	VSS_677	A117
C15	VSS_35	A56	VSS_128	VSS_178	A63	VSS_228	VSS_278	A74	VSS_328	VSS_378	A85	VSS_428	VSS_478	A96	VSS_528	VSS_578	A107	VSS_628	VSS_678	A118
C16	VSS_36	A57	VSS_129	VSS_179	A64	VSS_229	VSS_279	A75	VSS_329	VSS_379	A86	VSS_429	VSS_479	A97	VSS_529	VSS_579	A108	VSS_629	VSS_679	A119
C17	VSS_37	A58	VSS_130	VSS_180	A65	VSS_230	VSS_280	A76	VSS_330	VSS_380	A87	VSS_430	VSS_480	A98	VSS_530	VSS_580	A109	VSS_630	VSS_680	A120
C18	VSS_38	A59	VSS_131	VSS_181	A66	VSS_231	VSS_281	A77	VSS_331	VSS_381	A88	VSS_431	VSS_481	A99	VSS_531	VSS_581	A110	VSS_631	VSS_681	A121
C19	VSS_39	A60	VSS_132	VSS_182	A67	VSS_232	VSS_282	A78	VSS_332	VSS_382	A89	VSS_432	VSS_482	A100	VSS_532	VSS_582	A111	VSS_632	VSS_682	A122
C20	VSS_40	A61	VSS_133	VSS_183	A68	VSS_233	VSS_283	A79	VSS_333	VSS_383	A90	VSS_433	VSS_483	A101	VSS_533	VSS_583	A112	VSS_633	VSS_683	A123
C21	VSS_41	A62	VSS_134	VSS_184	A69	VSS_234	VSS_284	A80	VSS_334	VSS_384	A91	VSS_434	VSS_484	A102	VSS_534	VSS_584	A113	VSS_634	VSS_684	A124
C22	VSS_42	A63	VSS_135	VSS_185	A70	VSS_235	VSS_285	A81	VSS_335	VSS_385	A92	VSS_435	VSS_485	A103	VSS_535	VSS_585	A114	VSS_635	VSS_685	A125
C23	VSS_43	A64	VSS_136	VSS_186	A71	VSS_236	VSS_286	A82	VSS_336	VSS_386	A93	VSS_436	VSS_486	A104	VSS_536	VSS_586	A115	VSS_636	VSS_686	A126
C24	VSS_44	A65	VSS_137	VSS_187	A72	VSS_237	VSS_287	A83	VSS_337	VSS_387	A94	VSS_437	VSS_487	A105	VSS_537	VSS_587	A116	VSS_637	VSS_687	A127
C25	VSS_45	A66	VSS_138	VSS_188	A73	VSS_238	VSS_288	A84	VSS_338	VSS_388	A95	VSS_438	VSS_488	A106	VSS_538	VSS_588	A117	VSS_638	VSS_688	A128
C26	VSS_46	A67	VSS_139	VSS_189	A74	VSS_239	VSS_289	A85	VSS_339	VSS_389	A96	VSS_439	VSS_489	A107	VSS_539	VSS_589	A118	VSS_639	VSS_689	A129
C27	VSS_47	A68	VSS_140	VSS_190	A75	VSS_240	VSS_290	A86	VSS_340	VSS_390	A97	VSS_440	VSS_490	A108	VSS_540	VSS_590	A119	VSS_640	VSS_690	A130
C28	VSS_48	A69	VSS_141	VSS_191	A76	VSS_241	VSS_291	A87	VSS_341	VSS_391	A98	VSS_441	VSS_491	A109	VSS_541	VSS_591	A120	VSS_641	VSS_691	A131
C29	VSS_49	A70	VSS_142	VSS_192	A77	VSS_242	VSS_292	A88	VSS_342	VSS_392	A99	VSS_442	VSS_492	A110	VSS_542	VSS_592	A121	VSS_642	VSS_692	A132
C30	VSS_50	A71	VSS_143	VSS_193	A78	VSS_243	VSS_293	A89	VSS_343	VSS_393	A100	VSS_443	VSS_493	A111	VSS_543	VSS_593	A122	VSS_643	VSS_693	A133
C31	VSS_51	A72	VSS_144	VSS_194	A79	VSS_244	VSS_294	A90	VSS_344	VSS_394	A101	VSS_444	VSS_494	A112	VSS_544	VSS_594	A123	VSS_644	VSS_694	A134
C32	VSS_52	A73	VSS_145	VSS_195	A80	VSS_245	VSS_295	A91	VSS_345	VSS_395	A102	VSS_445	VSS_495	A113	VSS_545	VSS_595	A124	VSS_645	VSS_695	A135
C33	VSS_53	A74	VSS_146	VSS_196	A81	VSS_246	VSS_296	A92	VSS_346	VSS_396	A103	VSS_446	VSS_496	A114	VSS_546	VSS_596	A125	VSS_646	VSS_696	A136
C34	VSS_54	A75	VSS_147	VSS_197	A82	VSS_247	VSS_297	A93	VSS_347	VSS_397	A104	VSS_447	VSS_497	A115	VSS_547	VSS_597	A126	VSS_647	VSS_697	A137
C35	VSS_55	A76	VSS_148	VSS_198	A83	VSS_248	VSS_298	A94	VSS_348	VSS_398	A105	VSS_448	VSS_498	A116	VSS_548	VSS_598	A127	VSS_648	VSS_698	A138
C36	VSS_56	A77	VSS_149	VSS_199	A84	VSS_249	VSS_299	A95	VSS_349	VSS_399	A106	VSS_449	VSS_499	A117	VSS_549	VSS_599	A128	VSS_649	VSS_699	A139
C37	VSS_57	A78	VSS_150	VSS_200	A85	VSS_250	VSS_300	A96	VSS_350	VSS_400	A107	VSS_450	VSS_500	A118	VSS_550	VSS_600	A129	VSS_650	VSS_700	A140

Size	Title: ROCK 6C	REV
A2	Page Name: RK3588S2 Power/GND	1.1
Date: Tuesday, March 26, 2024	Sheet: 04	of 25

RK3588S (OSC/PLL/PMUIO1)

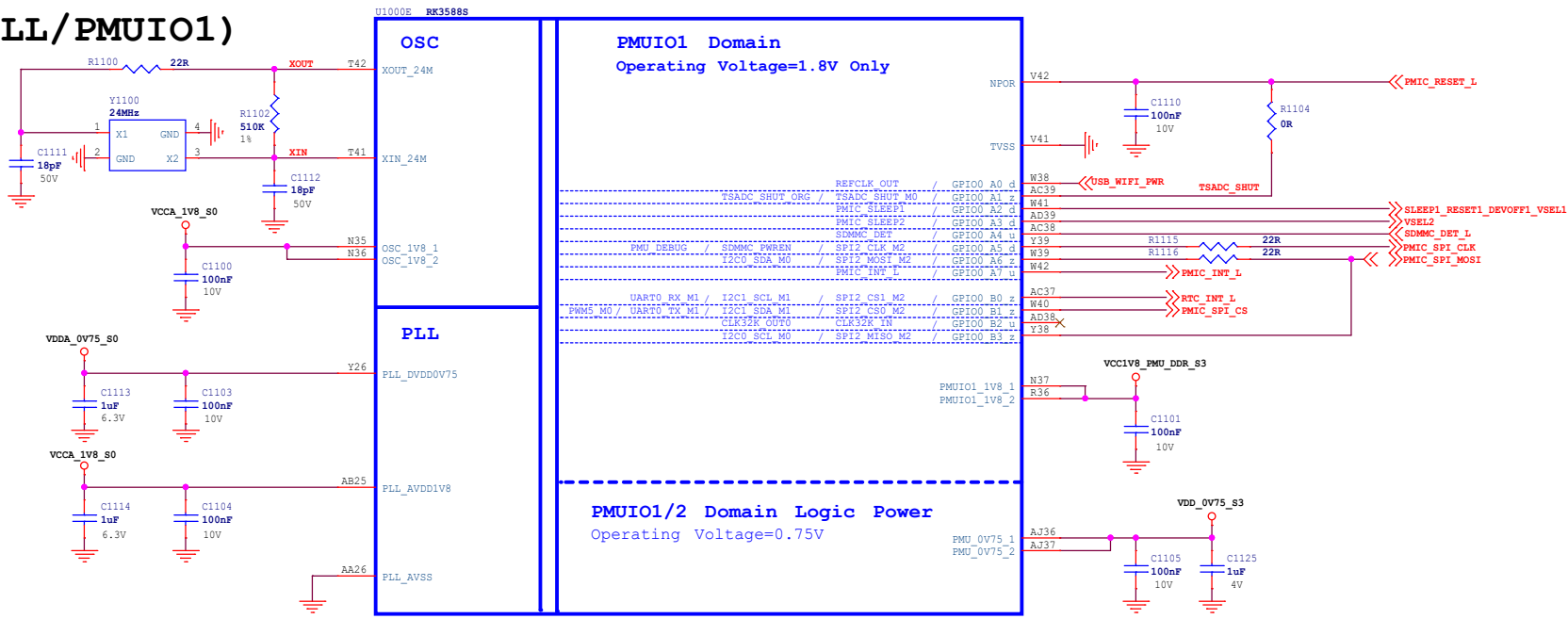

RK3588S (PMUIO2)

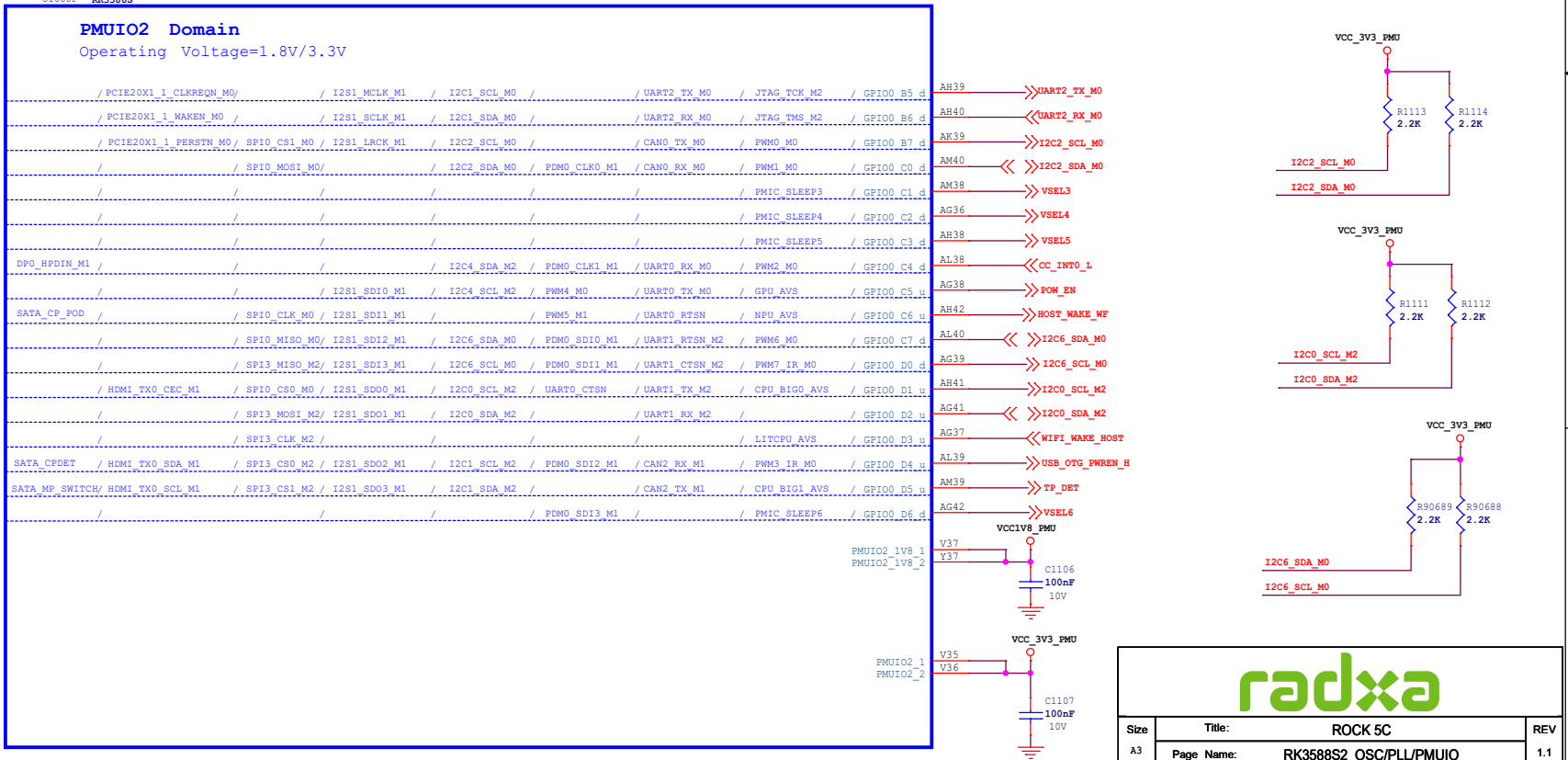



Size	Title: ROCK 5C	REV
a3	Page Name: RK3588S2_OSC/PLL/PMUIO	1.1
Date: Tuesday, March 26, 2024	Sheet 05 of 25	

RK3588S (DDR PHY)

U1000A RK3588S

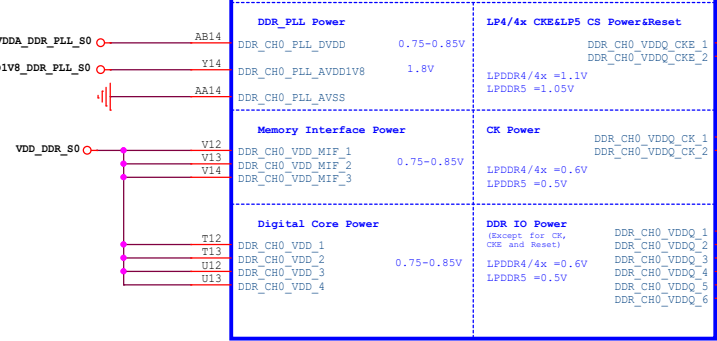
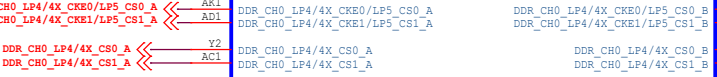
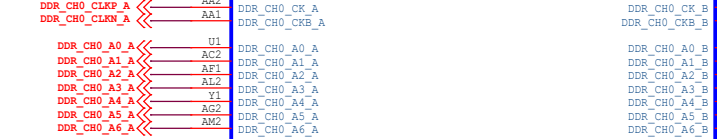
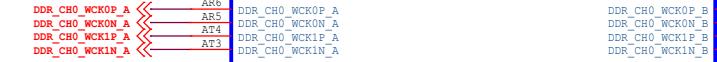
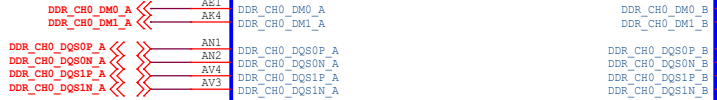
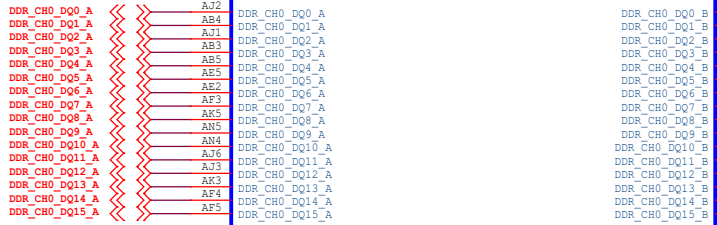

U1000B RK3588S

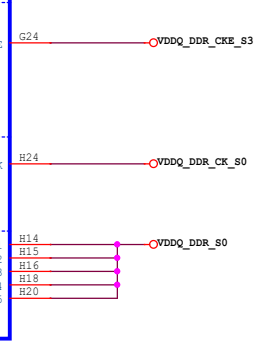
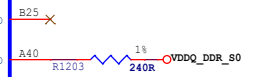
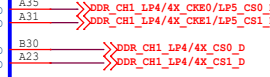
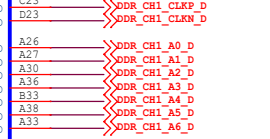
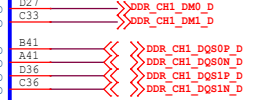
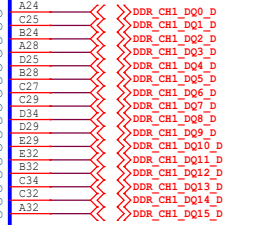
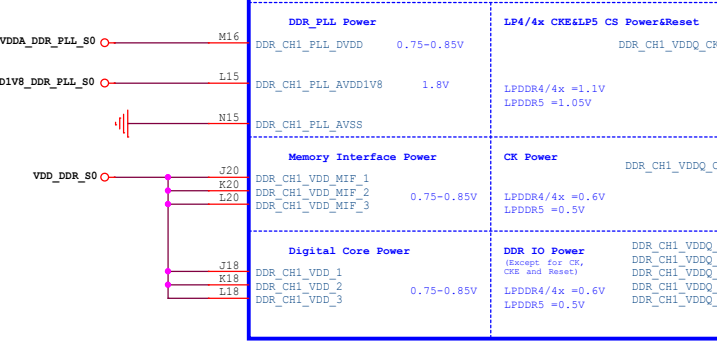
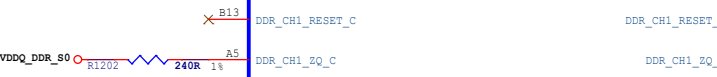
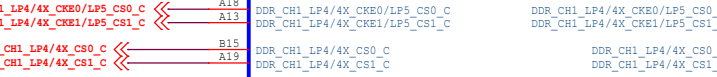
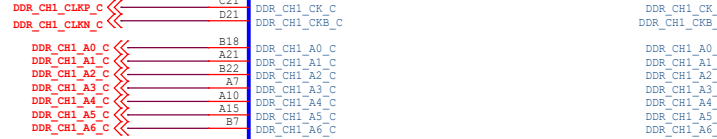
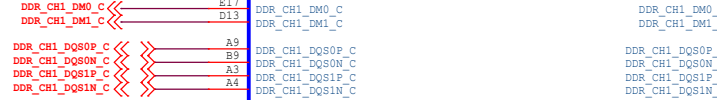
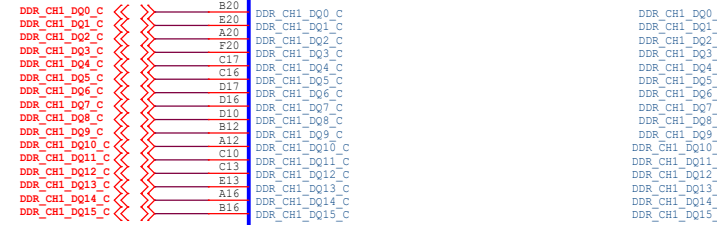

DDR FILTER

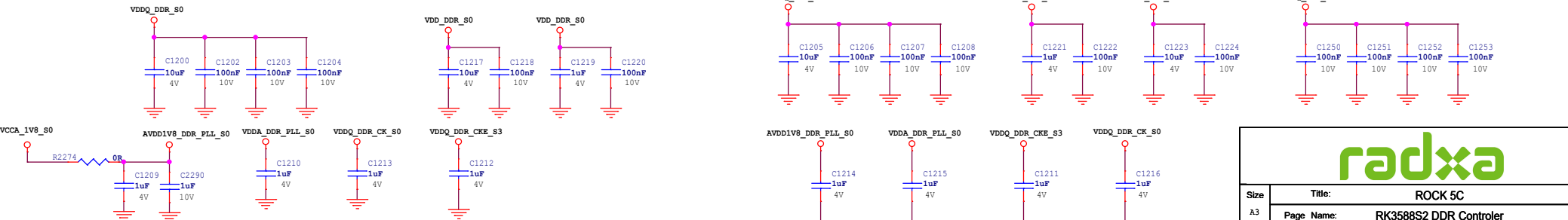

Size	Title:	ROCK 5C	REV
A3	Page Name:	RK3588S2 DDR Controller	1.1
Date:	Tuesday, March 26, 2024	Sheet	06 of 25

RK3588S (EMMCIO Domain)

RK3588S (VCCIO2 Domain)

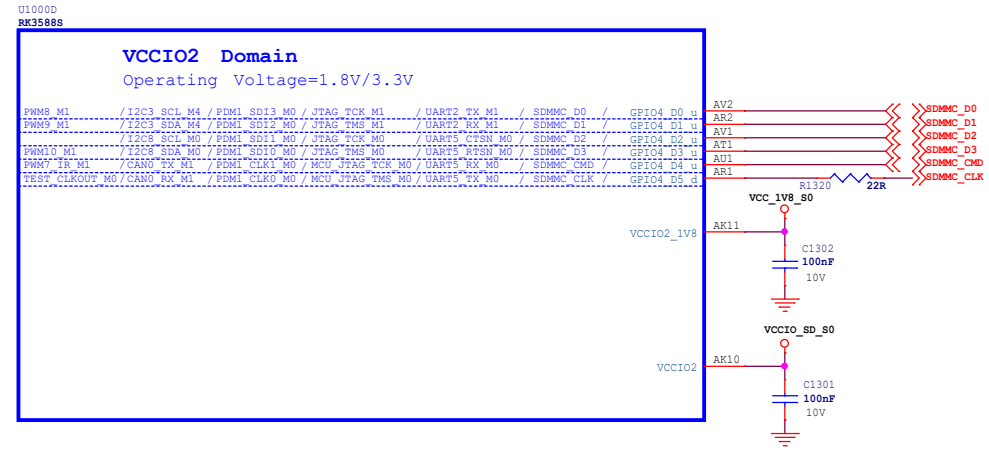
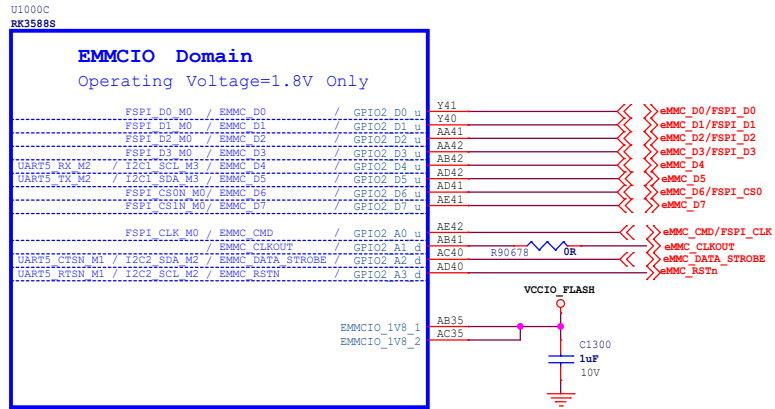

RK3588S (USB3.0/DP1.4)

RK3588S (USB2.0)

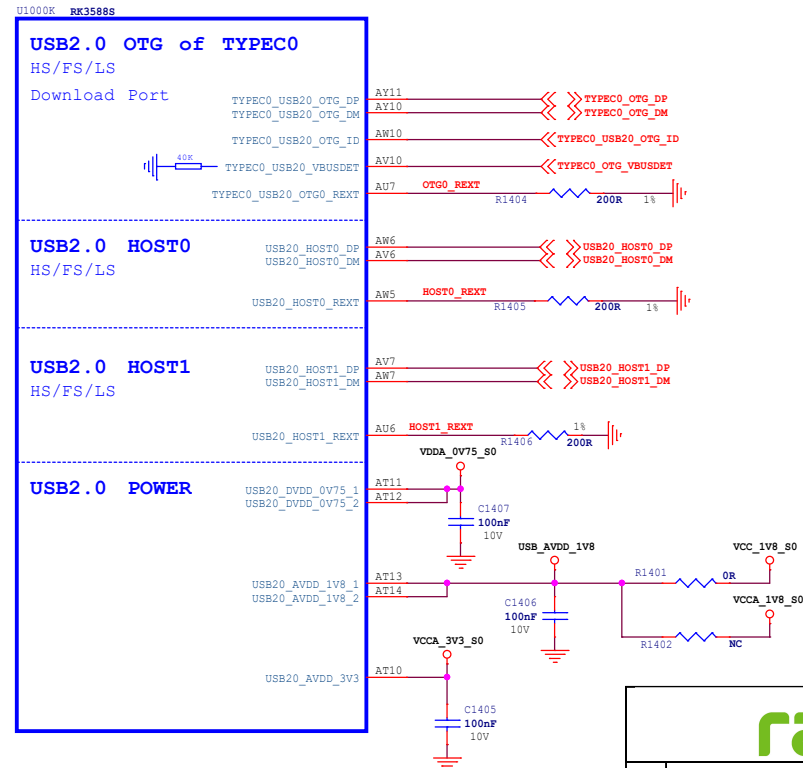
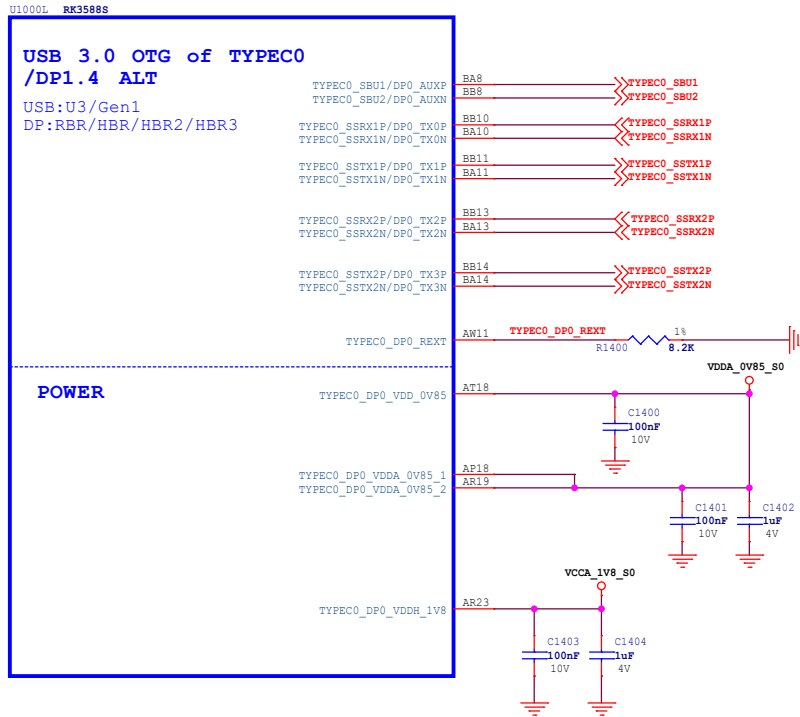

RK3588S (SARADC/OTP/TSADC)

- ⟨ SARADC_VIN1_KEY/RECOVERY
- ⟨ SARADC_VIN2
- ⟨ SARADC_VIN3_HP_HOOK
- ⟨ SARADC_VIN0_BOOT

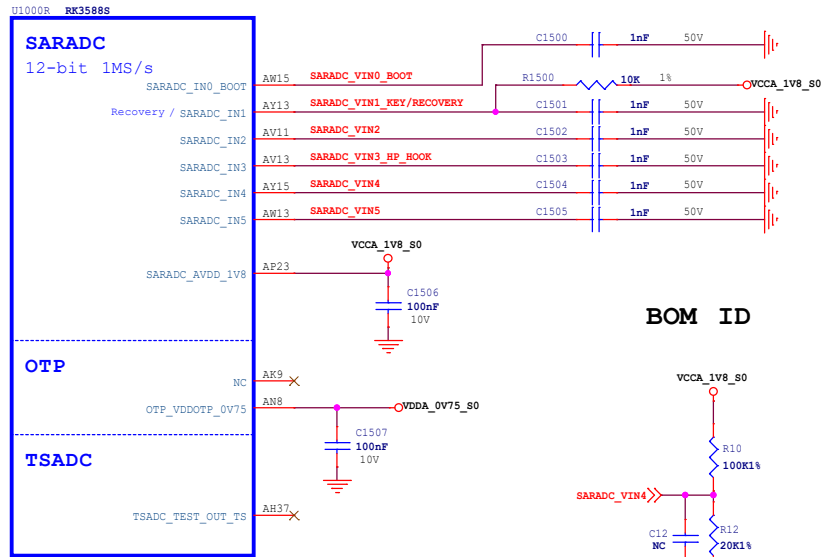

BOM ID

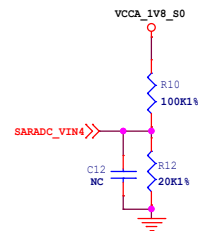

BOOT MODE CONFIG

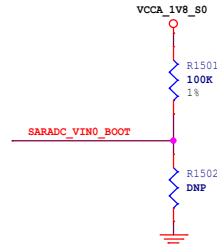

BOARD ID

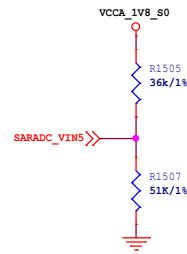

RK3588S (MIPI_DPHY CSI0 RX)

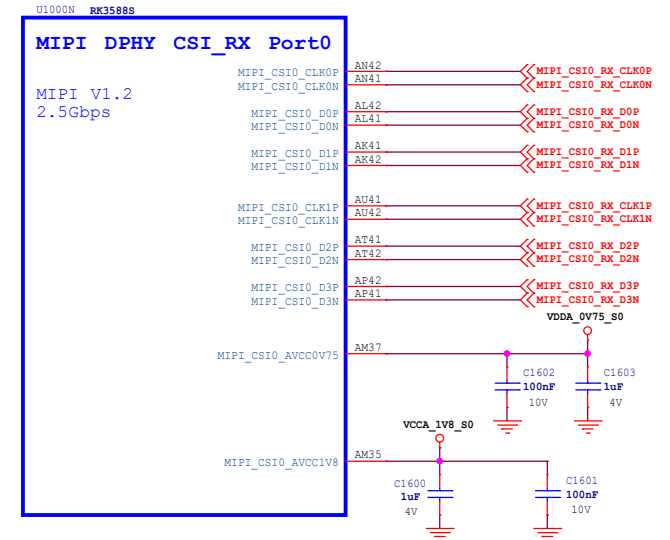

RK3588S (VCCIO1 Domain)

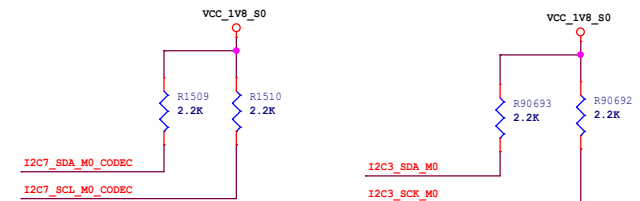
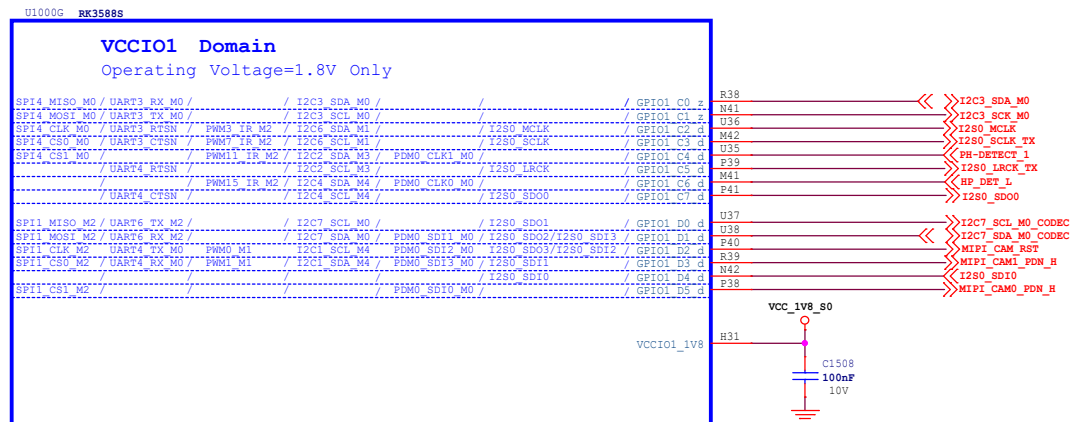

RK3588S (MIPI_D/C PHY1)

RK3588S (MIPI_D/C PHY0)

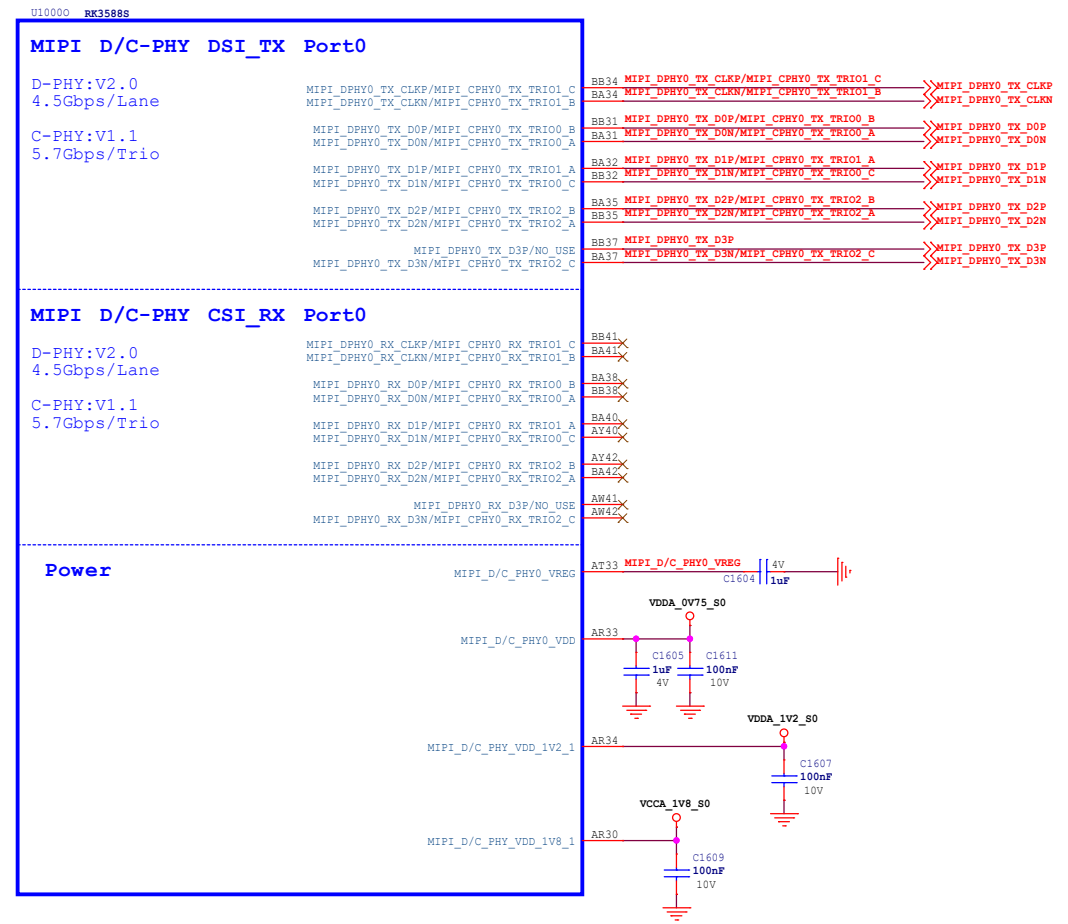
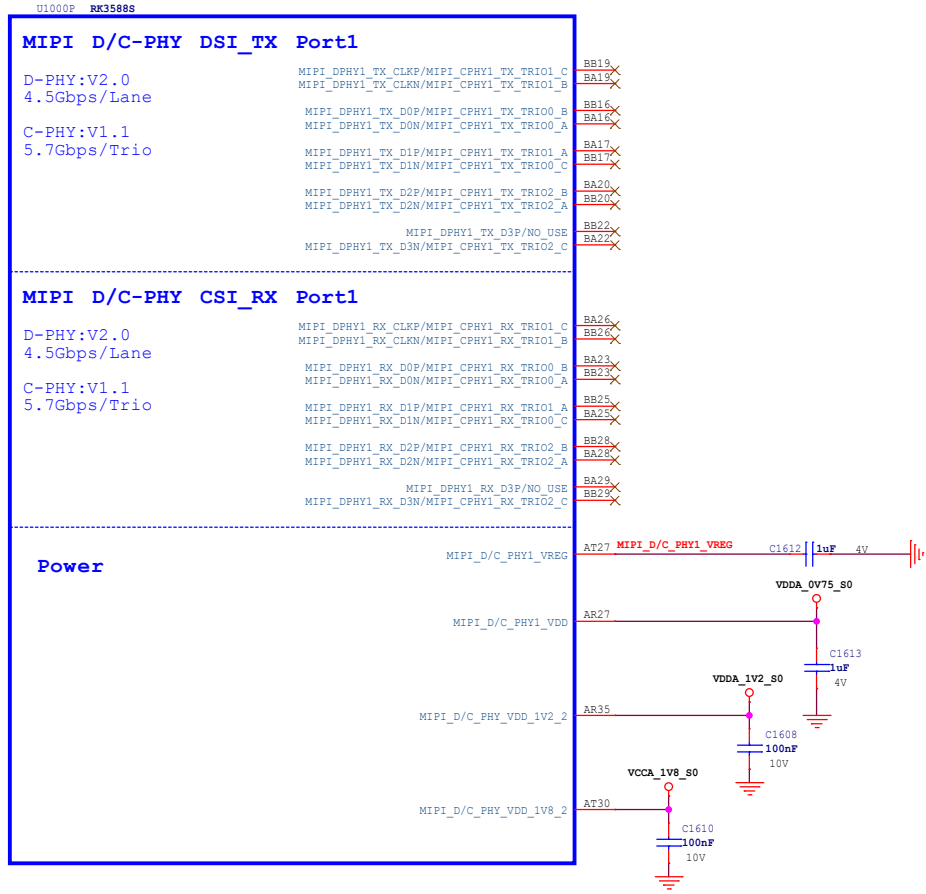

RK3588S (PCIE20/SATA30/USB30)

RK3588S (HDMI2.1 TX/eDP1.3 TX)

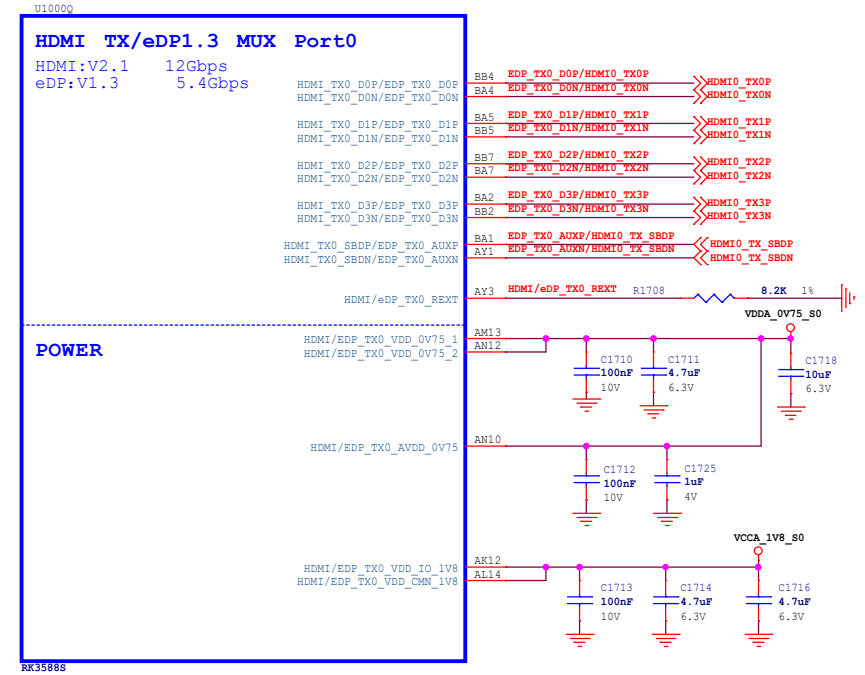
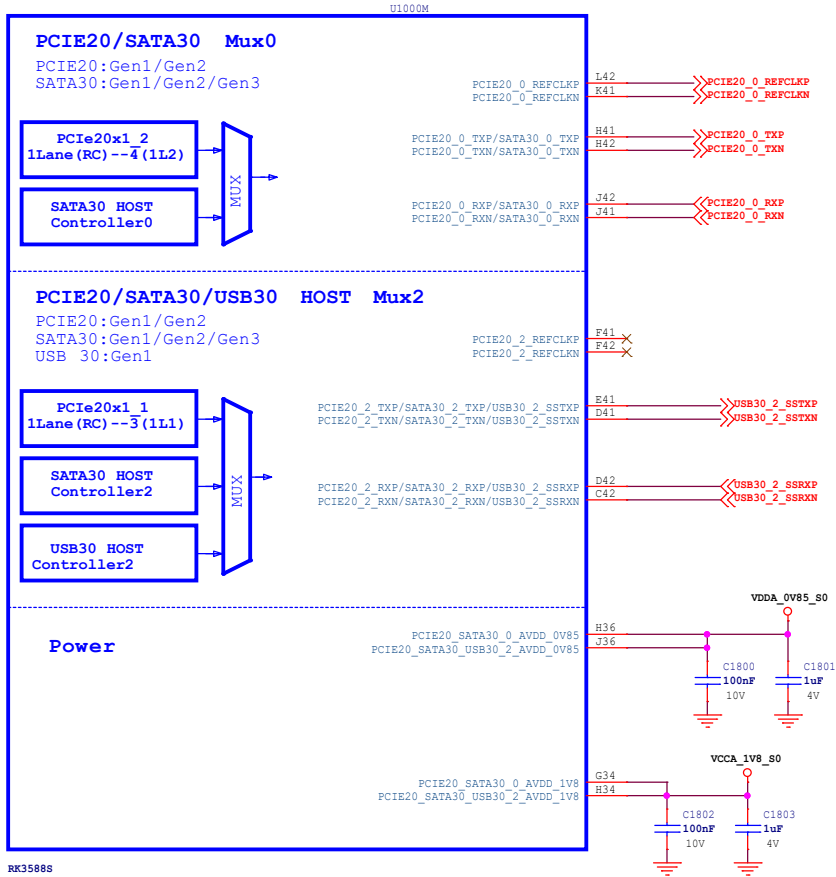

RK3588S

RK3588S



Size	Title: ROCK 5C	REV
A3	Page Name: RK3588S2 PCIE2/SATA/HDMI	1.1
Date: Tuesday, March 26, 2024	Sheet 10 of 25	

RK3588S (VCCIO4 Domain)

RK3588S (VCCIO6 Domain)

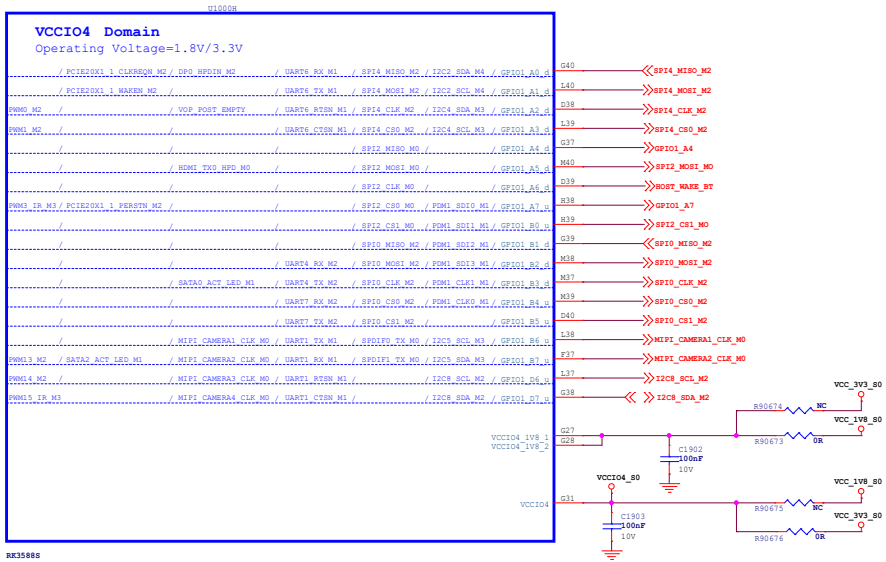

RK3588S (VCCIO5 Domain)

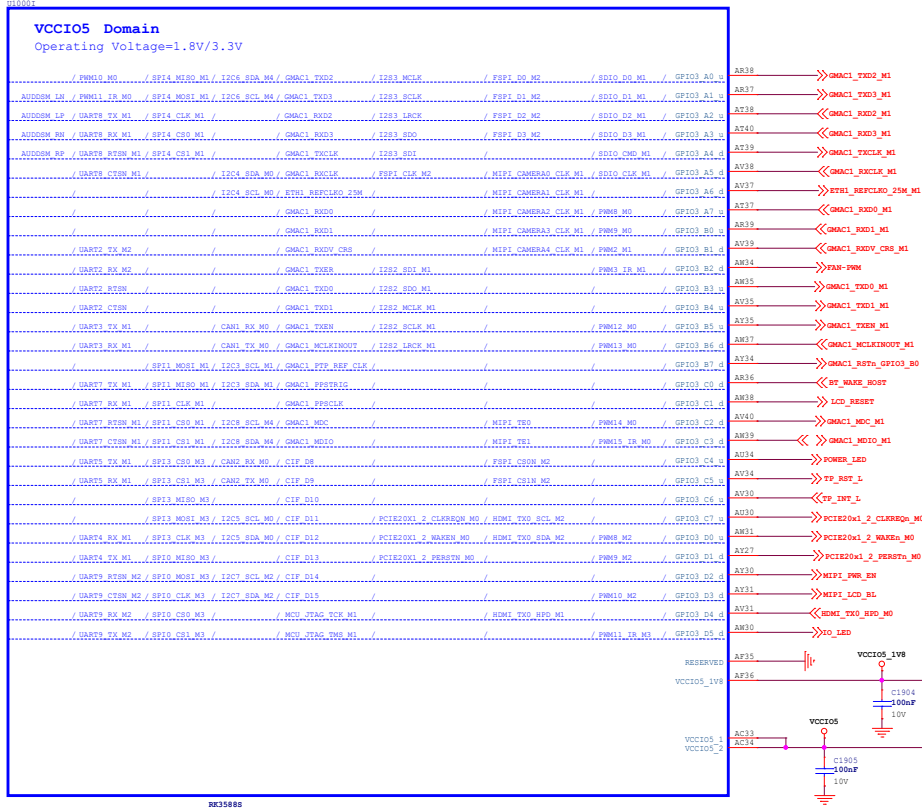

DRAM-LPDDR4/4x_2X32bit

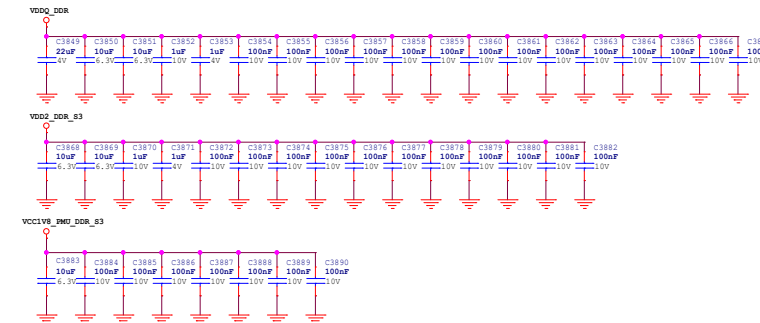
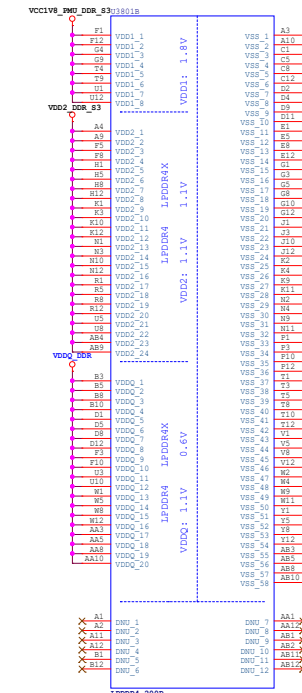
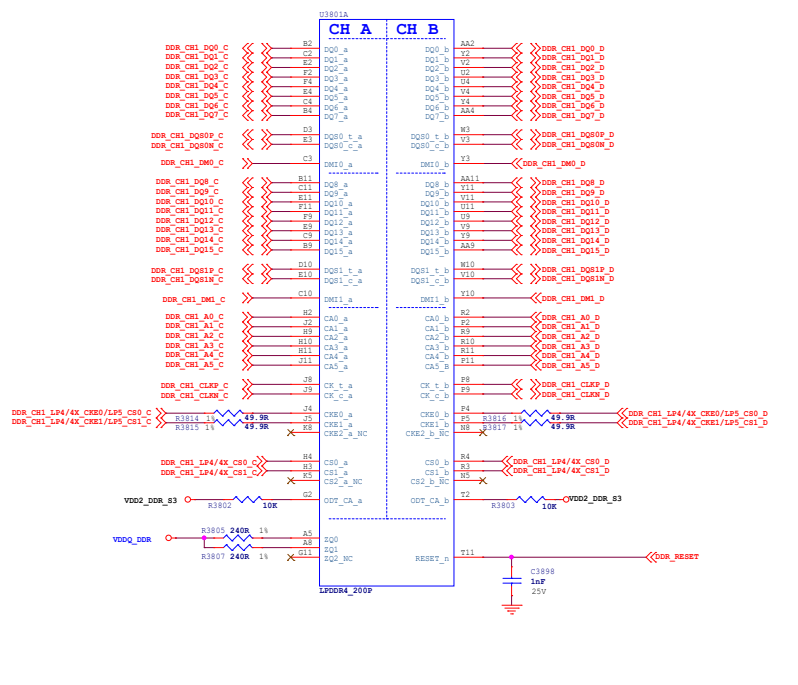
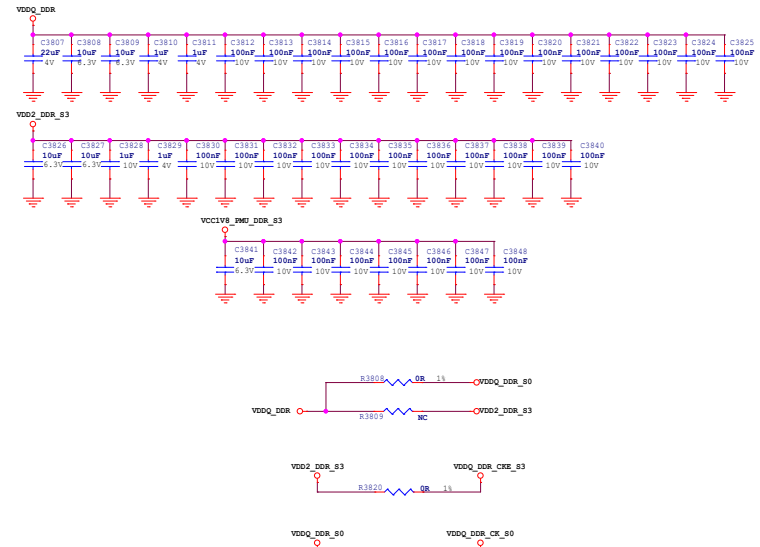
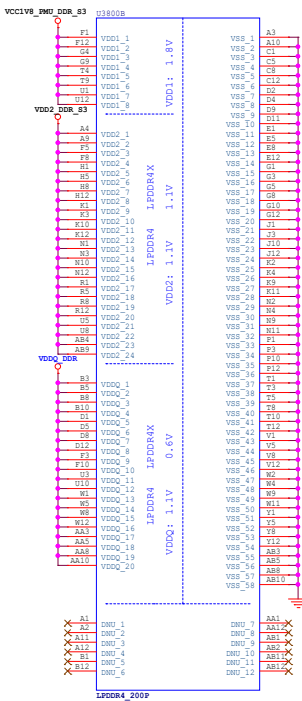
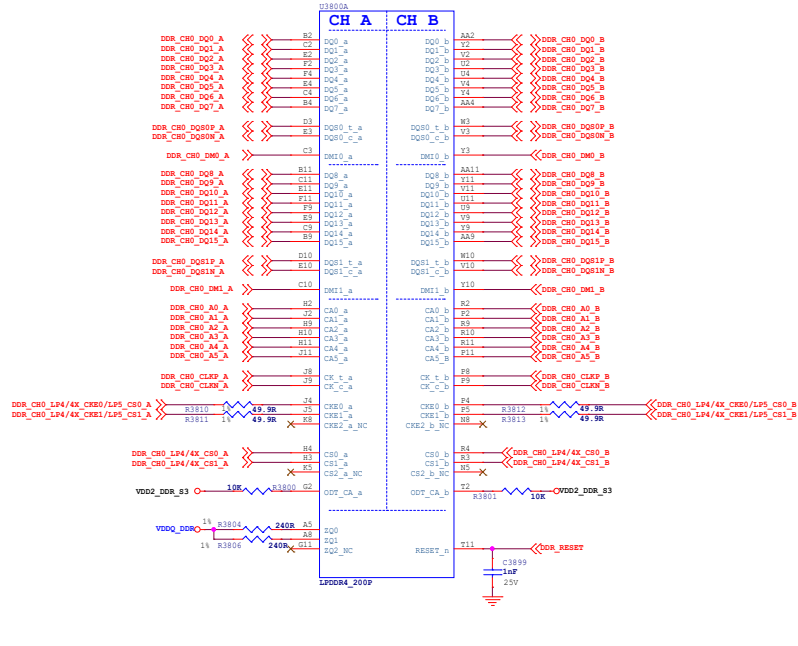

HDMI2.1 TX0

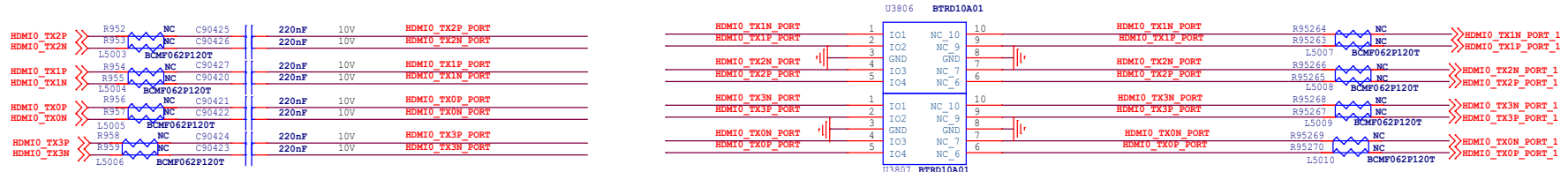

HDMI TX DDC

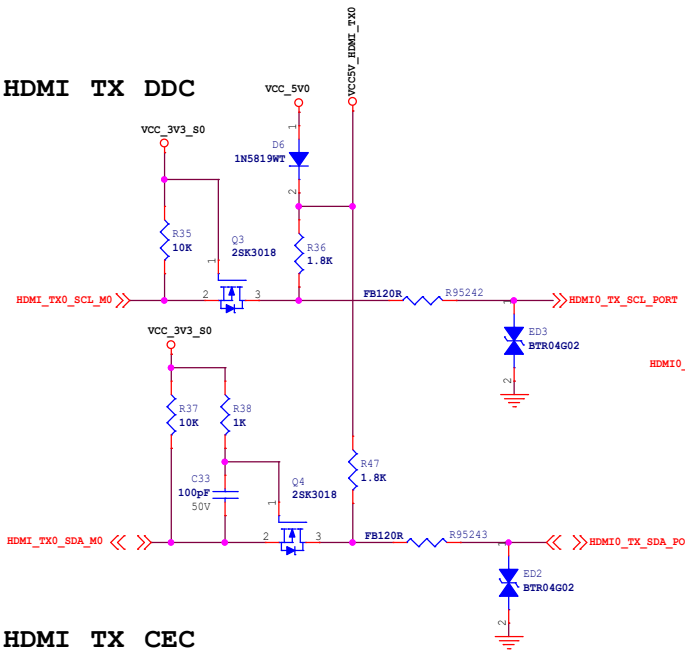

HDMI TX CEC

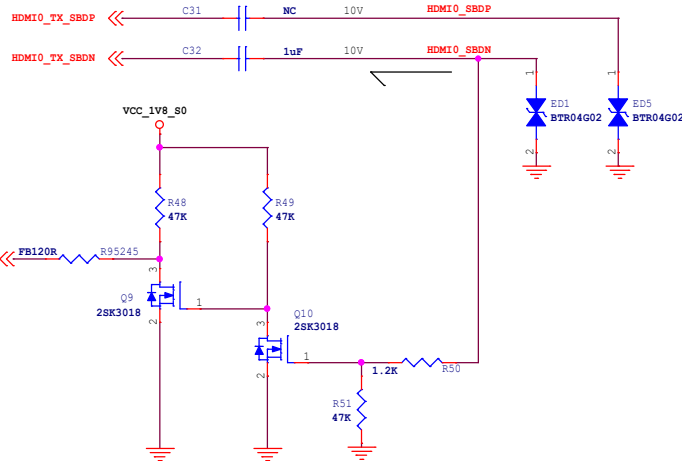
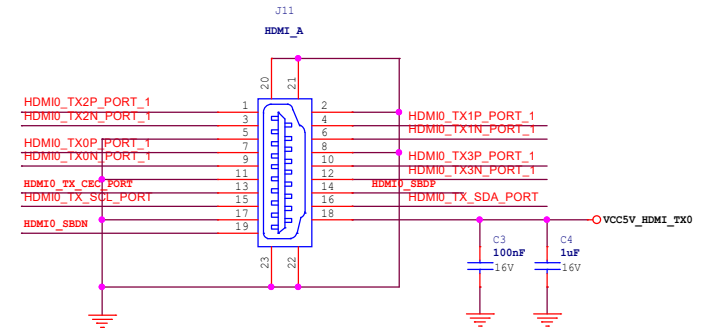
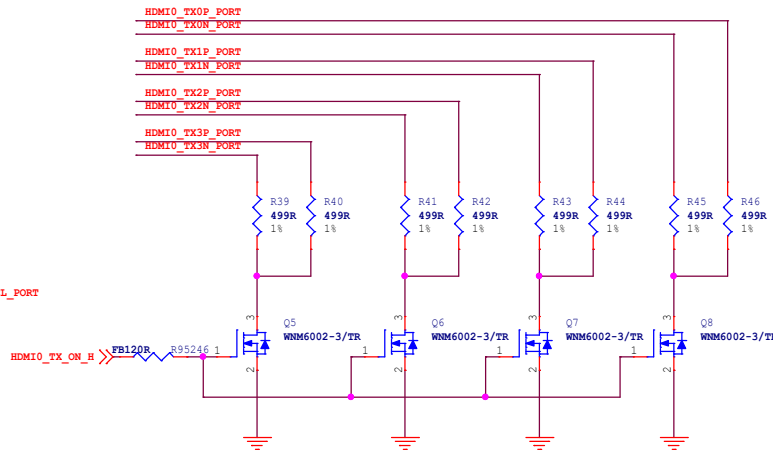
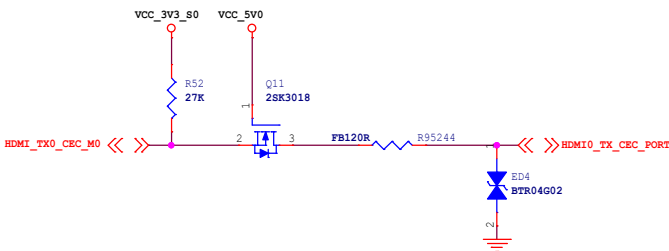

Size	Title:	ROCK 5C	REV
A3	Page Name:	MICRO HDMI 8K	1.1
Date:	Tuesday, March 26, 2024	Sheet	13 of 25

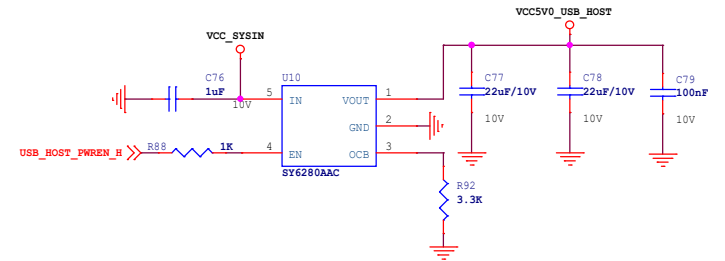
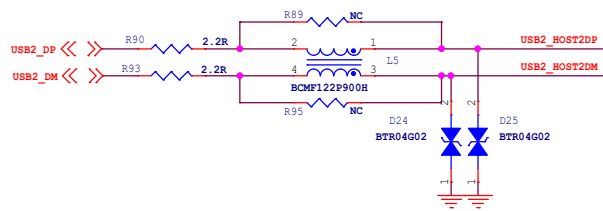
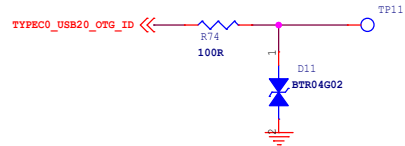
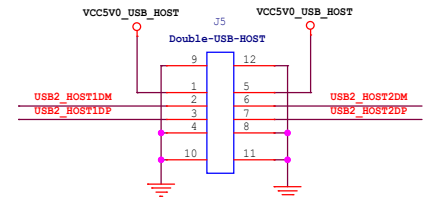
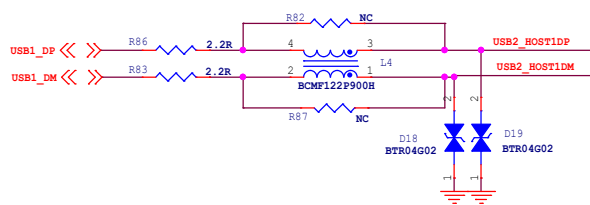
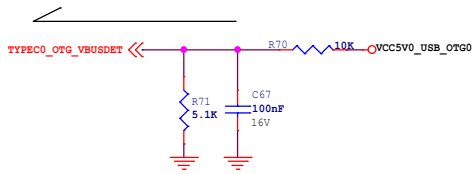
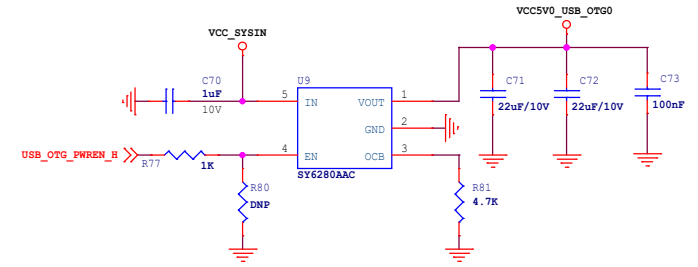
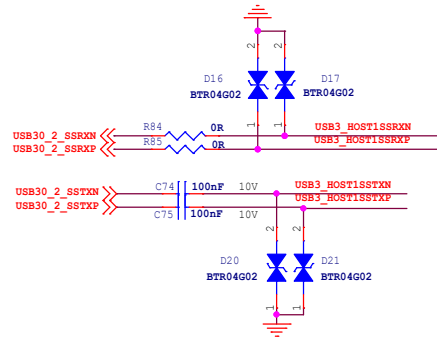
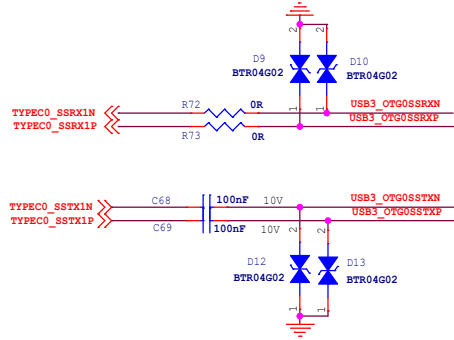
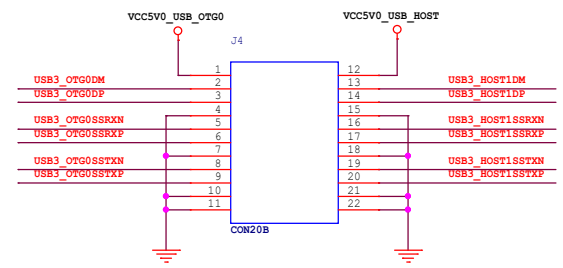
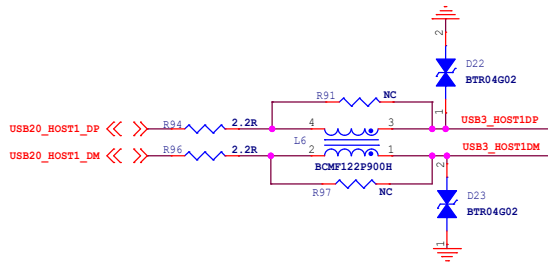
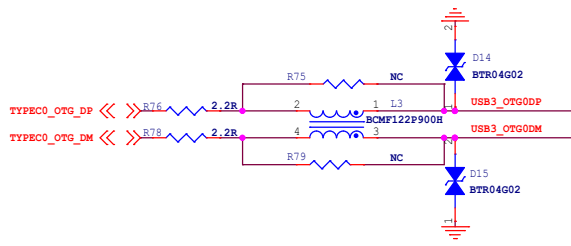

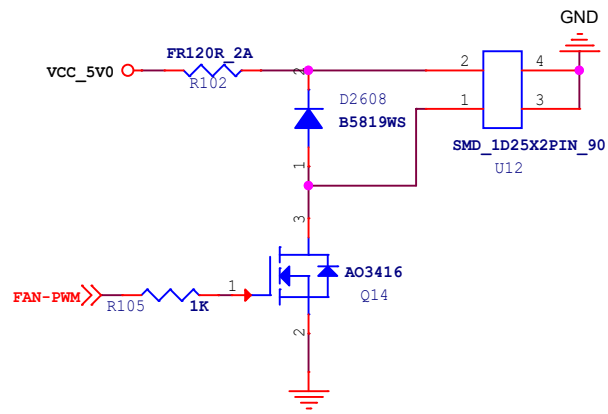
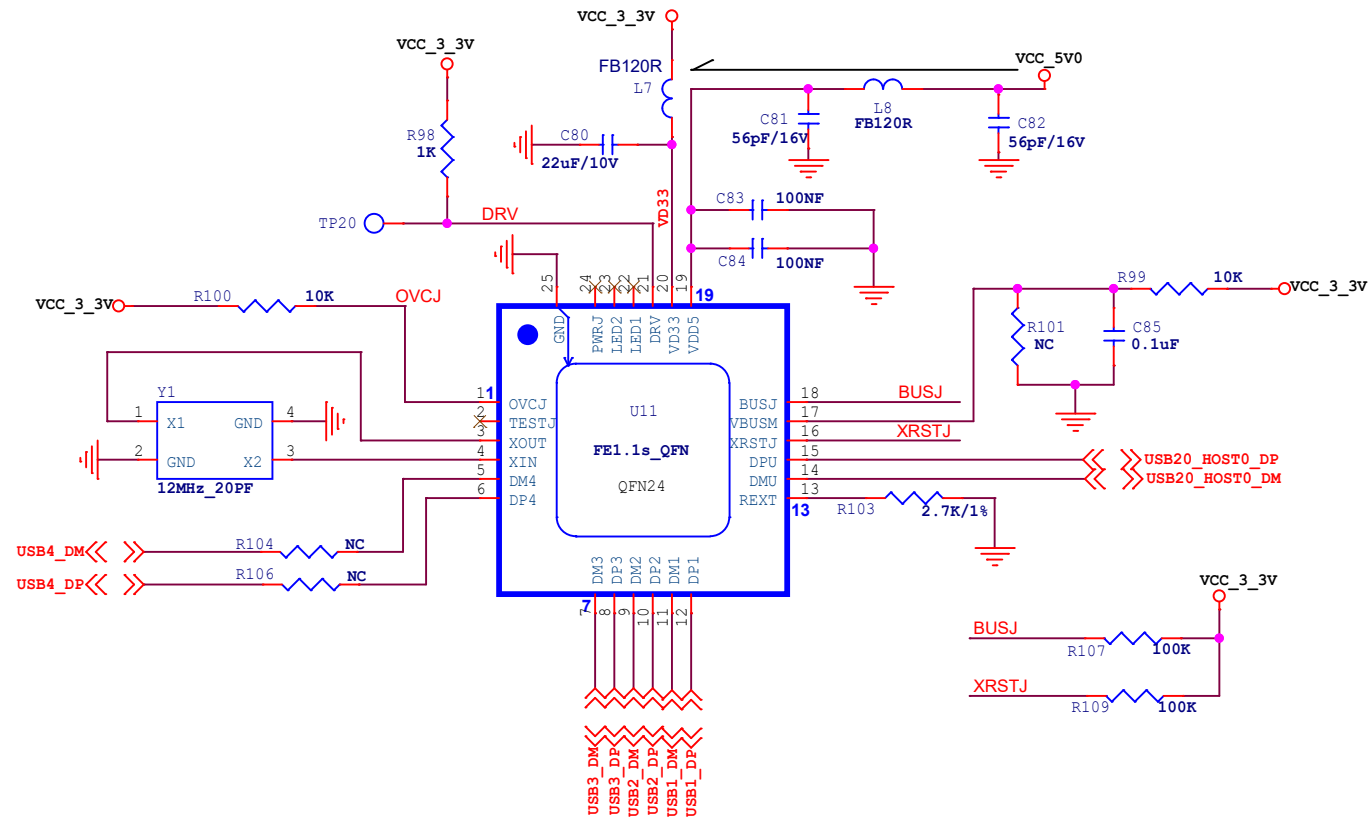

Giga PHY1

- >>> GMAC1_TXD0_M1
- >>> GMAC1_TXD1_M1
- >>> GMAC1_TXD2_M1
- >>> GMAC1_TXD3_M1
- >>> GMAC1_TXEN_M1
- >>> GMAC1_TXCLK_M1
- >>> GMAC1_RXD0_M1
- >>> GMAC1_RXD1_M1
- >>> GMAC1_RXD2_M1
- >>> GMAC1_RXD3_M1
- >>> GMAC1_RXDV_CRS_M1
- >>> GMAC1_RXCLK_M1
- >>> ETH1_REFCLKO_25M_M1
- >>> GMAC1_MCLKINOUT_M1
- >>> GMAC1_MDC_M1
- >>> GMAC1_MDIO_M1
- >>> GMAC1_RSTn_GPIO3_B0

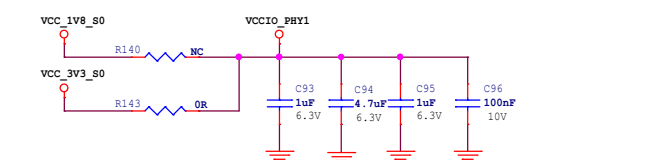
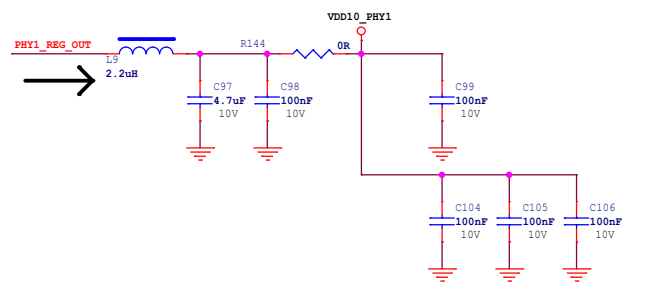
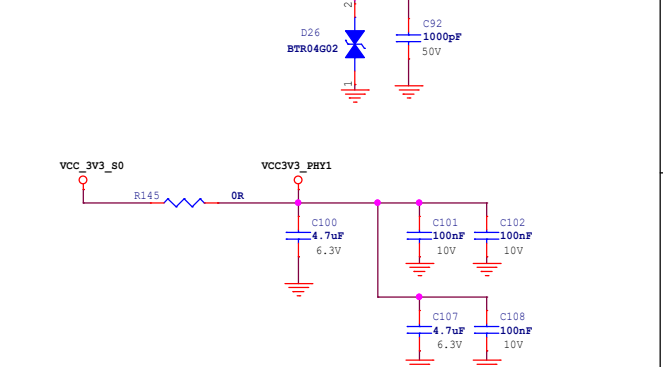
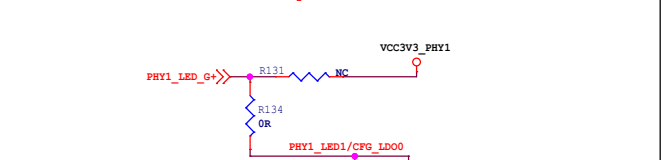
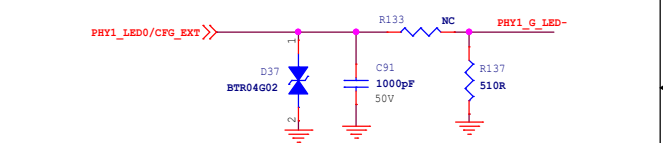
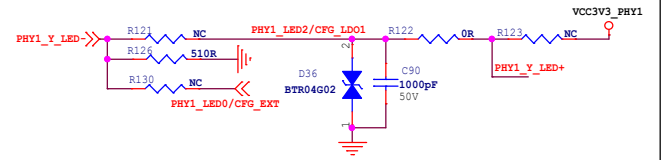
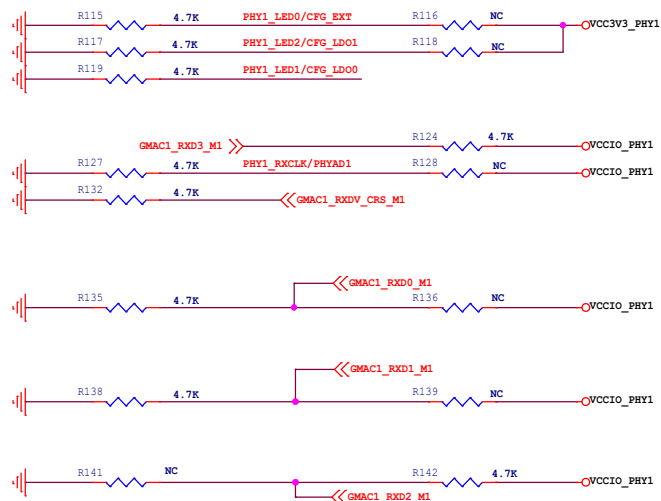
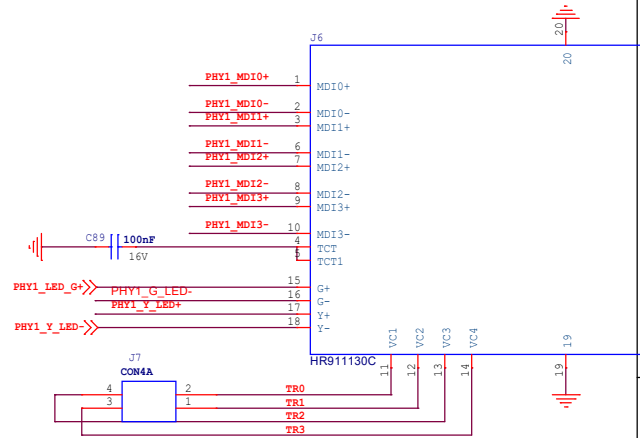
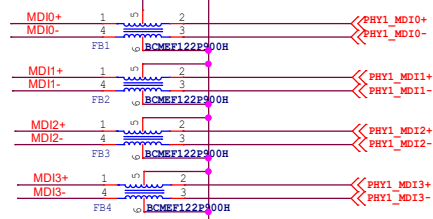
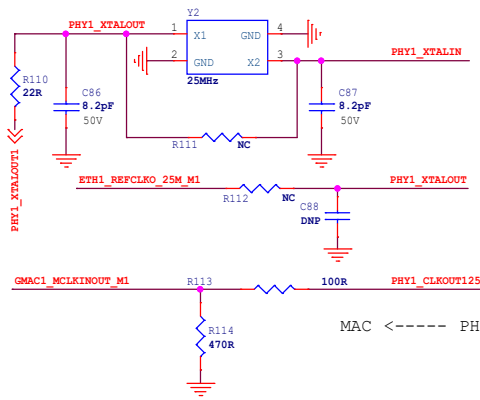

Size	Title:	ROCK 5C	REV
A3	Page Name:	Ethernet	1.1
Date:	Tuesday, March 26, 2024	Sheet	16 of 25

MIPI_LCD_TX1

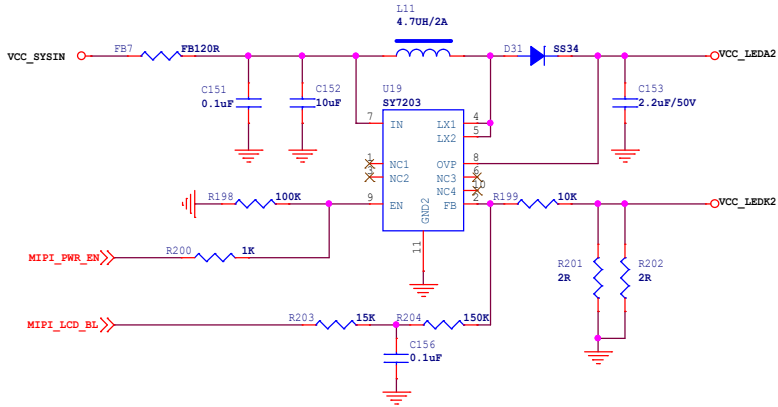

LCD_TP

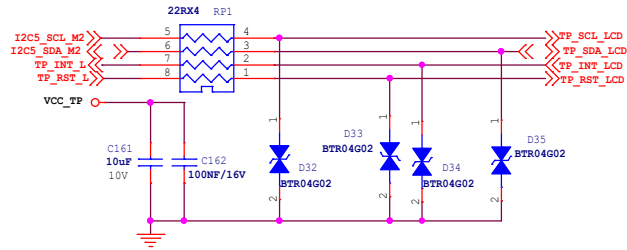

MIPI_RX

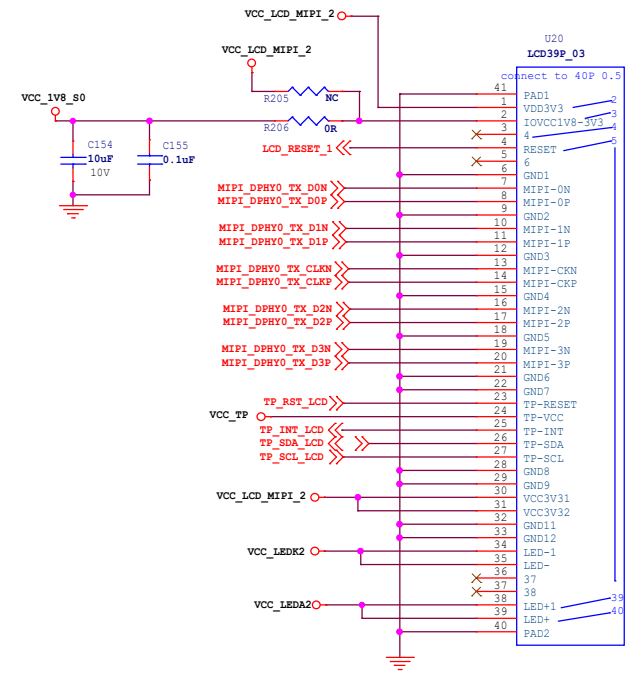
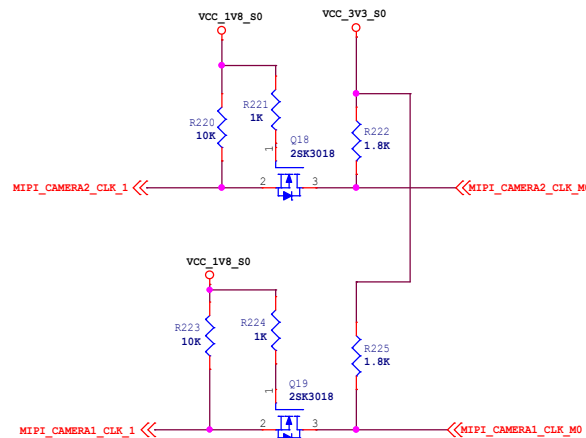
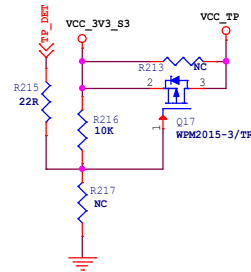
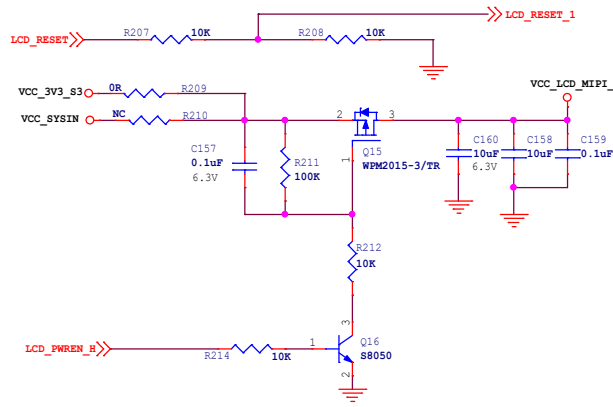
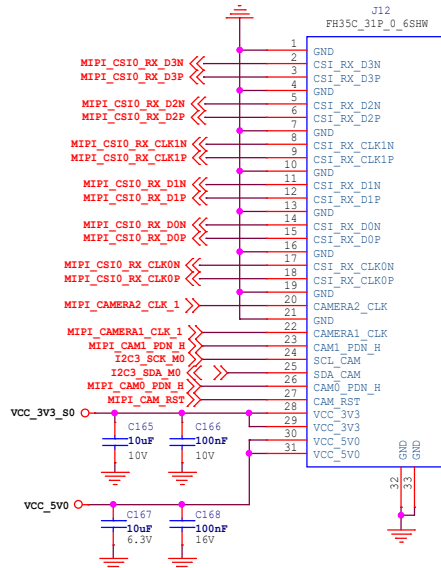

MicroSD Card

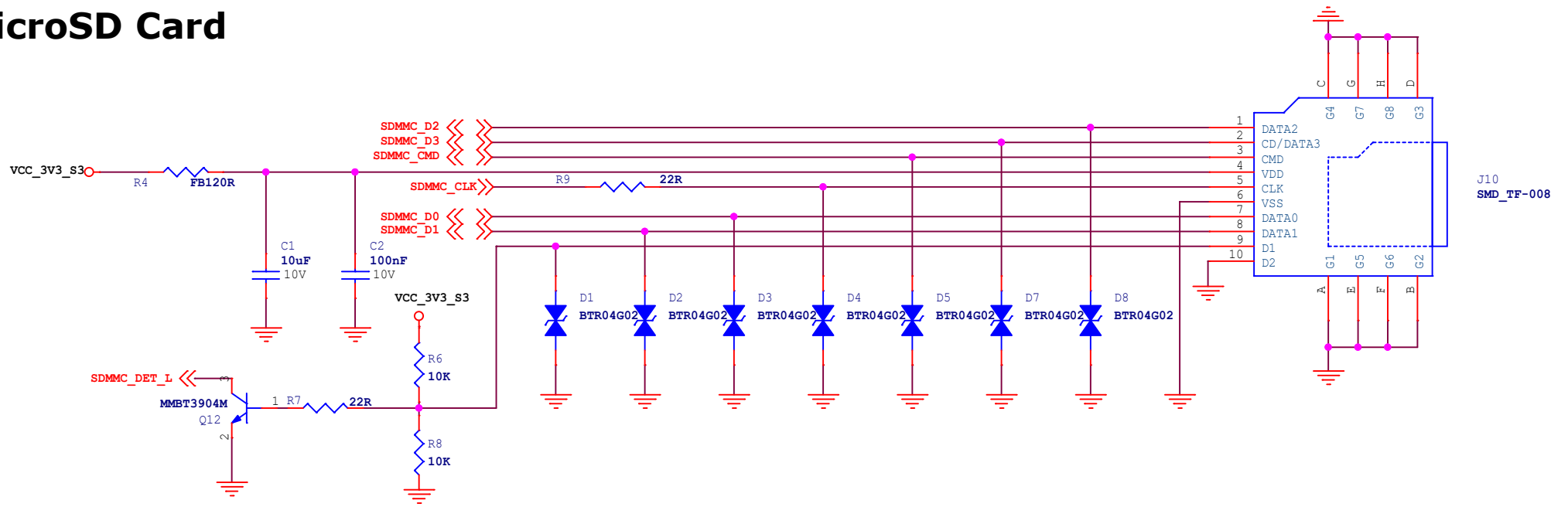

RTC IC

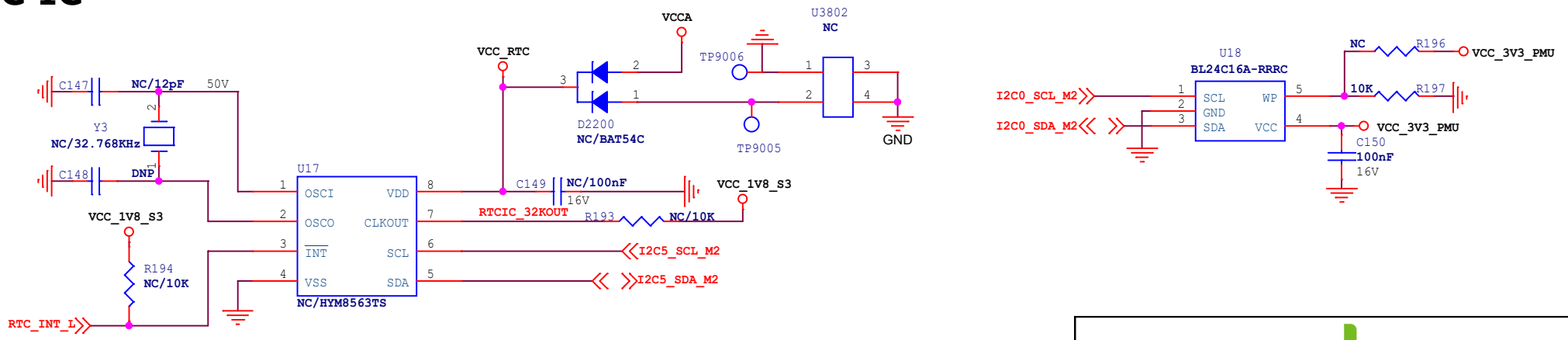

radxa		
Size	Title:	ROCK 5C
A4	Page Name:	SD Card/RTC
Date: Tuesday, March 26, 2024		Sheet 18 of 25
		REV 1.1

CODEC ES8316

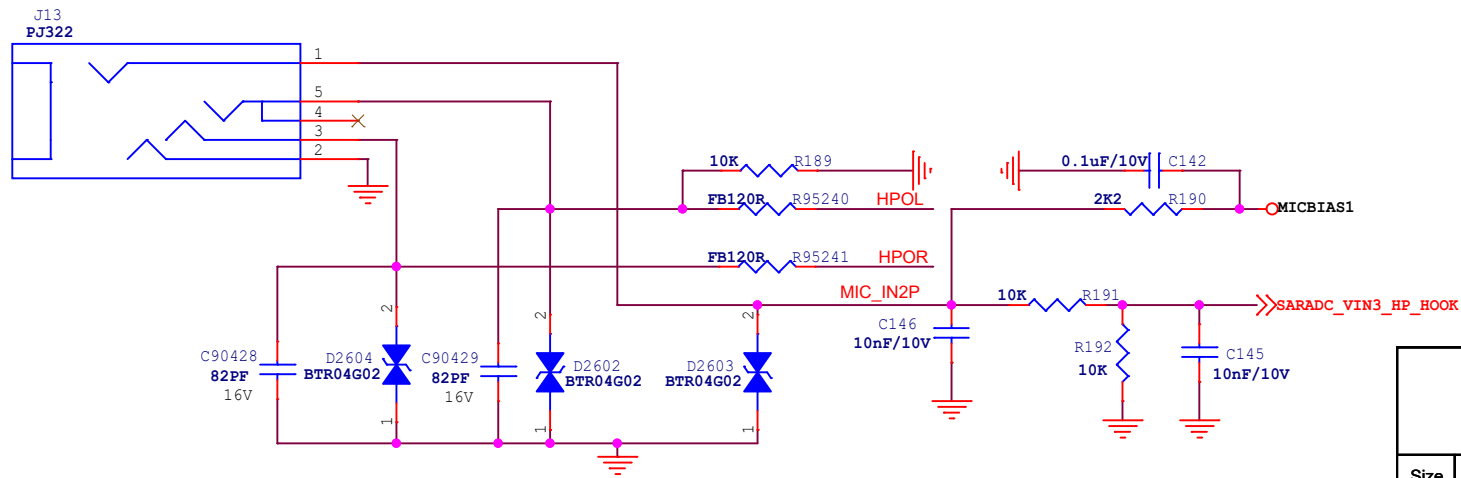
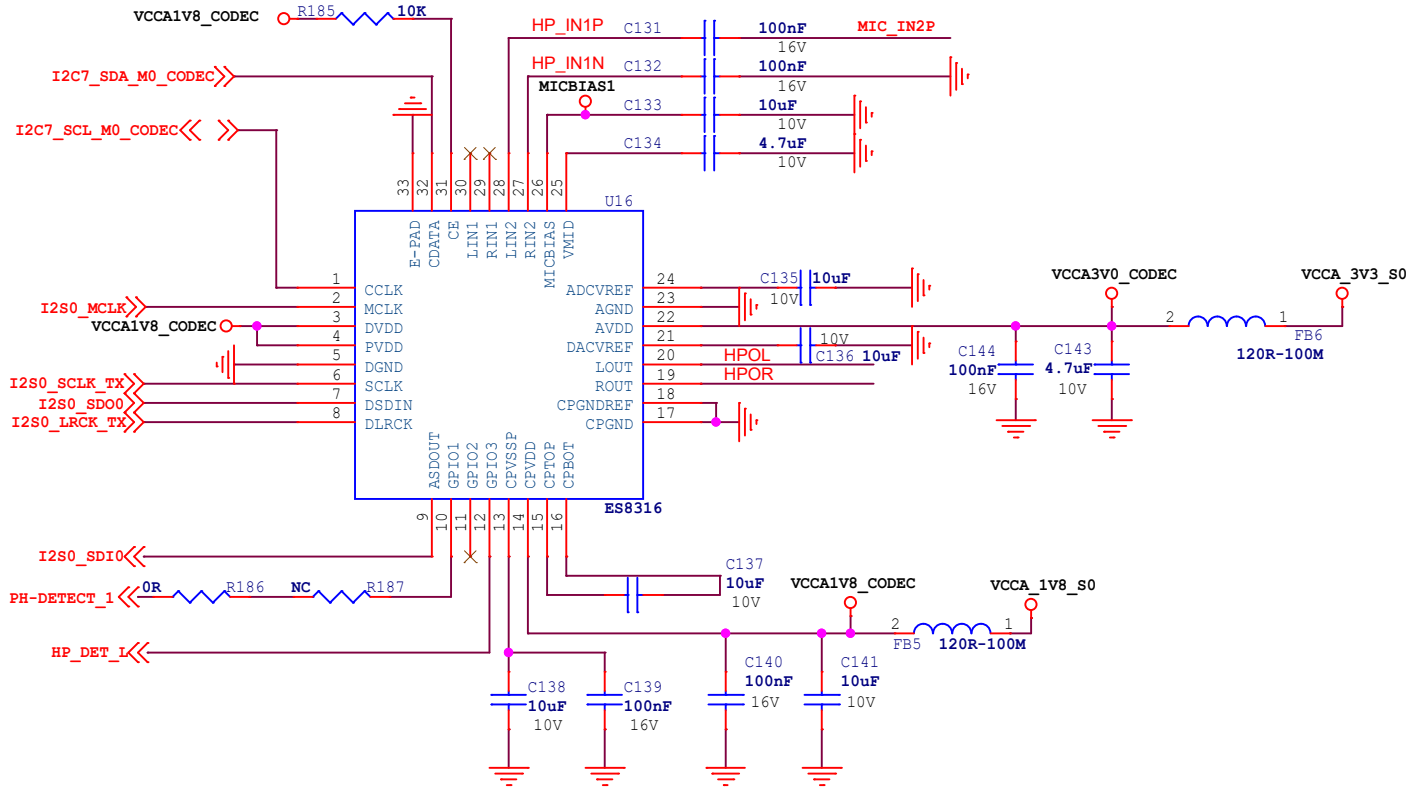

Size	Title:	ROCK 5C	REV
A4	Page Name:	Audio ES8316	1.1
Date:	Tuesday, March 26, 2024	Sheet	19 of 25

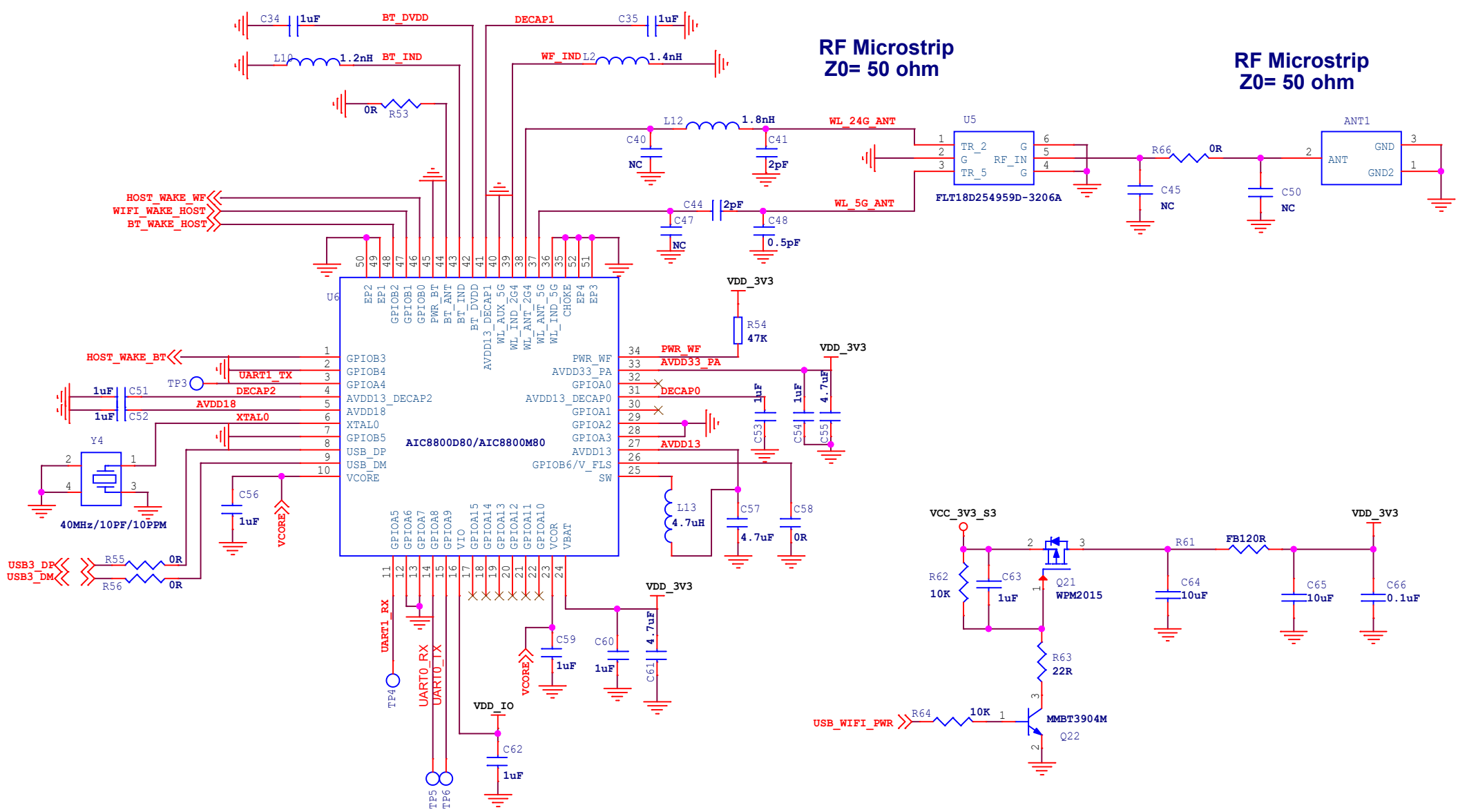

Size	Title:	ROCK 5C	REV
A4	Page Name:	USB_WIFI	1.1
Date:	Tuesday, March 26, 2024	Sheet	20 of 25

PCIE

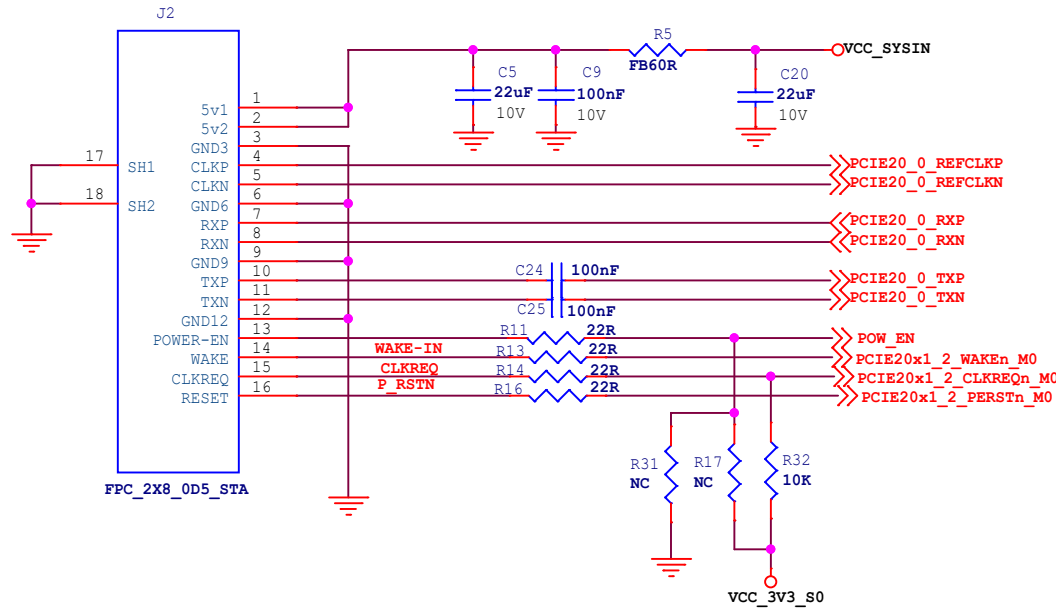

eMMC Flash

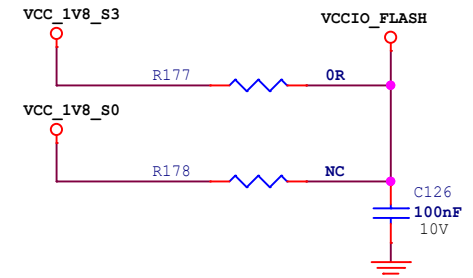
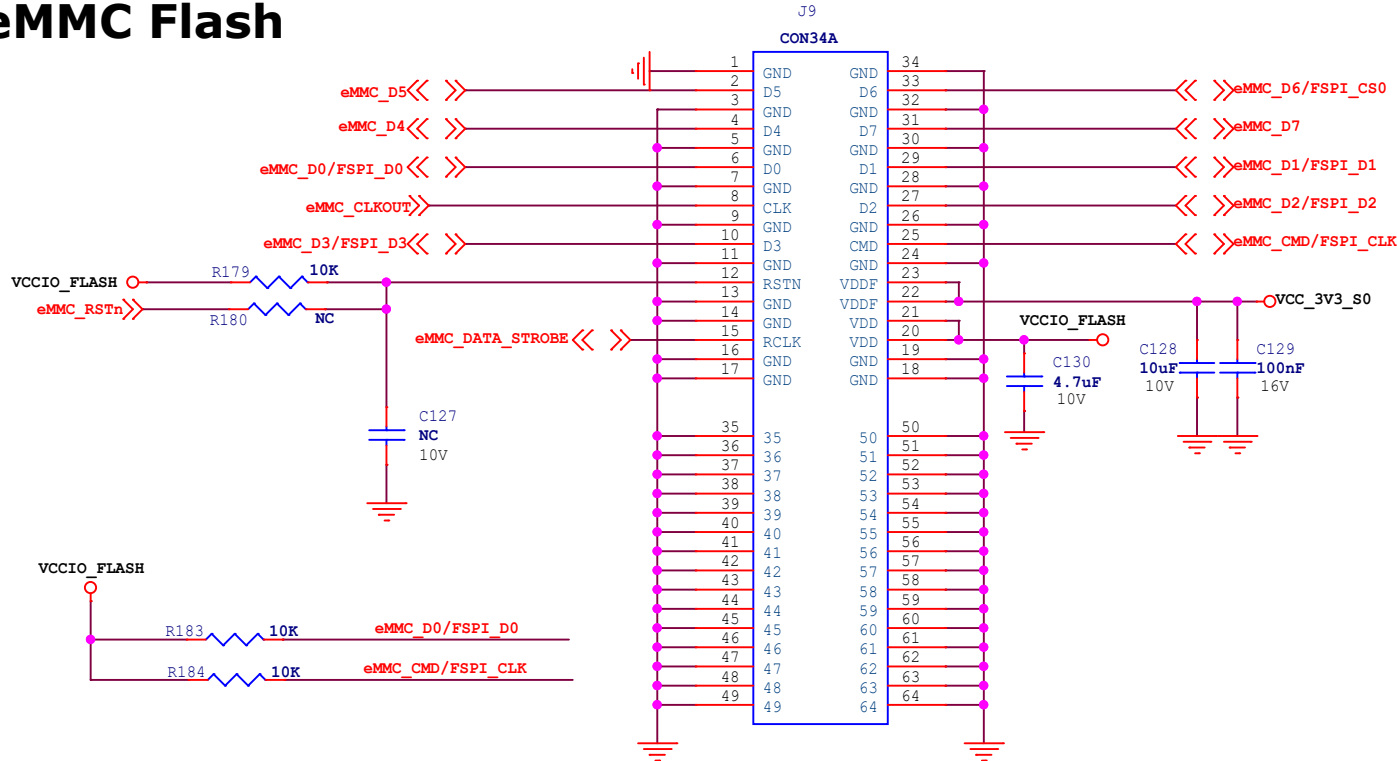

Size	Title:	ROCK 5C	REV
A4	Page Name:	EMMC FLASH/PCIE	1.1
Date:	Tuesday, March 26, 2024	Sheet	21 of 25

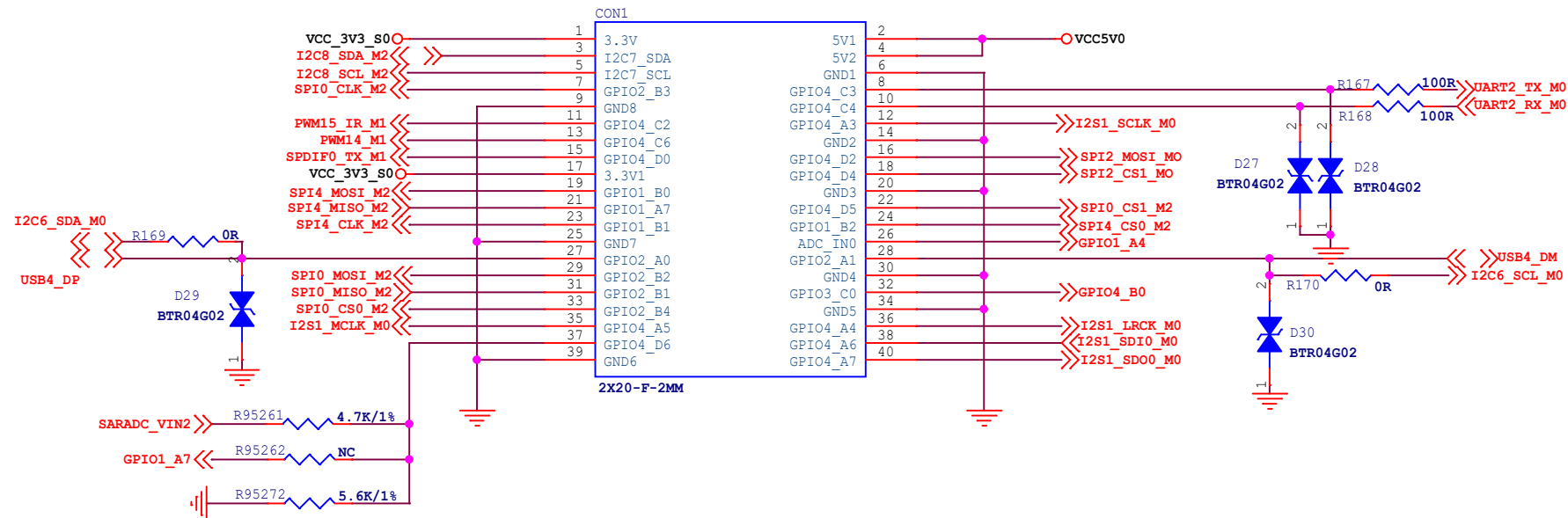

RECOVERY Key

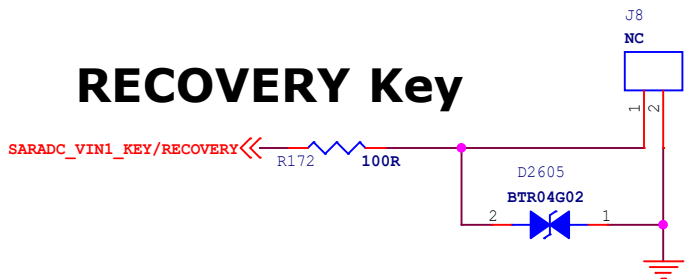

Maskrom Key

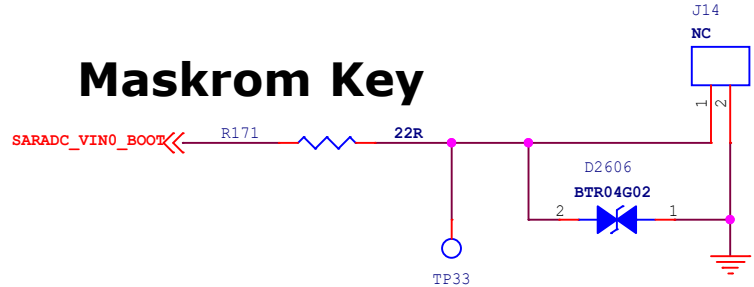

PowerOn/OFF_Key

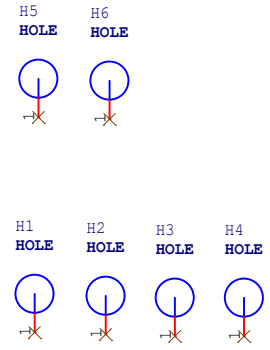
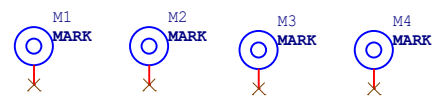
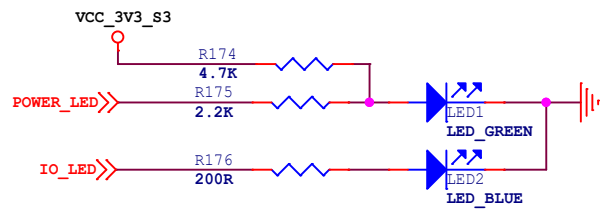
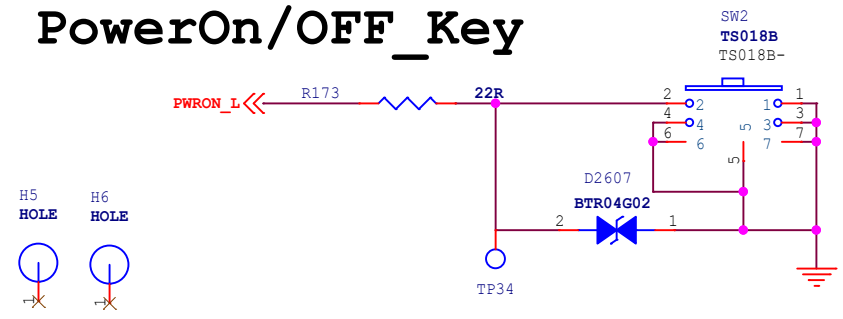



Size	Title: ROCK 5C	REV
A4	Page Name: 40PIN_CONNECT/KEY	1.1
Date: Tuesday, March 26, 2024 Sheet 22 of 25		

VDD_CPU_BIG0

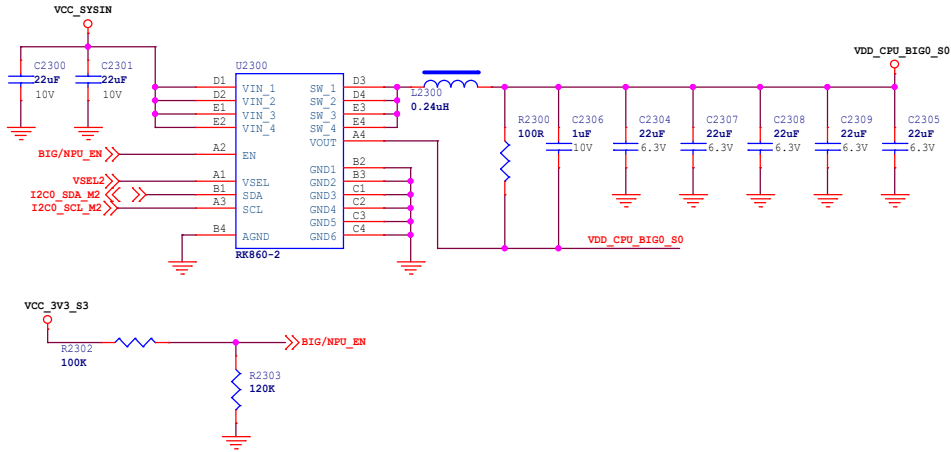

VDD_CPU_BIG1

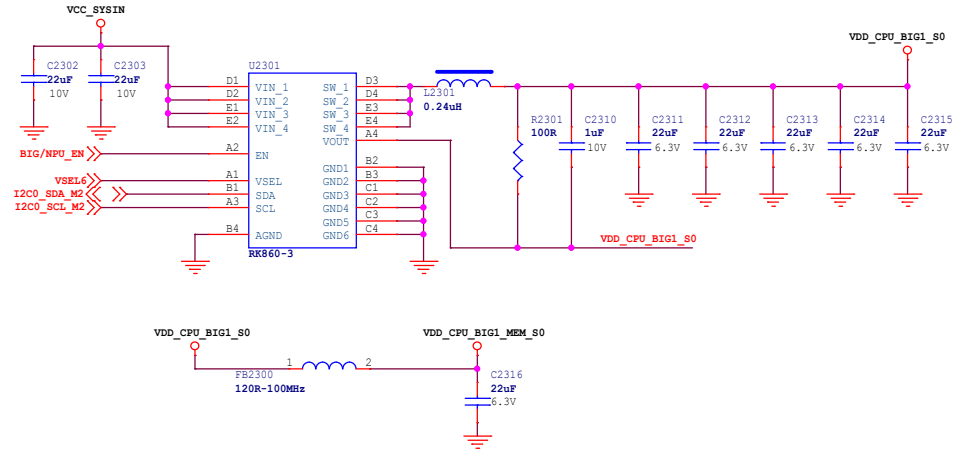

VDD_NPU

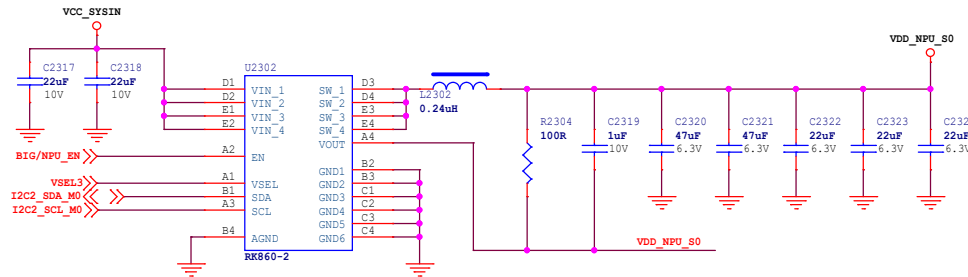

VCC_1V1_NLDO

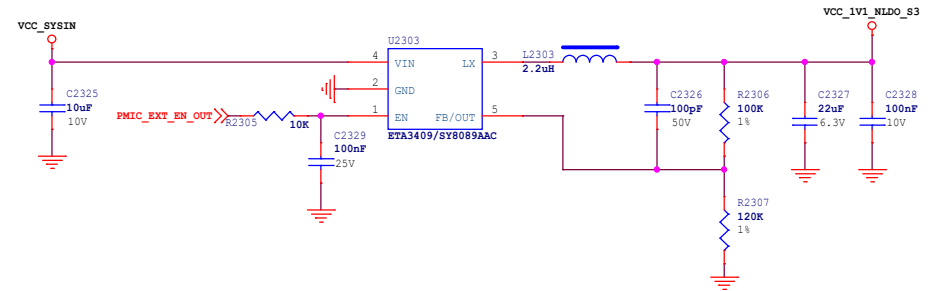

VCC_3V3_S0

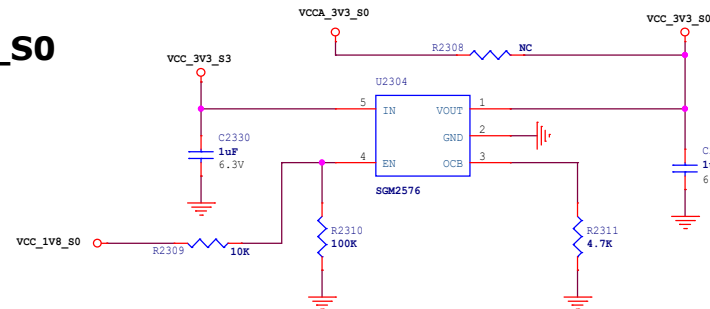

radxa

Size	Title:	ROCK 5C	REV
A3	Page Name:	Power Ext	1.1
Date:	Tuesday, March 26, 2024	Sheet	23 of 25

PMIC RK806-1 BUCK

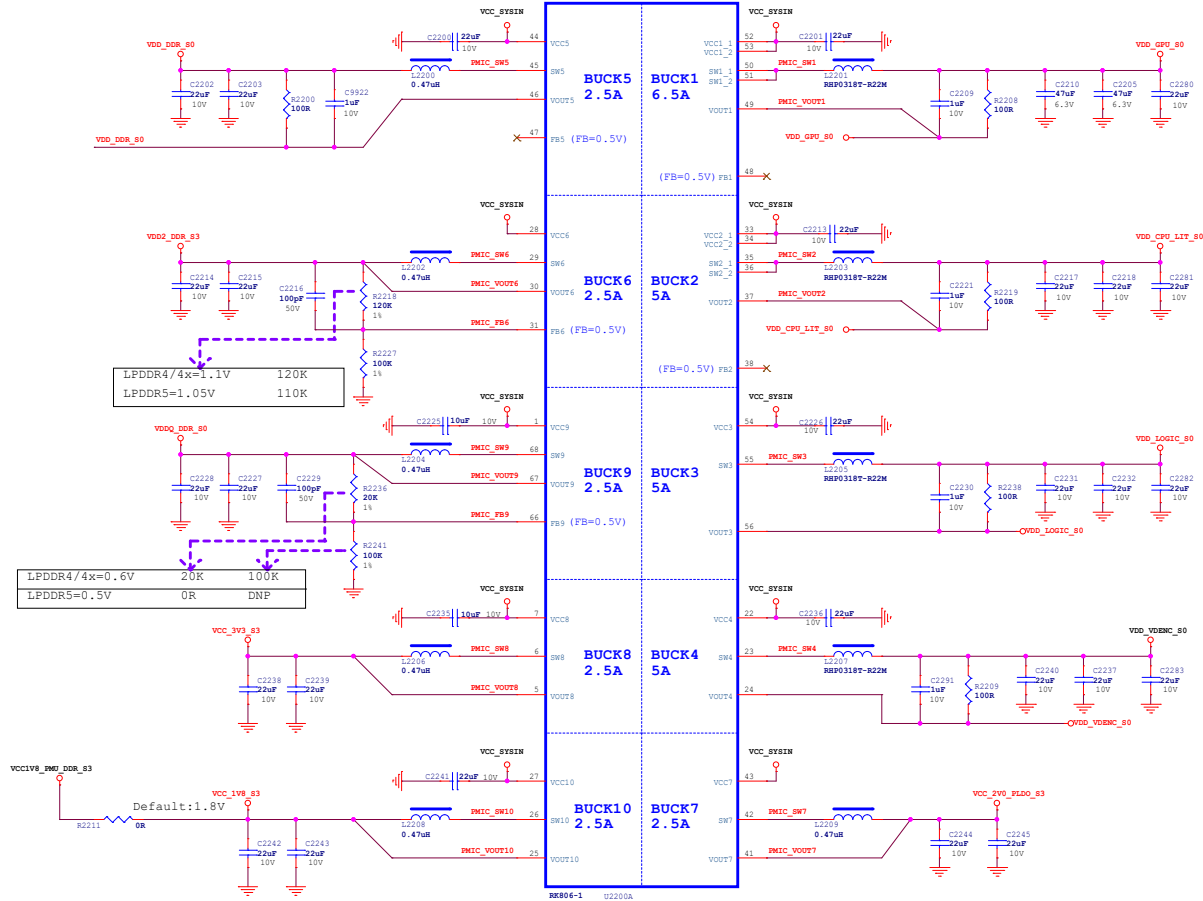

PMIC RK806-1 LDO

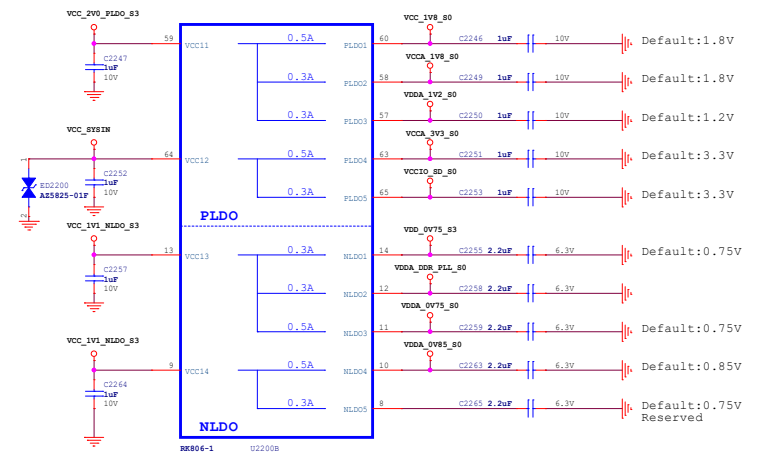

PMIC RK806-1 Management

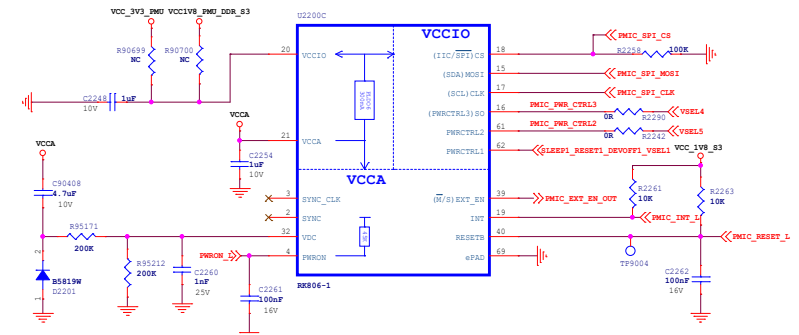

DC IN

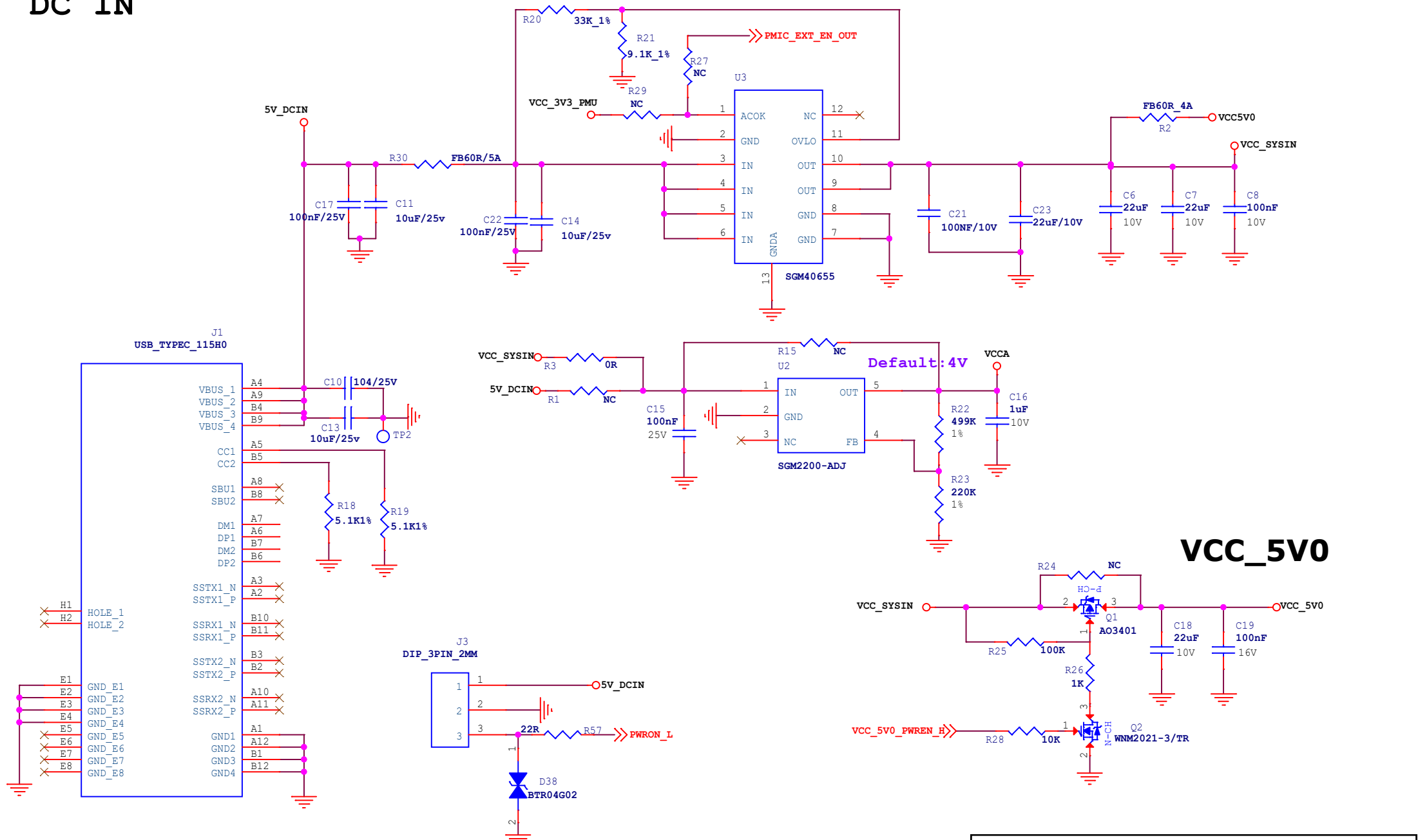

VCC_5V0



Size	Title:	ROCK 5C	REV
A4	Page Name:	Power DC IN	1.1
Date: Tuesday, March 26, 2024		Sheet	25 of 25