Radxa ROCK (Pi) 4A

Single Board Computer

Revision 1.0

2023-03-20



Contents

- 1 Revision Control Table 2
- 2 Introduction 3
- 3 Features 4
 - 3.1 Hardware 4
 - 3.2 Interfaces 4
 - 3.3 Software 5
- 4 Mechanical Specification 5
- 5 Electrical Specification 6
 - 5.1 Power Requirements 6
 - 5.2 GPIO Voltage 6
- 6 Operating Conditions 6
- 7 Peripherals 7
 - 7.1 GPIO Interface 7
 - 7.1.1 GPIO Alternate Functions 7
 - 7.2 eMMC Socket 8
 - 7.3 Camera and Display Interfaces 8
 - 7.4 USB 8
 - 7.5 HDMI 9
 - 7.6 Audio Jack 9
 - 7.7 M.2 Connector 9
- 8 Availability 9
- 9 Support 9

1 Revision Control Table

Version	Date	Changes from previous version
1.0	3/20/2023	First version with new template

2 Introduction

Radxa ROCK 4 Model A(ROCK 4A) is a Single Board Computer (SBC) in an ultra-small form factor that offers class-leading performance while leveraging outstanding mechanical compatibility. The Radxa ROCK 4A offers makers, IoT enthusiasts, hobbyists, PC DIY enthusiasts and others a reliable and extremely capable platform for building and tinkering their ideas into reality.

Radxa ROCK 4A offers 2GB or 4GB LPDDR4 ram options.

Radxa ROCK 4A

Name change notice:

When first introduced in 2018, the original product name was Radxa ROCK Pi 4A. In 2022, the ROCK Pi 4A was changed to ROCK 4A to avoid customer confusion with the Pi. However, in some documentation and third party reference, the product name is still ROCK Pi 4A. Both ROCK 4A and ROCK Pi 4A refer to the same product and share the same software. Please pay attention when downloading images or ask for support.

3 Features

3.1 Hardware

- Rockchip RK3399 SoC
- Arm® big.LITTLE™ technology (Dual Cortex-A72, frequency 1.8Ghz with quad Cortex-A53, frequency 1.4Ghz)
- Arm Mali™ T860MP4 GPU, supporting
 - OpenGL® ES 1.1 /2.0 /3.0 /3.1 /3.2
 - Vulkan® 1.0
 - Open CL® 1.1 1.2
 - DirectX® 11.1
- 2GB/4GB 64bits LPDDR4
- Dual display via HDMI/MIPI DSI
- H.265/VP9 (HEVC) hardware decode (up to 4Kp60)
- H.264 hardware decode (up to 1080p60)
- Support dual display, mirror or extend mode

3.2 Interfaces

- 1x 3.5mm Audio Jack with mic in
- 1x SD Card
- 1x HDMI port supporting displays up to 4Kp60 resolution
- 2x USB2 HOST ports
- 1x USB3 HOST port, 1x USB3 OTG port
- 1x Gigabit Ethernet port
- 1x camera port (2-lane MIPI CSI)
- 1x display port (2-lane MIPI DSI)
- 1x M.2 M Key (4-lane PCIe 2.1)
- 40x user GPIO supporting various interface options:
 - 1 x UART
 - 2 x SPI bus
 - 2 x I2C bus
 - 1 x PCM/I2S
 - 1 x SPDIF
 - 1 x PWM
 - 1 x ADC
 - 6 x GPIO
 - 2 x 5V DC power in
 - 2 x 3.3V power pin

3.3 Software

- Full implementation of the Arm architecture v8-A instructions set, Arm NEON Advanced SIMD (single instructions, multiple data) support for accelerating media and signal processing
- Armv8 cryptography extensions
- TrustZone® technology support
- Debian/Ubuntu Linux support
- Android 7.1/Android 9.0/Android 10/Android 11 support
- GPU enabled AI stack, (eg. Caffe)
- Hardware access/control library for Linux/Android

Software images can be downloaded from: <https://wiki.radxa.com/Rock4/downloads>

4 Mechanical Specification

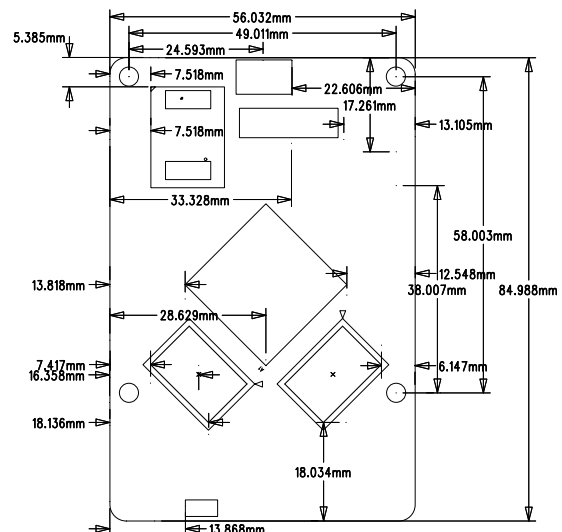
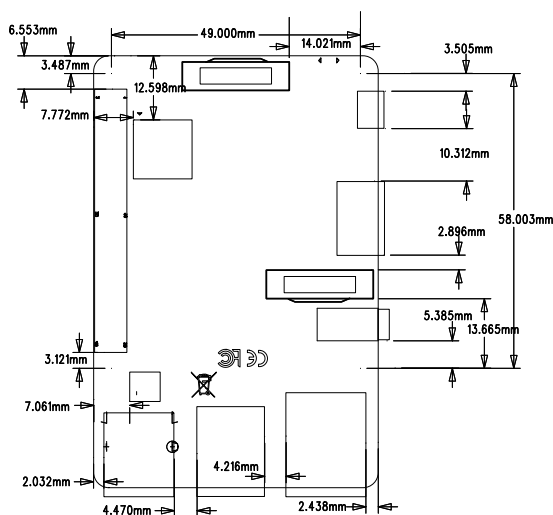

5 Electrical Specification

5.1 Power Requirements

The Radxa ROCK 4A supports various way of powering, smart power adapter as well as fixed voltage:

- USB PD 2.0 Support USB Type C PD 2.0, 9V/2A, 12V/2A, 15V/2A, 20V/2A
- Qualcomm® Quick Charge™ 2.0 Support QC3.0/2.0 adapter, 9V/2A, 12V/1.5A
- Power adapter with fixed voltage from 6V to 24V on the USB C power port
- 5V Power from the GPIO PIN 2 & 4

5.2 GPIO Voltage

GPIO	Voltage Level	Tolerance
GPIO3_C0	3.3V	3.465V
ADC_IN0	1.8V	1.98V
Other GPIO	3.0V	3.14V

6 Operating Conditions

The Radxa ROCK 4A has been designed to operate between 0°C to 50°C.

This temperature range was defined based on typical usage where the efficient use of Arm big.LITTLE technology can automatically select which processor core to utilise for a given task, the result of which is minimal heat generation and responsive user experience.

The Radxa ROCK 4 is built on a high-performance mobile chipset which is designed to operate for extended durations on batteries with efficiency at its core. As with all electronic devices heat is a by-product of operation which increases with performance and workload; during basic use cases such as web browsing, editing text or listening to music the SoC will automatically select the smallest processors available or dedicated hardware accelerators to reduce heat generation thus reserving the higher performance processors and thermal window for demanding tasks as and when required.

The SoC (Rockchip RK3399) is specified to limit its maximum internal temperature to 80°C before throttling the clock speeds to maintain reliability within the allowed temperature range. If the Radxa ROCK 4 is intended to be used continuously in high performance applications, it may be necessary to use external cooling methods (for example, heat sink, fan, etc.) which will allow the SoC to continue running at maximum clock speed indefinitely below its prede- fined 80°C peak temperature limiter.

7 Peripherals

7.1 GPIO Interface

The Radxa ROCK 4A offers a 40P GPIO expansion header which provides extensive compatibility with a wide range of accessories developed for the SBC market.

7.1.1 GPIO Alternate Functions

Function2	Function1	GPIO	Pin#	Pin#	GPIO	Function1	Function2
	+3.3V		1	2		+5.0V	
	I2C7_SDA	GPIO2_A7	3	4		+5.0V	
	I2C7_SCL	GPIO2_B0	5	6		GND	
	SPI2_CLK	GPIO2_B3	7	8	GPIO4_C4	UART2_TXD	
	GND		9	10	GPIO4_C3	UART2_RXD	
	PWM0	GPIO4_C2	11	12	GPIO4_A3	I2S1_SCLK	
	PWM1	GPIO4_C6	13	14		GND	
	SPDIF_TX	GPIO4_C5	15	16	GPIO4_D2		
	+3.3V		17	18	GPIO4_D4		
UART4_TXD	SPI1_TXD	GPIO1_B0	19	20		GND	
UART4_RXD	SPI1_RXD	GPIO1_A7	21	22	GPIO4_D5		
	SPI1_CLK	GPIO1_B1	23	24	GPIO1_B2	SPI1_CS _n	
	GND		25	26		ADC_IN0	
	I2C2_SDA	GPIO2_A0	27	28	GPIO2_A1	I2C2_CLK	

Function2	Function1	GPIO	Pin#	Pin#	GPIO	Function1	Function2
I2C6_SCL	SPI2_TXD	GPIO2_B2	29	30		GND	
I2C6_SDA	SPI2_RXD	GPIO2_B1	31	32	GPIO3_C0	SPDIF_TX	UART3_CTSn
	SPI2_CS _n	GPIO2_B4	33	34		GND	
	I2S1_LRCK_TX	GPIO4_A5	35	36	GPIO4_A4	I2S1_LRCK_RX	
		GPIO4_D6	37	38	GPIO4_A6	I2S1_SDI	
	GND		39	40	GPIO4_A7	I2S1_SDO	

7.2 eMMC Socket

The Radxa ROCK 4A offers a high speed eMMC socket for eMMC modules which can be used for OS and data storage. The eMMC socket is compatible with readily available industrial pinout and form factor hardware.

7.3 Camera and Display Interfaces

The Radxa ROCK 4A has 1x 2-lane MIPI CSI Camera and 1x 2-lane MIPI DSI Display connector. These connectors are backwards compatible with standard industrial camera and display peripherals.

7.4 USB

The Radxa ROCK 4A is equipped with 4 USB ports.

There are two native speed USB 2 HOST ports powered from a shared regulator which also provides power to the lower USB 3 port. The cumulative power output across these three ports is 1.44A.

The board also has two USB 3 HOST ports which are driven directly from the RK3399 SoC which means they can also run at full native speed(5Gbps). The upper USB 3 port can be configured to OTG mode by moving the slide switch located on the underside of the board below the USB ports. Power to the upper USB 3 port is driven directly by a regulator which can provide up to 1.44A current.

7.5 HDMI

The Radxa ROCK 4A has 1x full-sized HDMI port, which supports CEC (Consumer Electronics Control, a feature of HDMI designed to control HDMI connected devices by using only one remote controller) and HDMI 2.0 with UHD resolution up to 4Kp60 (~ 3840 x 2160 px)

7.6 Audio Jack

The Radxa ROCK 4A supports high quality analogue audio output via a 4-ring 3.5mm headphone jack. The analog audio output can drive 32 Ohm headphones directly. The audio jack also supports microphone input as default.

7.7 M.2 Connector

The Radxa ROCK 4A offers offers a M.2 M Key connector with 4-lan PCIe 2.1 interface, providing high speed M.2 NVMe SSD expansions, M.2 SATA SSD is not supported.

8 Availability

Radxa guarantee availability of the Radxa ROCK 4A until at least September 2029.

9 Support

For support please see the hardware documentation section of the [Radxa Wiki](#) website and post questions to the [Radxa forum](#).