

CONTENT INDEXING

- 01.Index
- 02.Change List
- 03.Power Tree
- 04.I2C Map
- 05.Power Domain Map
- 06.RK3399 Power
- 07.RK3399 PMU Controler
- 08.RK3399 DDR Controler
- 09.RK3399 Flash&SDMMC Controler
- 10.RK3399 USB/USIC Controler
- 11.RK3399 SARADC/Key
- 12.RK3399 DVP Interface
- 13.RK3399 Display Interface
- 14.RK3399 GPIO
- 15.RK3399 PCIE
- 16.Power-DC IN
- 17.Power-PMIC RK808-D
- 18.RTL8211E
- 19.USB OTG/HOST Port
- 20.RAM-LPDDR3(178P)
- 21.Memory-eMMC
- 22.WIFI/BTMIMO-AP6354
- 23.TF Card
- 24.HDMI Output
- 25.PCie NGFF/M.2
- 26.ES8316
- 27.CONNECTOR

Note:

器件参数说明

1:如果 Value 为 DP 说明暂时不贴。

2:如果 Option 有 DP 说明先不贴。

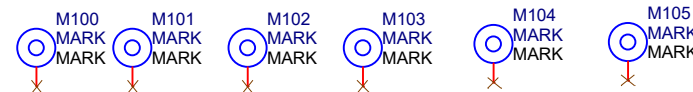
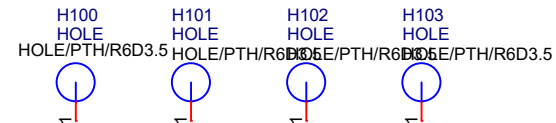

Size	ROCK PI 4	REV
A4	Page Name: Index	1.6
Date: Wednesday, June 16, 2021	Sheet 1 of 27	

Change List

Version	Date	Author	Change Note	Approved
V1.0	201708	Charlie	First edition	



RK3399 POWER DIAGRAM

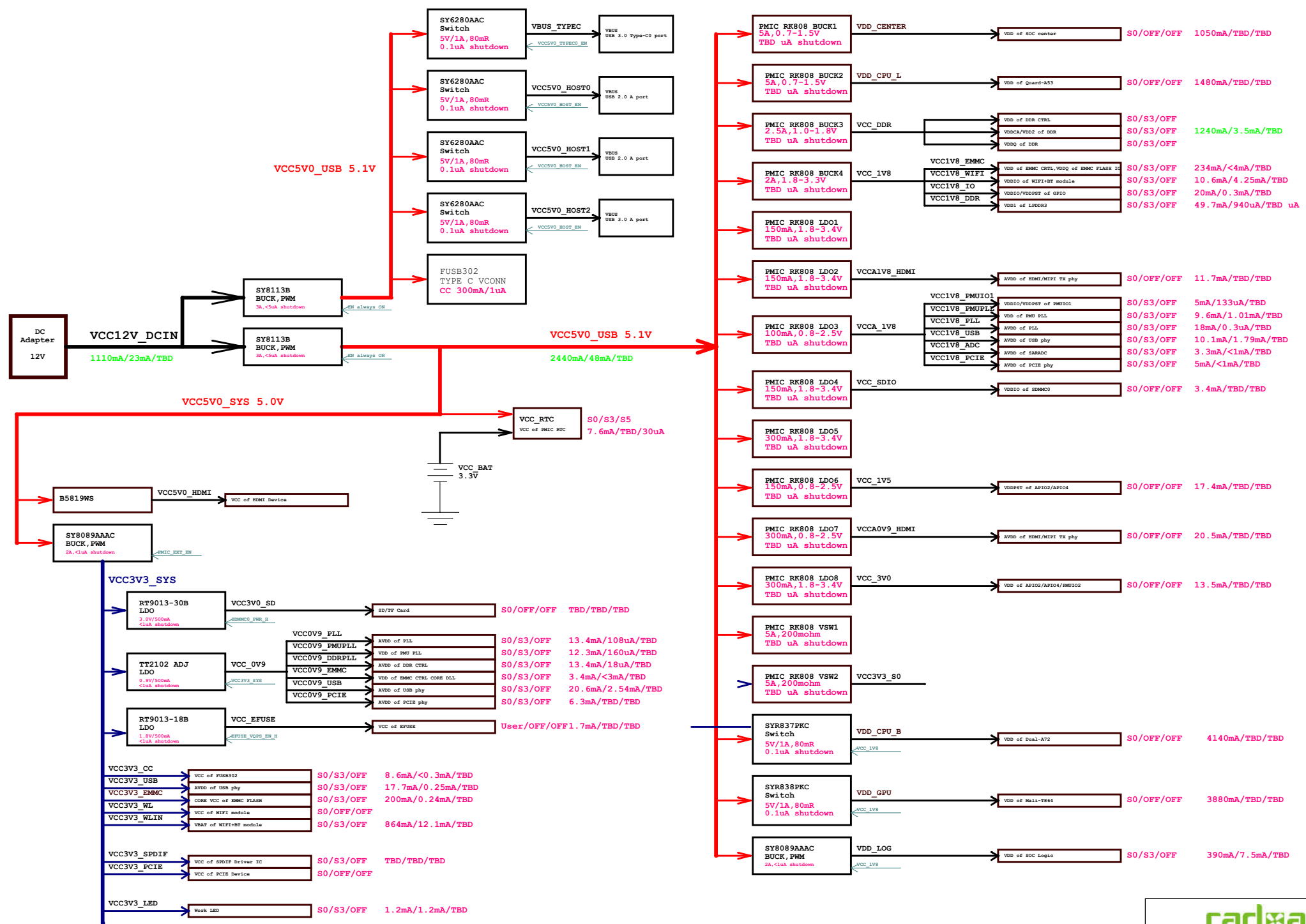

I2C MAP

Port	Pin name	Domain	Bus name	Pull-up voltage	Slave Device	Slave Addr (MS 7Bits)	Note	Slave Bus Capability
I2C0	GPIO1_B7/SPI3_RXD/I2C0_SDA GPIO1_C0/SPI3_TXD/I2C0_SCL	PMUIO2	I2C_SDA_PMIC I2C_SCL_PMIC	VCC_1V8	Rockchip RK808	0x1b	PMIC	100kHz, 400KHz
					SYR837PKC	0x40	DC-DC BUCK	100kHz, 400KHz, 3.4MHz
					SYR838PKC	0x41	DC-DC BUCK	100kHz, 400KHz, 3.4MHz
I2C1	GPIO4_A1/I2C1_SDA GPIO4_A2/I2C1_SCL	APIO5		VCC_1V8			Low Speed CONNECTOR	
I2C2	GPIO2_A0/VOP_D0/CIF_D0/I2C2_SDA GPIO2_A1/VOP_D1/CIF_D1/I2C2_SCL	APIO2		VCC_1V8			High Speed CONNECTOR	
I2C3	GPIO4_C0/I2C3_SDA/UART2B_RX GPIO4_C1/I2C3_SCL/UART2B_TX	APIO4	I2C_SDA_HDMI I2C_SCL_HDMI	VCC_3V0				
I2C4	GPIO1_B3/I2C4_SDA GPIO1_B4/I2C4_SCL	PMUIO2	I2C_SDA_MEMS I2C_SCL_MEMS	VCC_1V8	Fairchild FUSB302B	0x44, 0x46	USB-TypeC Mux	100kHz, 400KHz, 1MHz
I2C5	GPIO3_B2/MAC_RXER/I2C5_SDA GPIO3_B3/MAC_CLK/I2C5_SCL	APIO1	Other pin function					
I2C6	GPIO2_B1/SPI2_RXD/CIF_HREF/I2C6_SDA GPIO2_B2/SPI2_TXD/CIF_CLKIN/I2C6_SCL	APIO2		VCC_1V8			Low Speed CONNECTOR	
I2C7	GPIO2_A7/VOP_D7/CIF_D7/I2C7_SDA GPIO2_B0/VOP_CLK/CIF_VSYNC/I2C7_SCL	APIO2		VCC_1V8			High Speed CONNECTOR	



Size	ROCK PI 4	REV
A4	Page Name: I2C Map	1.6
Date:	Wednesday, June 16, 2021	Sheet 4 of 27

Power Domain Map

Part Port	Domain	Pin name in datasheet	I/O type	Power supply	Power source
Part C	PMUIO1	pmuiol_gpio0ab	1.8V only	VCCA_1V8	RK808-D VLDO3
Part E	PMUIO2	pmu1830_gpio1abcd	1.8V (Default) 3.0V	VCC_1V8	RK808-D Buck4
Part I	APIO1	gmac_gpio3abc	3.3V only	VCC_1V8 VCC3V3_SYS	RK808-D Buck4
Part L	APIO2	bt656_gpio2ab	1.8V (Default) 3.0V	VCC_1V8	RK808-D VLDO3
Part G	APIO3	wifi/bt_gpio2cd	1.8V only	VCC_1V8	RK808-D Buck4
Part K	APIO4	gpio1830_gpio4cd	1.8V 3.0V (Default)	VCC_1V5 VCC_3V0	RK808-D VLDO6 RK808-D VLDO8
Part J	APIO5	audio_gpio3d_gpio4a	1.8V (Default) 3.0V	VCC_1V8	RK808-D Buck4
Part F	SDMMC0	sdmmc_gpio4b	1.8V 3.0V (Default)	VCC_SDIO	RK808-D VLDO4



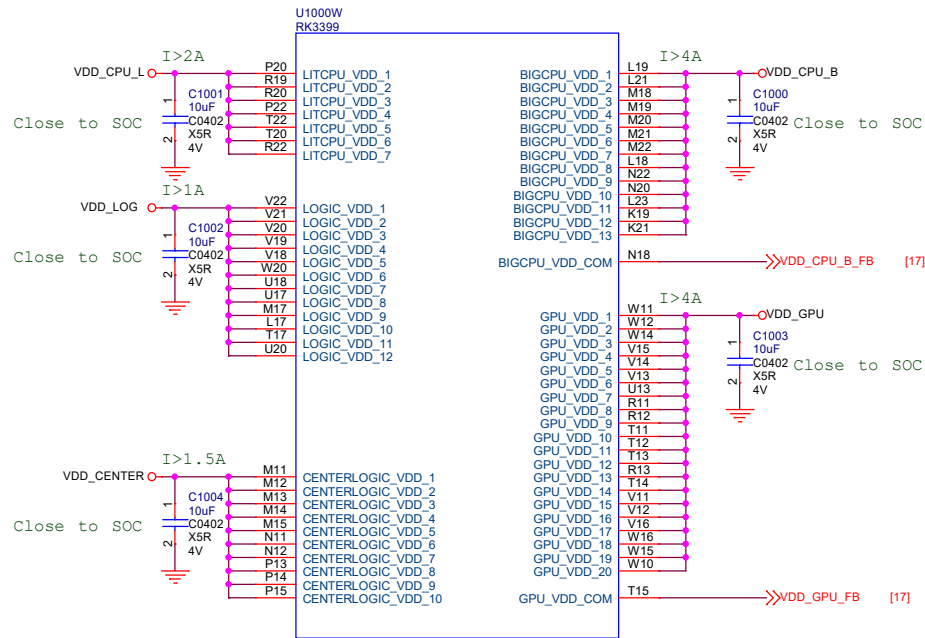

Note: Power filter CAP please place back of SOC or close to SOC

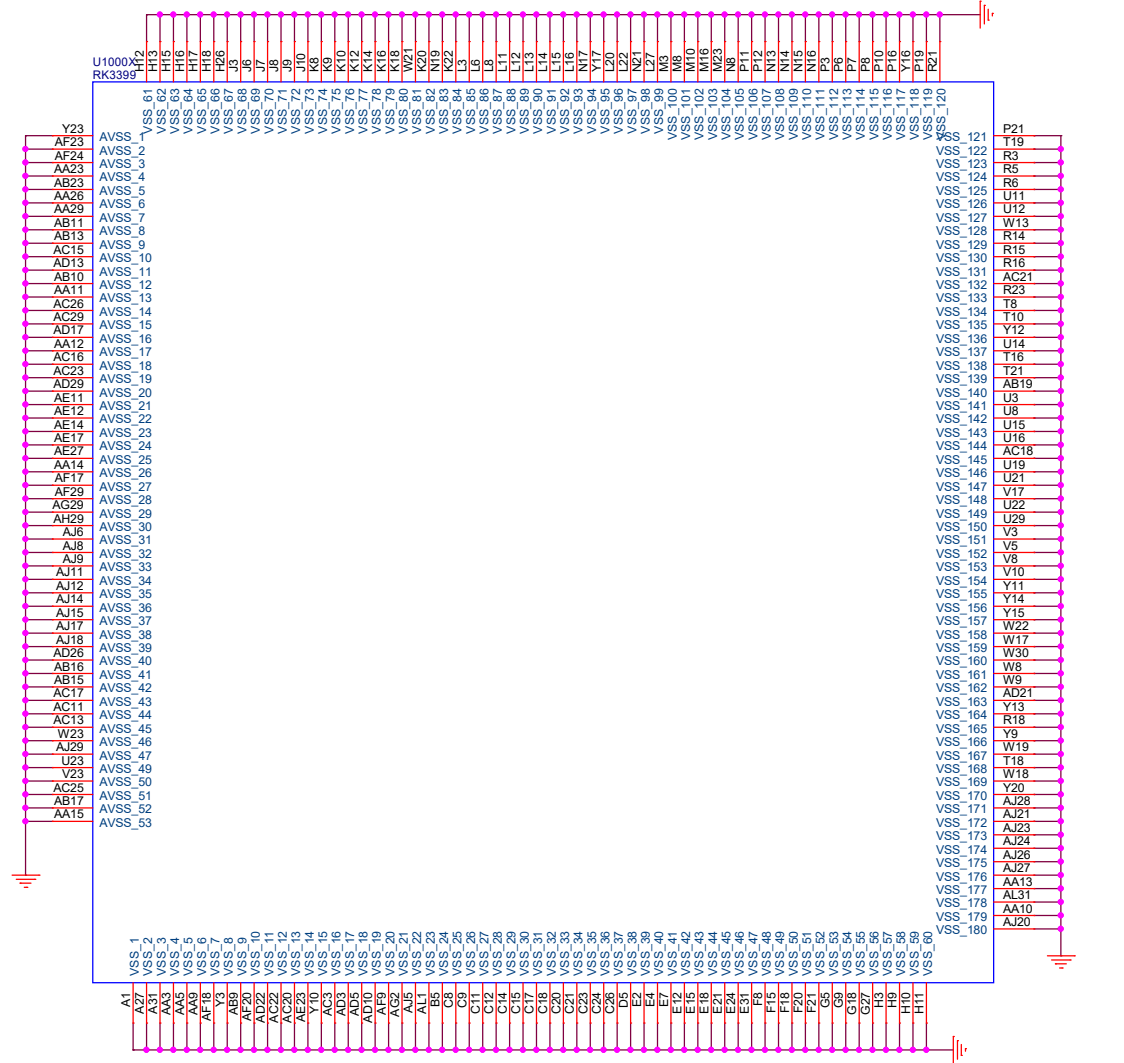
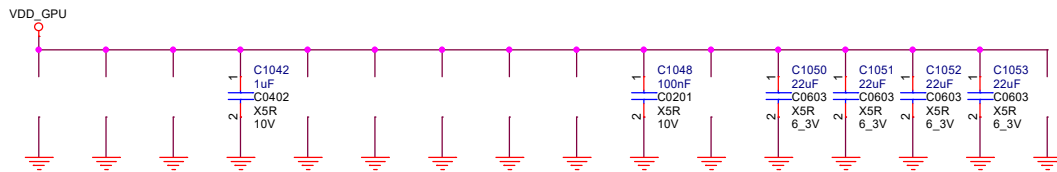
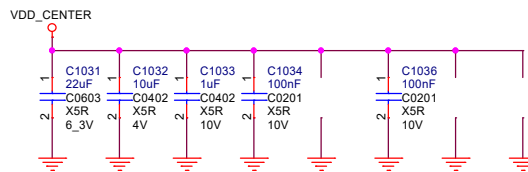
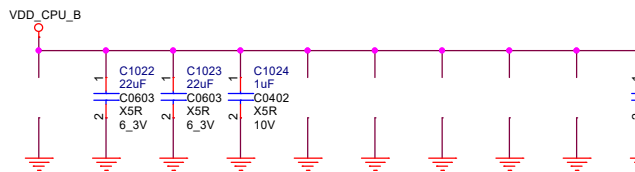
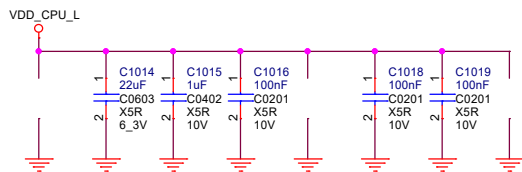
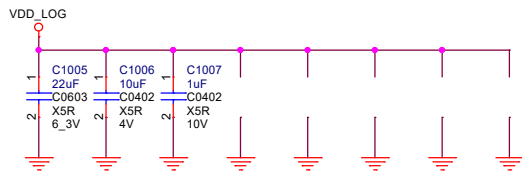



Size	ROCK PI 4	REV
A3	Page Name: RK3399 Power	1.6
Date: Wednesday, June 16, 2021	Sheet 6 of 27	

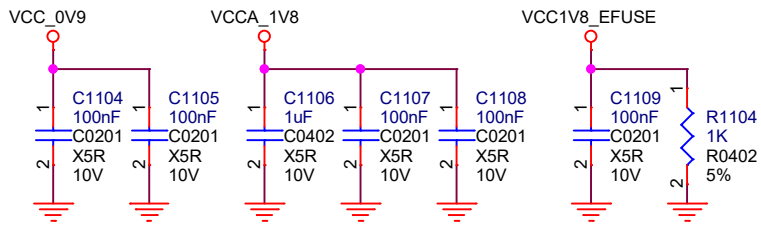
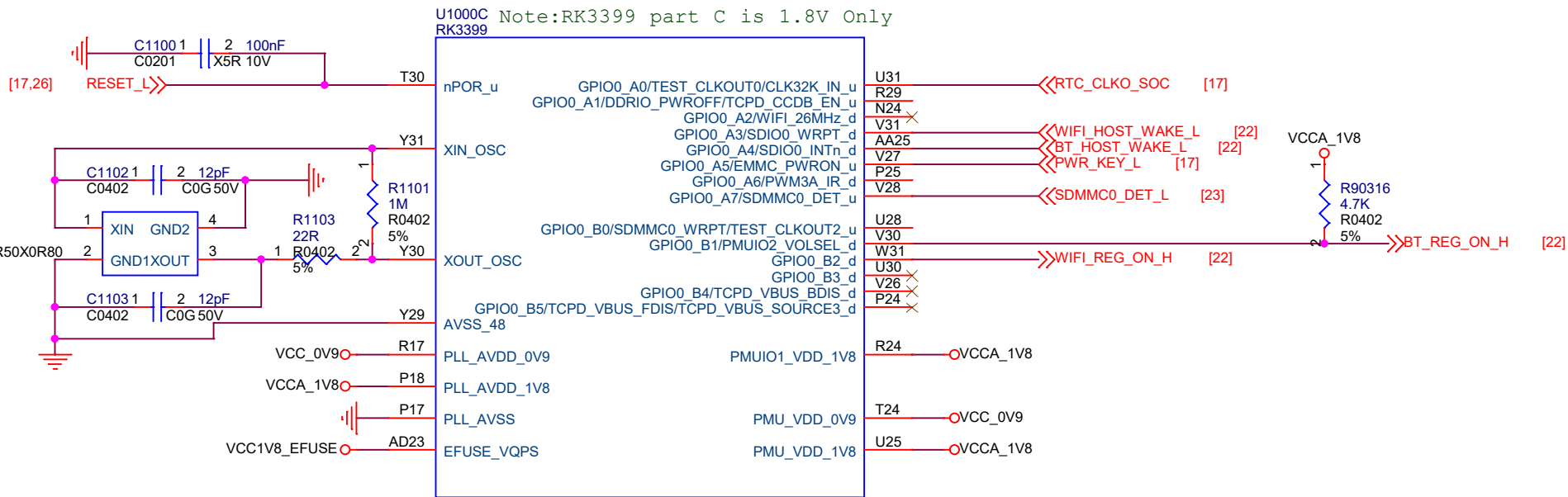

U1000H
RK3399

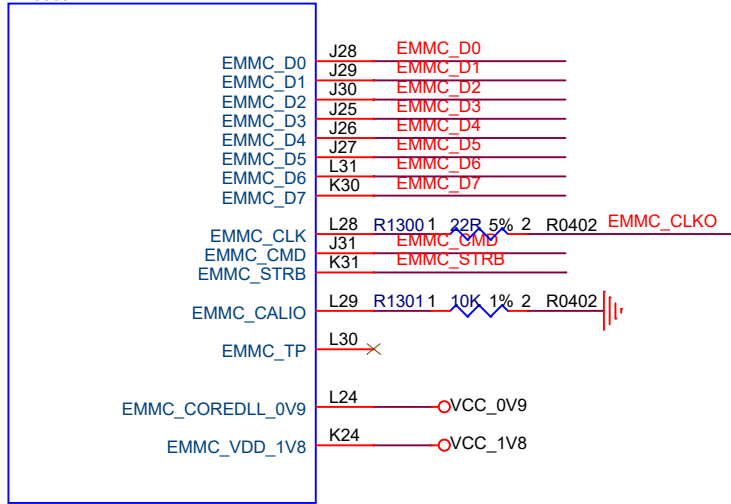

EMMC design rule:

1. Data[0:7]、cmd strobe 为一组并行走线并包地，组内等长要求为 $\pm 100\text{mil}$;
2. Clk 需要单独走线并包地处理，与 data 间的延时小于 20ps ;
3. Max trace length < 3.93 inches;
4. Trace impedance $50\text{ohm} \pm 10\%$;
5. 与其他信号间距遵循原则
6. R1300 靠近 S 放置

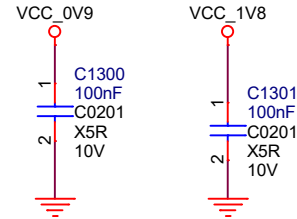
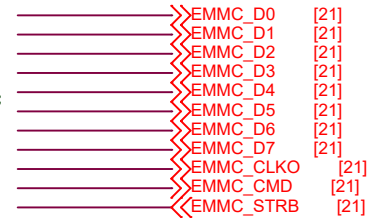

U1000F
RK3399

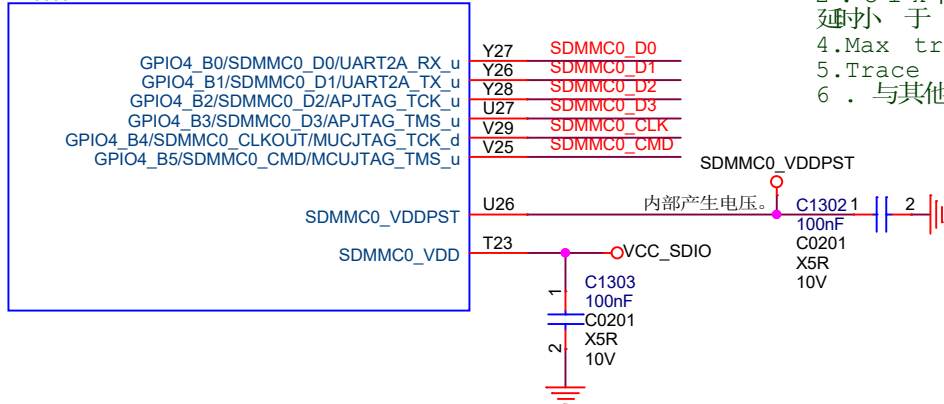

SDMMC design rule:

1. Data[0:3]、cmd 为一组，并行走线并包地，组内等长要求为 $\pm 100\text{mil}$;
2. Clk 需要单独走线并包地处理，与 data 间的延时小于 20ps ;
4. Max trace length < 3.93 inches;
5. Trace impedance $50\text{ohm} \pm 10\%$;
6. 与其他信号间距遵循原则



Size	ROCK PI 4		REV
A4	Page Name:	RK3399 Flash&SDMMC Controller	1.6
Date:	Wednesday, June 16, 2021	Sheet	9 of 27

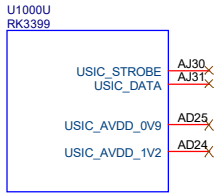

USB2.0

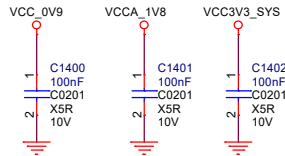
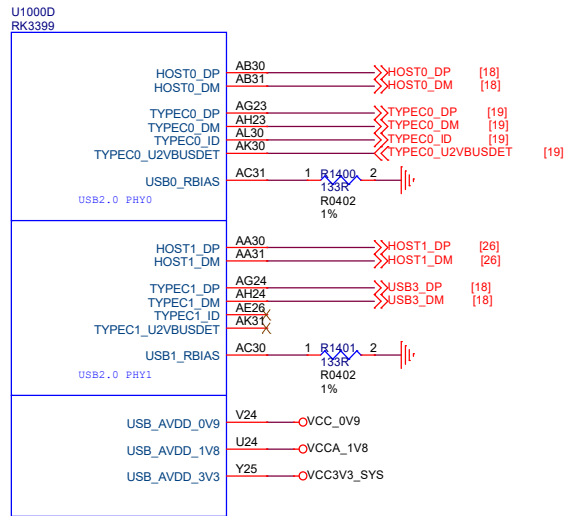

USB2.0 design rule:
 1.Max intra-pair skew < 4 ps;
 2.Max trace length < 6 inchs;
 3.Max allowed via < 6;
 4.Trace impedance 90ohm+/-10%;
 5. 与其他信号间 距遵循 原则

USB3.0

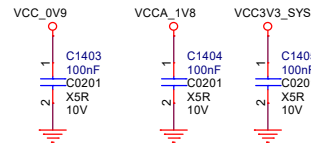
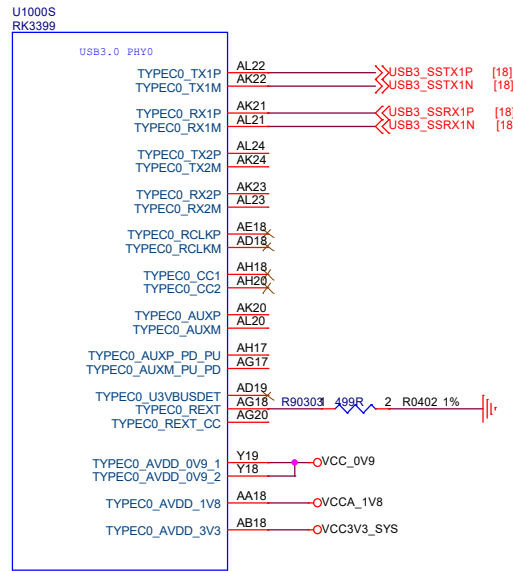

USB3.0 design rule:
 1.Max intra-pair skew < 4 ps;
 2.Max length skew between TX and RX < 1.6 nS;
 3.Max trace length < 6 inchs;
 4.Max allowed via < 4;
 5.Trace impedance 90ohm+/-10%;
 6. 与其他信号间 距遵循 原则

DP design rule:
 1.Max intra-pair skew < 4 ps;
 2.Max trace length < 6 inchs;
 3.Max allowed via < 4;
 4.Trace impedance 90ohm+/-10%;
 5. 与其他信号间 距遵循 原则

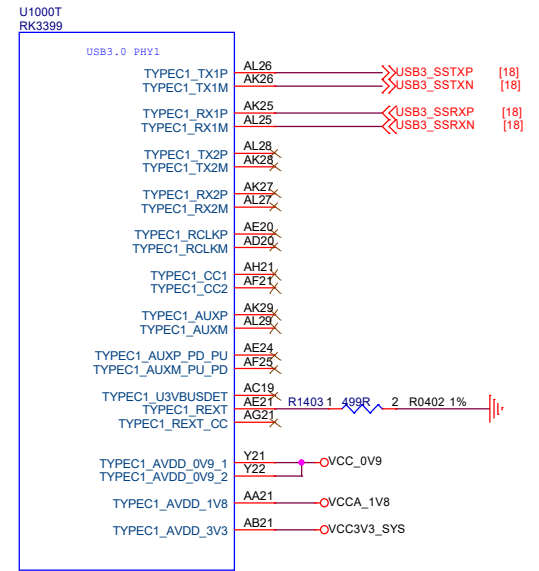

U1000V
RK3399

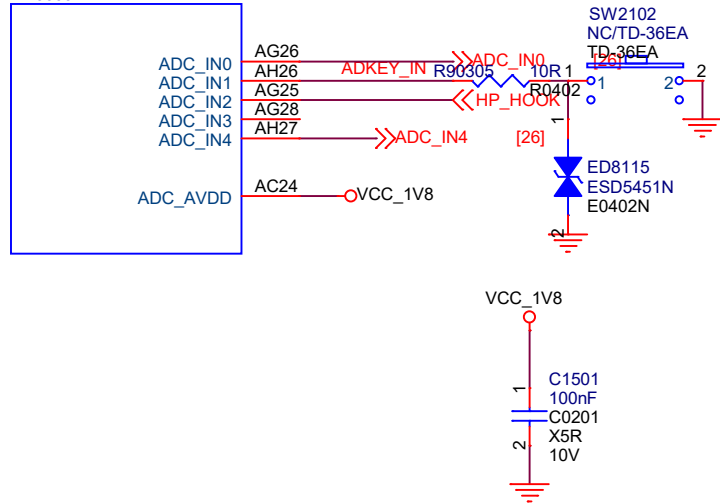

KEY BAORD

Note:
系统上电时，如果 ADKEY_IN 电压为 0V，
则 RK3399 进入 Recover 模式。
量时 R1503, SW1500, ED1501 不用贴片

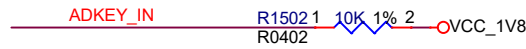

Size	ROCK PI 4	REV
A4	Page Name: RK3399 SARADC/Key	1.6
Date:	Wednesday, June 16, 2021	Sheet 11 of 27

U1000L
RK3399

GPIO2_A0/VOP_D0/CIF_D0/I2C2_SDA_u
GPIO2_A1/VOP_D1/CIF_D1/I2C2_SCL_u
GPIO2_A2/VOP_D2/CIF_D2_d
GPIO2_A3/VOP_D3/CIF_D3_d
GPIO2_A4/VOP_D4/CIF_D4_d
GPIO2_A5/VOP_D5/CIF_D5_d
GPIO2_A6/VOP_D6/CIF_D6_d
GPIO2_A7/VOP_D7/CIF_D7/I2C7_SDA_u
GPIO2_B0/VOP_CLK/CIF_VSYNC/I2C7_SCL_u
GPIO2_B1/SPI2_RXD/CIF_HREF/I2C6_SDA_u
GPIO2_B2/SPI2_TXD/CIF_CLKIN/I2C6_SCL_u
GPIO2_B3/SPI2_CLK/VOP_DEN/CIF_CLKOUTA_u
GPIO2_B4/SPI2_CSn0_u

APIO2_VDDPST
APIO2_VDD

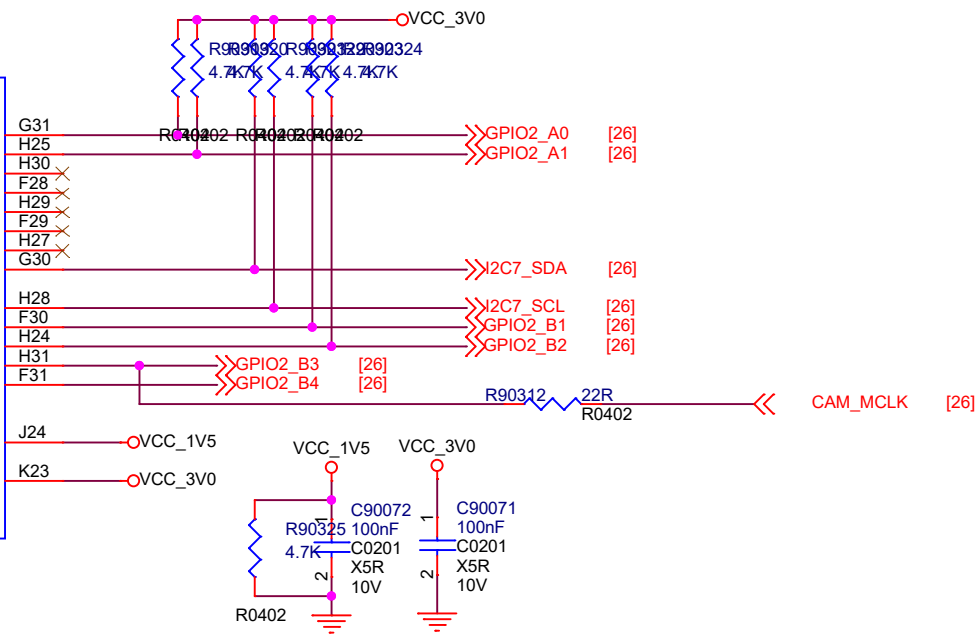

U1000R
RK3399

MIPI_RX0_D0P AK15
MIPI_RX0_D0N AL15
MIPI_RX0_D1P AK14
MIPI_RX0_D1N AL14
MIPI_RX0_CLKP AK13
MIPI_RX0_CLKN AL13
MIPI_RX0_D2P AK12
MIPI_RX0_D2N AL12
MIPI_RX0_D3P AK11
MIPI_RX0_D3N AL11
MIPI_RX0_REXT AF14
MIPI_RX0_AVDD_1V8 AB14

U1000P
RK3399

MIPI_TX1/RX1_D0P AK6
MIPI_TX1/RX1_D0N AL6
MIPI_TX1/RX1_D1P AK7
MIPI_TX1/RX1_D1N AL7
MIPI_TX1/RX1_CLKP AK8
MIPI_TX1/RX1_CLKN AL8
MIPI_TX1/RX1_D2P AK9
MIPI_TX1/RX1_D2N AL9
MIPI_TX1/RX1_D3P AK10
MIPI_TX1/RX1_D3N AL10
MIPI_TX1/RX1_REXT AF11
MIPI_TX1/RX1_AVDD_1V8 AC10

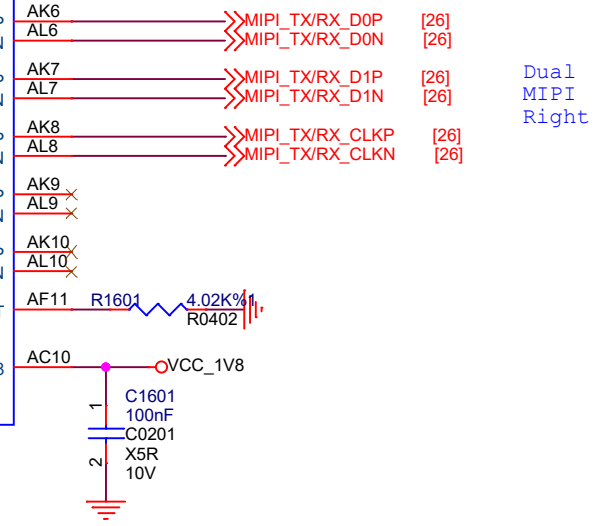

U1000N
RK3399

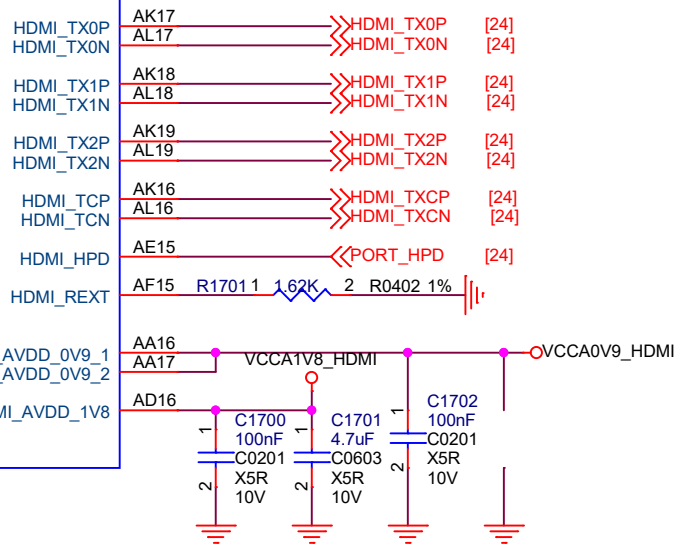

HDMI design rule:

- 1.Max intra-pair skew < 4 ps;
- 2.Max length skew between clk and data < 80 ps;
- 3.Max trace length < 9.8 inches;
- 4.Max allowed via < 4;
- 5.Trace impedance 100ohm+/-10%;
6. 与其他信号间距遵循原则

U1000Q
RK3399

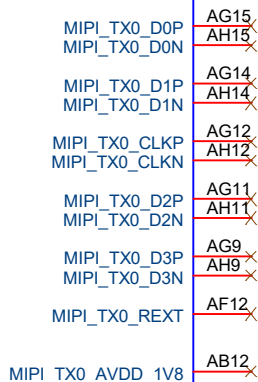

U1000M
RK3399

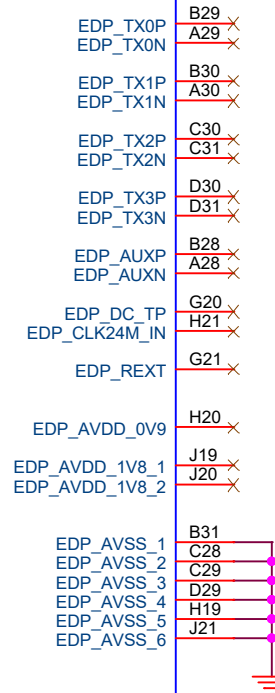

eDP design rule:

- 1.Max intra-pair skew < 4 ps;
- 2.Max trace length < 6 inches;
- 3.Max allowed via < 4;
- 4.Trace impedance 90ohm+/-10%;
5. 与其他信号间距遵循原则;

MIPI design rule:

- 1.Max intra-pair skew < 4 ps;
- 2.Max length skew between clk and data < 7ps;
- 3.Max trace length < 7.2 inches;
- 4.Max allowed via < 4;
- 5.Trace impedance 100ohm+/-10%;
6. 与其他信号间距遵循原则



U10000
RK3399

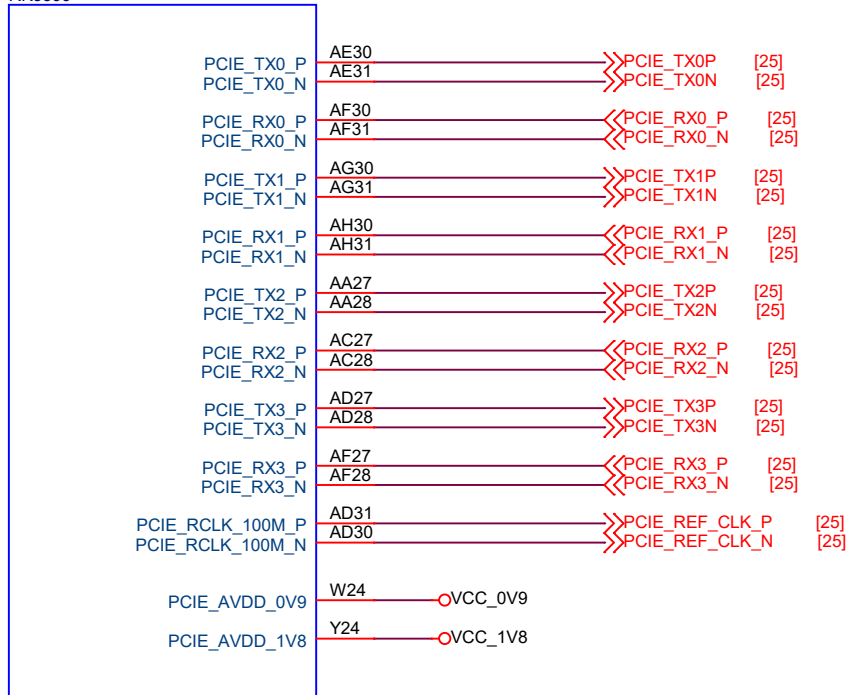

PCIE design rule:

1. Max intra-pair skew < 4ps;
2. Max inter-pair skew < 1.6 ns;
3. Max trace length < 14 inches;
4. Max allowed via < 4;
5. Trace impedance 100ohm+/-10%;
6. 与其他信号间距遵循原则

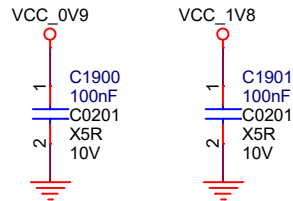



Size	ROCK PI 4	REV
A4	Page Name: RK3399 PCIE	1.6
Date:	Wednesday, June 16, 2021	Sheet 15 of 27

DC IN&SYSTEM Power

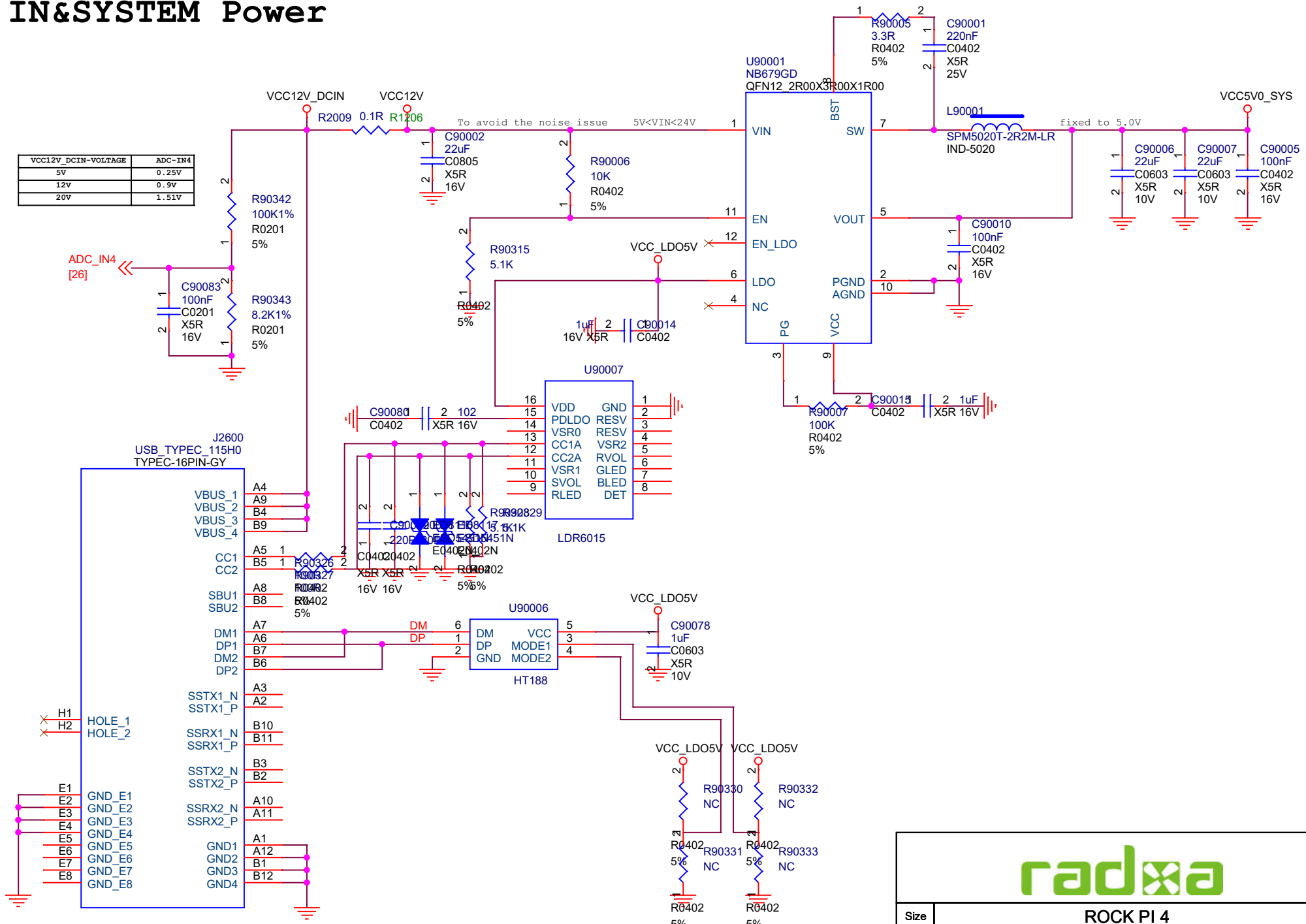

PMIC

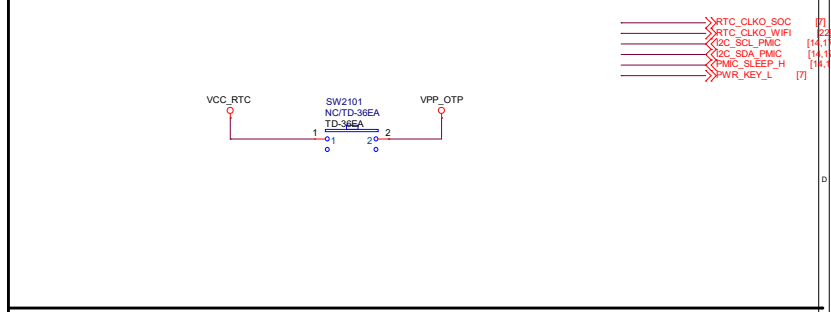
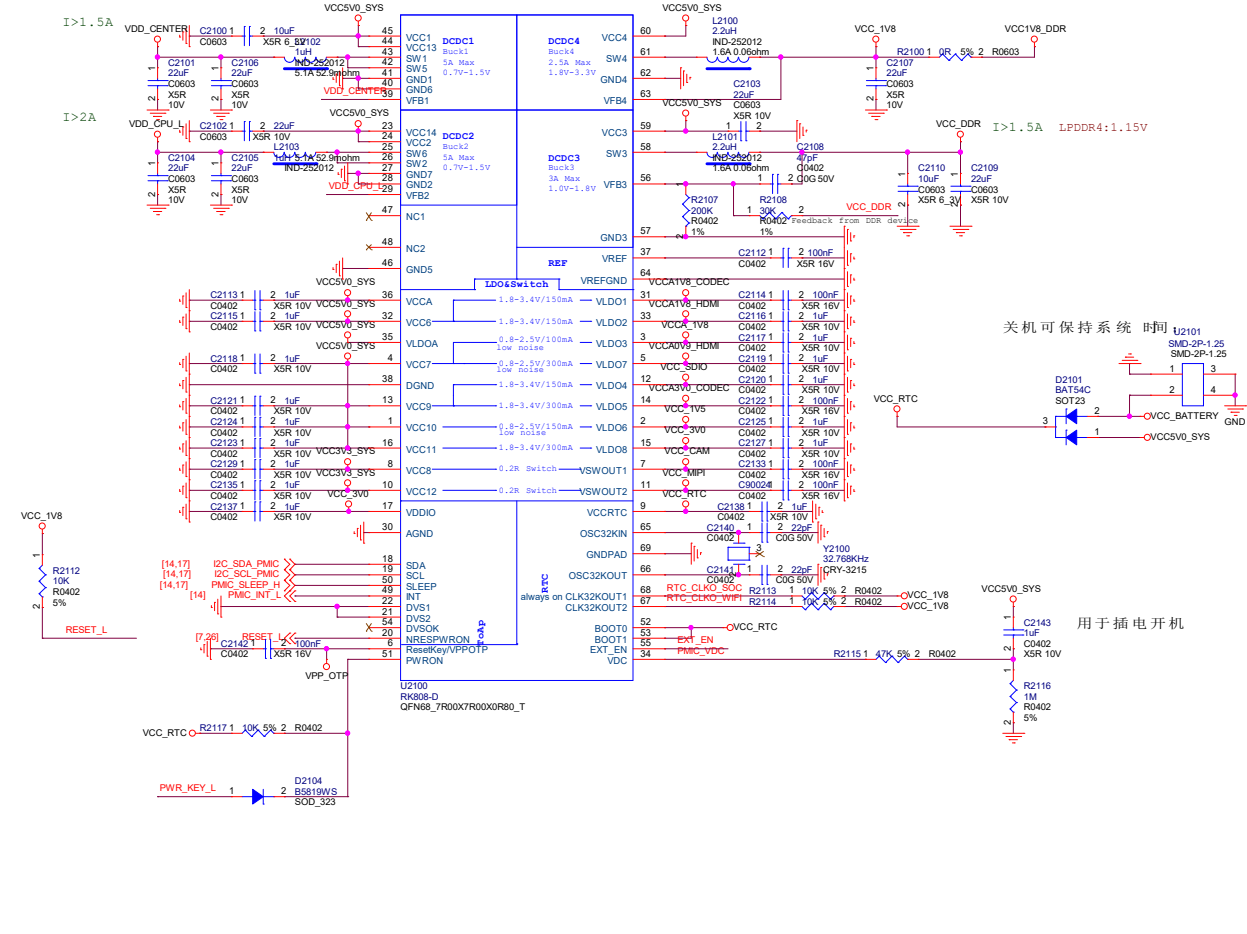

VDD_CPU_B power

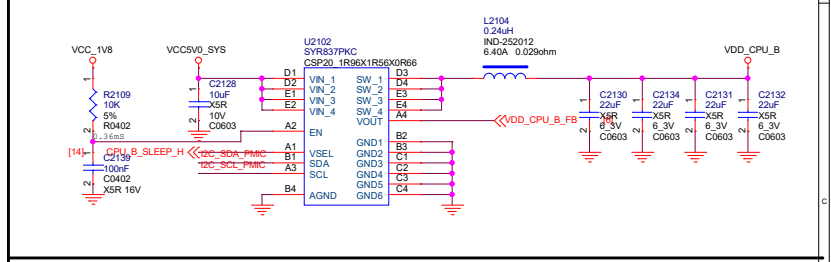

VDD_GPU power

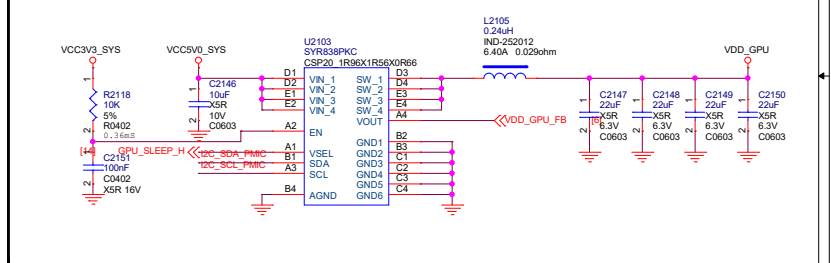

VCC_0V9 power

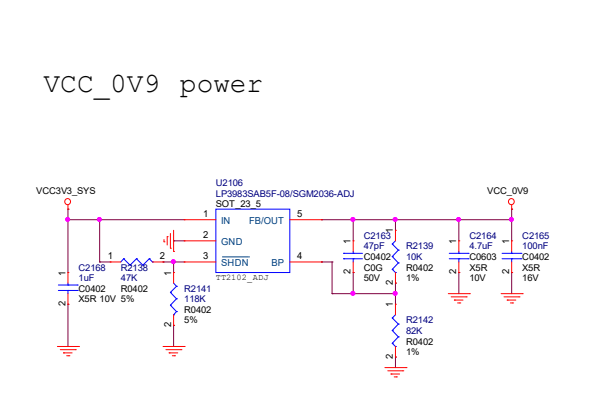

VDD_LOG power

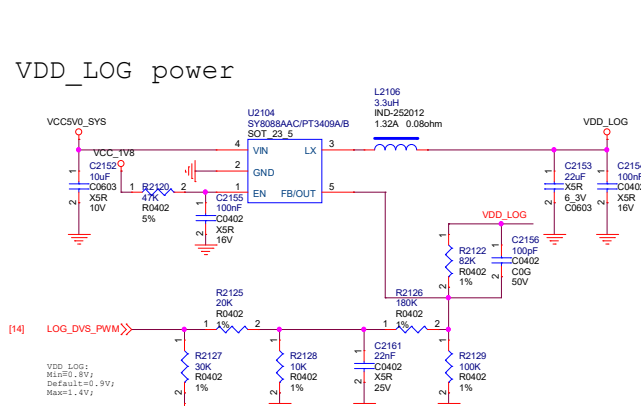

VCC3V3_SYS power

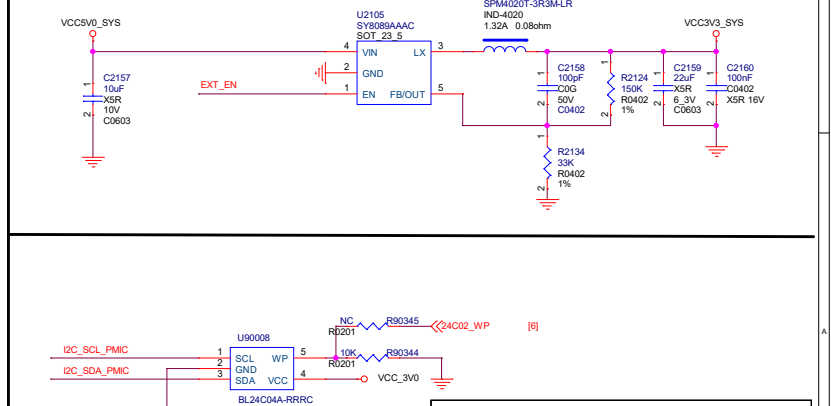

radxa
ROCK PI 4
 Part Name: Power-PMIC RK808-D
 Date: Wednesday, June 16, 2021
 Sheet 17 of 27

USB3.0 OTG port

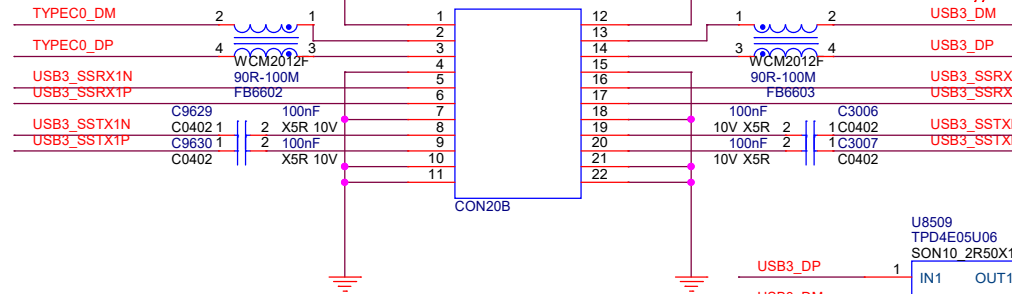
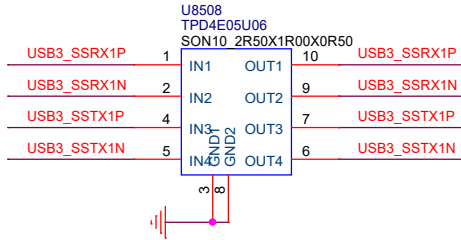
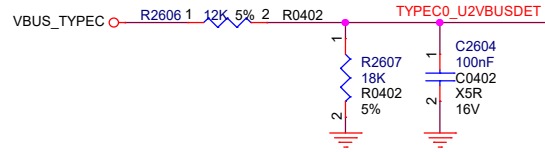

- >>TYPEC0_ID [10]
- >>TYPEC0_DP [10]
- >>TYPEC0_DM [10]
- >>VCC5V0_TYPEC0_EN [14]
- >>TYPEC0_U2VBUSDET [10]
- >>USB3_SSTX1P [18]
- >>USB3_SSTX1N [18]
- >>USB3_SSRX1P [18]
- >>USB3_SSRX1N [18]
- >>HOST0_DP [10]
- >>HOST0_DM [10]
- >>VCC5V0_HOST_EN [14]
- >>USB3_DP [10]
- >>USB3_DM [10]
- >>USB3_SSTXP [10]
- >>USB3_SSTXN [10]
- >>USB3_SSRXP [10]
- >>USB3_SSRXN [10]
- >>HOST1_DP [26]
- >>HOST1_DM [26]

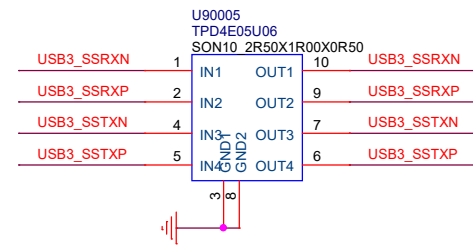
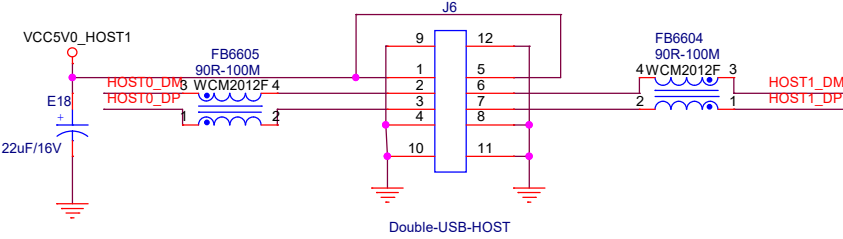
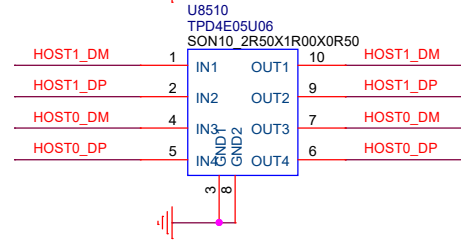
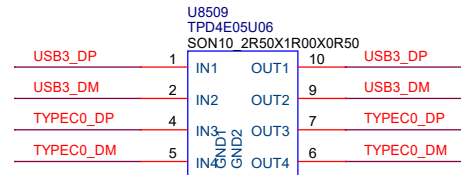
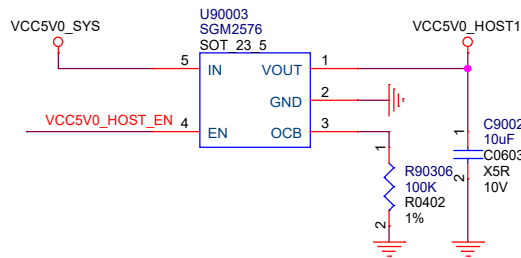
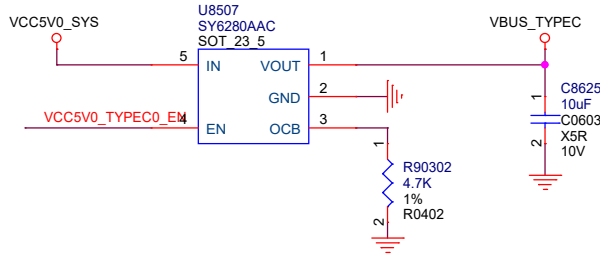

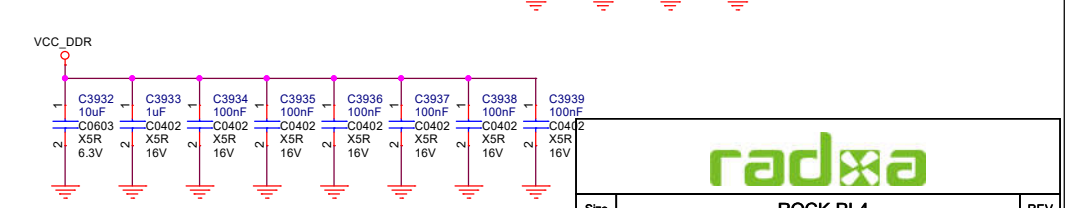
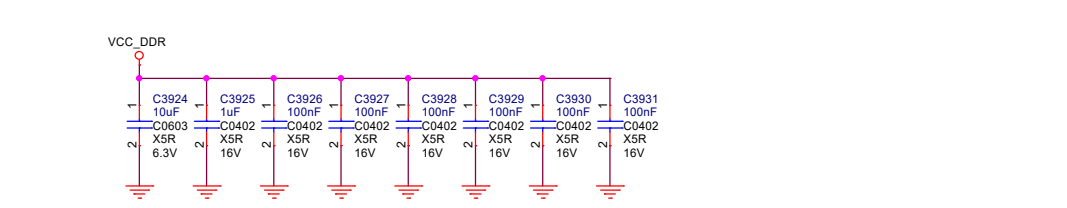
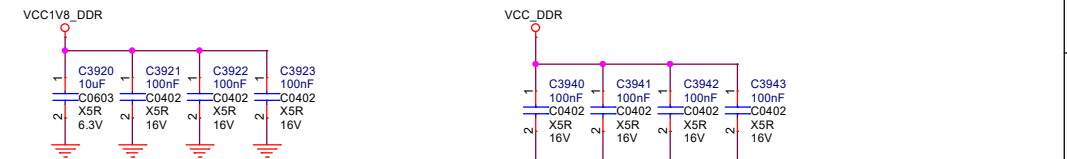
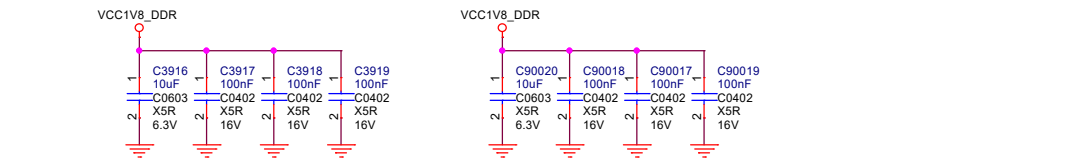
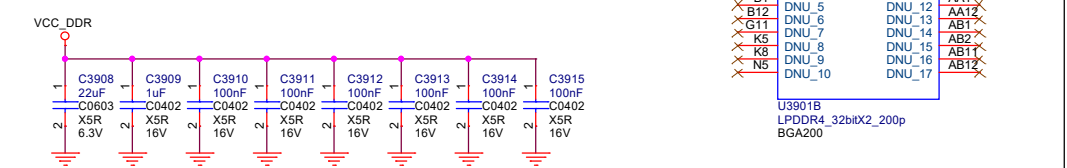
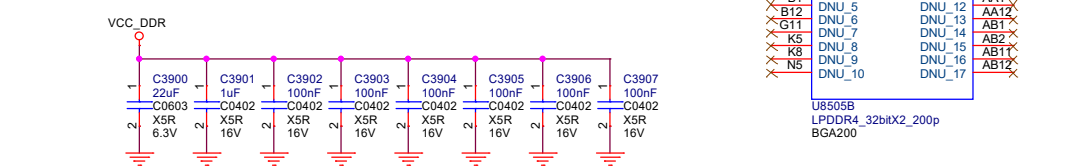
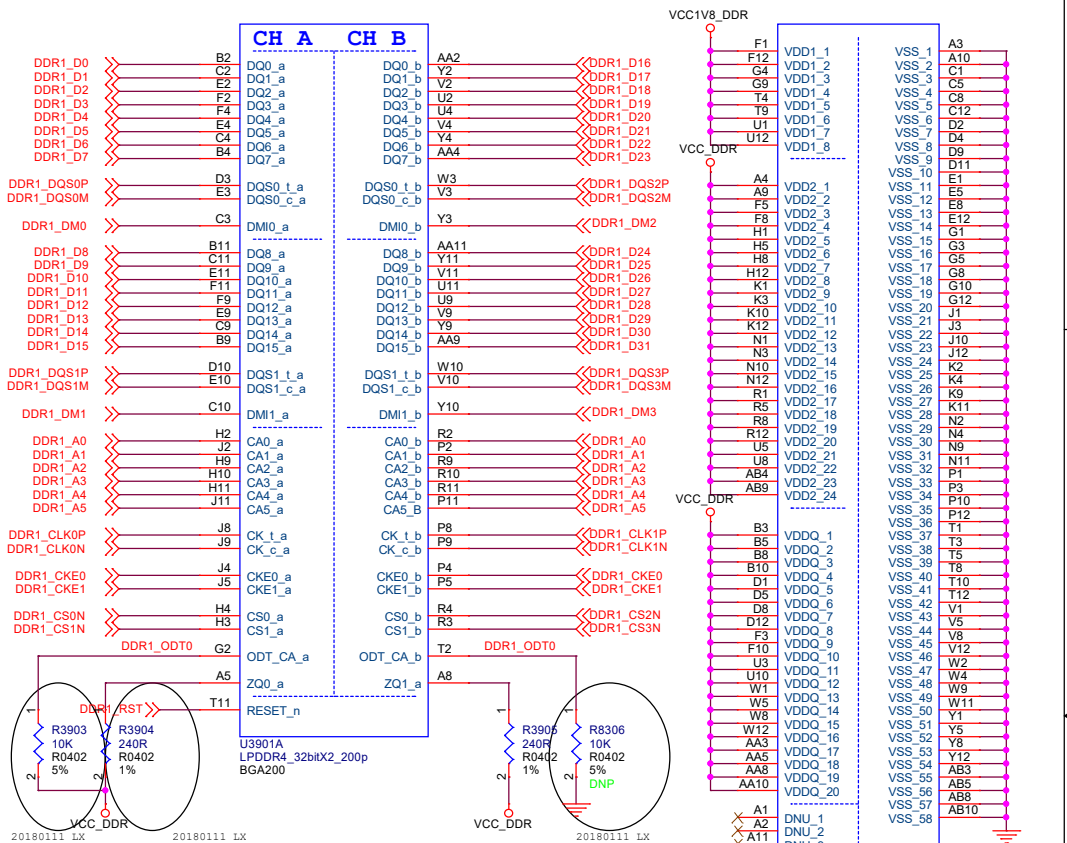
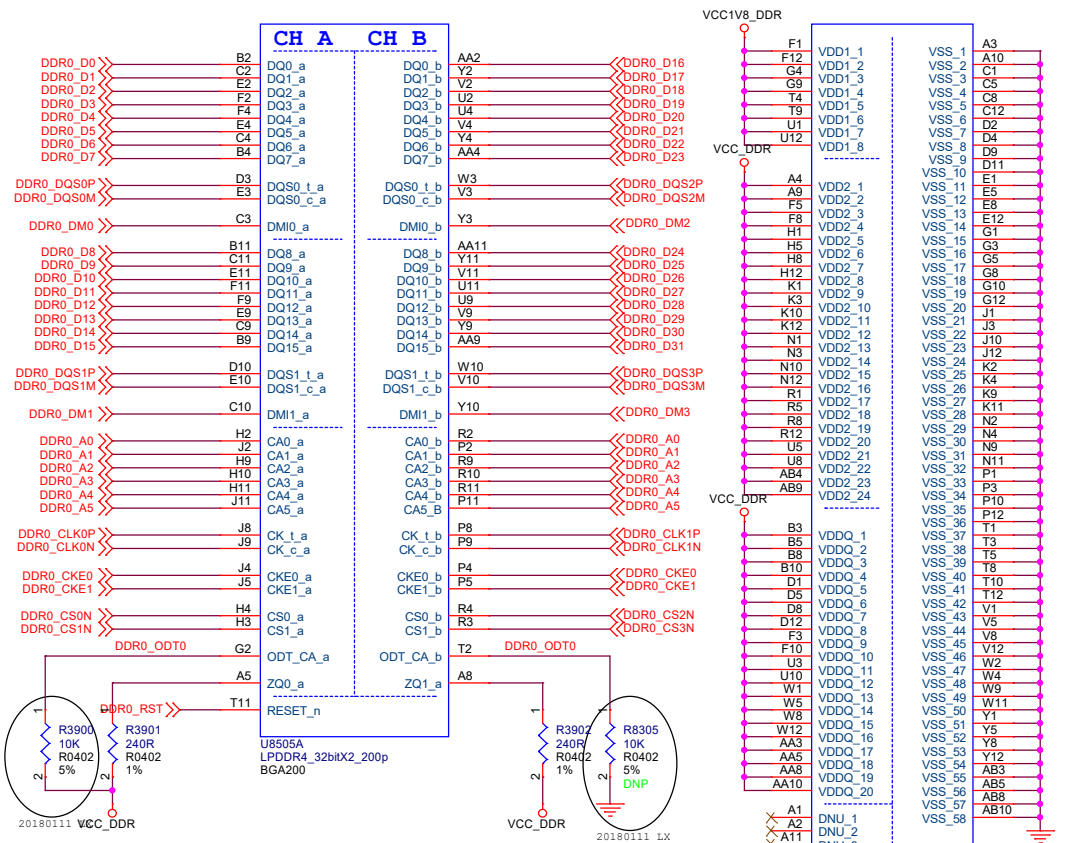

eMMC FLASH



eMMC

PCB Decal:169pin balls Type(BGA)

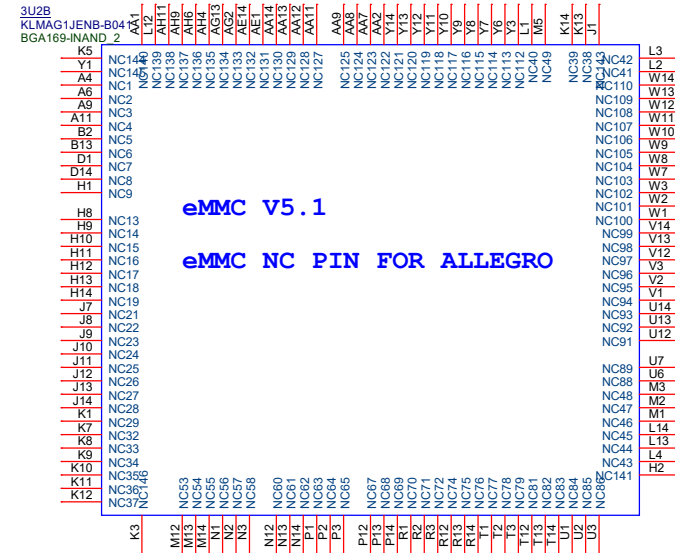
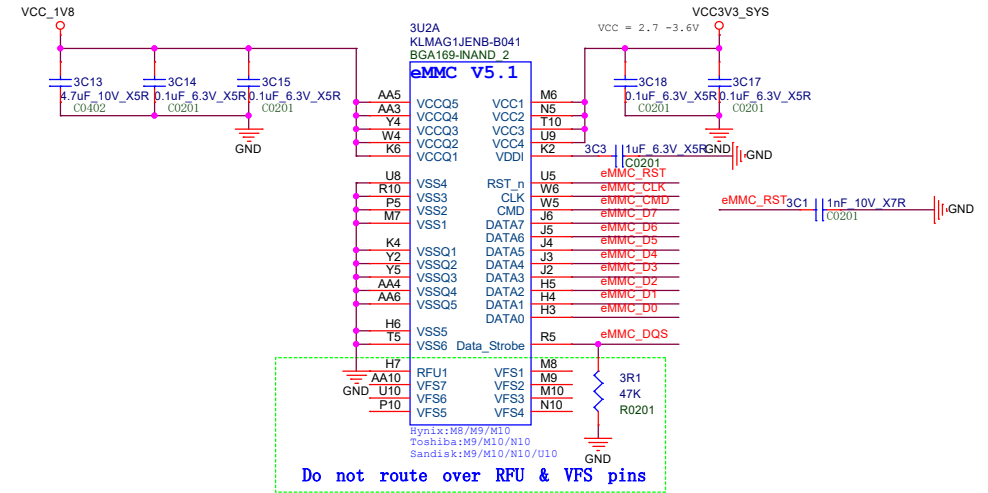

eMMC V5.1

eMMC NC PIN FOR ALLEGRO

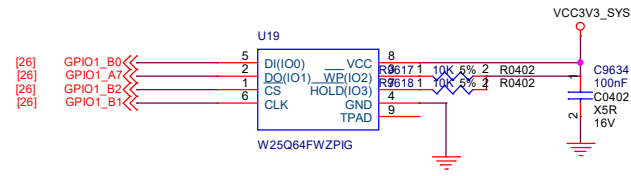
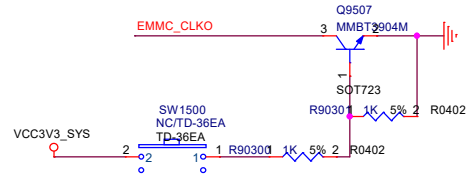
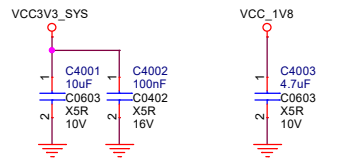

Size	ROCK PI 4		REV
A3	Page Name:	Memory-eMMC	1.6
Date:	Wednesday, June 16, 2021		Sheet 21 of 27

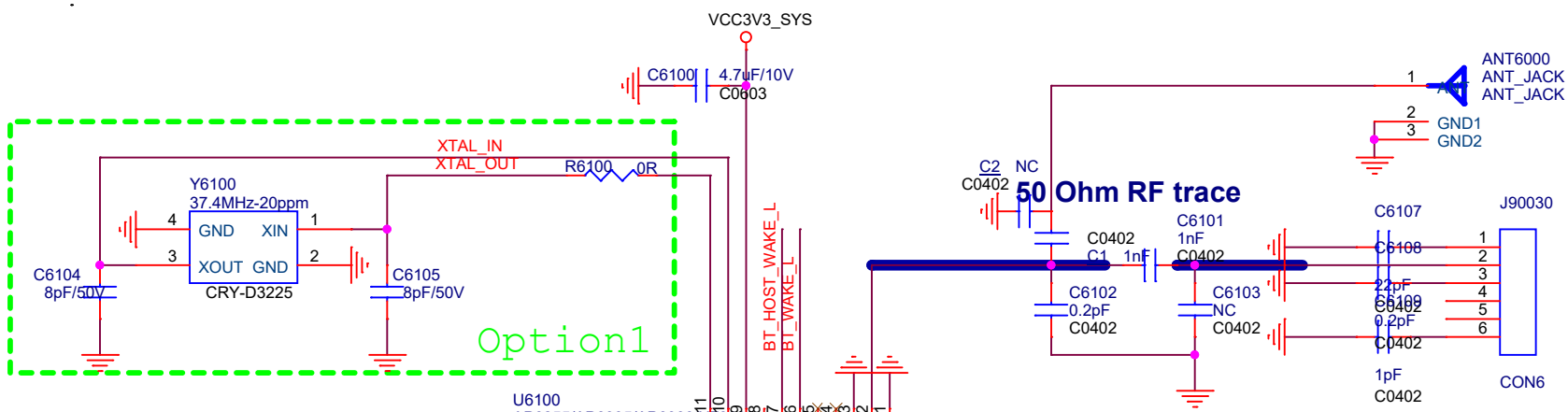

SDIO0_D0	[14]
SDIO0_D1	[14]
SDIO0_D2	[14]
SDIO0_D3	[14]
SDIO0_CMD	[14]
SDIO0_CLK	[14]
UART0_RTS	[14]
UART0_TXD	[14]
UART0_RXD	[14]
UART0_CTS	[14]
BT_HOST_WAKE_L	[7]
BT_WAKE_L	[14]
BT_REG_ON_H	[7]
WIFI_REG_ON_H	[7]
WIFI_HOST_WAKE_L	[7]
RTC_CLKO_WIFI	[17,22]

WIFI_REG_ON	121	WL_REG_ON
WIFI_HOST_WAKE_L	131	WL_HOST_WAKE
SDIO0_D2	14	SDIO_DATA_2
SDIO0_D3	15	SDIO_DATA_3
SDIO0_CMD	16	SDIO_DATA_CMD
/SDIO_CLK	17	SDIO_DATA_CLK
SDIO0_D0	18	SDIO_DATA_0
SDIO0_D1	19	SDIO_DATA_1
	20	SDIO_DATA_1
	21	GND
	22	VIN_LDO_OUT
	22	VDDIO

N_VDDSWP_IN	47	
N_VDDSWP_OUT	46	
N_VDDSWPIO	45	
UART_CTS_N	44	UART0_RTS
UART_RXD	43	UART0_TXD
UART_TXD	42	UART0_RXD
UART_RTS_N	41	UART0_CTS
TX1	40	
TX2	39	
N_REG_PU	38	
N_I2C_SCL	37	
GND	36	
N_I2C_SDA	35	
BT_RST_N	34	BT_REG_ON_H

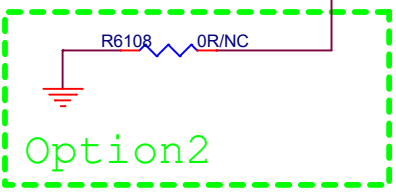
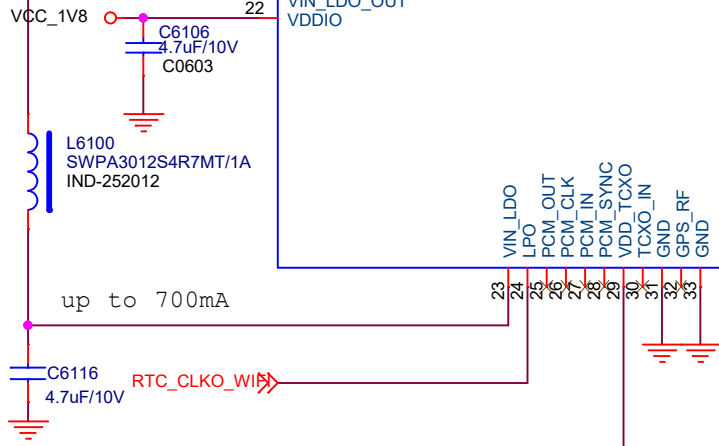

/SDIO_CLK R6306 1 33R 5% 2 R0402 SDIO0_CLK

ROCK PI 4		REV
A4	Page Name: WIFI/BTMIMO-AP6354	1.6
Date: Wednesday, June 16, 2021	Sheet 22 of 27	

TF CARD

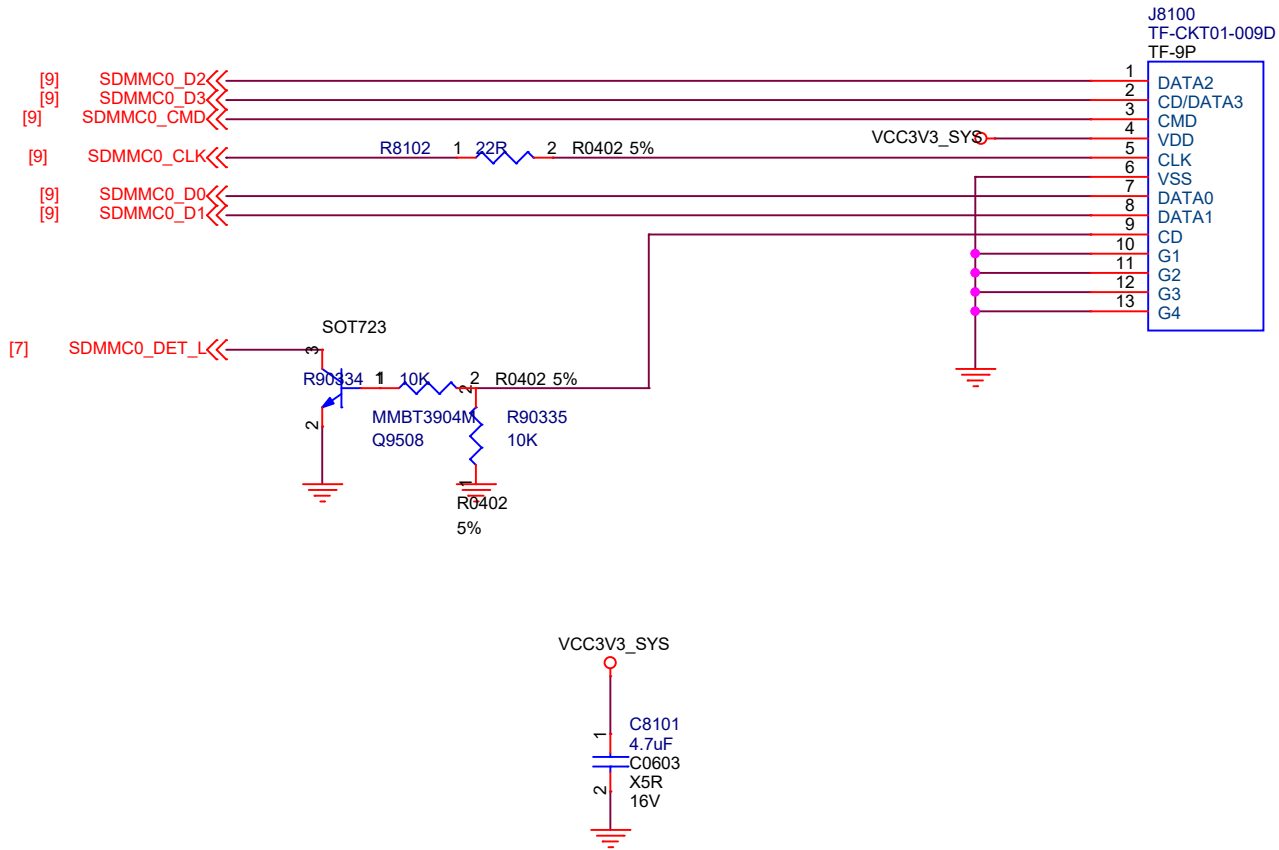

Size	ROCK PI 4	REV
A4	Page Name: TF Card	1.6
Date: Wednesday, June 16, 2021	Sheet 23 of 27	

HDMI Output

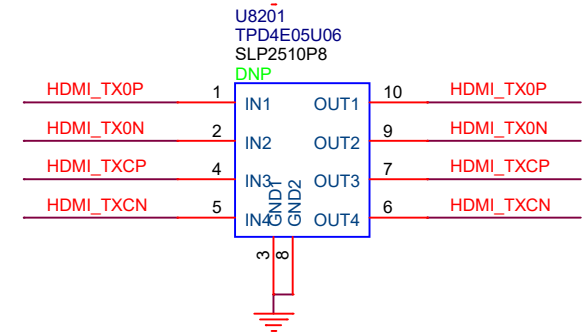
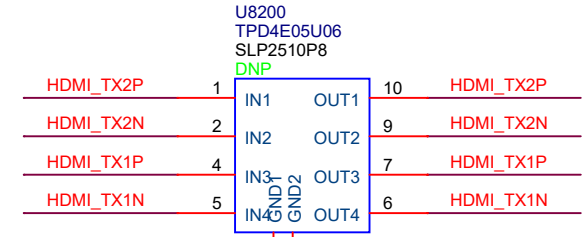
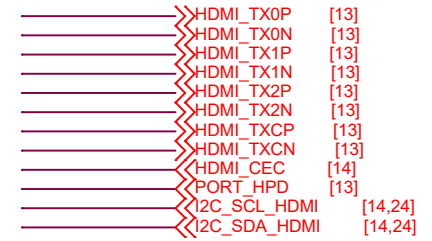
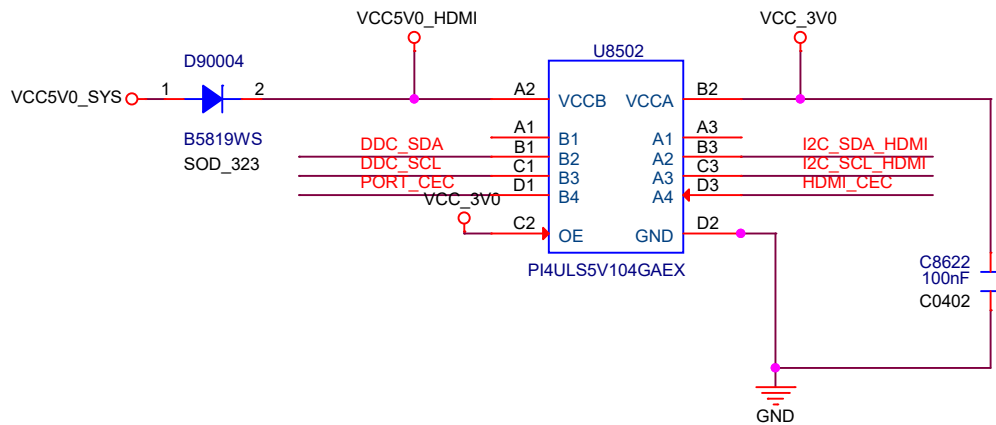
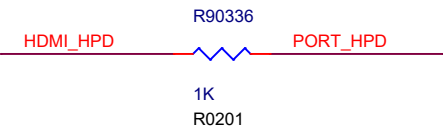
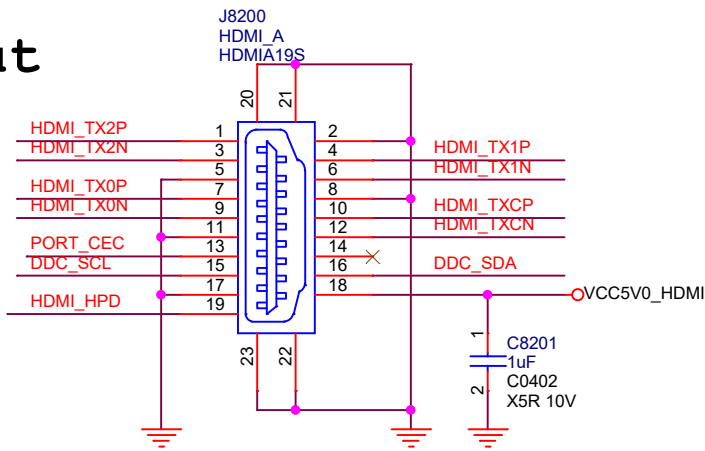

Size	ROCK PI 4		REV
A4	Page Name:	HDMI Output	1.6
Date:	Wednesday, June 16, 2021	Sheet	24 of 27

PCIe NGFF/M.2

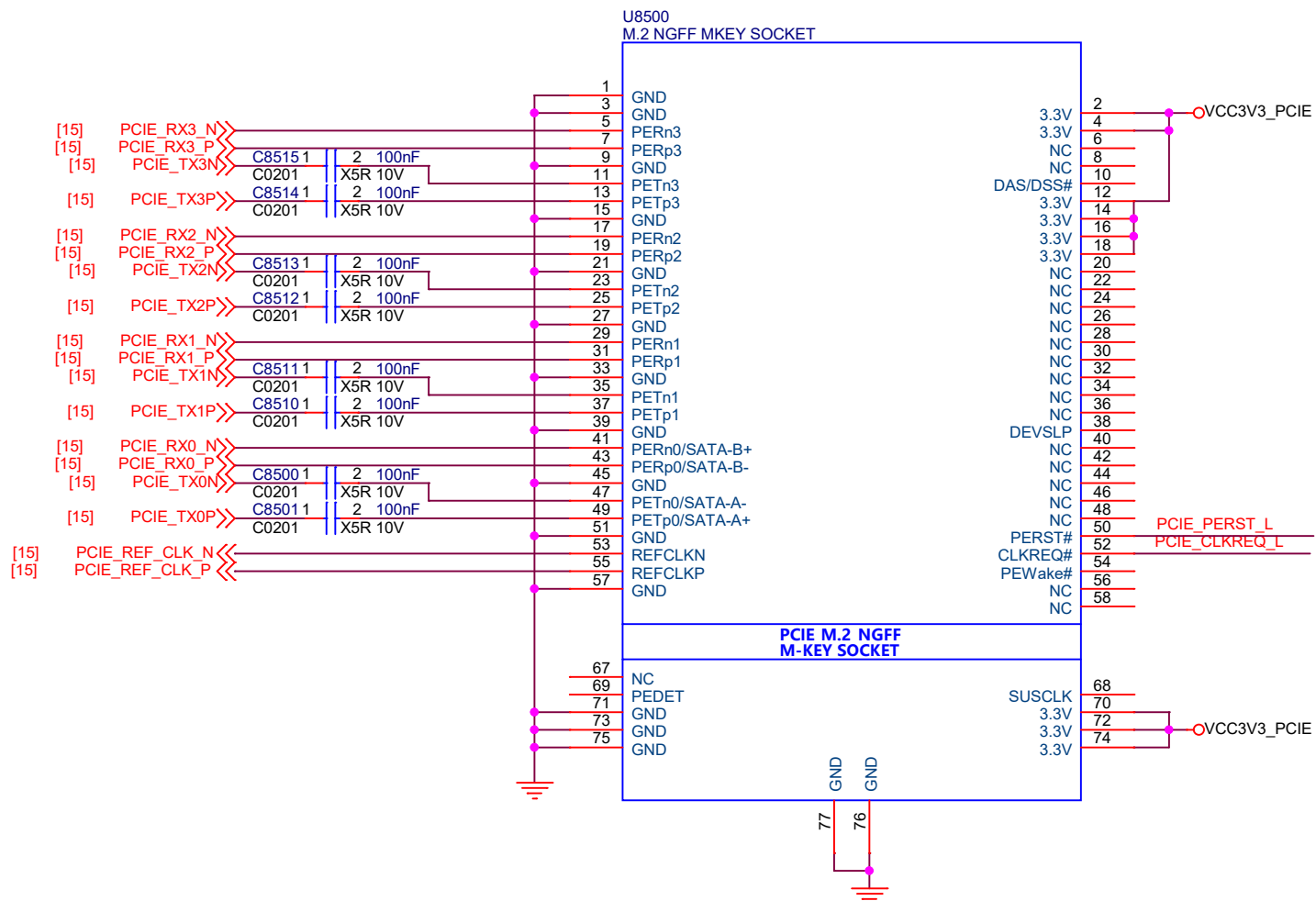

[12] PCIe_PERST_L
[14] PCIe_CLKREQ_L

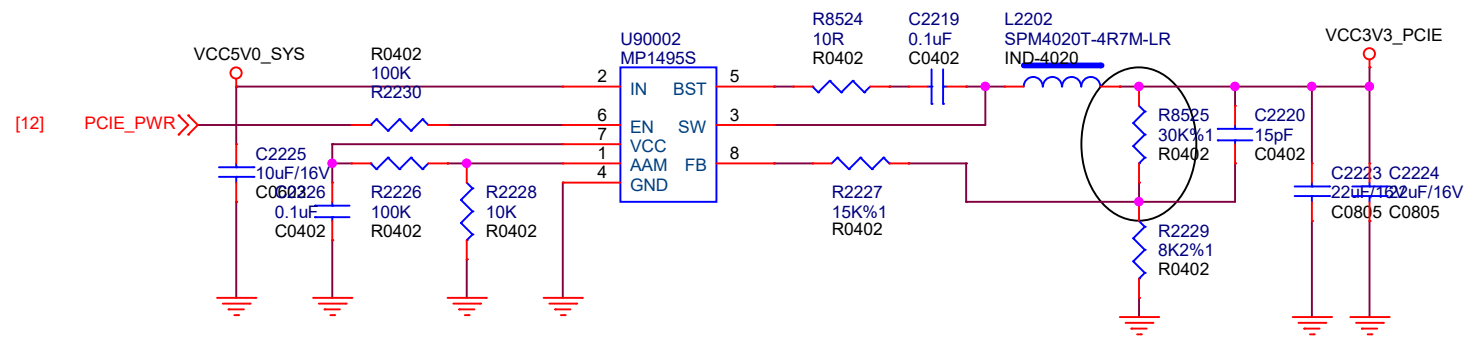

VCC3V3_PCIE Note: 3.3V 供电 至少 5A

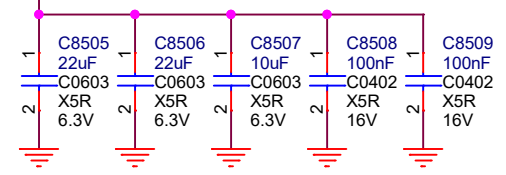

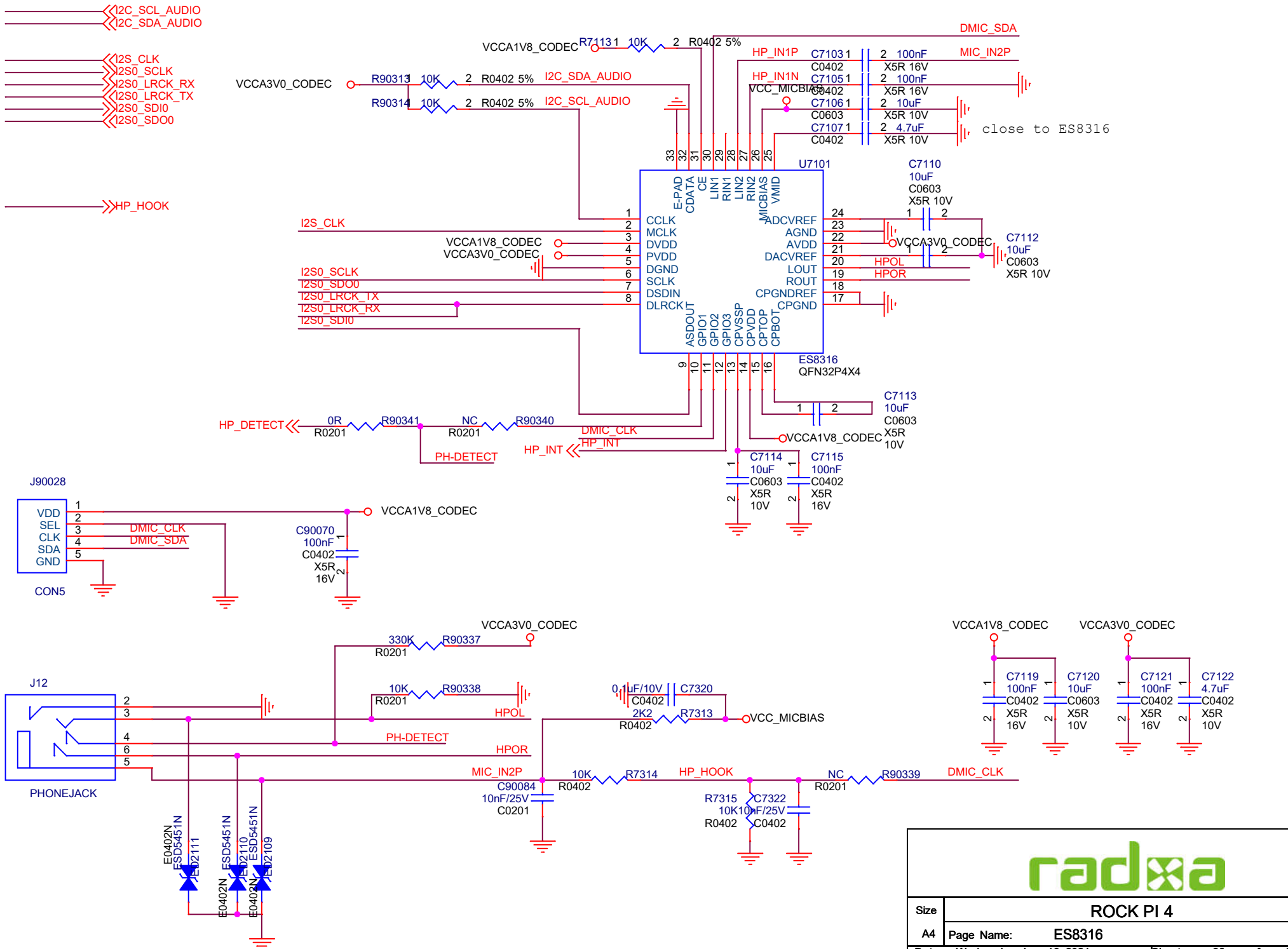

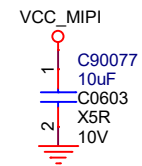
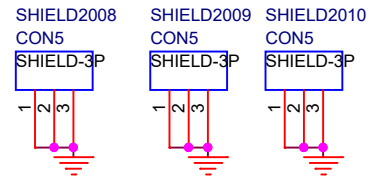
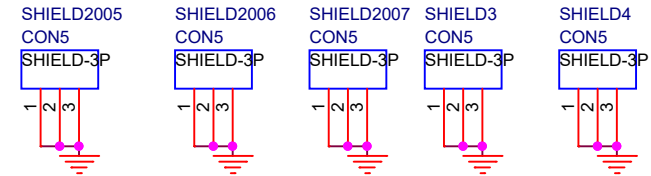
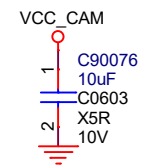
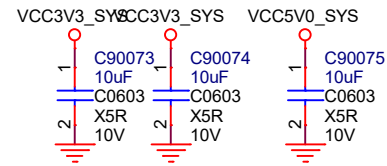
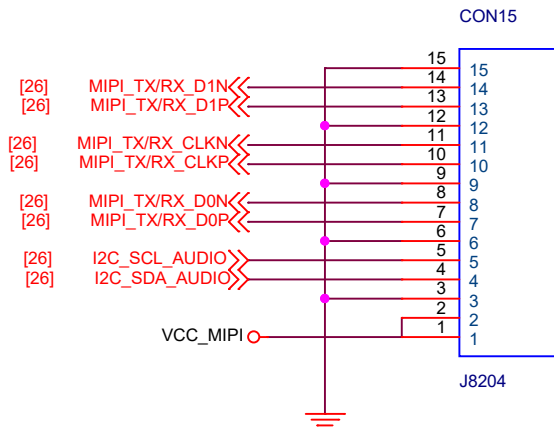
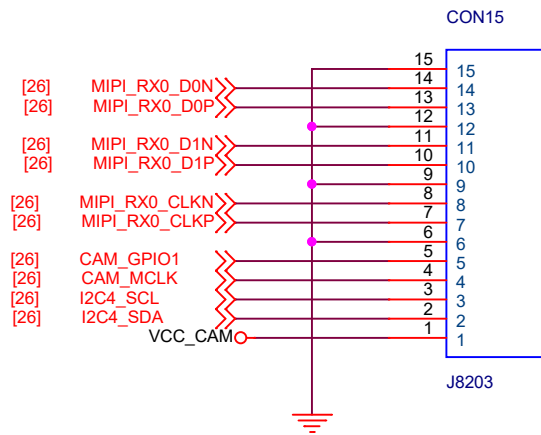
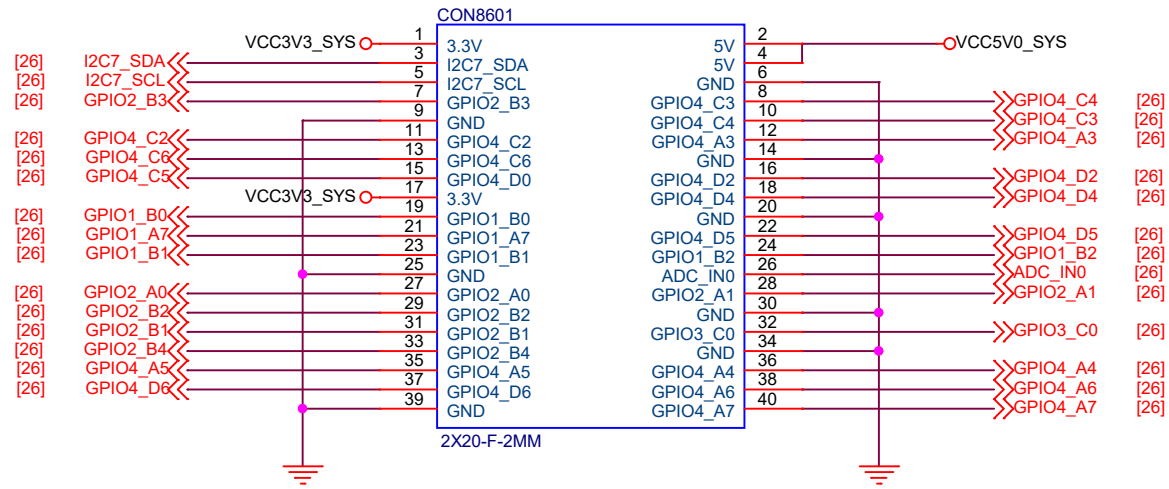

radxa

Size	ROCK PI 4		REV
A4	Page Name:	CONNECTOR	1.6
Date:	Wednesday, June 16, 2021	Sheet	27 of 27