

TEST REPORT

Report No.: BCTC2110851942-4E

Applicant: ROCKPI TRADING LIMITED

Product Name: ROCK Pi 4

Model/Type Ref.: ROCK Pi 4 MODEL B+

Tested Date: 2021-10-25 to 2021-11-03

Issued Date: 2021-11-03

Shenzhen BCTC Testing Co., Ltd.

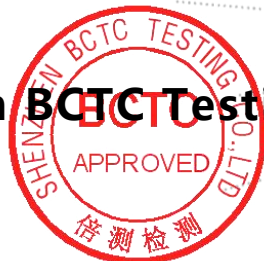

FCC ID:2A3PA-ROCKPI4

Product Name: ROCK Pi 4
Trademark: N/A
Model/Type Ref.: ROCK Pi 4 MODEL B+
ROCK Pi 4 MODEL A, ROCK Pi 4 MODEL A+, ROCK Pi 4 MODEL B
Prepared For: ROCKPI TRADING LIMITED
Address: Room 11, 27/f, Ga wah international centre, 191 Javaroad, north point,
Hong Kong, China
Manufacturer: ROCKPI TRADING LIMITED
Address: Room 11, 27/f, Ga wah international centre, 191 Javaroad, north point,
Hong Kong, China
Prepared By: Shenzhen BCTC Testing Co., Ltd.
Address: 1-2/F., Building B, Pengzhou Industrial Park, No.158, Fuyuan 1st Road, Tangwei,
Fuhai Subdistrict, Bao'an District, Shenzhen, Guangdong, China
Sample Received Date: 2021-10-25
Sample tested Date: 2021-10-25 to 2021-11-03
Issue Date: 2021-11-03
Report No.: BCTC2110851942-4E
FCC Part15 15.407
Test Standards: ANSI C63.10-2013
KDB 662911 D01 v02r01
KDB 789033 D02 v02r01
Test Results: PASS

Tested by:



Kelsey Tan/ Project Handler

Approved by:



Zero Zhou/Reviewer

The test report is effective only with both signature and specialized stamp. This result(s) shown in this report refer only to the sample(s) tested. Without written approval of Shenzhen BCTC Testing Co., Ltd, this report can't be reproduced except in full. The tested sample(s) and the sample information are provided by the client.

Table Of Content

| | Page |
|--|------|
| Test Report Declaration | |
| 1. Version | 5 |
| 2. Test Summary | 6 |
| 3. Measurement Uncertainty | 7 |
| 4. Product Information And Test Setup | 8 |
| 4.1 Product Information | 8 |
| 4.2 Test Setup Configuration | 8 |
| 4.3 Support Equipment | 9 |
| 4.4 Channel List | 9 |
| 4.5 Test Mode | 10 |
| 4.6 Table Of Parameters Of Text Software Setting | 10 |
| 5. Test Facility And Test Instrument Used | 11 |
| 5.1 Test Facility | 11 |
| 5.2 Test Instrument Used | 11 |
| 6. Conducted Emissions | 13 |
| 6.1 Block Diagram Of Test Setup | 13 |
| 6.2 Limit | 13 |
| 6.3 Test Procedure | 13 |
| 6.4 EUT Operating Conditions | 13 |
| 6.5 Test Result | 14 |
| 7. Radiated Emissions | 16 |
| 7.1 Block Diagram Of Test Setup | 16 |
| 7.2 Limit | 17 |
| 7.3 Test Procedure | 18 |
| 7.4 EUT Operating Conditions | 19 |
| 7.5 Test Result | 19 |
| 8. Power Spectral Density Test | 28 |
| 8.1 Block Diagram Of Test Setup | 28 |
| 8.2 Limit | 28 |
| 8.3 Test Procedure | 29 |
| 8.4 EUT Operating Conditions | 29 |
| 8.5 Test Result | 30 |
| 9. 26dB & 99% Emission Bandwidth | 34 |
| 9.1 Block Diagram Of Test Setup | 34 |
| 9.2 Limit | 34 |
| 9.3 Test Procedure | 34 |
| 9.4 EUT Operating Conditions | 34 |
| 9.5 Test Result | 35 |
| 10. Maximum Conducted Output Power | 39 |

| | | |
|------|---------------------------------|----|
| 10.1 | Block Diagram Of Test Setup | 39 |
| 10.2 | Limit | 39 |
| 10.3 | Test Procedure | 39 |
| 10.4 | EUT Operating Conditions | 40 |
| 10.5 | Test Result | 41 |
| 11. | Out Of Band Emissions | 42 |
| 11.1 | Block Diagram Of Test Setup | 42 |
| 11.2 | Limit | 42 |
| 11.3 | Test Procedure | 42 |
| 11.4 | EUT Operating Conditions | 42 |
| 11.5 | Test Result | 43 |
| 12. | Spurious RF Conducted Emissions | 46 |
| 12.1 | Block Diagram Of Test Setup | 46 |
| 12.2 | Limit | 46 |
| 12.3 | Test Procedure | 46 |
| 12.4 | Test Result | 46 |
| 13. | Frequency Stability Measurement | 54 |
| 13.1 | Block Diagram Of Test Setup | 54 |
| 13.2 | Limit | 54 |
| 13.3 | Test Procedure | 54 |
| 13.4 | Test Result | 55 |
| 14. | Antenna Requirement | 58 |
| 14.1 | Limit | 58 |
| 14.2 | EUT Antenna | 58 |
| 15. | EUT Photographs | 59 |
| 16. | EUT Test Setup Photographs | 60 |

(Note: N/A Means Not Applicable)

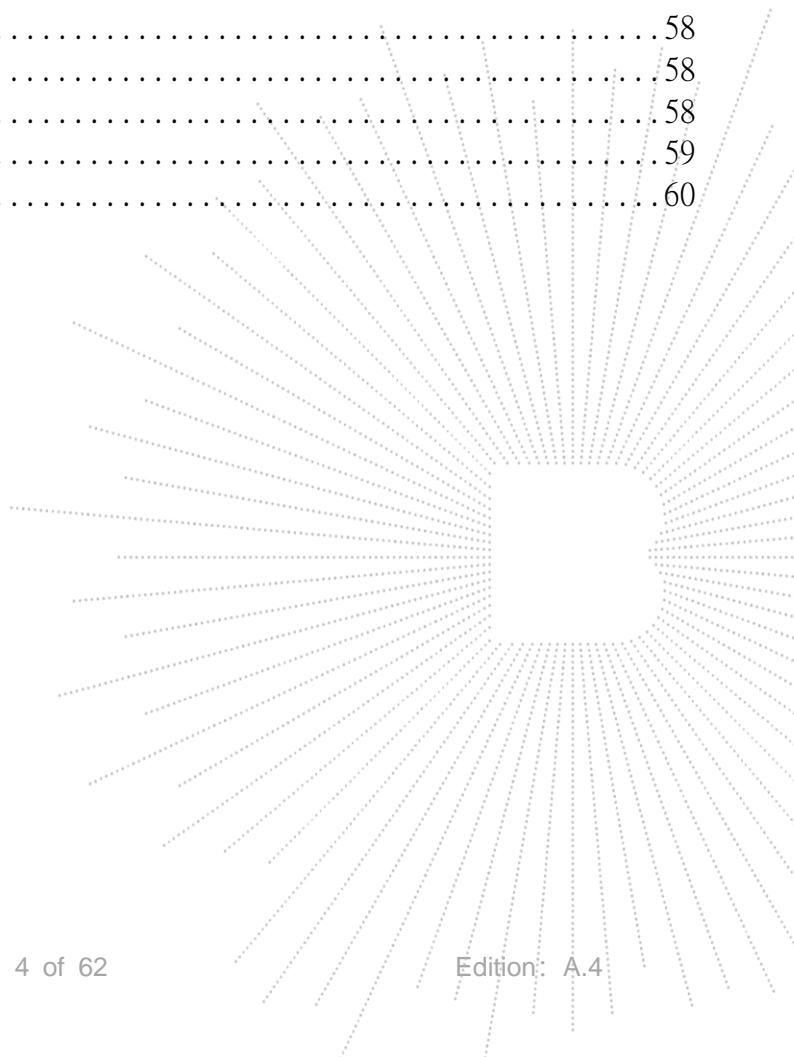

1. Version

| Report No. | Issue Date | Description | Approved |
|-------------------|-------------------|--------------------|-----------------|
| BCTC2110851942-4E | 2021-11-03 | Original | Valid |
| | | | |

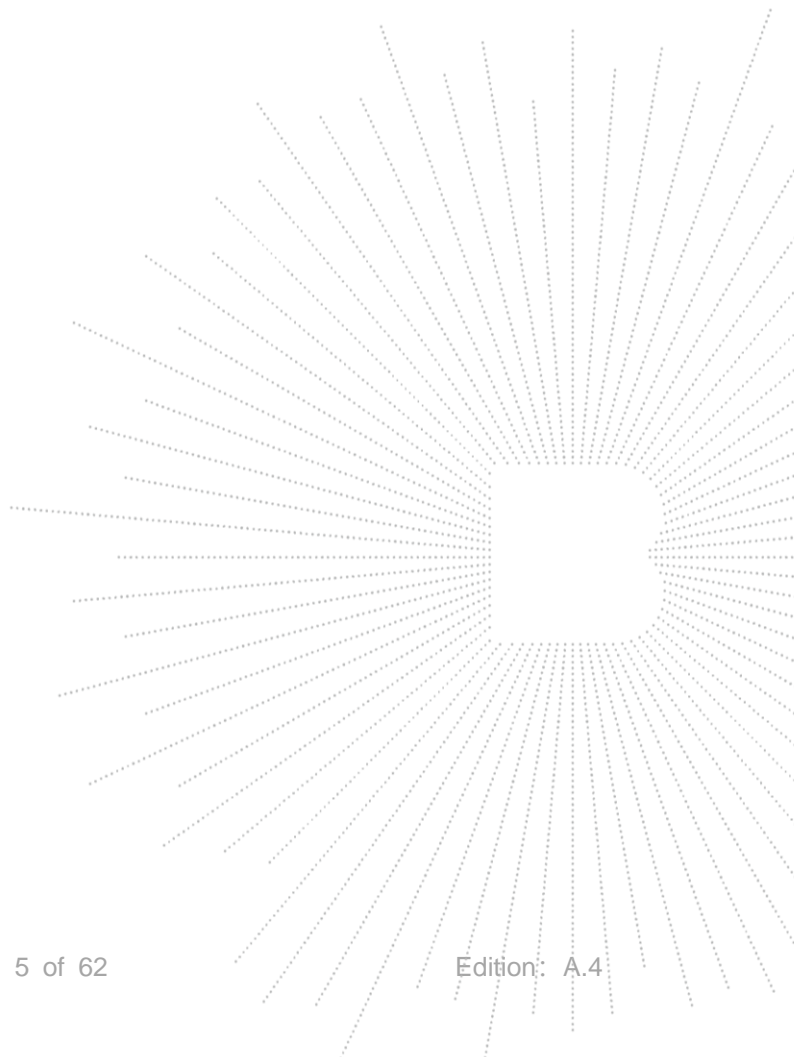

2. Test Summary

The Product has been tested according to the following specifications:

| No. | Test Parameter | Clause No | Results |
|-----|---|---|---------|
| 1 | Spurious Radiated Emissions | 15.209(a), 15.407 (b)(1) 15.407 (b)(4) 15.407 (b)(6) | PASS |
| 2 | Conducted Emission | 15.207 | N/A |
| 3 | 26 dB and 99% Emission Bandwidth | 15.407 (a)(5) 15.1049 | PASS |
| 4 | Minimum 6 dB bandwidth | 15.407(e) | PASS |
| 5 | Maximum Conducted Output Power | 15.407 (a)(1) 15.407 (a)(3) | PASS |
| 6 | Band Edge | 2.1051, 15.407(b)(1) 15.407(b)(4) | PASS |
| 7 | Power Spectral Density | 15.407 (a)(1) 15.407 (a)(3) | PASS |
| 8 | Spurious Emissions at Antenna Terminals | 2.1051, 15.407(b) | PASS |
| 8 | Antenna Requirement | 15.203 | PASS |

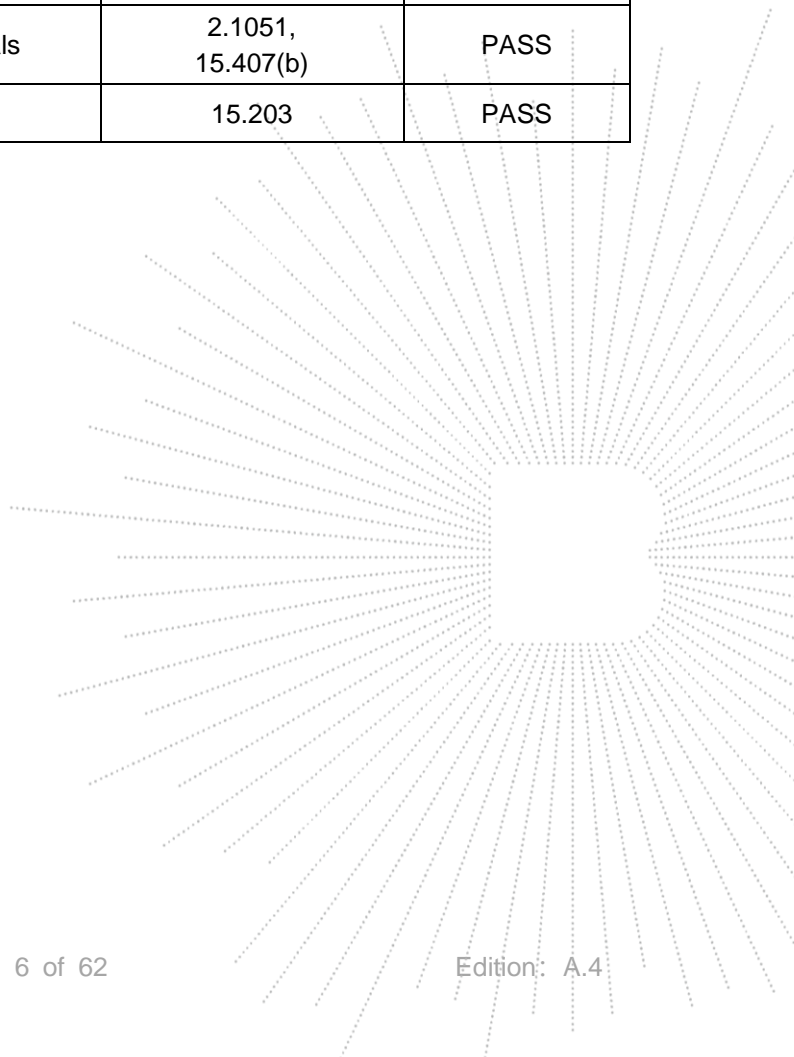

3. Measurement Uncertainty

Where relevant, the following measurement uncertainty levels have been estimated for tests performed on the Product as specified in CISPR 16-4-2. This uncertainty represents an expanded uncertainty expressed at approximately the 95% confidence level using a coverage factor of k=2.

| No. | Item | Uncertainty |
|-----|--|-------------|
| 1 | 3m chamber Radiated spurious emission(30MHz-1GHz) | U=4.3dB |
| 2 | 3m chamber Radiated spurious emission(9KHz-30MHz) | U=3.7dB |
| 3 | 3m chamber Radiated spurious emission(1GHz-18GHz) | U=4.5dB |
| 4 | 3m chamber Radiated spurious emission(18GHz-40GHz) | U=3.34dB |
| 5 | Conducted Emission (150kHz-30MHz) | U=3.20dB |
| 6 | Conducted Adjacent channel power | U=1.38dB |
| 7 | Conducted output power uncertainty Above 1G | U=1.576dB |
| 8 | Conducted output power uncertainty below 1G | U=1.28dB |
| 9 | humidity uncertainty | U=5.3% |
| 10 | Temperature uncertainty | U=0.59°C |

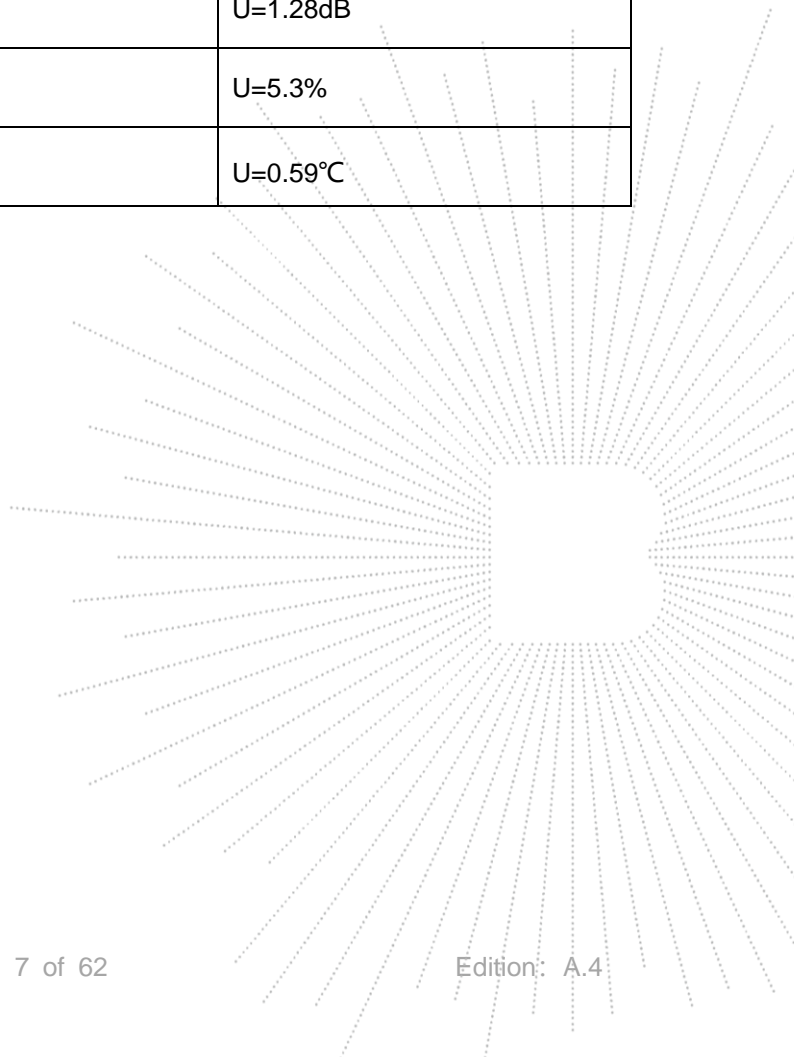

4. Product Information And Test Setup

4.1 Product Information

| | |
|---------------------------------|---|
| Model/Type Ref.: | ROCK Pi 4 MODEL B+ ROCK Pi 4 MODEL A, ROCK Pi 4 MODEL A+, ROCK Pi 4 MODEL B |
| Model differences: | All the model are the same circuit and RF module, except model names. |
| Hardware Version: | N/A |
| Software Version: | N/A |
| IEEE 802.11 WLAN Mode Supported | 802.11a/n/ac(20MHz channel bandwidth) 802.11n/ac(40MHz channel bandwidth) 802.11ac(80MHz channel bandwidth) |
| Operation Frequency: | 5180-5240MHz for 802.11a/n(HT20)/ac20; 5190-5230MHz for 802.11n(HT40)/ac40; 5210MHz for 802.11 ac80; |
| Data Rate | 802.11a: 6,9,12,18,24,36,48,54Mbps; 802.11n(HT20/HT40):MCS0-MCS15; 802.11ac(VHT20): NSS1, MCS0-MCS8 802.11ac(VHT40/VHT80):NSS1, MCS0-MCS9 |
| Type of Modulation: | OFDM with BPSK/QPSK/16QAM/64QAM/256QAM for 802.11a/n/ac; |
| Number Of Channel | 4 channels for 802.11a/n20 in the 5180-5240MHz band ; 2 channels for 802.11 n40 in the 5190-5230MHz band ; 1 channels for 802.11 ac80 in the 5210MHz band ; |
| Antenna installation: | Chip antenna |
| Antenna Gain: | 2dBi |
| Ratings: | DC 9V/12V/15V/20V |

4.2 Test Setup Configuration

See test photographs attached in *EUT TEST SETUP PHOTOGRAPHS* for the actual connections between Product and support equipment.

Conducted Emission:

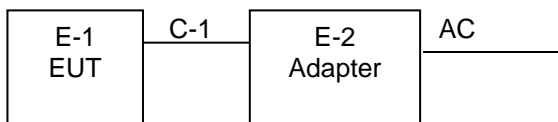

Radiated Spurious Emission

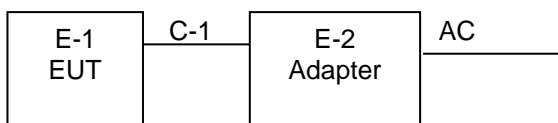

4.3 Support Equipment

| No. | Device Type | Brand | Model | Series No. | Note |
|-----|-------------|-------|--------------------|------------|-----------|
| E-1 | ROCK Pi 4 | N/A | ROCK Pi 4 MODEL B+ | N/A | EUT |
| E-2 | Adapter | N/A | BCTC001 | N/A | Auxiliary |

| Item | Shielded Type | Ferrite Core | Length | Note |
|------|---------------|--------------|--------|---------------------|
| C-1 | NO | NO | 0.5M | DC cable unshielded |

Notes:

1. All the equipment/cables were placed in the worst-case configuration to maximize the emission during the test.
2. Grounding was established in accordance with the manufacturer's requirements and conditions for the intended use.

4.4 Channel List

| 802.11a/n/ac(20MHz) Carrier Frequency Channel | | | | | | | |
|--|-----------------|---------|-----------------|---------|-----------------|---------|-----------------|
| Channel | Frequency (MHz) | Channel | Frequency (MHz) | Channel | Frequency (MHz) | Channel | Frequency (MHz) |
| 36 | 5180 | 44 | 5220 | - | - | - | - |
| 40 | 5200 | 48 | 5240 | - | - | - | - |

| 802.11n /ac(40MHz) Carrier Frequency Channel | | | | | | | |
|--|-----------------|---------|-----------------|---------|-----------------|---------|-----------------|
| Channel | Frequency (MHz) | Channel | Frequency (MHz) | Channel | Frequency (MHz) | Channel | Frequency (MHz) |
| 38 | 5190 | - | - | - | - | - | - |
| 46 | 5230 | - | - | - | - | - | - |

| 802.11ac (80MHz) Carrier Frequency Channel | |
|--|-----------------|
| Channel | Frequency (MHz) |
| 42 | 5210 |

4.5 Test Mode

To investigate the maximum EMI emission characteristics generates from EUT, the test system was pre-scanning tested base on the consideration of following EUT operation mode or test configuration mode which possible have effect on EMI emission level. Each of these EUT operation mode(s) or test configuration mode(s) mentioned above was evaluated respectively.

| Pretest Mode | Description |
|--------------|--------------------------------------|
| Mode 1 | 802.11a / n/ ac 20 CH36/ CH40/ CH 48 |
| Mode 2 | 802.11n/ ac40 CH38/ CH 46 |
| Mode 3 | 802.11 ac80 CH 42 |
| Mode 4 | Link Mode |

| For Radiated Emission | |
|-----------------------|--------------------------------------|
| Final Test Mode | Description |
| Mode 1 | 802.11a / n/ ac 20 CH36/ CH40/ CH 48 |
| Mode 2 | 802.11n/ ac40 CH38/ CH 46 |
| Mode 3 | 802.11 ac80 CH 42 |

Note:

(1) The measurements are performed at all Bit Rate of Transmitter, the worst data was reported.

4.6 Table Of Parameters Of Text Software Setting

During testing channel & power controlling software provided by the customer was used to control the operating channel as well as the output power level. The RF output power selection is for the setting of RF output power expected by the customer and is going to be fixed on the firmware of the final end product power parameters

| Test software Version | CMD | | |
|-----------------------|-----|-----|-----|
| Parameters | DEF | DEF | DEF |

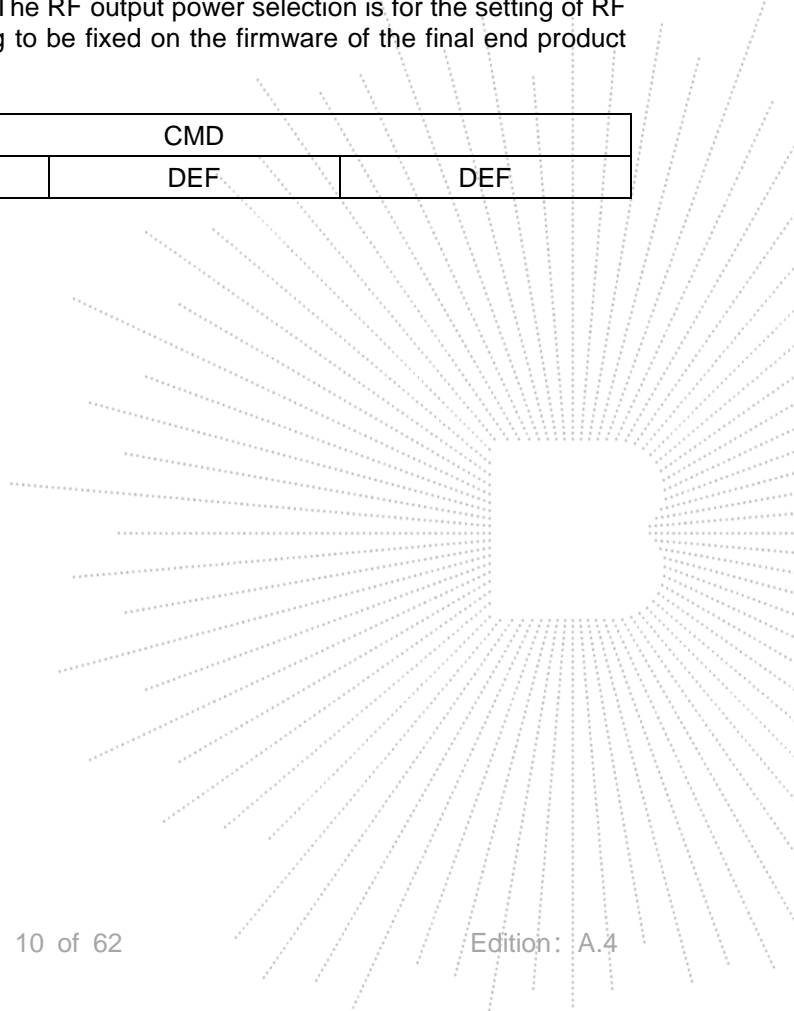

5. Test Facility And Test Instrument Used

5.1 Test Facility

All measurement facilities used to collect the measurement data are located at Shenzhen BCTC Testing Co., Ltd. Address:1-2/F., Building B, Pengzhou Industrial Park, No.158, Fuyuan 1st Road, Tangwei, Fuhai Subdistrict, Bao'an District, Shenzhen, Guangdong, China. The site and apparatus are constructed in conformance with the requirements of ANSI C63.4 and CISPR 16-1-1 other equivalent standards.

FCC Test Firm Registration Number: 712850

IC Registered No.: 23583

5.2 Test Instrument Used

| RF conducted test | | | | | |
|-------------------------------|--------------|---------|------------|--------------|--------------|
| Equipment | Manufacturer | Model# | Serial# | Last Cal. | Next Cal. |
| Power Metter | Keysight | E4419B | \ | May 28, 2021 | May 27, 2022 |
| Power Sensor (AV) | Keysight | E9 300A | \ | May 28, 2021 | May 27, 2022 |
| Signal Analyzer 20kHz-26.5GHz | KEYSIGHT | N9020A | MY49100060 | May 28, 2021 | May 27, 2022 |
| Spectrum Analyzer 9kHz-40GHz | R&S | FSP40 | 100363 | May 28, 2021 | May 27, 2022 |

| Radiated emissions Test (966 chamber) | | | | | |
|---------------------------------------|--------------|----------------------|-------------------|---------------|---------------|
| Equipment | Manufacturer | Model# | Serial# | Last Cal. | Next Cal. |
| 966 chamber | ChengYu | 966 Room | 966 | Jun. 06. 2020 | Jun. 05, 2023 |
| Receiver | R&S | ESR3 | 102075 | May 28, 2021 | May 27, 2022 |
| Receiver | R&S | ESRP | 101154 | May 28, 2021 | May 27, 2022 |
| Amplifier | SKET | LAPA_01G18 G-45dB | \ | May 28, 2021 | May 27, 2022 |
| Amplifier | Schwarzbeck | BBV9744 | 9744-0037 | May 28, 2021 | May 27, 2022 |
| TRILOG Broadband Antenna | schwarzbeck | VULB 9163 | VULB9163-9 42 | Jun. 01, 2021 | May 31, 2022 |
| Horn Antenna | SCHWARZBECK | BBHA9120D | 1541 | Jun. 02, 2021 | Jun. 01, 2022 |
| Horn Antenna (18GHz-40GHz) | SCHWARZBECK | BBHA9170 | 822 | May 28, 2021 | May 27, 2022 |
| Amplifier (18GHz-40GHz) | MITEQ | TTA1840-35- HG | 2034381 | May 28, 2021 | May 27, 2022 |
| Loop Antenna (9kHz-30MHz) | SCHWARZBECK | FMZB1519B | 014 | Jun. 02, 2021 | Jun. 01, 2022 |
| RF cables1 (9kHz-30MHz) | Huber+Suhnar | 9kHz-30MHz | B1702988-00 08 | May 28, 2021 | May 27, 2022 |
| RF cables2 (30MHz-1GHz) | Huber+Suhnar | 30MHz-1GHz | 1486150 | May 28, 2021 | May 27, 2022 |
| RF cables3 (1GHz-40GHz) | Huber+Suhnar | 1GHz-40GHz | 1607106 | May 28, 2021 | May 27, 2022 |
| Power Metter | Keysight | E4419B | \ | May 28, 2021 | May 27, 2022 |
| Power Sensor (AV) | Keysight | E9 300A | \ | May 28, 2021 | May 27, 2022 |
| Signal Analyzer 20kHz-26.5GHz | KEYSIGHT | N9020A | MY49100060 | May 28, 2021 | May 27, 2022 |
| Spectrum Analyzer 9kHz-40GHz | Agilent | FSP40 | 100363 | May 28, 2021 | May 27, 2022 |
| Software | Frad | EZ-EMC | FA-03A2 RE | \ | \ |

6. Conducted Emissions

6.1 Block Diagram Of Test Setup

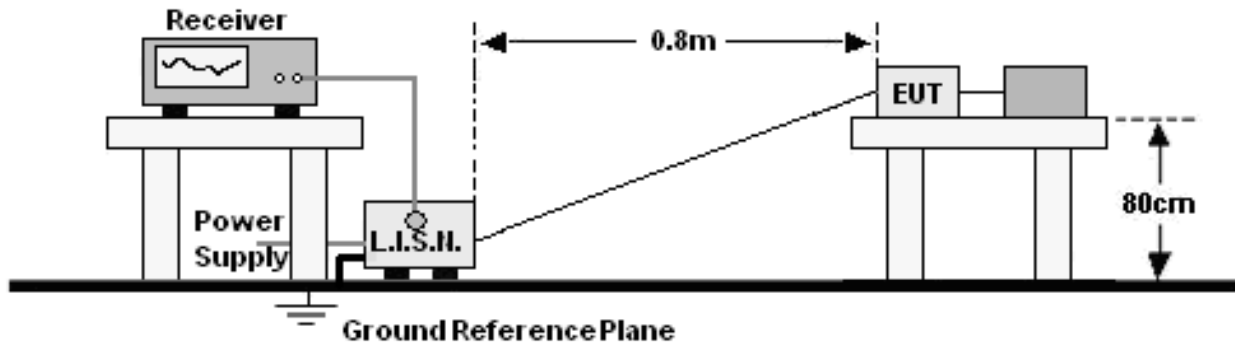

6.2 Limit

| FREQUENCY (MHz) | Limit (dBuV) | |
|-----------------|--------------|-----------|
| | Quas-peak | Average |
| 0.15 -0.5 | 66 - 56 * | 56 - 46 * |
| 0.50 -5.0 | 56.00 | 46.00 |
| 5.0 -30.0 | 60.00 | 50.00 |

Notes:

- *Decreasing linearly with logarithm of frequency.
- The lower limit shall apply at the transition frequencies.

6.3 Test Procedure

| Receiver Parameters | Setting |
|---------------------|----------|
| Attenuation | 10 dB |
| Start Frequency | 0.15 MHz |
| Stop Frequency | 30 MHz |
| IF Bandwidth | 9 kHz |

a. The Product was placed on a nonconductive table 0.8 m above the horizontal ground reference plane, and 0.4 m from the vertical ground reference plane, and connected to the main through Line Impedance Stability Network (L.I.S.N).

b. The RBW of the receiver was set at 9 kHz in 150 kHz ~ 30MHz with Peak and AVG detector in Max Hold mode. Run the receiver's pre-scan to record the maximum disturbance generated from Product in all power lines in the full band.

c. For each frequency whose maximum record was higher or close to limit, measure its QP and AVG values and record.

6.4 EUT Operating Conditions

The EUT was configured for testing in a typical fashion (as a customer would normally use it). The EUT has been programmed to continuously transmit during test. This operating condition was tested and used to collect the included data.

6.5 Test Result

| | | | |
|----------------|-------------|--------------------|--------|
| Temperature: | 26 °C | Relative Humidity: | 54% |
| Pressure: | 101kPa | Phase : | Line |
| Test Voltage : | AC120V/60Hz | Test Mode: | Mode 4 |

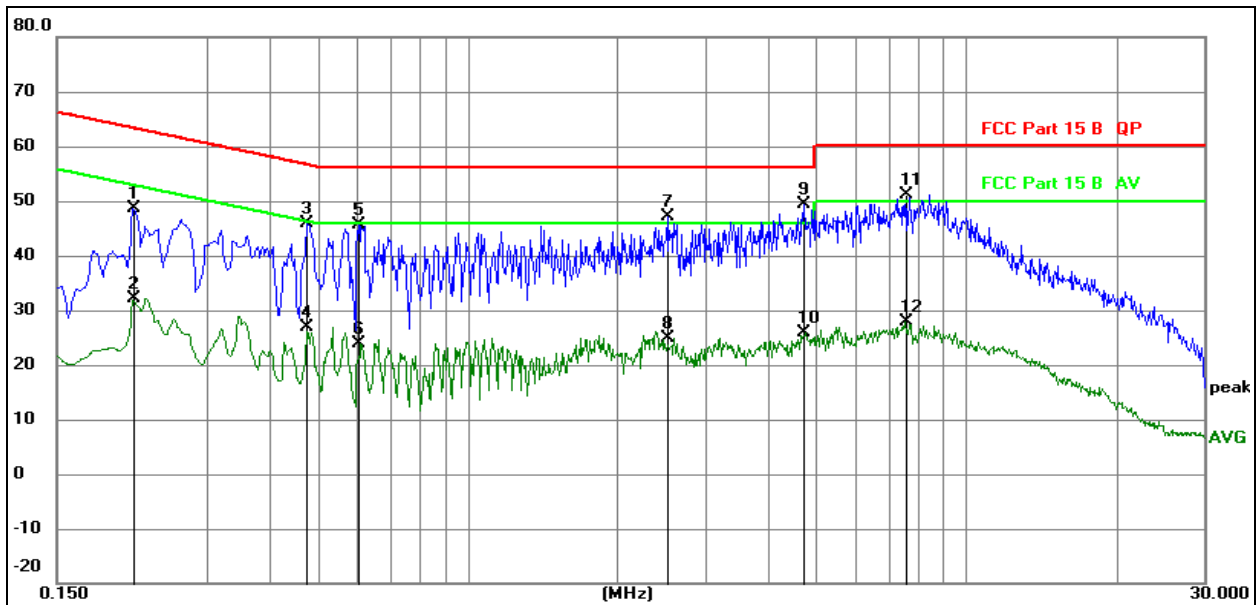

Remark:

1. All readings are Quasi-Peak and Average values.
2. Factor = Insertion Loss + Cable Loss.

| No. | Mk. | Freq. MHz | Reading Level | Correct Factor dB | Measure- ment dBuV | Limit dBuV | Over dB | Detector |
|-----|-----|--------------|------------------|-------------------------|--------------------------|---------------|------------|----------|
| 1 | | 0.2128 | 28.92 | 19.61 | 48.53 | 63.10 | -14.57 | QP |
| 2 | | 0.2128 | 12.63 | 19.61 | 32.24 | 53.10 | -20.86 | AVG |
| 3 | | 0.4761 | 26.34 | 19.62 | 45.96 | 56.41 | -10.45 | QP |
| 4 | | 0.4761 | 7.23 | 19.62 | 26.85 | 46.41 | -19.56 | AVG |
| 5 | | 0.6043 | 25.92 | 19.62 | 45.54 | 56.00 | -10.46 | QP |
| 6 | | 0.6043 | 4.17 | 19.62 | 23.79 | 46.00 | -22.21 | AVG |
| 7 | | 2.5133 | 27.43 | 19.64 | 47.07 | 56.00 | -8.93 | QP |
| 8 | | 2.5133 | 5.18 | 19.64 | 24.82 | 46.00 | -21.18 | AVG |
| 9 | * | 4.7213 | 29.60 | 19.70 | 49.30 | 56.00 | -6.70 | QP |
| 10 | | 4.7213 | 6.24 | 19.70 | 25.94 | 46.00 | -20.06 | AVG |
| 11 | | 7.5258 | 31.30 | 19.75 | 51.05 | 60.00 | -8.95 | QP |
| 12 | | 7.5258 | 8.01 | 19.75 | 27.76 | 50.00 | -22.24 | AVG |

| | | | |
|----------------|-------------|--------------------|---------|
| Temperature: | 26 °C | Relative Humidity: | 54% |
| Pressure: | 101kPa | Phase : | Neutral |
| Test Voltage : | AC120V/60Hz | Test Mode: | Mode 4 |

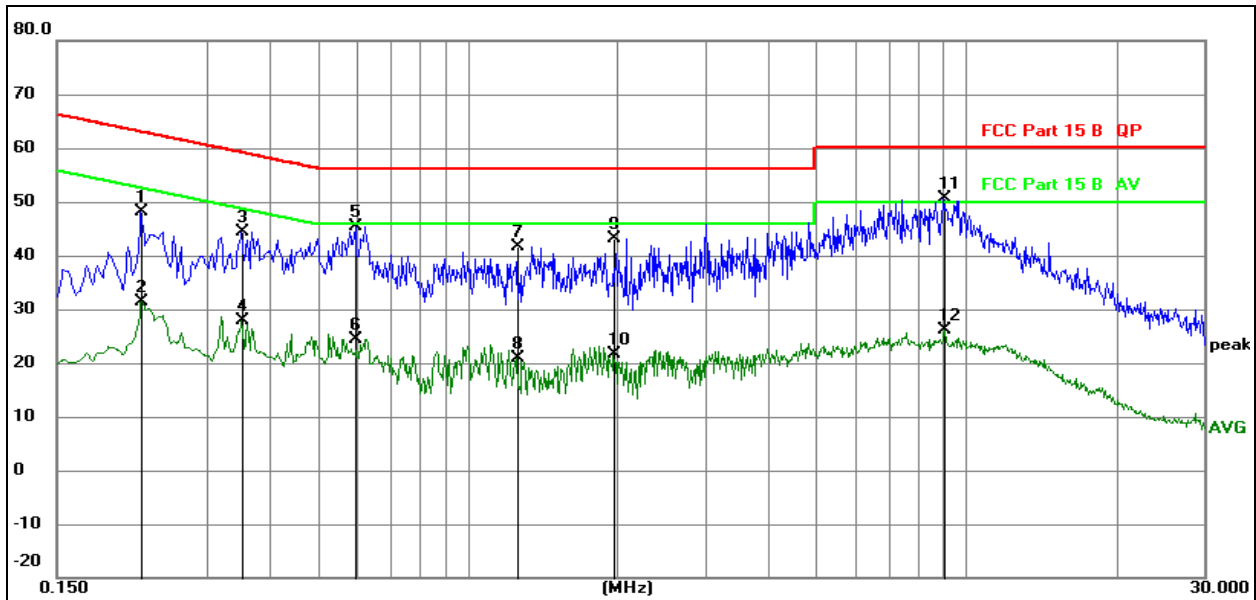
Remark:

1. All readings are Quasi-Peak and Average values.
2. Factor = Insertion Loss + Cable Loss.

| No. | Mk. | Freq. MHz | Reading Level | Correct Factor dB | Measure- ment dBuV | Limit dBuV | Over dB | Detector |
|-----|-----|--------------|------------------|-------------------------|--------------------------|---------------|------------|----------|
| 1 | | 0.2220 | 28.53 | 19.61 | 48.14 | 62.74 | -14.60 | QP |
| 2 | | 0.2220 | 11.78 | 19.61 | 31.39 | 52.74 | -21.35 | AVG |
| 3 | | 0.3525 | 24.80 | 19.62 | 44.42 | 58.90 | -14.48 | QP |
| 4 | | 0.3525 | 8.35 | 19.62 | 27.97 | 48.90 | -20.93 | AVG |
| 5 | | 0.5955 | 25.65 | 19.62 | 45.27 | 56.00 | -10.73 | QP |
| 6 | | 0.5955 | 4.77 | 19.62 | 24.39 | 46.00 | -21.61 | AVG |
| 7 | | 1.2615 | 21.97 | 19.63 | 41.60 | 56.00 | -14.40 | QP |
| 8 | | 1.2615 | 1.34 | 19.63 | 20.97 | 46.00 | -25.03 | AVG |
| 9 | | 1.9680 | 23.45 | 19.63 | 43.08 | 56.00 | -12.92 | QP |
| 10 | | 1.9680 | 2.05 | 19.63 | 21.68 | 46.00 | -24.32 | AVG |
| 11 | * | 9.0510 | 30.85 | 19.78 | 50.63 | 60.00 | -9.37 | QP |
| 12 | | 9.0510 | 6.38 | 19.78 | 26.16 | 50.00 | -23.84 | AVG |

7. Radiated Emissions

7.1 Block Diagram Of Test Setup

(A) Radiated Emission Test-Up Frequency Below 30MHz

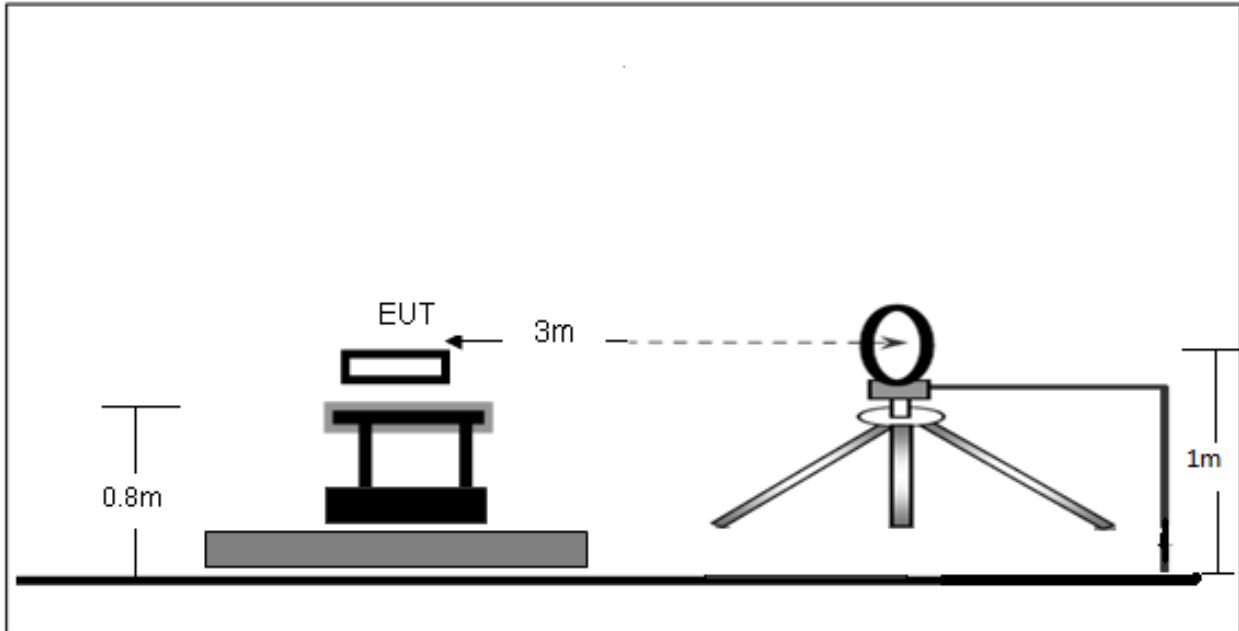

(B) Radiated Emission Test-Up Frequency 30MHz~1GHz

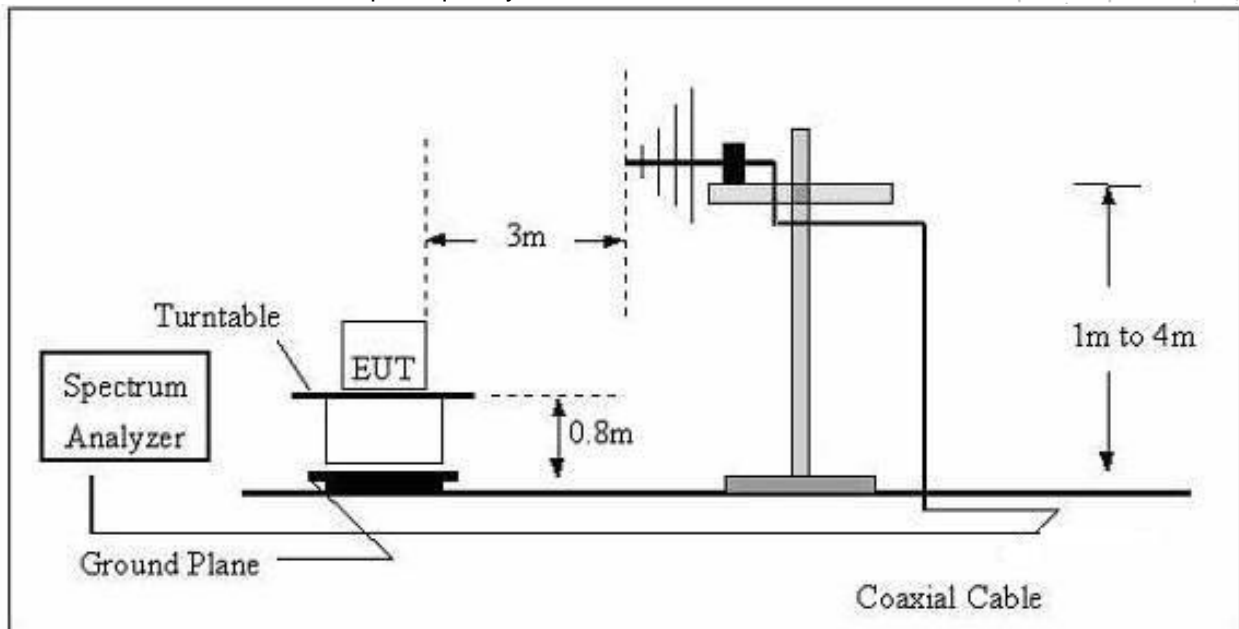

(C) Radiated Emission Test-Up Frequency Above 1GHz

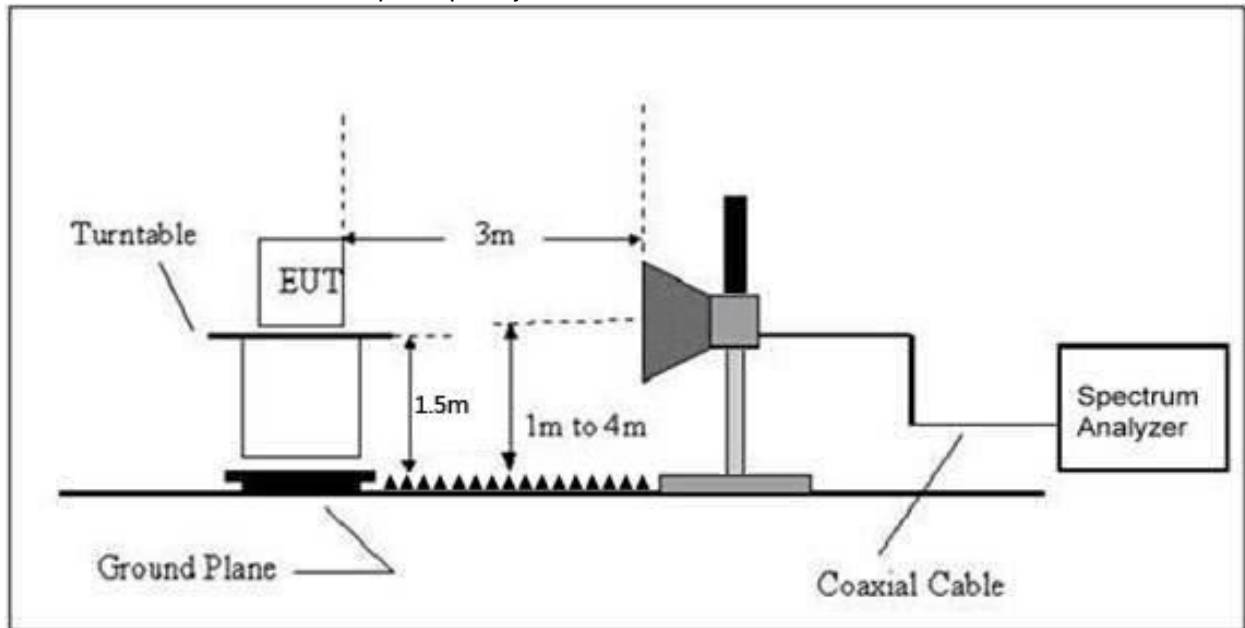

7.2 Limit

20dBc in any 100 kHz bandwidth outside the operating frequency band. In case the emission fall within the restricted band specified on 15.205(a), then the 15.209(a) limit in the table below has to be followed.

| Frequency (MHz) | Field Strength uV/m | Distance (m) | Field Strength Limit at 3m Distance | |
|--------------------|------------------------|-----------------|-------------------------------------|--------------------------------------|
| | | | uV/m | dBuV/m |
| 0.009 ~ 0.490 | 2400/F(kHz) | 300 | 10000 * 2400/F(kHz) | 20log ^{(2400/F(kHz))} + 80 |
| 0.490 ~ 1.705 | 24000/F(kHz) | 30 | 100 * 24000/F(kHz) | 20log ^{(24000/F(kHz))} + 40 |
| 1.705 ~ 30 | 30 | 30 | 100 * 30 | 20log ⁽³⁰⁾ + 40 |
| 30 ~ 88 | 100 | 3 | 100 | 20log ⁽¹⁰⁰⁾ |
| 88 ~ 216 | 150 | 3 | 150 | 20log ⁽¹⁵⁰⁾ |
| 216 ~ 960 | 200 | 3 | 200 | 20log ⁽²⁰⁰⁾ |
| Above 960 | 500 | 3 | 500 | 20log ⁽⁵⁰⁰⁾ |

LIMITS OF RADIATED EMISSION MEASUREMENT (Above 1000MHz)

| FREQUENCY (MHz) | Limit (dBuV/m) (at 3M) | |
|--------------------|------------------------|---------|
| | PEAK | AVERAGE |
| Above 1000 | 74 | 54 |

Notes:

- (1) The limit for radiated test was performed according to FCC PART 15C.
- (2) The tighter limit applies at the band edges.
- (3) Emission level (dBuV/m) = 20log Emission level (uV/m).

7.3 Test Procedure

The test site semi-anechoic chamber has met the requirement of NSA tolerance 4 dB according to the standards: ANSI C63.10-2013. The test distance is 3m. The setup is according to the requirements in Section 13.1.4.1 of ANSI C63.10-2013 and CAN/CSA-CEI/IEC CISPR 22.

This test is required for any spurious emission that falls in a Restricted Band, as defined in Section 15.205.

It must be performed with the highest gain of each type of antenna proposed for use with the EUT.

Use the following spectrum analyzer settings:

| Spectrum Parameter | Setting |
|---------------------------------------|--|
| Attenuation | Auto |
| Start Frequency | 1000 MHz |
| Stop Frequency | 10th carrier harmonic |
| RB / VB (emission in restricted band) | 1 MHz / 1 MHz for Peak, 1 MHz / 10Hz for Average |

| Receiver Parameter | Setting |
|------------------------|----------------------------------|
| Attenuation | Auto |
| Start ~ Stop Frequency | 9kHz~150kHz / RB 200Hz for QP |
| Start ~ Stop Frequency | 150kHz~30MHz / RB 9kHz for QP |
| Start ~ Stop Frequency | 30MHz~1000MHz / RB 120kHz for QP |

- The measuring distance of at 3 m shall be used for measurements at frequency up to 1GHz. For frequencies above 1GHz, any suitable measuring distance may be used.
- The EUT was placed on the top of a rotating table 0.8 m for below 1GHz and 1.5m for above 1GHz the ground at a 3 meter. The table was rotated 360 degrees to determine the position of the highest radiation.
- The height of the equipment or of the substitution antenna shall be 0.8 m for below 1GHz and 1.5m for above 1GHz; the height of the test antenna shall vary between 1 m to 4 m. Both horizontal and vertical polarizations of the antenna are set to make the measurement.
- The initial step in collecting conducted emission data is a spectrum analyzer peak detector mode pre-scanning the measurement frequency range. Significant peaks are then marked and then Quasi Peak detector mode re-measured.
- If the Peak Mode measured value compliance with and lower than Quasi Peak Mode Limit, the EUT shall be deemed to meet QP Limits and then no additional QP Mode measurement performed.
- For the actual test configuration, please refer to the related Item –EUT Test Photos.

Note:

Both horizontal and vertical antenna polarities were tested and performed pretest to three orthogonal axis. The worst case emissions were reported

During the radiated emission test, the Spectrum Analyzer was set with the following configurations:

| Frequency Band (MHz) | Function | Resolution bandwidth | Video Bandwidth |
|----------------------|----------|----------------------|-----------------|
| 30 to 1000 | QP | 120 kHz | 300 kHz |
| Above 1000 | Peak | 1 MHz | 1 MHz |
| | Average | 1 MHz | 10 Hz |

Note: for the frequency ranges below 30 MHz, a narrower RBW is used for these ranges but the measured value should add a RBW correction factor (RBWCF) where $RBWCF [dB] = 10 \cdot \lg(100 [kHz] / \text{narrower RBW} [kHz])$. , the narrower RBW is 1 kHz and RBWCF is 20 dB for the frequency 9 kHz to 150 kHz, and the narrower RBW is 10 kHz and RBWCF is 10 dB for the frequency 150 kHz to 30 MHz.

7.4 EUT Operating Conditions

The EUT was configured for testing in a typical fashion (as a customer would normally use it). The EUT has been programmed to continuously transmit during test. This operating condition was tested and used to collect the included data.

7.5 Test Result

Below 30MHz

| | | | |
|--------------|---------|--------------------|-------------|
| Temperature: | 26°C | Relative Humidity: | 24% |
| Pressure: | 101 kPa | Test Voltage : | AC120V/60Hz |
| Test Mode: | Mode 4 | Polarization : | -- |

| Freq. (MHz) | Reading (dBuV/m) | Limit (dBuV/m) | Margin (dB) | State P/F |
|----------------|---------------------|-------------------|----------------|--------------|
| -- | -- | -- | -- | PASS |
| -- | -- | -- | -- | PASS |

Note:

The amplitude of spurious emissions which are attenuated by more than 20dB below the permissible value has no need to be reported.

Distance extrapolation factor = $40 \log(\text{specific distance/test distance})(\text{dB})$;

Limit line = specific limits(dBuv) + distance extrapolation factor.

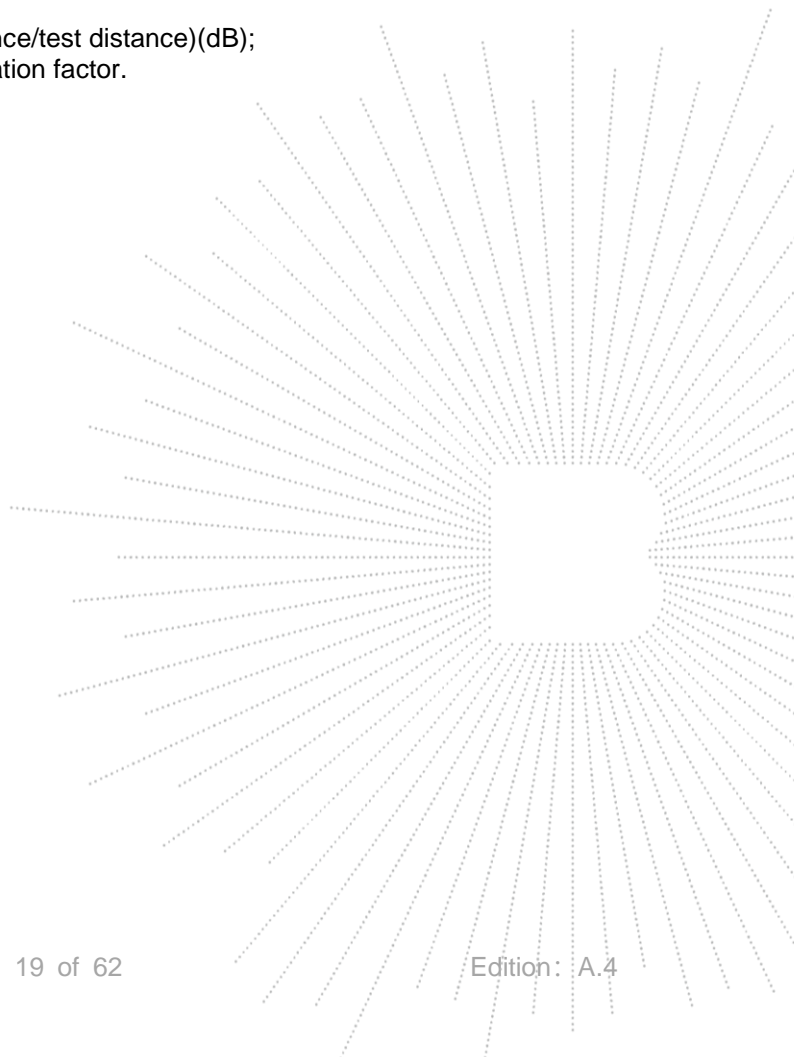

Between 30MHz – 1GHz

| | | | |
|--------------|---------|--------------------|-------------|
| Temperature: | 26°C | Relative Humidity: | 54% |
| Pressure: | 101 kPa | Test Voltage : | AC120V/60Hz |
| Test Mode: | Mode 4 | Polarization : | Horizontal |

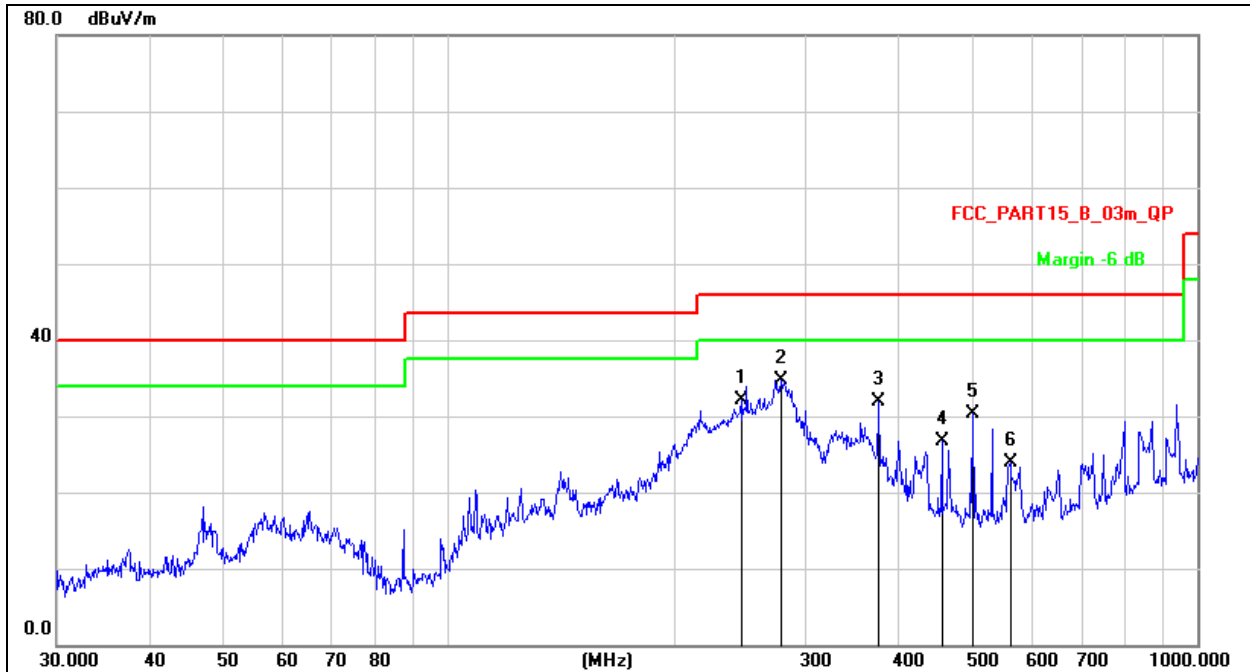

Remark:
Factor = Antenna Factor + Cable Loss – Pre-amplifier.

| No. | Mk. | Freq. | Reading Level | Correct Factor | Measurement | Limit | Over | |
|-----|-----|----------|---------------|----------------|-------------|-------|--------|----------|
| | | MHz | dBuV | dB | dBuV/m | dB/m | dB | Detector |
| 1 | | 245.9509 | 47.26 | -15.24 | 32.02 | 46.00 | -13.98 | QP |
| 2 | * | 278.0668 | 48.90 | -14.28 | 34.62 | 46.00 | -11.38 | QP |
| 3 | | 375.9385 | 43.55 | -11.64 | 31.91 | 46.00 | -14.09 | QP |
| 4 | | 455.9058 | 36.46 | -9.85 | 26.61 | 46.00 | -19.39 | QP |
| 5 | | 501.1790 | 39.19 | -8.91 | 30.28 | 46.00 | -15.72 | QP |
| 6 | | 562.6624 | 31.20 | -7.39 | 23.81 | 46.00 | -22.19 | QP |

| | | | |
|--------------|---------|--------------------|-------------|
| Temperature: | 26°C | Relative Humidity: | 54% |
| Pressure: | 101 kpa | Test Voltage : | AC120V/60Hz |
| Test Mode: | Mode 4 | Polarization : | Vertical |

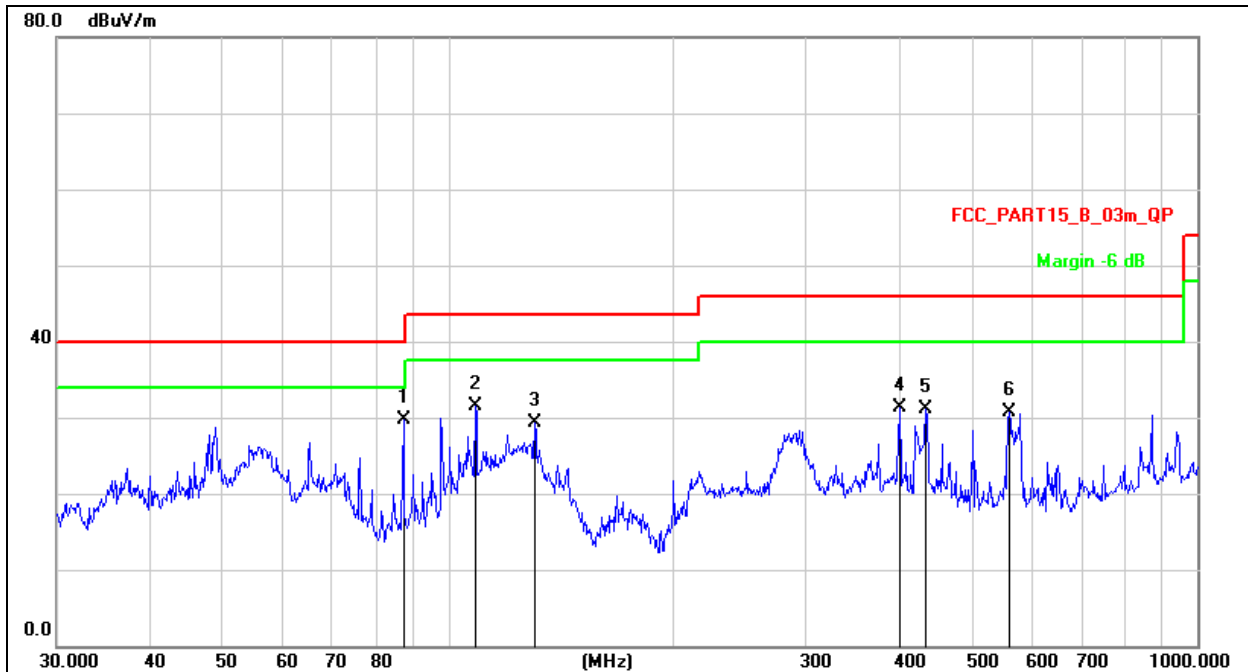

Remark:

Factor = Antenna Factor + Cable Loss – Pre-amplifier.

| No. | Mk. | Freq. | Reading Level | Correct Factor | Measurement | Limit | Over | |
|-----|-----|----------|---------------|----------------|-------------|-------|--------|----------|
| | | MHz | dBuV | dB | dBuV/m | dB/m | dB | Detector |
| 1 | * | 87.1117 | 48.39 | -18.77 | 29.62 | 40.00 | -10.38 | QP |
| 2 | | 108.6470 | 48.37 | -16.84 | 31.53 | 43.50 | -11.97 | QP |
| 3 | | 130.3789 | 47.46 | -18.24 | 29.22 | 43.50 | -14.28 | QP |
| 4 | | 400.4319 | 42.41 | -11.08 | 31.33 | 46.00 | -14.67 | QP |
| 5 | | 434.0651 | 41.39 | -10.33 | 31.06 | 46.00 | -14.94 | QP |
| 6 | | 560.6928 | 38.18 | -7.43 | 30.75 | 46.00 | -15.25 | QP |

Between 1GHz – 40GHz

| | |
|-------------|--------------------|
| Test Mode : | TX(5.1G) - 802.11a |
|-------------|--------------------|

| Polar (H/V) | Frequency | Meter Reading | Cable loss | Antenna Factor | Preamp Factor | Emission Level | Limits | Margin | Detector Type |
|------------------------------------|-----------|---------------|------------|----------------|---------------|----------------|----------|--------|---------------|
| | (MHz) | (dBuV) | (dB) | dB/m | (dB) | (dBuV/m) | (dBuV/m) | (dB) | |
| Low Channel (5180 MHz)-Above 1G | | | | | | | | | |
| V | 4434.169 | 63.58 | 5.94 | 35.40 | 44.00 | 60.92 | 68.20 | -7.28 | PK |
| V | 4434.169 | 43.87 | 5.94 | 35.40 | 44.00 | 41.21 | 54.00 | -12.79 | AV |
| V | 10360.080 | 62.18 | 8.46 | 39.75 | 44.50 | 65.89 | 74.00 | -8.11 | PK |
| V | 10360.080 | 43.60 | 8.46 | 39.75 | 44.50 | 47.31 | 54.00 | -6.69 | AV |
| V | 15540.142 | 62.68 | 10.12 | 38.80 | 44.10 | 67.50 | 74.00 | -6.50 | PK |
| V | 15540.142 | 43.01 | 10.12 | 38.80 | 42.70 | 49.23 | 54.00 | -4.77 | AV |
| H | 4434.009 | 61.21 | 5.94 | 35.18 | 44.00 | 58.33 | 68.20 | -9.87 | PK |
| H | 4434.009 | 43.32 | 5.94 | 35.18 | 44.00 | 40.44 | 54.00 | -13.56 | AV |
| H | 10360.087 | 50.43 | 8.46 | 38.71 | 44.50 | 53.10 | 74.00 | -20.90 | PK |
| H | 10360.087 | 40.59 | 8.46 | 38.71 | 44.50 | 43.26 | 54.00 | -10.74 | AV |
| H | 15540.148 | 50.21 | 10.12 | 38.38 | 44.10 | 54.61 | 74.00 | -19.39 | PK |
| H | 15540.148 | 42.84 | 10.12 | 38.38 | 44.10 | 47.24 | 54.00 | -6.76 | AV |
| middle Channel (5200 MHz)-Above 1G | | | | | | | | | |
| V | 4592.023 | 64.21 | 6.48 | 36.35 | 44.05 | 62.99 | 74.00 | -11.01 | PK |
| V | 4592.023 | 43.97 | 6.48 | 36.35 | 44.05 | 42.75 | 54.00 | -11.25 | AV |
| V | 10400.175 | 64.37 | 8.47 | 37.88 | 44.51 | 66.21 | 68.20 | -1.99 | PK |
| V | 10400.175 | 43.70 | 8.47 | 37.88 | 44.51 | 45.54 | 54.00 | -8.46 | AV |
| V | 15600.030 | 64.75 | 10.12 | 38.80 | 44.10 | 69.57 | 74.00 | -4.43 | PK |
| V | 15600.030 | 43.93 | 10.12 | 38.80 | 42.70 | 50.15 | 54.00 | -3.85 | AV |
| H | 4592.007 | 62.65 | 6.48 | 36.37 | 44.05 | 61.45 | 74.00 | -12.55 | PK |
| H | 4592.007 | 43.41 | 6.48 | 36.37 | 44.05 | 42.21 | 54.00 | -11.79 | AV |
| H | 10400.089 | 54.00 | 8.47 | 38.64 | 44.50 | 56.61 | 68.20 | -11.59 | PK |
| H | 10400.089 | 42.33 | 8.47 | 38.64 | 44.50 | 44.94 | 54.00 | -9.06 | AV |
| H | 15600.108 | 53.25 | 10.12 | 38.38 | 44.10 | 57.65 | 74.00 | -16.35 | PK |
| H | 15600.108 | 40.90 | 10.12 | 38.38 | 44.10 | 45.30 | 54.00 | -8.70 | AV |
| High Channel (5240 MHz)-Above 1G | | | | | | | | | |
| V | 4739.047 | 61.91 | 7.10 | 37.24 | 43.50 | 62.75 | 74.00 | -11.25 | PK |
| V | 4739.047 | 43.81 | 7.10 | 37.24 | 43.50 | 44.65 | 54.00 | -9.35 | AV |
| V | 10480.059 | 60.75 | 8.46 | 37.68 | 44.50 | 62.39 | 68.20 | -5.81 | PK |
| V | 10480.059 | 43.24 | 8.46 | 37.68 | 44.50 | 44.88 | 54.00 | -9.12 | AV |
| V | 15720.124 | 64.94 | 10.12 | 38.80 | 44.10 | 69.76 | 74.00 | -4.24 | PK |
| V | 15720.124 | 43.42 | 10.12 | 38.80 | 42.70 | 49.64 | 54.00 | -4.36 | AV |
| H | 4739.060 | 61.89 | 7.10 | 37.24 | 43.50 | 62.73 | 74.00 | -11.27 | PK |
| H | 4739.060 | 43.72 | 7.10 | 37.24 | 43.50 | 44.56 | 54.00 | -9.44 | AV |
| H | 10480.059 | 50.17 | 8.46 | 38.57 | 44.50 | 52.70 | 68.20 | -15.50 | PK |
| H | 10480.059 | 43.53 | 8.46 | 38.57 | 44.50 | 46.06 | 54.00 | -7.94 | AV |
| H | 15720.075 | 53.77 | 10.12 | 38.38 | 44.10 | 58.17 | 74.00 | -15.83 | PK |
| H | 15720.075 | 43.78 | 10.12 | 38.38 | 44.10 | 48.18 | 54.00 | -5.82 | AV |

Note: PK value is lower than the Average value limit, So average didn't record.

The 26.5-40G amplitude of spurious emissions that are attenuated by more than 20dB below the permissible value has no need to be reported.

Emission level (dBuV/m) = 20 log Emission level (uV/m).

Corrected Reading: Antenna Factor + Cable Loss + Read Level - Preamp Factor = Level.

The worst case is Antenna A.

| | |
|-------------|-------------------------|
| Test Mode : | TX(5.1G) - 802.11n-HT20 |
|-------------|-------------------------|

| Polar (H/V) | Frequency | Meter Reading | Cable loss | Antenna Factor | Preamp Factor | Emission Level | Limits | Margin | Detector Type |
|------------------------------------|-----------|---------------|------------|----------------|---------------|----------------|----------|--------|---------------|
| | (MHz) | (dBuV) | (dB) | dB/m | (dB) | (dBuV/m) | (dBuV/m) | (dB) | |
| Low Channel (5180 MHz)-Above 1G | | | | | | | | | |
| V | 4434.004 | 63.55 | 5.94 | 35.40 | 44.00 | 60.89 | 68.20 | -7.31 | PK |
| V | 4434.004 | 43.24 | 5.94 | 35.40 | 44.00 | 40.58 | 54.00 | -13.42 | AV |
| V | 10360.188 | 61.28 | 8.46 | 39.75 | 44.50 | 64.99 | 68.20 | -3.21 | PK |
| V | 10360.188 | 43.06 | 8.46 | 39.75 | 44.50 | 46.77 | 54.00 | -7.23 | AV |
| V | 15540.064 | 63.52 | 10.12 | 38.80 | 44.10 | 68.34 | 74.00 | -5.66 | PK |
| V | 15540.064 | 43.87 | 10.12 | 38.80 | 42.70 | 50.09 | 54.00 | -3.91 | AV |
| H | 4434.077 | 64.39 | 5.94 | 35.18 | 44.00 | 61.51 | 68.20 | -6.69 | PK |
| H | 4434.077 | 43.25 | 5.94 | 35.18 | 44.00 | 40.37 | 54.00 | -13.63 | AV |
| H | 10360.061 | 50.58 | 8.46 | 38.71 | 44.50 | 53.25 | 68.20 | -14.95 | PK |
| H | 10360.061 | 44.28 | 8.46 | 38.71 | 44.50 | 46.95 | 54.00 | -7.05 | AV |
| H | 15540.042 | 54.85 | 10.12 | 38.38 | 44.10 | 59.25 | 74.00 | -14.75 | PK |
| H | 15540.042 | 41.52 | 10.12 | 38.38 | 44.10 | 45.92 | 54.00 | -8.08 | AV |
| middle Channel (5200 MHz)-Above 1G | | | | | | | | | |
| V | 4592.098 | 60.30 | 6.48 | 36.35 | 44.05 | 59.08 | 74.00 | -14.92 | PK |
| V | 4592.098 | 43.79 | 6.48 | 36.35 | 44.05 | 42.57 | 54.00 | -11.43 | AV |
| V | 10400.033 | 64.40 | 8.47 | 37.88 | 44.51 | 66.24 | 68.20 | -1.96 | PK |
| V | 10400.033 | 43.09 | 8.47 | 37.88 | 44.51 | 44.93 | 54.00 | -9.07 | AV |
| V | 15600.159 | 63.62 | 10.12 | 38.80 | 44.10 | 68.44 | 74.00 | -5.56 | PK |
| V | 15600.159 | 43.47 | 10.12 | 38.80 | 42.70 | 49.69 | 54.00 | -4.31 | AV |
| H | 4592.115 | 64.70 | 6.48 | 36.37 | 44.05 | 63.50 | 74.00 | -10.50 | PK |
| H | 4592.115 | 43.44 | 6.48 | 36.37 | 44.05 | 42.24 | 54.00 | -11.76 | AV |
| H | 10400.098 | 51.19 | 8.47 | 38.64 | 44.50 | 53.80 | 68.20 | -14.40 | PK |
| H | 10400.098 | 44.42 | 8.47 | 38.64 | 44.50 | 47.03 | 54.00 | -6.97 | AV |
| H | 15600.190 | 52.27 | 10.12 | 38.38 | 44.10 | 56.67 | 74.00 | -17.33 | PK |
| H | 15600.190 | 40.06 | 10.12 | 38.38 | 44.10 | 44.46 | 54.00 | -9.54 | AV |
| High Channel (5240 MHz)-Above 1G | | | | | | | | | |
| V | 4739.131 | 64.22 | 7.10 | 37.24 | 43.50 | 65.06 | 74.00 | -8.94 | PK |
| V | 4739.131 | 43.05 | 7.10 | 37.24 | 43.50 | 43.89 | 54.00 | -10.11 | AV |
| V | 10480.030 | 63.55 | 8.46 | 37.68 | 44.50 | 65.19 | 68.20 | -3.01 | PK |
| V | 10480.030 | 43.27 | 8.46 | 37.68 | 44.50 | 44.91 | 54.00 | -9.09 | AV |
| V | 15720.142 | 62.73 | 10.12 | 38.80 | 44.10 | 67.55 | 74.00 | -6.45 | PK |
| V | 15720.142 | 43.80 | 10.12 | 38.80 | 42.70 | 50.02 | 54.00 | -3.98 | AV |
| H | 4739.166 | 62.98 | 7.10 | 37.24 | 43.50 | 63.82 | 74.00 | -10.18 | PK |
| H | 4739.166 | 43.26 | 7.10 | 37.24 | 43.50 | 44.10 | 54.00 | -9.90 | AV |
| H | 10480.142 | 54.37 | 8.46 | 38.57 | 44.50 | 56.90 | 68.20 | -11.30 | PK |
| H | 10480.142 | 43.94 | 8.46 | 38.57 | 44.50 | 46.47 | 54.00 | -7.53 | AV |
| H | 15720.013 | 51.70 | 10.12 | 38.38 | 44.10 | 56.10 | 74.00 | -17.90 | PK |
| H | 15720.013 | 44.51 | 10.12 | 38.38 | 44.10 | 48.91 | 54.00 | -5.09 | AV |

Note: PK value is lower than the Average value limit, So average didn't record.

The 26.5-40G amplitude of spurious emissions that are attenuated by more than 20dB below the permissible value has no need to be reported.

Emission level (dBuV/m) = 20 log Emission level (uV/m).

Corrected Reading: Antenna Factor + Cable Loss + Read Level - Preamp Factor = Level.

Test Mode is MIMO Mode.

| | |
|-------------|-------------------------|
| Test Mode : | TX(5.1G) - 802.11n-HT40 |
|-------------|-------------------------|

| Polar (H/V) | Frequency (MHz) | Meter Reading (dBuV) | Cable loss (dB) | Antenna Factor (dB/m) | Preamp Factor (dB) | Emission Level (dBuV/m) | Limits (dBuV/m) | Margin (dB) | Detector Type |
|------------------------------------|-----------------|----------------------|-----------------|-----------------------|--------------------|-------------------------|-----------------|-------------|---------------|
| Low Channel (5190 MHz)-Above 1G | | | | | | | | | |
| V | 4434.125 | 64.70 | 5.94 | 35.40 | 44.00 | 62.04 | 74.00 | -11.96 | PK |
| V | 4434.125 | 43.01 | 5.94 | 35.40 | 44.00 | 40.35 | 54.00 | -13.65 | AV |
| V | 10380.166 | 60.16 | 8.46 | 39.75 | 44.50 | 63.87 | 68.20 | -4.33 | PK |
| V | 10380.166 | 43.75 | 8.46 | 39.75 | 44.50 | 47.46 | 54.00 | -6.54 | AV |
| V | 15570.061 | 61.06 | 10.12 | 38.80 | 44.10 | 65.88 | 74.00 | -8.12 | PK |
| V | 15570.061 | 43.61 | 10.12 | 38.80 | 42.70 | 49.83 | 54.00 | -4.17 | AV |
| H | 4434.009 | 62.87 | 5.94 | 35.18 | 44.00 | 59.99 | 74.00 | -14.01 | PK |
| H | 4434.009 | 43.00 | 5.94 | 35.18 | 44.00 | 40.12 | 54.00 | -13.88 | AV |
| H | 10380.147 | 50.61 | 8.46 | 38.71 | 44.50 | 53.28 | 68.20 | -14.92 | PK |
| H | 10380.147 | 42.63 | 8.46 | 38.71 | 44.50 | 45.30 | 54.00 | -8.70 | AV |
| H | 15570.080 | 54.70 | 10.12 | 38.38 | 44.10 | 59.10 | 74.00 | -14.90 | PK |
| H | 15570.080 | 40.64 | 10.12 | 38.38 | 44.10 | 45.04 | 54.00 | -8.96 | AV |
| middle Channel (5230 MHz)-Above 1G | | | | | | | | | |
| V | 4739.133 | 62.91 | 6.48 | 36.35 | 44.05 | 61.69 | 74.00 | -12.31 | PK |
| V | 4739.133 | 43.65 | 6.48 | 36.35 | 44.05 | 42.43 | 54.00 | -11.57 | AV |
| V | 10460.140 | 62.66 | 8.47 | 37.88 | 44.51 | 64.50 | 68.20 | -3.70 | PK |
| V | 10460.140 | 43.15 | 8.47 | 37.88 | 44.51 | 44.99 | 54.00 | -9.01 | AV |
| V | 15690.053 | 62.65 | 10.12 | 38.80 | 44.10 | 67.47 | 74.00 | -6.53 | PK |
| V | 15690.053 | 43.56 | 10.12 | 38.80 | 42.70 | 49.78 | 54.00 | -4.22 | AV |
| H | 4739.104 | 62.21 | 6.48 | 36.37 | 44.05 | 61.01 | 74.00 | -12.99 | PK |
| H | 4739.104 | 43.16 | 6.48 | 36.37 | 44.05 | 41.96 | 54.00 | -12.04 | AV |
| H | 10460.053 | 54.08 | 8.47 | 38.64 | 44.50 | 56.69 | 68.20 | -11.51 | PK |
| H | 10460.053 | 41.44 | 8.47 | 38.64 | 44.50 | 44.05 | 54.00 | -9.95 | AV |
| H | 15690.146 | 50.43 | 10.12 | 38.38 | 44.10 | 54.83 | 74.00 | -19.17 | PK |
| H | 15690.146 | 43.60 | 10.12 | 38.38 | 44.10 | 48.00 | 54.00 | -6.00 | AV |

Note: PK value is lower than the Average value limit, So average didn't record.

The 26.5-40G amplitude of spurious emissions that are attenuated by more than 20dB below the permissible value has no need to be reported.

Emission level (dBuV/m) = 20 log Emission level (uV/m).

Corrected Reading: Antenna Factor + Cable Loss + Read Level - Preamp Factor = Level.

Test Mode is MIMO Mode.

| | |
|-------------|------------------------|
| Test Mode : | TX(5.1G) - 802.11 AC20 |
|-------------|------------------------|

| Polar (H/V) | Frequency | Meter Reading | Cable loss | Antenna Factor | Preamp Factor | Emission Level | Limits | Margin | Detector Type |
|------------------------------------|-----------|---------------|------------|----------------|---------------|----------------|----------|--------|---------------|
| | (MHz) | (dBuV) | (dB) | dB/m | (dB) | (dBuV/m) | (dBuV/m) | (dB) | |
| Low Channel (5180 MHz)-Above 1G | | | | | | | | | |
| V | 4434.075 | 60.90 | 5.94 | 35.40 | 44.00 | 58.24 | 68.20 | -9.96 | PK |
| V | 4434.075 | 43.54 | 5.94 | 35.40 | 44.00 | 40.88 | 54.00 | -13.12 | AV |
| V | 10360.141 | 63.31 | 8.46 | 39.75 | 44.50 | 67.02 | 74.00 | -6.98 | PK |
| V | 10360.141 | 43.10 | 8.46 | 39.75 | 44.50 | 46.81 | 54.00 | -7.19 | AV |
| V | 15540.032 | 63.10 | 10.12 | 38.80 | 44.10 | 67.92 | 74.00 | -6.08 | PK |
| V | 15540.032 | 43.11 | 10.12 | 38.80 | 42.70 | 49.33 | 54.00 | -4.67 | AV |
| H | 4434.130 | 60.01 | 5.94 | 35.18 | 44.00 | 57.13 | 68.20 | -11.07 | PK |
| H | 4434.130 | 43.77 | 5.94 | 35.18 | 44.00 | 40.89 | 54.00 | -13.11 | AV |
| H | 10360.110 | 52.29 | 8.46 | 38.71 | 44.50 | 54.96 | 74.00 | -19.04 | PK |
| H | 10360.110 | 44.84 | 8.46 | 38.71 | 44.50 | 47.51 | 54.00 | -6.49 | AV |
| H | 15540.173 | 53.88 | 10.12 | 38.38 | 44.10 | 58.28 | 74.00 | -15.72 | PK |
| H | 15540.173 | 44.83 | 10.12 | 38.38 | 44.10 | 49.23 | 54.00 | -4.77 | AV |
| middle Channel (5200 MHz)-Above 1G | | | | | | | | | |
| V | 4592.104 | 62.18 | 6.48 | 36.35 | 44.05 | 60.96 | 74.00 | -13.04 | PK |
| V | 4592.104 | 43.34 | 6.48 | 36.35 | 44.05 | 42.12 | 54.00 | -11.88 | AV |
| V | 10400.076 | 62.24 | 8.47 | 37.88 | 44.51 | 64.08 | 68.20 | -4.12 | PK |
| V | 10400.076 | 43.98 | 8.47 | 37.88 | 44.51 | 45.82 | 54.00 | -8.18 | AV |
| V | 15600.161 | 64.35 | 10.12 | 38.80 | 44.10 | 69.17 | 74.00 | -4.83 | PK |
| V | 15600.161 | 43.09 | 10.12 | 38.80 | 42.70 | 49.31 | 54.00 | -4.69 | AV |
| H | 4592.089 | 60.08 | 6.48 | 36.37 | 44.05 | 58.88 | 74.00 | -15.12 | PK |
| H | 4592.089 | 43.61 | 6.48 | 36.37 | 44.05 | 42.41 | 54.00 | -11.59 | AV |
| H | 10400.078 | 50.40 | 8.47 | 38.64 | 44.50 | 53.01 | 68.20 | -15.19 | PK |
| H | 10400.078 | 44.05 | 8.47 | 38.64 | 44.50 | 46.66 | 54.00 | -7.34 | AV |
| H | 15600.176 | 50.42 | 10.12 | 38.38 | 44.10 | 54.82 | 74.00 | -19.18 | PK |
| H | 15600.176 | 44.17 | 10.12 | 38.38 | 44.10 | 48.57 | 54.00 | -5.43 | AV |
| High Channel (5240 MHz)-Above 1G | | | | | | | | | |
| V | 4739.015 | 64.37 | 7.10 | 37.24 | 43.50 | 65.21 | 74.00 | -8.79 | PK |
| V | 4739.015 | 43.75 | 7.10 | 37.24 | 43.50 | 44.59 | 54.00 | -9.41 | AV |
| V | 10480.067 | 60.90 | 8.46 | 37.68 | 44.50 | 62.54 | 68.20 | -5.66 | PK |
| V | 10480.067 | 43.82 | 8.46 | 37.68 | 44.50 | 45.46 | 54.00 | -8.54 | AV |
| V | 15720.151 | 61.69 | 10.12 | 38.80 | 44.10 | 66.51 | 74.00 | -7.49 | PK |
| V | 15720.151 | 43.71 | 10.12 | 38.80 | 42.70 | 49.93 | 54.00 | -4.07 | AV |
| H | 4739.092 | 60.17 | 7.10 | 37.24 | 43.50 | 61.01 | 74.00 | -12.99 | PK |
| H | 4739.092 | 43.43 | 7.10 | 37.24 | 43.50 | 44.27 | 54.00 | -9.73 | AV |
| H | 10480.064 | 51.62 | 8.46 | 38.57 | 44.50 | 54.15 | 68.20 | -14.05 | PK |
| H | 10480.064 | 43.07 | 8.46 | 38.57 | 44.50 | 45.60 | 54.00 | -8.40 | AV |
| H | 15720.085 | 51.90 | 10.12 | 38.38 | 44.10 | 56.30 | 74.00 | -17.70 | PK |
| H | 15720.085 | 41.31 | 10.12 | 38.38 | 44.10 | 45.71 | 54.00 | -8.29 | AV |

Note: PK value is lower than the Average value limit, So average didn't record.

The 26.5-40G amplitude of spurious emissions that are attenuated by more than 20dB below the permissible value has no need to be reported.

Emission level (dBuV/m) = 20 log Emission level (uV/m).

Corrected Reading: Antenna Factor + Cable Loss + Read Level - Preamp Factor = Level.

Test Mode is MIMO Mode.

| | |
|-------------|------------------------|
| Test Mode : | TX(5.1G) - 802.11 AC40 |
|-------------|------------------------|

| Polar (H/V) | Frequency (MHz) | Meter Reading (dBuV) | Cable loss (dB) | Antenna Factor (dB/m) | Preamp Factor (dB) | Emission Level (dBuV/m) | Limits (dBuV/m) | Margin (dB) | Detector Type |
|------------------------------------|-----------------|----------------------|-----------------|-----------------------|--------------------|-------------------------|-----------------|-------------|---------------|
| Low Channel (5190 MHz)-Above 1G | | | | | | | | | |
| V | 4434.139 | 61.43 | 5.94 | 35.40 | 44.00 | 58.77 | 74.00 | -15.23 | PK |
| V | 4434.139 | 43.60 | 5.94 | 35.40 | 44.00 | 40.94 | 54.00 | -13.06 | AV |
| V | 10380.115 | 60.20 | 8.46 | 39.75 | 44.50 | 63.91 | 68.20 | -4.29 | PK |
| V | 10380.115 | 43.70 | 8.46 | 39.75 | 44.50 | 47.41 | 54.00 | -6.59 | AV |
| V | 15570.108 | 62.59 | 10.12 | 38.80 | 44.10 | 67.41 | 74.00 | -6.59 | PK |
| V | 15570.108 | 43.74 | 10.12 | 38.80 | 42.70 | 49.96 | 54.00 | -4.04 | AV |
| H | 4434.176 | 60.05 | 5.94 | 35.18 | 44.00 | 57.17 | 74.00 | -16.83 | PK |
| H | 4434.176 | 43.84 | 5.94 | 35.18 | 44.00 | 40.96 | 54.00 | -13.04 | AV |
| H | 10380.004 | 54.16 | 8.46 | 38.71 | 44.50 | 56.83 | 68.20 | -11.37 | PK |
| H | 10380.004 | 41.74 | 8.46 | 38.71 | 44.50 | 44.41 | 54.00 | -9.59 | AV |
| H | 15570.106 | 51.03 | 10.12 | 38.38 | 44.10 | 55.43 | 74.00 | -18.57 | PK |
| H | 15570.106 | 43.37 | 10.12 | 38.38 | 44.10 | 47.77 | 54.00 | -6.23 | AV |
| middle Channel (5230 MHz)-Above 1G | | | | | | | | | |
| V | 4739.083 | 64.84 | 6.48 | 36.35 | 44.05 | 63.62 | 74.00 | -10.38 | PK |
| V | 4739.083 | 43.10 | 6.48 | 36.35 | 44.05 | 41.88 | 54.00 | -12.12 | AV |
| V | 10460.021 | 63.50 | 8.47 | 37.88 | 44.51 | 65.34 | 68.20 | -2.86 | PK |
| V | 10460.021 | 43.76 | 8.47 | 37.88 | 44.51 | 45.60 | 54.00 | -8.40 | AV |
| V | 15690.160 | 60.31 | 10.12 | 38.80 | 44.10 | 65.13 | 74.00 | -8.87 | PK |
| V | 15690.160 | 43.05 | 10.12 | 38.80 | 42.70 | 49.27 | 54.00 | -4.73 | AV |
| H | 4739.134 | 63.38 | 6.48 | 36.37 | 44.05 | 62.18 | 74.00 | -11.82 | PK |
| H | 4739.134 | 43.50 | 6.48 | 36.37 | 44.05 | 42.30 | 54.00 | -11.70 | AV |
| H | 10460.124 | 52.59 | 8.47 | 38.64 | 44.50 | 55.20 | 68.20 | -13.00 | PK |
| H | 10460.124 | 43.37 | 8.47 | 38.64 | 44.50 | 45.98 | 54.00 | -8.02 | AV |
| H | 15690.112 | 51.59 | 10.12 | 38.38 | 44.10 | 55.99 | 74.00 | -18.01 | PK |
| H | 15690.112 | 40.80 | 10.12 | 38.38 | 44.10 | 45.20 | 54.00 | -8.80 | AV |

Note: PK value is lower than the Average value limit, So average didn't record.

The 26.5-40G amplitude of spurious emissions that are attenuated by more than 20dB below the permissible value has no need to be reported.

Emission level (dBuV/m) = 20 log Emission level (uV/m).

Corrected Reading: Antenna Factor + Cable Loss + Read Level - Preamp Factor = Level.

Test Mode is MIMO Mode.

| | |
|-------------|------------------------|
| Test Mode : | TX(5.1G) - 802.11 AC80 |
|-------------|------------------------|

| Polar (H/V) | Frequency | Meter Reading | Cable loss | Antenna Factor | Preamp Factor | Emission Level | Limits | Margin | Detector Type |
|---------------------|-----------|------------------|---------------|-------------------|------------------|-------------------|--------------|--------|------------------|
| | (MHz) | (dBuV) | (dB) | dB/m | (dB) | (dBuV/m) | (dBuV/ m) | (dB) | |
| (5210 MHz)-Above 1G | | | | | | | | | |
| V | 4434.095 | 60.96 | 5.94 | 35.40 | 44.00 | 58.30 | 74.00 | -15.70 | PK |
| V | 4434.095 | 43.41 | 5.94 | 35.40 | 44.00 | 40.75 | 54.00 | -13.25 | AV |
| V | 10420.176 | 61.87 | 8.46 | 39.75 | 44.50 | 65.58 | 68.20 | -2.62 | PK |
| V | 10420.176 | 43.38 | 8.46 | 39.75 | 44.50 | 47.09 | 54.00 | -6.91 | AV |
| V | 15630.047 | 64.21 | 10.12 | 38.80 | 44.10 | 69.03 | 74.00 | -4.97 | PK |
| V | 15630.047 | 43.36 | 10.12 | 38.80 | 42.70 | 49.58 | 54.00 | -4.42 | AV |
| H | 4434.141 | 60.29 | 5.94 | 35.18 | 44.00 | 57.41 | 74.00 | -16.59 | PK |
| H | 4434.141 | 43.05 | 5.94 | 35.18 | 44.00 | 40.17 | 54.00 | -13.83 | AV |
| H | 10420.033 | 53.78 | 8.46 | 38.71 | 44.50 | 56.45 | 68.20 | -11.75 | PK |
| H | 10420.033 | 40.78 | 8.46 | 38.71 | 44.50 | 43.45 | 54.00 | -10.55 | AV |
| H | 15630.034 | 52.39 | 10.12 | 38.38 | 44.10 | 56.79 | 74.00 | -17.21 | PK |
| H | 15630.034 | 43.43 | 10.12 | 38.38 | 44.10 | 47.83 | 54.00 | -6.17 | AV |

Note: PK value is lower than the Average value limit, So average didn't record.

The 26.5-40G amplitude of spurious emissions that are attenuated by more than 20dB below the permissible value has no need to be reported.

Emission level (dBuV/m) = 20 log Emission level (uV/m).

Corrected Reading: Antenna Factor + Cable Loss + Read Level - Preamp Factor = Level.

Test Mode is MIMO Mode.

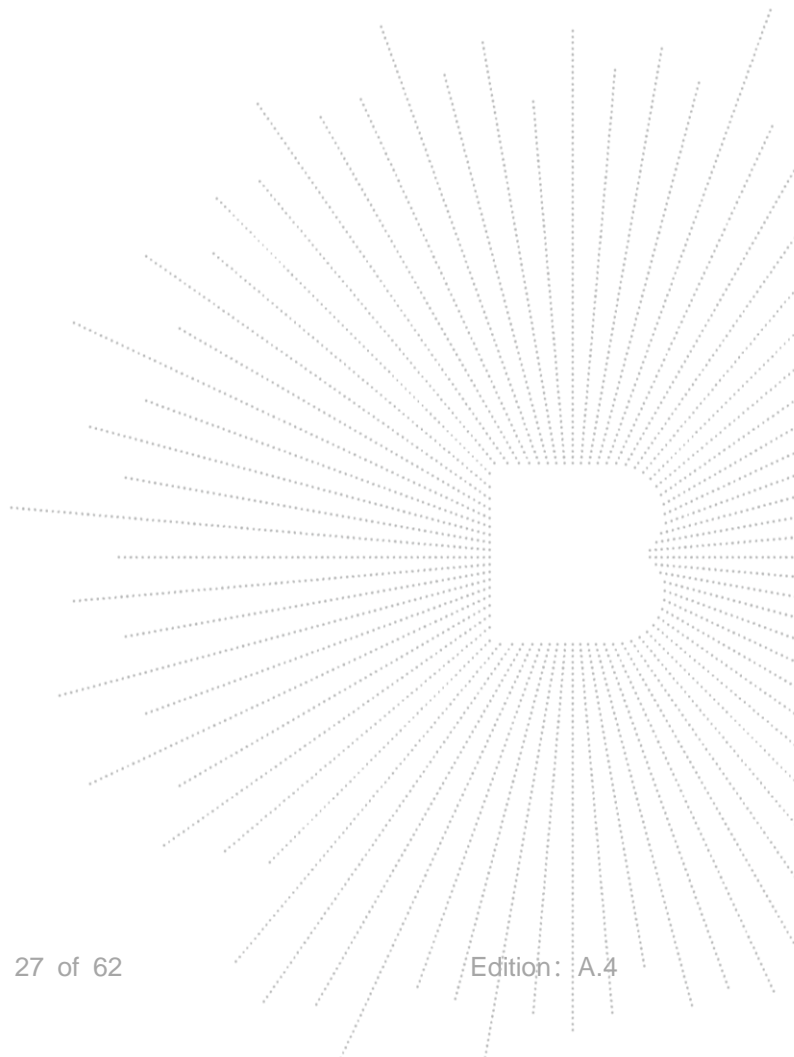

8. Power Spectral Density Test

8.1 Block Diagram Of Test Setup



8.2 Limit

For the band 5.15-5.25 GHz,

(i) For an outdoor access point operating in the band 5.15-5.25 GHz, the maximum power spectral density shall not exceed 17 dBm in any 1 megahertz band. If transmitting antennas of directional gain greater than 6 dBi are used, both the maximum conducted output power and the maximum power spectral density shall be reduced by the amount in dB that the directional gain of the antenna exceeds 6 dBi. The maximum e.i.r.p. at any elevation angle above 30 degrees as measured from the horizon must not exceed 125 mW (21 dBm).

(ii) For an indoor access point operating in the band 5.15-5.25 GHz, the maximum power spectral density shall not exceed 17 dBm in any 1 megahertz band. If transmitting antennas of directional gain greater than 6 dBi are used, both the maximum conducted output power and the maximum power spectral density shall be reduced by the amount in dB that the directional gain of the antenna exceeds 6 dBi.

(iii) For fixed point-to-point access points operating in the band 5.15-5.25 GHz, the maximum power spectral density shall not exceed 17 dBm in any 1 megahertz band. Fixed point-to-point U-NII devices may employ antennas with directional gain up to 23 dBi without any corresponding reduction in the maximum conducted output power or maximum power spectral density. For fixed point-to-point transmitters that employ a directional antenna gain greater than 23 dBi, a 1 dB reduction in maximum conducted output power and maximum power spectral density is required for each 1 dB of antenna gain in excess of 23 dBi. Fixed, point-to-point operations exclude the use of point-to-multipoint systems, omnidirectional applications, and multiple collocated transmitters transmitting the same information. The operator of the U-NII device, or if the equipment is professionally installed, the installer, is responsible for ensuring that systems employing high gain directional antennas are used exclusively for fixed, point-to-point operations.

(iv) For client devices in the 5.15-5.25 GHz band, the maximum power spectral density shall not exceed 11 dBm in any 1 megahertz band. If transmitting antennas of directional gain greater than 6 dBi are used, both the maximum conducted output power and the maximum power spectral density shall be reduced by the amount in dB that the directional gain of the antenna exceeds 6 dBi.

For the band 5.725-5.85 GHz

(3) For the band 5.725-5.85 GHz, the maximum power spectral density shall not exceed 30 dBm in any 500-kHz band. If transmitting antennas of directional gain greater than 6 dBi are used, both the maximum conducted output power and the maximum power spectral density shall be reduced by the amount in dB that the directional gain of the antenna exceeds 6 dBi.

8.3 Test Procedure

For devices operating in the bands 5.15-5.25 GHz, 5.25-5.35 GHz, and 5.47-5.725 GHz, the above procedures make use of 1 MHz RBW to satisfy directly the 1 MHz reference bandwidth specified in § 15.407(a)(5). For devices operating in the band 5.725-5.85 GHz, the rules specify a measurement bandwidth of 500 kHz. Many spectrum analyzers do not have 500 kHz RBW, thus a narrower RBW may need to be used. The rules permit the use of a RBWs less than 1 MHz, or 500 kHz, “provided that the measured power is integrated over the full reference bandwidth” to show the total power over the specified measurement bandwidth (i.e., 1 MHz, or 500 kHz). If measurements are performed using a reduced resolution bandwidth (< 1 MHz, or < 500 kHz) and integrated over 1 MHz, or 500 KHz bandwidth, the following adjustments to the procedures apply:

a) Set $RBW \geq 1/T$, where T is defined in section II.B.I.a).

b) Set $VBW \geq 3 RBW$.

c) If measurement bandwidth of Maximum PSD is specified in 500 kHz, add $10\log(500\text{kHz}/RBW)$ to the measured result, whereas RBW (< 500 KHz) is the reduced resolution bandwidth of the spectrum analyzer set during measurement.

d) If measurement bandwidth of Maximum PSD is specified in 1 MHz, add $10\log(1\text{MHz}/RBW)$ to the measured result, whereas RBW (< 1 MHz) is the reduced resolution bandwidth of spectrum analyzer set during measurement.

e) Care must be taken to ensure that the measurements are performed during a period of continuous transmission or are corrected upward for duty cycle.

Note: As a practical matter, it is recommended to use reduced RBW of 100 KHz for the sections 5.c) and 5.d) above, since RBW=100 KHZ is available on nearly all spectrum analyzers.

8.4 EUT Operating Conditions

The EUT was configured for testing in a typical fashion (as a customer would normally use it). The EUT has been programmed to continuously transmit during test. This operating condition was tested and used to collect the included data.

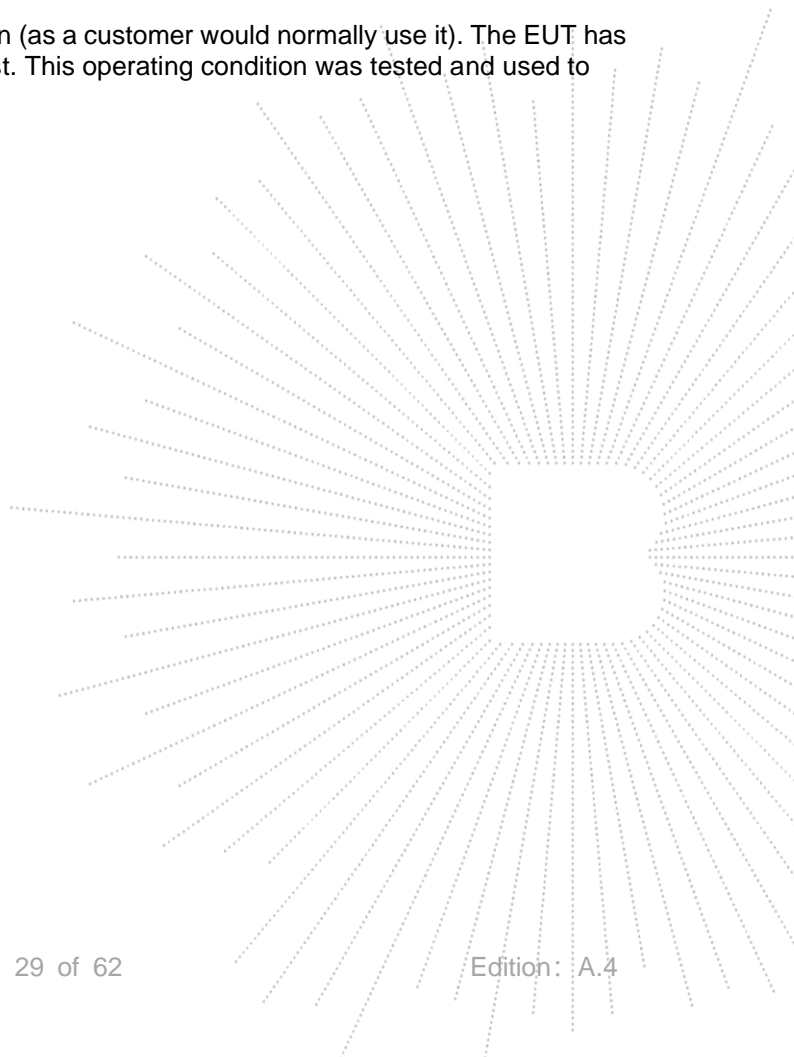

8.5 Test Result

| | | | |
|---------------|-------------------------------------|---------------------|-------|
| Temperature : | 26 °C | Relative Humidity : | 54% |
| Pressure : | 101kPa | Test Voltage : | DC 9V |
| Test Mode : | TX Frequency U-NII-1 (5180-5240MHz) | | |

| Test Mode | Frequency | Measured Power Density (dBm/MHz) | Limit (dBm/MHz) | Result |
|-------------|-----------|----------------------------------|-----------------|--------|
| 802.11 a | 5180 MHz | 2.652 | 11 | PASS |
| | 5200 MHz | 1.941 | 11 | PASS |
| | 5240 MHz | 2.690 | 11 | PASS |
| 802.11 n20 | 5180 MHz | 0.454 | 11 | PASS |
| | 5200 MHz | -0.451 | 11 | PASS |
| | 5240 MHz | -0.037 | 11 | PASS |
| 802.11 n40 | 5190 MHz | -1.904 | 11 | PASS |
| | 5230 MHz | -2.160 | 11 | PASS |
| 802.11 AC20 | 5180 MHz | -0.010 | 11 | PASS |
| | 5200 MHz | 0.974 | 11 | PASS |
| | 5240 MHz | -0.267 | 11 | PASS |
| 802.11 AC40 | 5190 MHz | -1.814 | 11 | PASS |
| | 5230 MHz | -2.087 | 11 | PASS |
| 802.11 AC80 | 5210 MHz | -1.889 | 11 | PASS |

(802.11a) PSD plot on channel 36

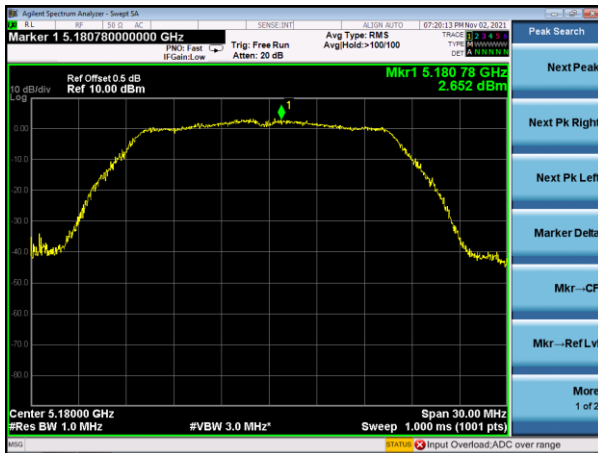

(802.11n20) PSD plot on channel 36



(802.11a) PSD plot on channel 40

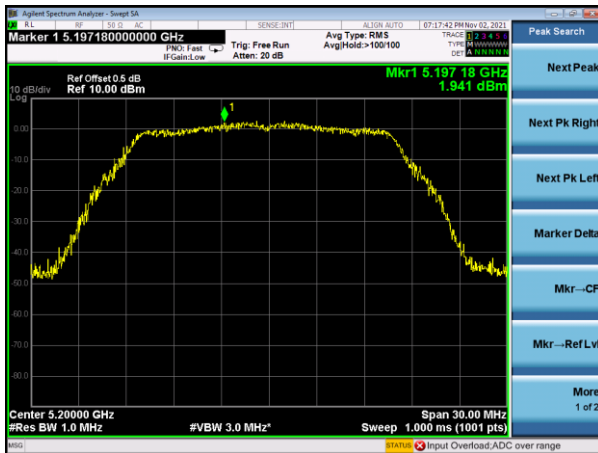

(802.11n20) PSD plot on channel 40

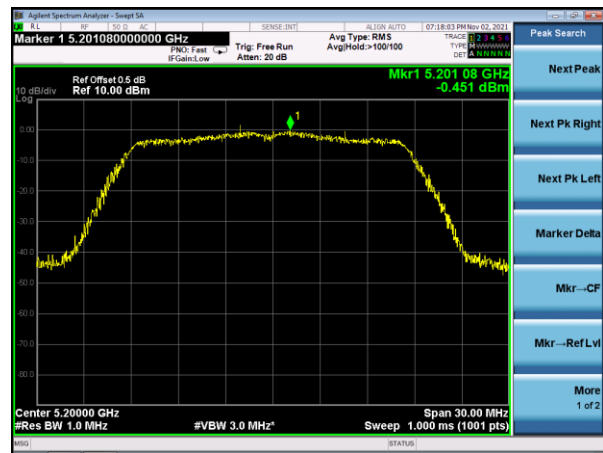

(802.11a) PSD plot on channel 48



(802.11n20) PSD plot on channel 48

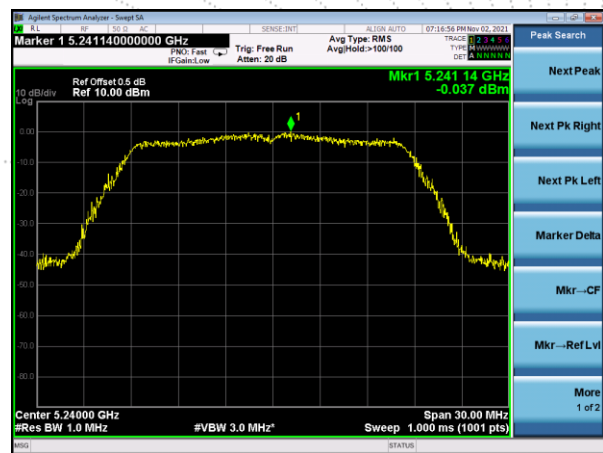

(802.11n40) PSD plot on channel 38

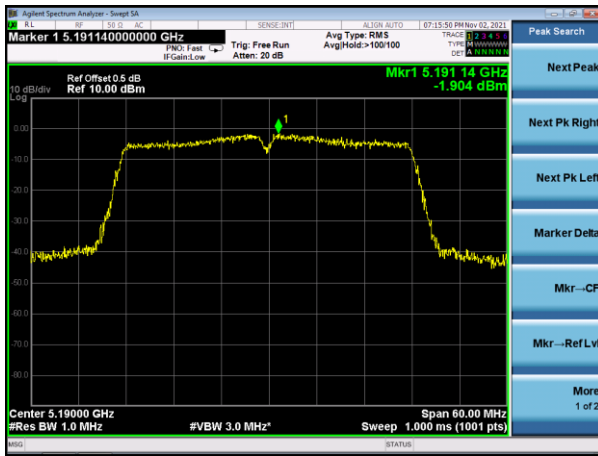

(802.11ac20) PSD plot on channel 36

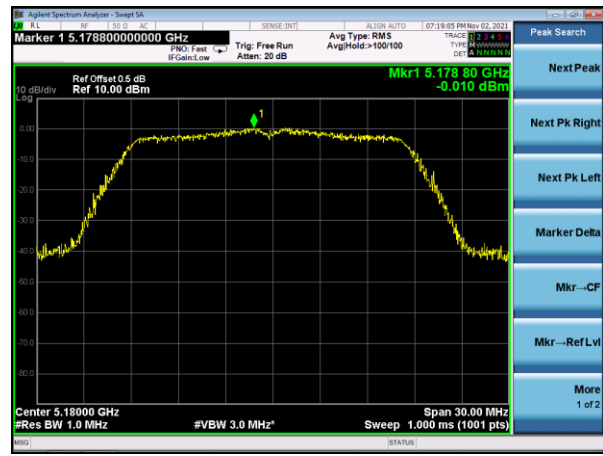

(802.11n40) PSD plot on channel 46

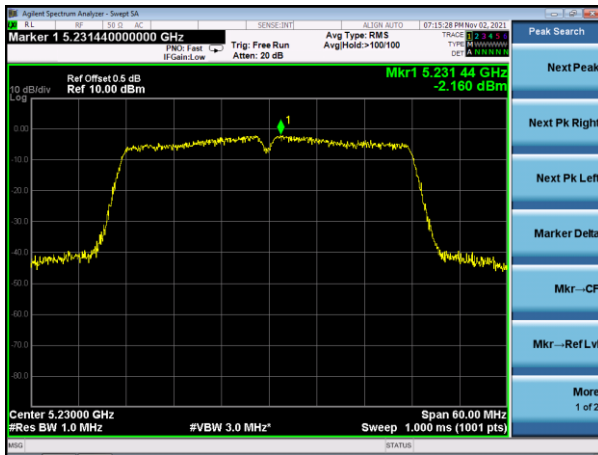

(802.11ac20) PSD plot on channel 40

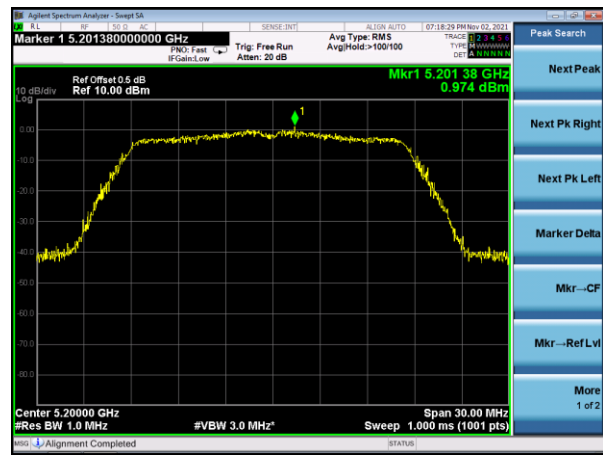

(802.11ac20) PSD plot on channel 48

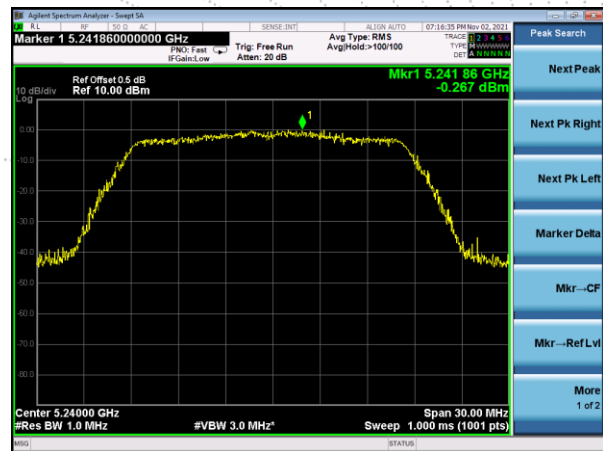

(802.11ac40) PSD plot on channel 38



(802.11ac80) PSD plot on channel 42



(802.11ac40) PSD plot on channel 46

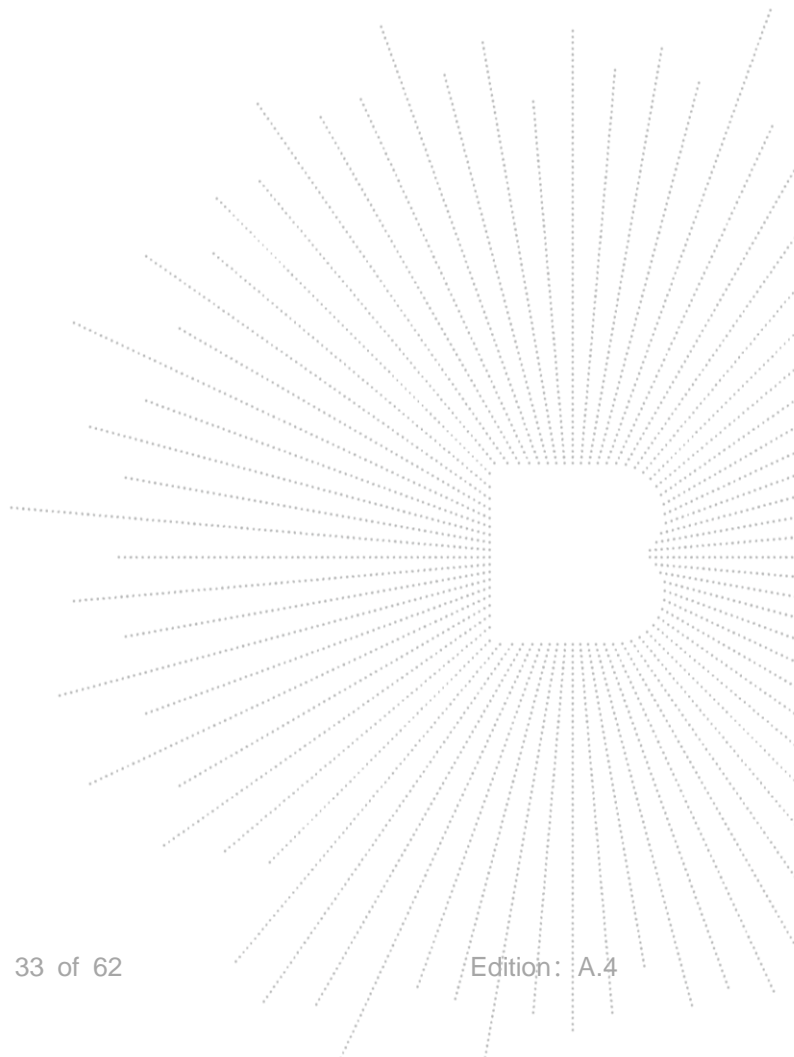

9. 26dB & 99% Emission Bandwidth

9.1 Block Diagram Of Test Setup

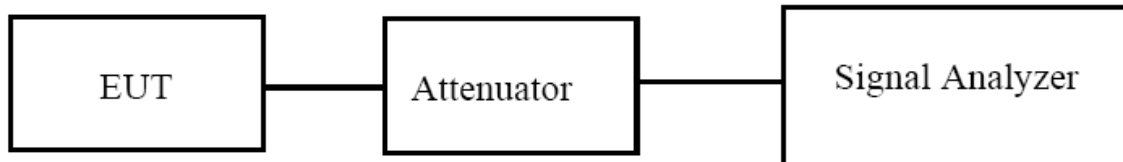

9.2 Limit

The maximum power spectral density is measured as a conducted emission by direct connection of a calibrated test instrument to the equipment under test. If the device cannot be connected directly, alternative techniques acceptable to the Commission may be used. Measurements in the 5.725-5.85 GHz band are made over a reference bandwidth of 500 kHz or the 26 dB emission bandwidth of the device, whichever is less. Measurements in the 5.15-5.25 GHz, 5.25-5.35 GHz, and the 5.47-5.725 GHz bands are made over a bandwidth of 1 MHz or the 26 dB emission bandwidth of the device, whichever is less. A narrower resolution bandwidth can be used, provided that the measured power is integrated over the full reference bandwidth.

9.3 Test Procedure

- a) Set RBW = approximately 1% of the emission bandwidth.
- b) Set the VBW > RBW.
- c) Detector = Peak.
- d) Trace mode = max hold.
- e) Measure the maximum width of the emission that is 26 dB down from the maximum of the emission. Compare this with the RBW setting of the analyzer. Readjust RBW and repeat measurement as needed until the RBW/EBW ratio is approximately 1%.

The following procedure shall be used for measuring (99 %) power bandwidth:

1. Set center frequency to the nominal EUT channel center frequency.
2. Set span = 1.5 times to 5.0 times the OBW.
3. Set RBW = 1 % to 5 % of the OBW
4. Set VBW $\geq 3 \cdot$ RBW
5. Video averaging is not permitted. Where practical, a sample detection and single sweep mode shall be used. Otherwise, peak detection and max hold mode (until the trace stabilizes) shall be used.
6. Use the 99 % power bandwidth function of the instrument (if available).
7. If the instrument does not have a 99 % power bandwidth function, the trace data points are recovered and directly summed in power units. The recovered amplitude data points, beginning at the lowest frequency, are placed in a running sum until 0.5 % of the total is reached; that frequency is recorded as the lower frequency. The process is repeated until 99.5 % of the total is reached; that frequency is recorded as the upper frequency. The 99% occupied bandwidth is the difference between these two frequencies.

9.4 EUT Operating Conditions

The EUT was configured for testing in a typical fashion (as a customer would normally use it). The EUT has been programmed to continuously transmit during test. This operating condition was tested and used to collect the included data.

9.5 Test Result

| | | | |
|---------------|-------------------------------------|---------------------|-------|
| Temperature : | 26 °C | Relative Humidity : | 54% |
| Pressure : | 101kPa | Test Voltage : | DC 9V |
| Test Mode : | TX Frequency U-NII-1 (5180-5240MHz) | | |

| Mode | Channel | Frequency (MHz) | 99% bandwidth(MHz) | 26dB bandwidth(MHz) | Result |
|-------------|---------|-----------------|--------------------|---------------------|--------|
| 802.11a | CH36 | 5180 | 16.84 | 21.36 | Pass |
| | CH40 | 5200 | 16.82 | 20.97 | Pass |
| | CH48 | 5240 | 16.80 | 21.35 | Pass |
| 802.11 n20 | CH36 | 5180 | 17.87 | 21.31 | Pass |
| | CH40 | 5200 | 17.86 | 21.63 | Pass |
| | CH48 | 5240 | 17.86 | 21.56 | Pass |
| 802.11 n40 | CH 38 | 5190 | 36.29 | 40.56 | Pass |
| | CH 46 | 5230 | 36.32 | 40.66 | Pass |
| 802.11 AC20 | CH36 | 5180 | 17.93 | 21.50 | Pass |
| | CH40 | 5200 | 17.95 | 21.56 | Pass |
| | CH48 | 5240 | 17.92 | 21.44 | Pass |
| 802.11 AC40 | CH 38 | 5190 | 36.36 | 40.53 | Pass |
| | CH 46 | 5230 | 36.43 | 40.79 | Pass |
| 802.11 AC80 | CH 42 | 5210 | 75.39 | 81.03 | Pass |

Test plot

(802.11a) 26dB&99%Bandwidth plot on channel 36

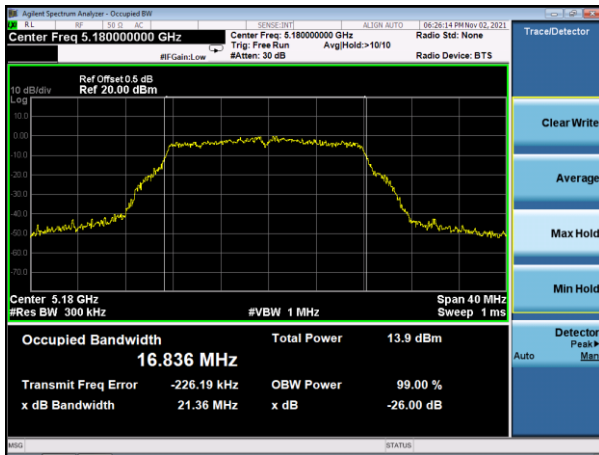

(802.11 n20) 26dB&99%Bandwidth plot on channel 36

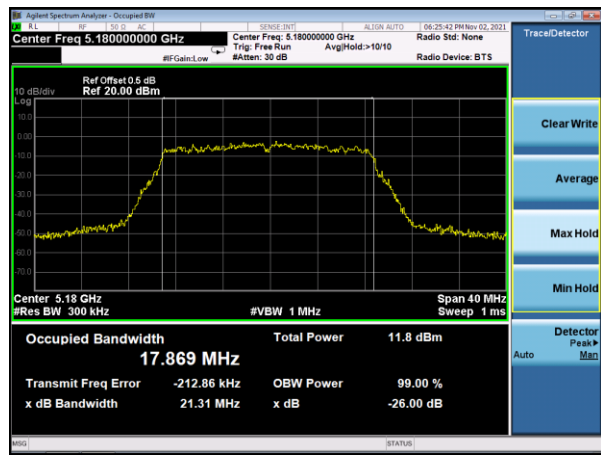

(802.11a) 26dB&99%Bandwidth plot on channel 40

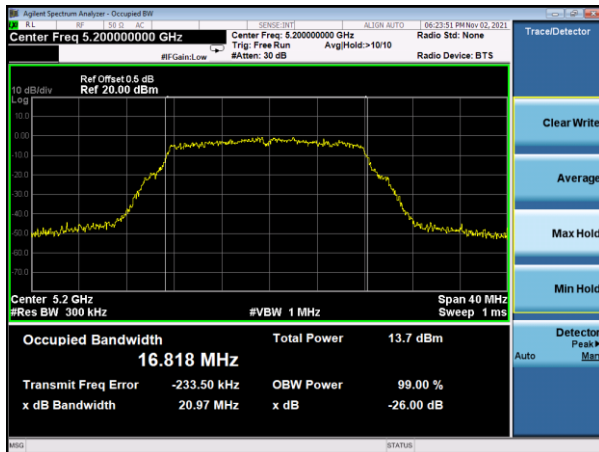

(802.11 n20) 26dB&99%Bandwidth plot on channel 40

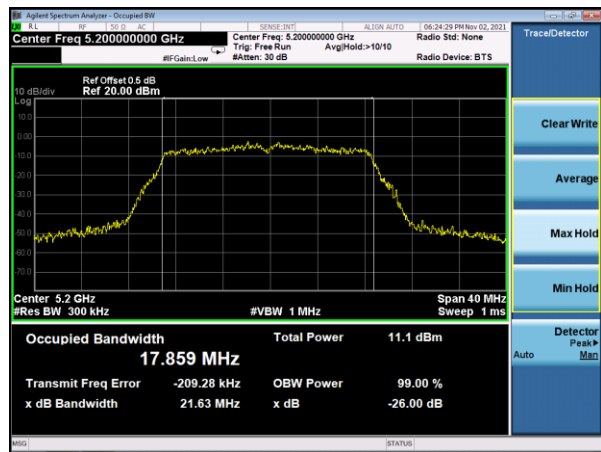

(802.11a) 26dB&99%Bandwidth plot on channel 48

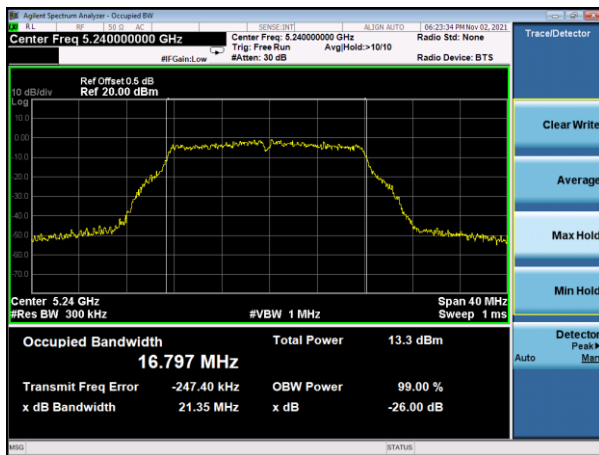

(802.11 n20) 26dB&99%Bandwidth plot on channel 48

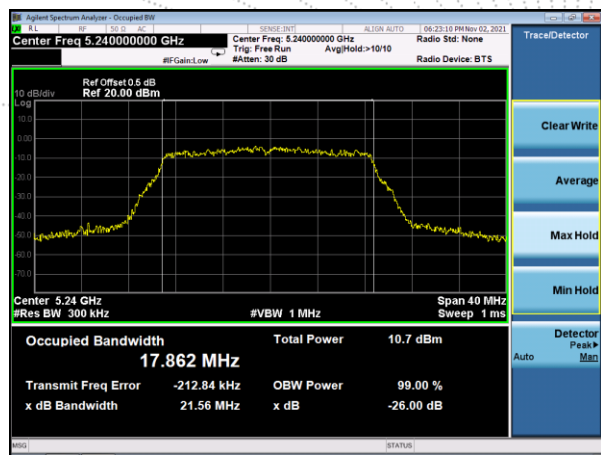

Test plot

(802.11 n40) 26dB&99%Bandwidth plot on channel 38

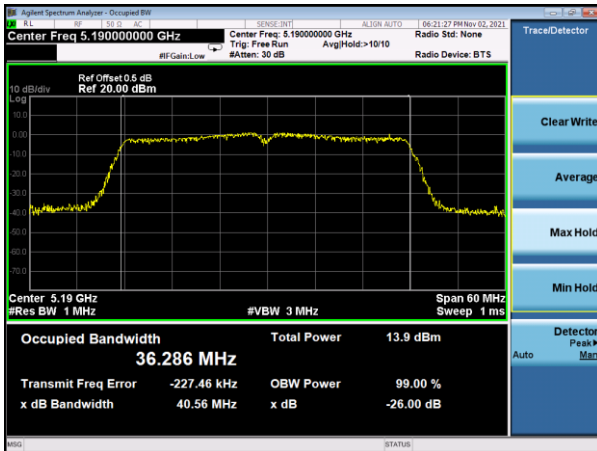

(802.11 AC20) -26dB&99%Bandwidth plot on channel 36

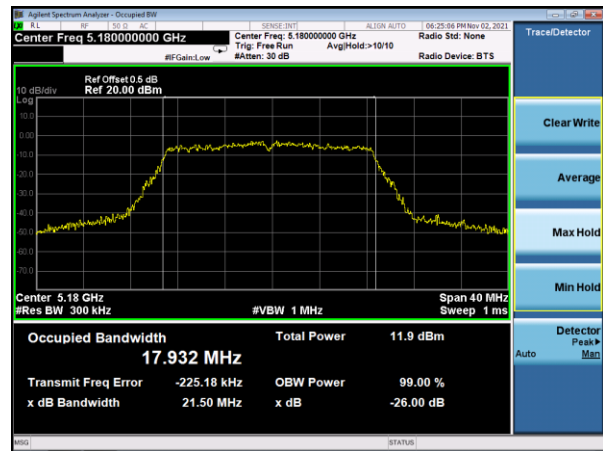

(802.11 n40) 26dB&99%Bandwidth plot on channel 46

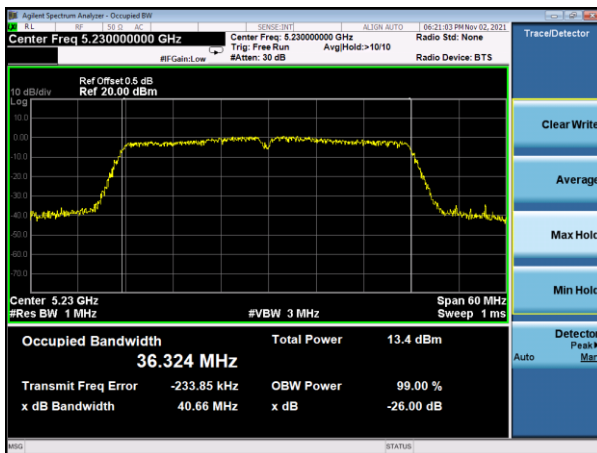

(802.11 AC20) -26dB&99%Bandwidth plot on channel 40

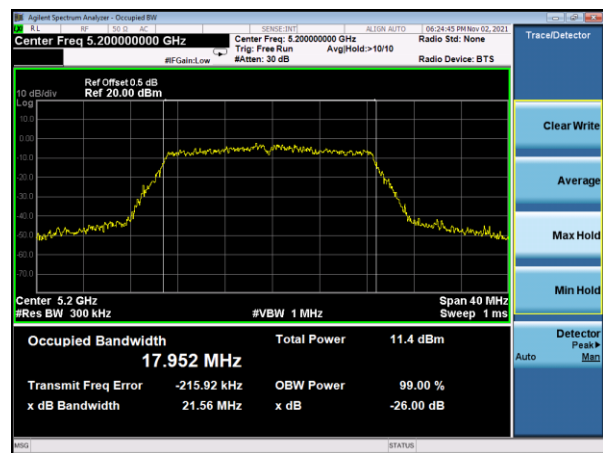

(802.11 AC20) -26dB&99%Bandwidth plot on channel 48

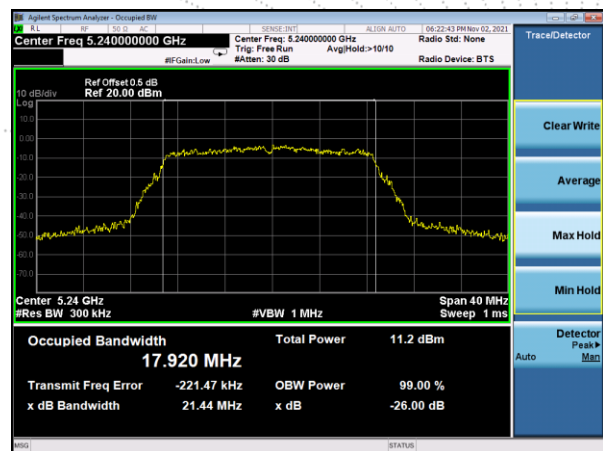

Test plot

(802.11 AC40) -26dB&99%Bandwidth plot on channel 38

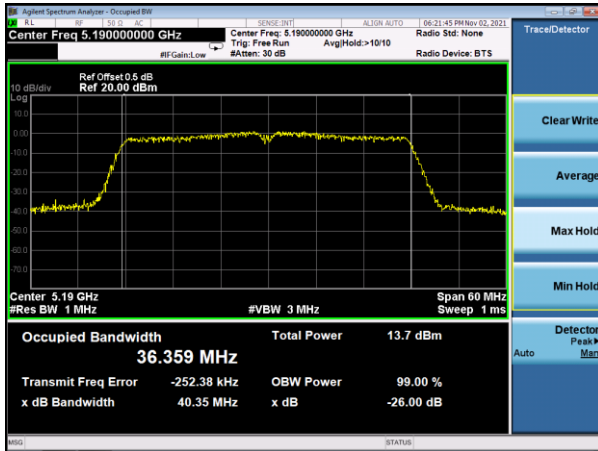

(802.11 AC80) -26dB&99%Bandwidth plot on channel 42

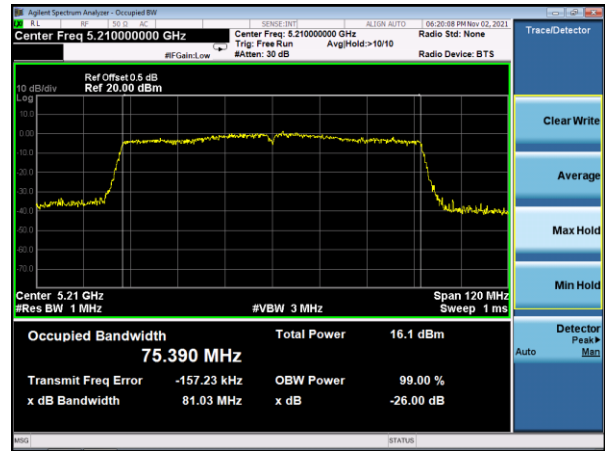

(802.11 AC40) -26dB&99%Bandwidth plot on channel 46

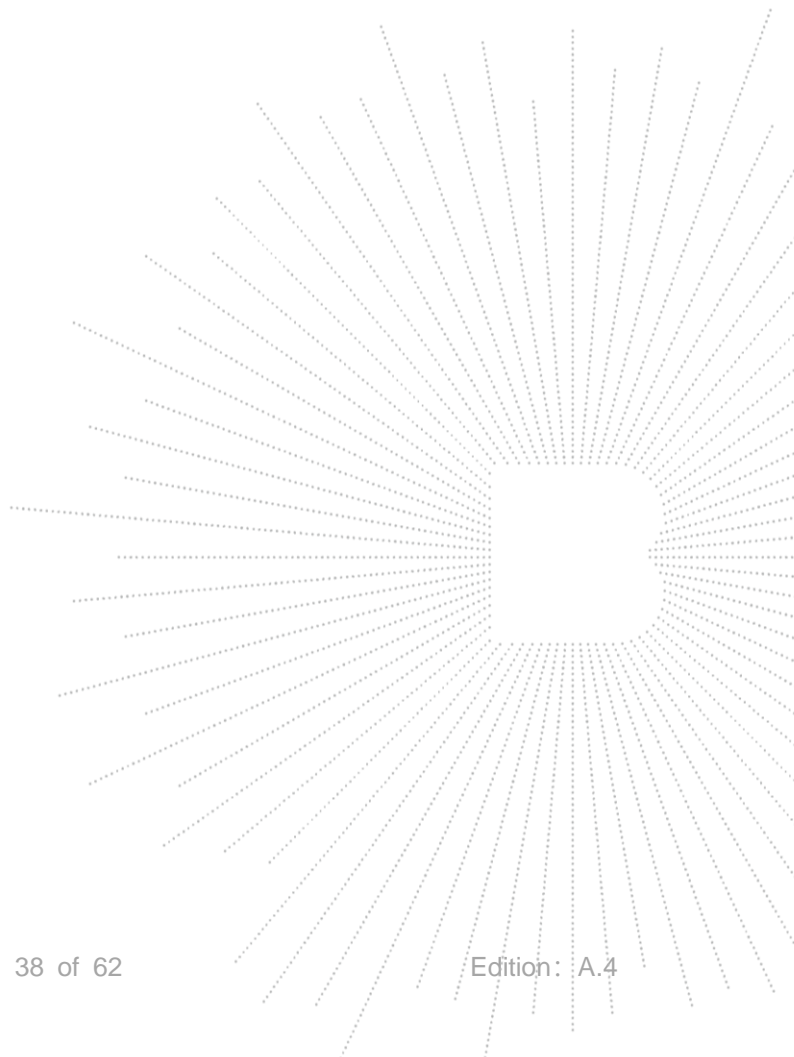
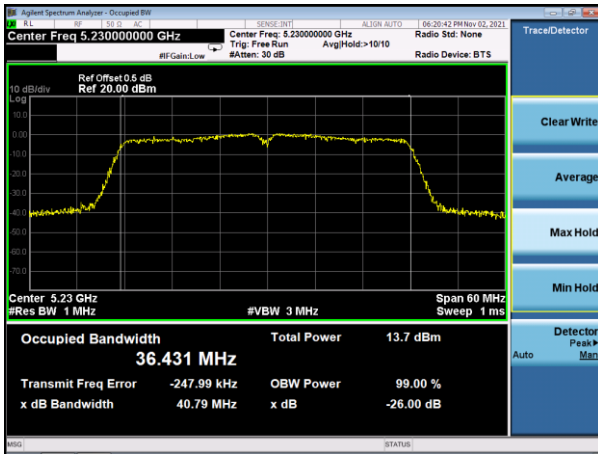

10. Maximum Conducted Output Power

10.1 Block Diagram Of Test Setup

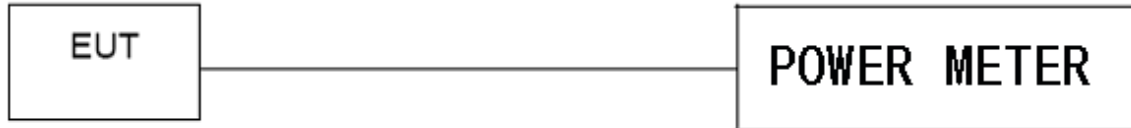

10.2 Limit

According to FCC §15.407

The maximum conducted output power should not exceed:

| Frequency Band(MHz) | Limit |
|---------------------|-------|
| 5150~5250 | 250mW |
| 5725~5850 | 1W |

10.3 Test Procedure

Maximum conducted output power may be measured using a spectrum analyzer/EMI receiver or an RF power meter.

1. Device Configuration

If possible, configure or modify the operation of the EUT so that it transmits continuously at its maximum power control level (see section II.B.).

a) The intent is to test at 100 percent duty cycle; however a small reduction in duty cycle (to no lower than 98 percent) is permitted if required by the EUT for amplitude control purposes. Manufacturers are expected to provide software to the test lab to permit such continuous operation.

b) If continuous transmission (or at least 98 percent duty cycle) cannot be achieved due to hardware limitations (e.g., overheating), the EUT shall be operated at its maximum power control level with the transmit duration as long as possible and the duty cycle as high as possible.

2. Measurement using a Spectrum Analyzer or EMI Receiver (SA)

Measurement of maximum conducted output power using a spectrum analyzer requires integrating the spectrum across a frequency span that encompasses, at a minimum, either the EBW or the 99-percent occupied bandwidth of the signal.¹ However, the EBW must be used to determine bandwidth dependent limits on maximum conducted output power in accordance with § 15.407(a).

a) The test method shall be selected as follows: (i) Method SA-1 or SA-1 Alternative (averaging with the EUT transmitting at full power throughout each sweep) shall be applied if either of the following conditions can be satisfied:

- The EUT transmits continuously (or with a duty cycle \geq 98 percent).
- Sweep triggering or gating can be implemented in a way that the device transmits at the maximum power control level throughout the duration of each of the instrument sweeps to be averaged. This condition can generally be achieved by triggering the instrument's sweep if the duration of the sweep (with the analyzer configured as in Method SA-1, below) is equal to or shorter than the duration T of each transmission from the EUT and if those transmissions exhibit full power throughout their durations.

(ii) Method SA-2 or SA-2 Alternative (averaging across on and off times of the EUT transmissions, followed by duty cycle correction) shall be applied if the conditions of (i) cannot be achieved and the transmissions exhibit a constant duty cycle during the measurement duration. Duty cycle will be considered

to be constant if variations are less than ± 2 percent.

(iii) Method SA-3 (RMS detection with max hold) or SA-3 Alternative (reduced VBW with max hold) shall be applied if the conditions of (i) and (ii) cannot be achieved.

b) Method SA-1 (trace averaging with the EUT transmitting at full power throughout each sweep): (i) Set span to encompass the entire emission bandwidth (EBW) (or, alternatively, the entire 99% occupied bandwidth) of the signal.

(ii) Set RBW = 1 MHz.

(iii) Set VBW ≥ 3 MHz.

(iv) Number of points in sweep ≥ 2 Span / RBW. (This ensures that bin-to-bin spacing is \leq RBW/2, so that narrowband signals are not lost between frequency bins.)

(v) Sweep time = auto.

(vi) Detector = RMS (i.e., power averaging), if available. Otherwise, use sample detector mode.

(vii) If transmit duty cycle < 98 percent, use a video trigger with the trigger level set to enable triggering only on full power pulses. Transmitter must operate at maximum power control level for the entire duration of every sweep. If the EUT transmits continuously (i.e., with no off intervals) or at duty cycle ≥ 98 percent, and if each transmission is entirely at the maximum power control level, then the trigger shall be set to "free run".

(viii) Trace average at least 100 traces in power averaging (i.e., RMS) mode.

(ix) Compute power by integrating the spectrum across the EBW (or, alternatively, the entire 99% occupied bandwidth) of the signal using the instrument's band power measurement function with band limits set equal to the EBW (or occupied bandwidth) band edges. If the instrument does not have a band power function, sum the spectrum

10.4 EUT Operating Conditions

The EUT was configured for testing in a typical fashion (as a customer would normally use it). The EUT has been programmed to continuously transmit during test. This operating condition was tested and used to collect the included data.

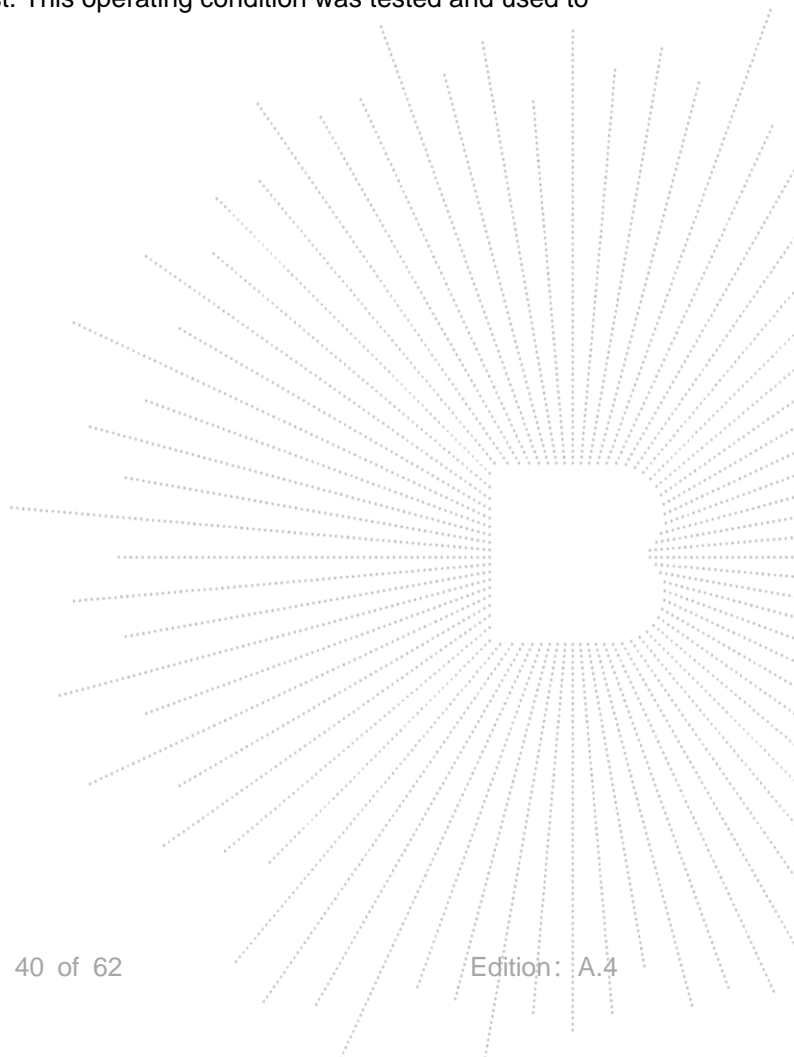

10.5 Test Result

| | | | |
|---------------|---|---------------------|-------|
| Temperature : | 26 °C | Relative Humidity : | 54% |
| Pressure : | 101kPa | Test Voltage : | DC 9V |
| Test Mode : | TX (5.1G) Mode Frequency U-NII-1 (5180-5240MHz) | | |

| Test Channel | Frequency | Maximum output power. Antenna port (AV) | LIMIT | Result |
|-----------------------------|-----------|---|-------|--------|
| | (MHz) | (dBm) | dBm | |
| TX 802.11a Mode | | | | |
| CH36 | 5180 | 11.590 | 23.98 | Pass |
| CH40 | 5200 | 11.290 | 23.98 | Pass |
| CH48 | 5240 | 10.671 | 23.98 | Pass |
| TX 802.11 n20M Mode | | | | |
| CH36 | 5180 | 9.343 | 23.98 | Pass |
| CH40 | 5200 | 9.268 | 23.98 | Pass |
| CH48 | 5240 | 9.284 | 23.98 | Pass |
| TX 802.11 n40M Mode | | | | |
| CH38 | 5190 | 8.226 | 23.98 | Pass |
| CH46 | 5230 | 7.763 | 23.98 | Pass |
| TX 802.11 AC20M Mode | | | | |
| CH36 | 5180 | 9.586 | 23.98 | Pass |
| CH40 | 5200 | 9.041 | 23.98 | Pass |
| CH48 | 5240 | 9.380 | 23.98 | Pass |
| TX 802.11 AC40M Mode | | | | |
| CH38 | 5190 | 7.901 | 23.98 | Pass |
| CH46 | 5230 | 6.905 | 23.98 | Pass |
| TX 802.11 AC80M Mode | | | | |
| CH42 | 5210 | 7.828 | 23.98 | Pass |

11. Out Of Band Emissions

11.1 Block Diagram Of Test Setup



11.2 Limit

According to FCC §15.407(b)

Undesirable emission limits. Except as shown in paragraph (b)(7) of this section, the maximum emissions outside of the frequency bands of operation shall be attenuated in accordance with the following limits:

(1) For transmitters operating in the 5.15-5.25 GHz band: All emissions outside of the 5.15-5.35 GHz band shall not exceed an e.i.r.p. of -27 dBm/MHz.

(2) All emissions shall be limited to a level of -27 dBm/MHz at 75 MHz or more above or below the band edge increasing linearly to 10 dBm/MHz at 25 MHz above or below the band edge, and from 25 MHz above or below the band edge increasing linearly to a level of 15.6 dBm/MHz at 5 MHz above or below the band edge, and from 5 MHz above or below the band edge increasing linearly to a level of 27 dBm/MHz at the band edge.

11.3 Test Procedure

1. Check the calibration of the measuring instrument using either an internal calibrator or a known signal from an external generator.
2. Position the EUT without connection to measurement instrument. Turn on the EUT and connect its antenna terminal to measurement instrument via a low loss cable. Then set it to any one measured frequency within its operating range, and make sure the instrument is operated in its linear range.
3. Set RBW of spectrum analyzer to 1 MHz with a convenient frequency span.
4. Measure the highest amplitude appearing on spectral display and set it as a reference level. Plot the graph with marking the highest point and edge frequency.
5. Repeat above procedures until all measured frequencies were complete.

11.4 EUT Operating Conditions

The EUT was configured for testing in a typical fashion (as a customer would normally use it). The EUT has been programmed to continuously transmit during test. This operating condition was tested and used to collect the included data

11.5 Test Result

| | | | |
|---------------|--------|---------------------|-------|
| Temperature : | 26 °C | Relative Humidity : | 54% |
| Pressure : | 101kPa | Test Voltage : | DC 9V |

5.1G

5.180~5.240 GHz

(802.11a) Band Edge, Left Side

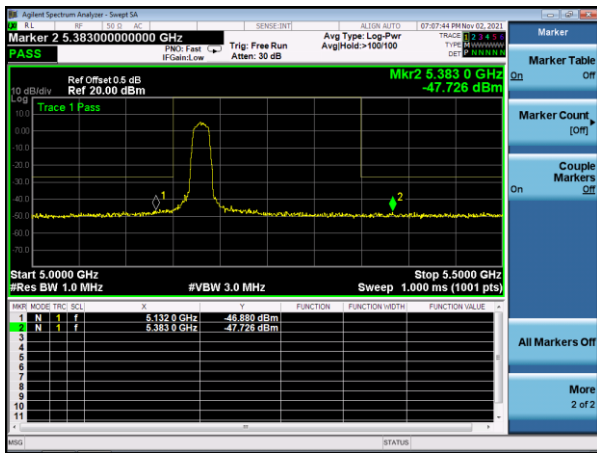

(802.11n20) Band Edge, Left Side

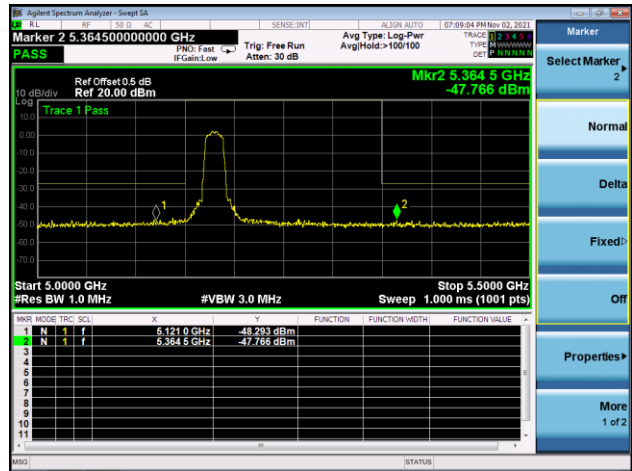

(802.11a) Band Edge, Right Side

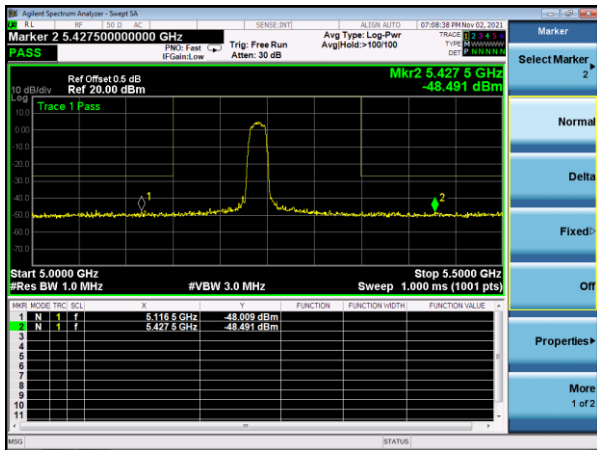

(802.11n20) Band Edge, Right Side

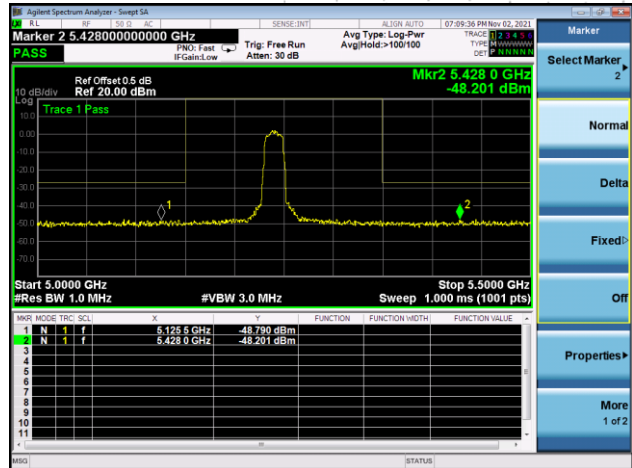

5.180~5.240 GHz

(802.11n40) Band Edge, Left Side

(802.11ac20) Band Edge, Left Side

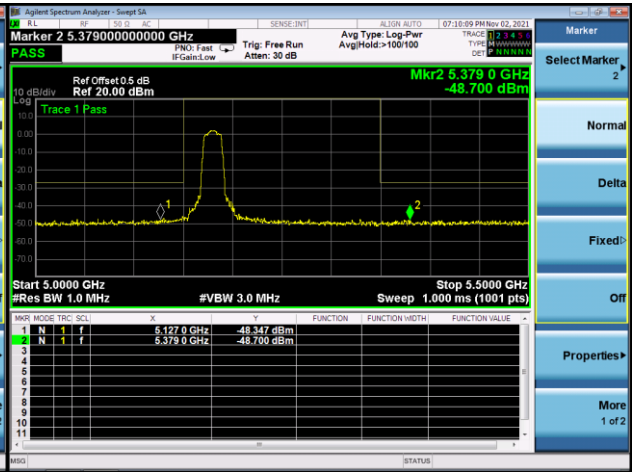
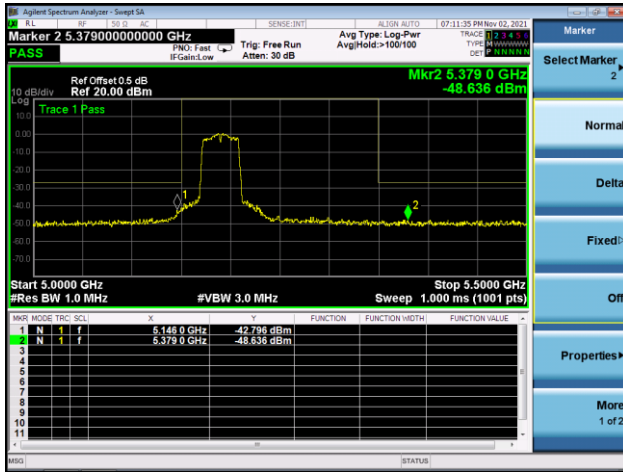

(802.11n40) Band Edge, Right Side

(802.11ac20) Band Edge, Right Side

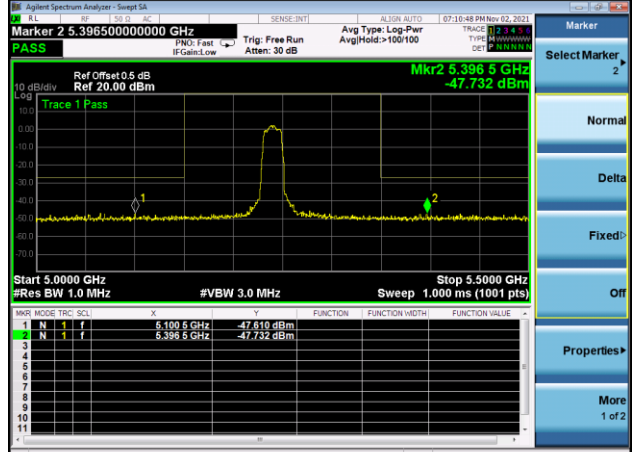
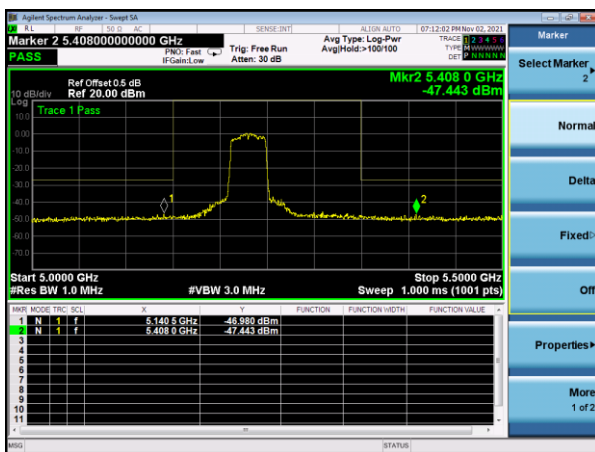

5.180~5.240 GHz

(802.11ac40) Band Edge, Left Side

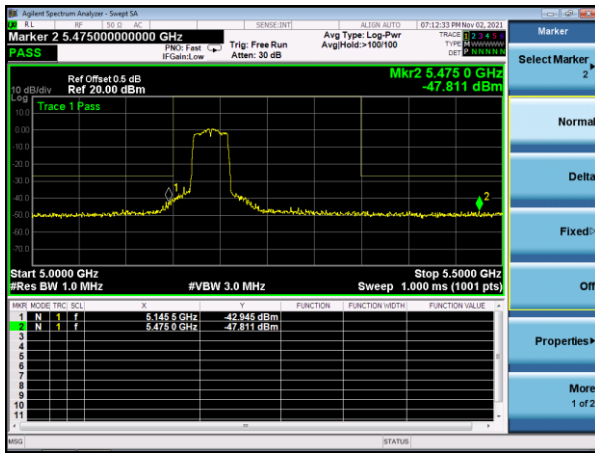

(802.11ac80) Band Edge, Left Side

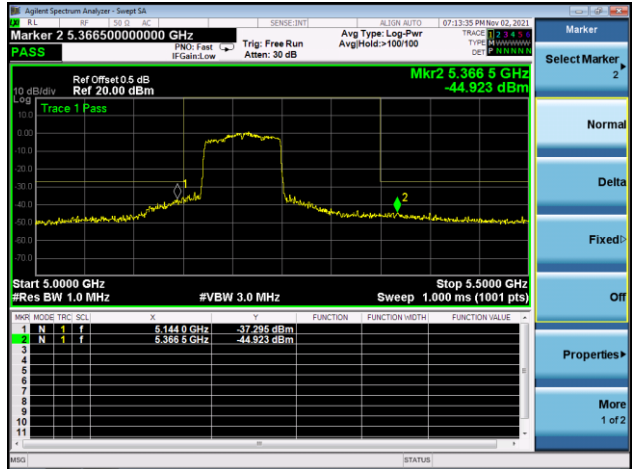

(802.11ac40) Band Edge, Right Side

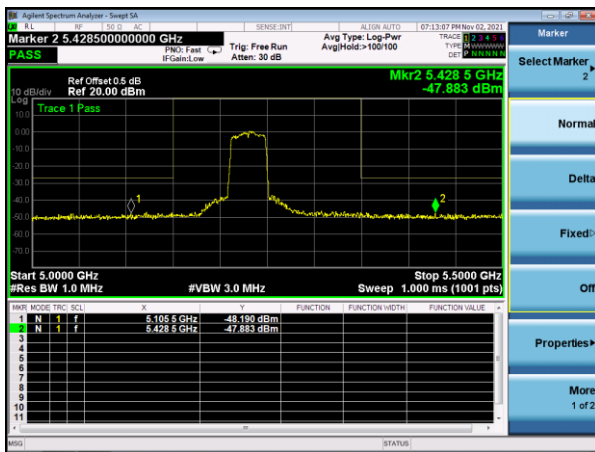

(802.11ac80) Band Edge, Right Side

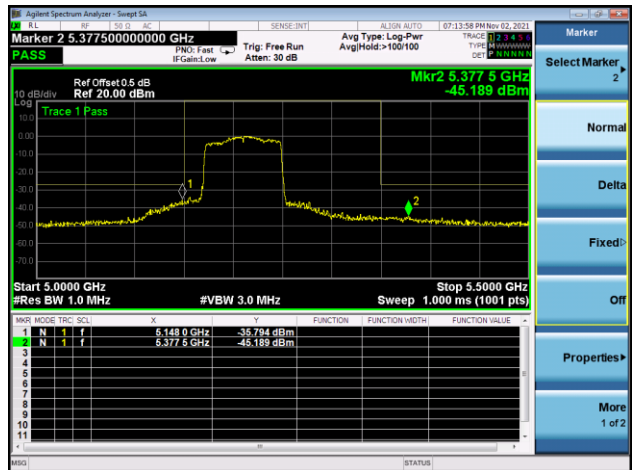

12. Spurious RF Conducted Emissions

12.1 Block Diagram Of Test Setup



12.2 Limit

Undesirable emission limits. Except as shown in paragraph (b)(7) of this section, the maximum emissions outside of the frequency bands of operation shall be attenuated in accordance with the following limits:

(1) For transmitters operating in the 5.15-5.25 GHz band: All emissions outside of the 5.15-5.35 GHz band shall not exceed an e.i.r.p. of -27 dBm/MHz.

(2) For transmitters operating in the 5.725-5.85 GHz band(i) All emissions shall be limited to a level of -27 dBm/MHz at 75 MHz or more above or below the band edge increasing linearly to 10 dBm/MHz at 25 MHz above or below the band edge, and from 25 MHz above or below the band edge increasing linearly to a level of 15.6 dBm/MHz at 5 MHz above or below the band edge, and from 5 MHz above or below the band edge increasing linearly to a level of 27 dBm/MHz at the band edge..

12.3 Test Procedure

1. Check the calibration of the measuring instrument using either an internal calibrator or a known signal from an external generator.
2. Position the EUT without connection to measurement instrument. Turn on the EUT and connect its antenna terminal to measurement instrument via a low loss cable. Then set it to any one measured frequency within its operating range, and make sure the instrument is operated in its linear range.
3. Set RBW of spectrum analyzer to 1 MHz with a convenient frequency span.
4. Measure the highest amplitude appearing on spectral display and set it as a reference level. Plot the graph with marking the highest point and edge frequency.
5. Repeat above procedures until all measured frequencies were complete.

12.4 Test Result

Remark: The measurement frequency range is from 9KHz to the 10th harmonic of the fundamental frequency. The lowest, middle and highest channels are tested to verify the spurious emissions and bandege measurement data.

About:26.5GHz-40GHz, The amplitude of spurious emissions which are attenuated by more than 20dB below the permissible value has no need to be reported.

**5.1G
Test Plot**

802.11a on channel 36



802.11a on channel 40

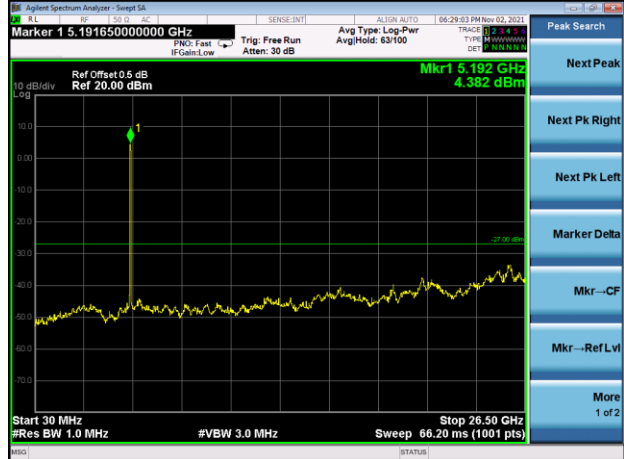

802.11a on channel 36

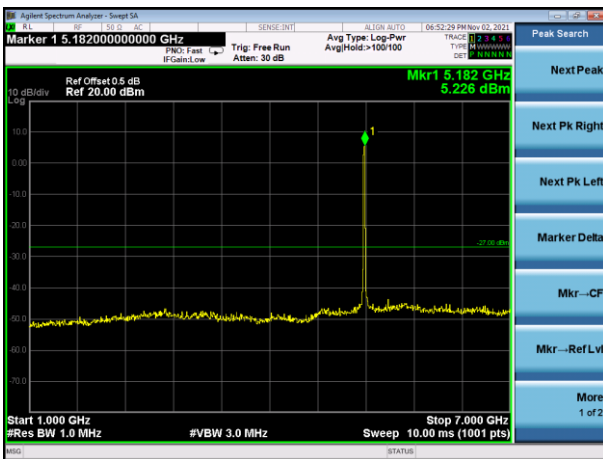

802.11a on channel 40

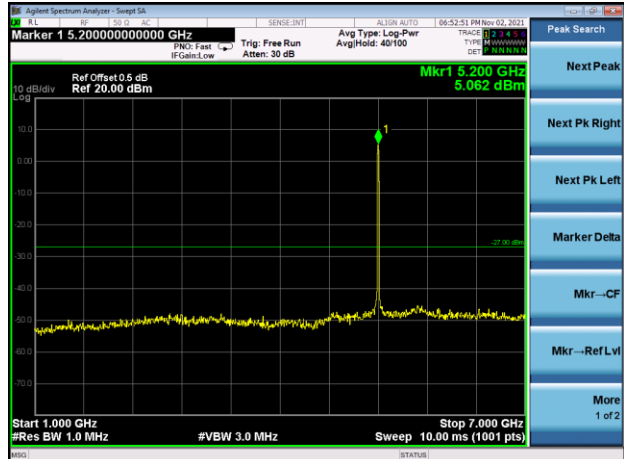

802.11a on channel 36



802.11a on channel 40



Test Plot

802.11a on channel 48



802.11n20 on channel 36

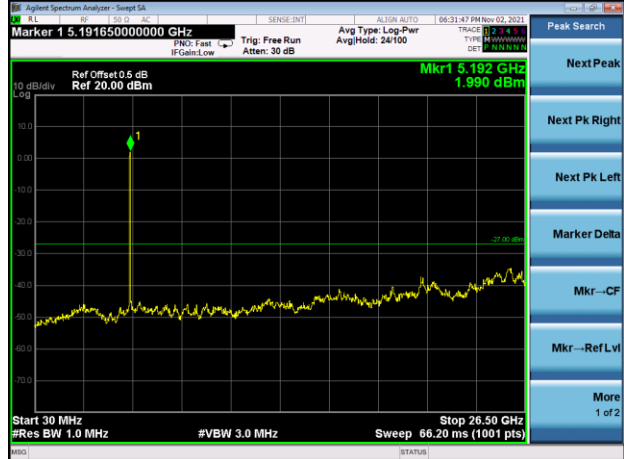

802.11a on channel 48

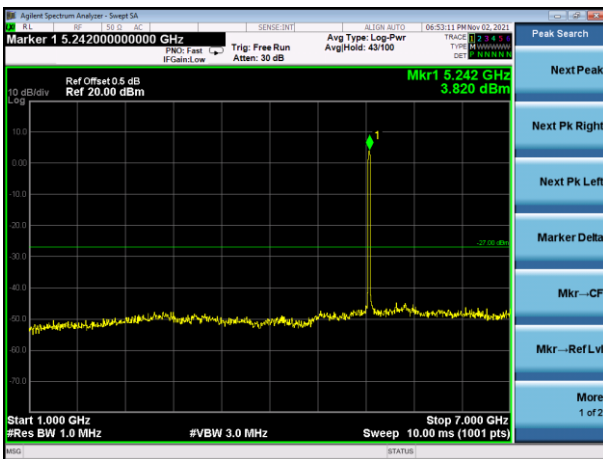

802.11n20 on channel 36

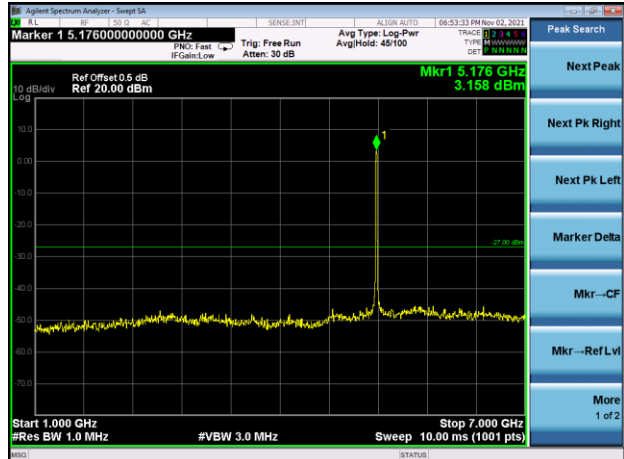

802.11a on channel 48



802.11n20 on channel 36



Test Plot

802.11n20 on channel 40

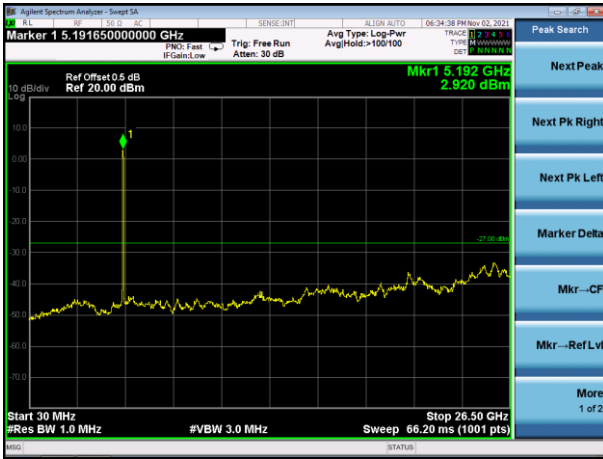

802.11n20 on channel 48



802.11n20 on channel 40

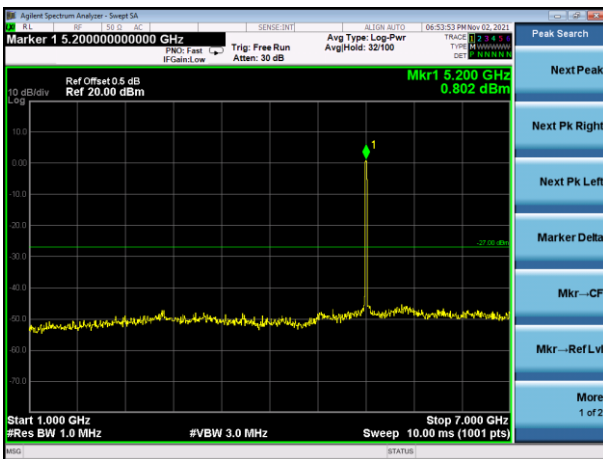

802.11n20 on channel 48

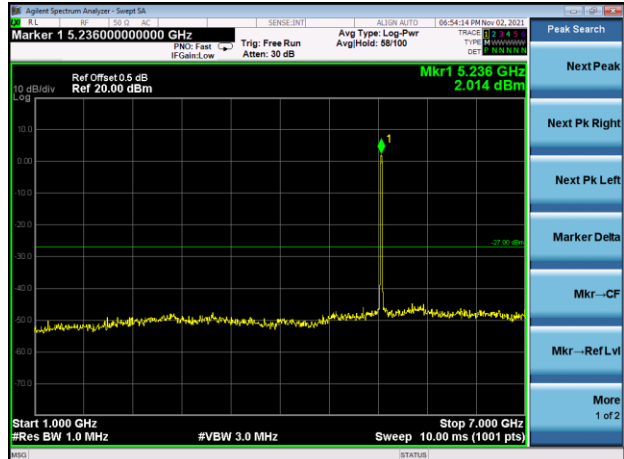

802.11n20 on channel 40



802.11n20 on channel 48



Test Plot

802.11n40 on channel 38

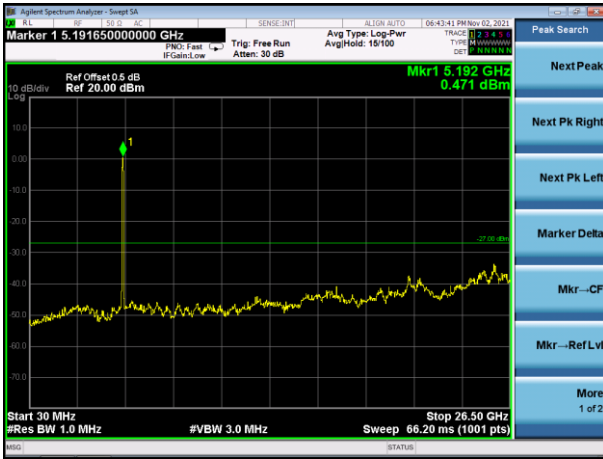

802.11n40 on channel 46



802.11n40 on channel 38

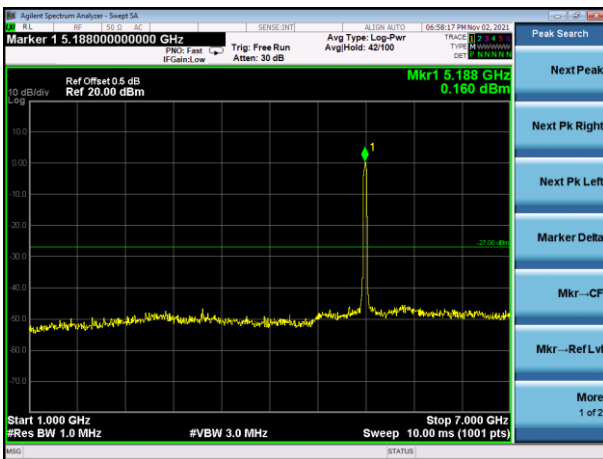

802.11n40 on channel 46

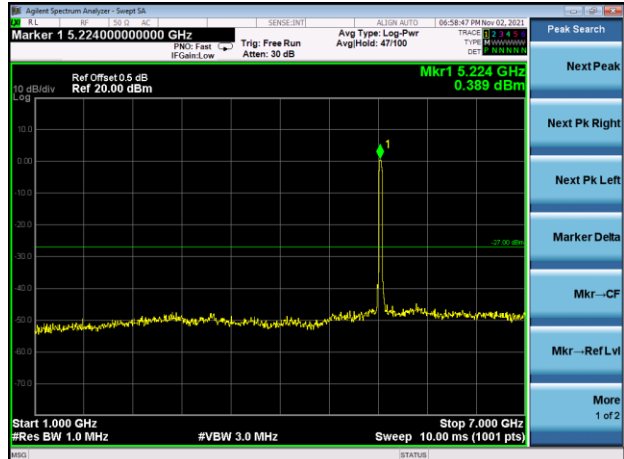

802.11n40 on channel 38



802.11n40 on channel 46



Test Plot

802.11ac20 on channel 36



802.11ac20 on channel 40



802.11ac20 on channel 36

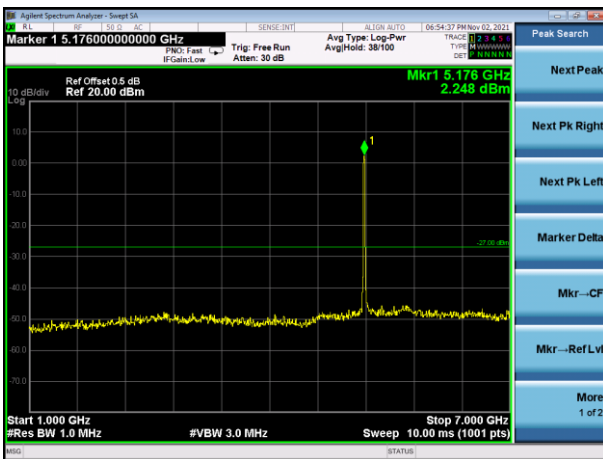

802.11ac20 on channel 40

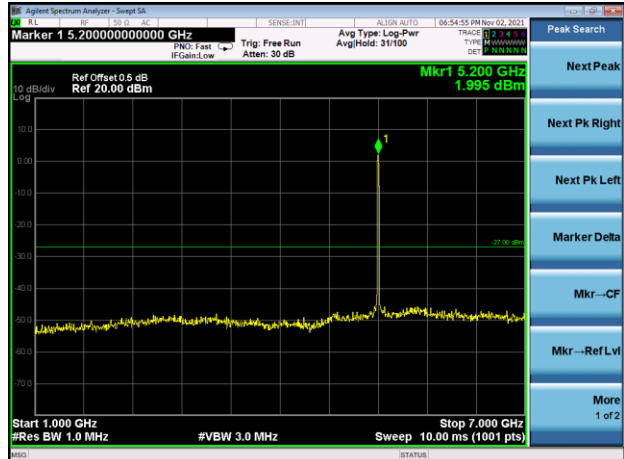

802.11ac20 on channel 36



802.11ac20 on channel 40



Test Plot

802.11ac20 on channel 48



802.11ac40 on channel 38



802.11ac20 on channel 48

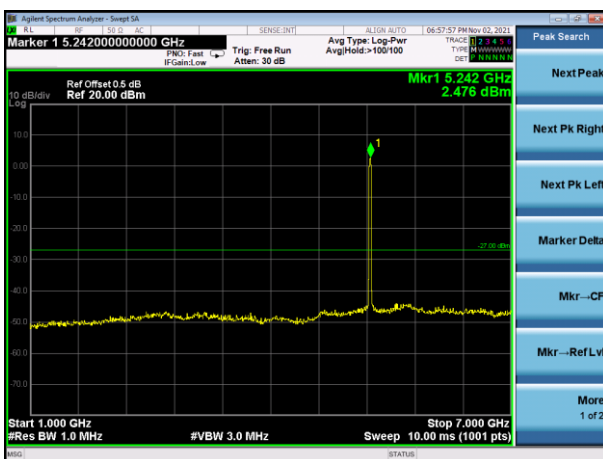

802.11ac40 on channel 38

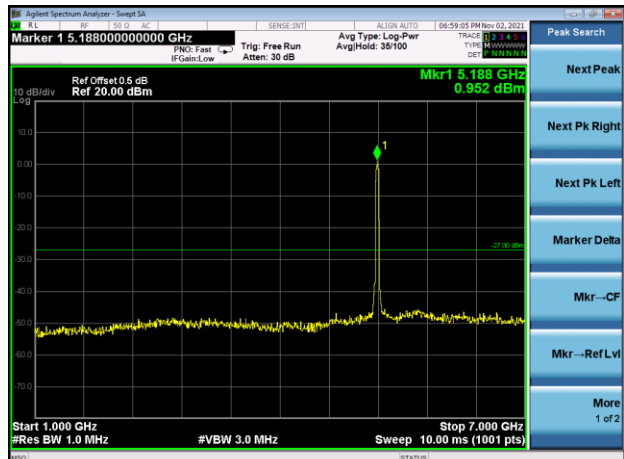

802.11ac20 on channel 48

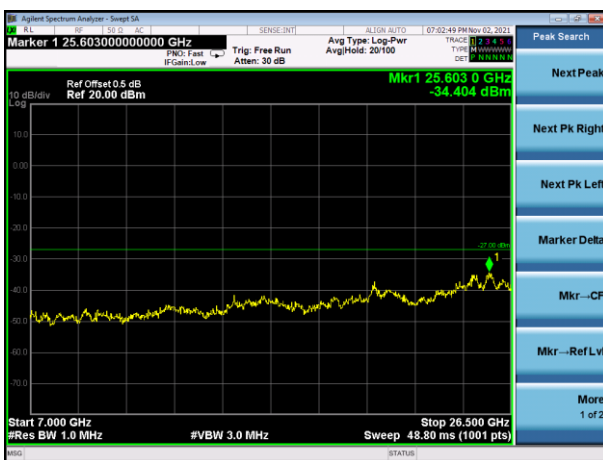

802.11ac40 on channel 38



Test Plot

802.11ac40 on channel 46



802.11ac80 on channel 42

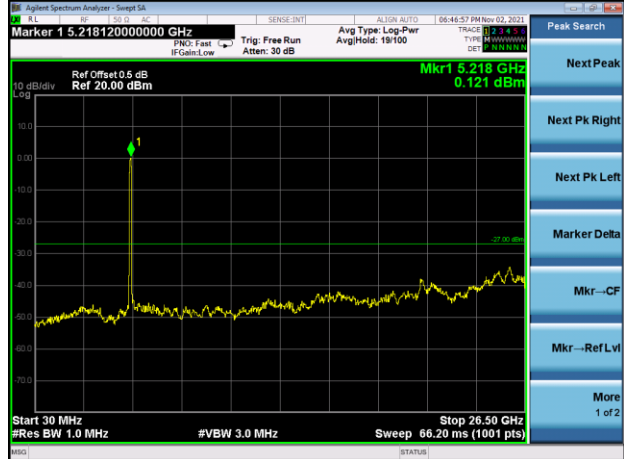

802.11 ac40 on channel 46

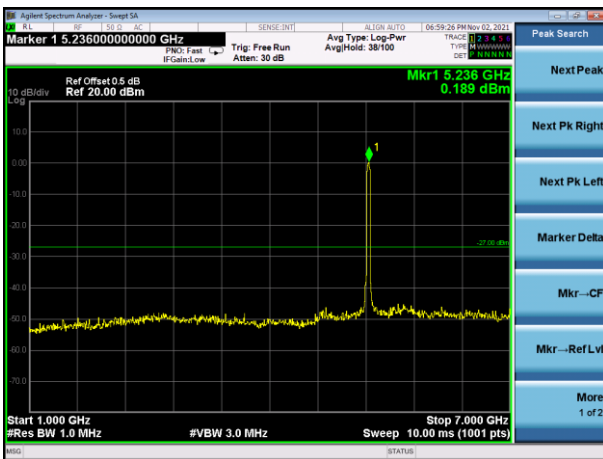

802.11 ac80 on channel 42

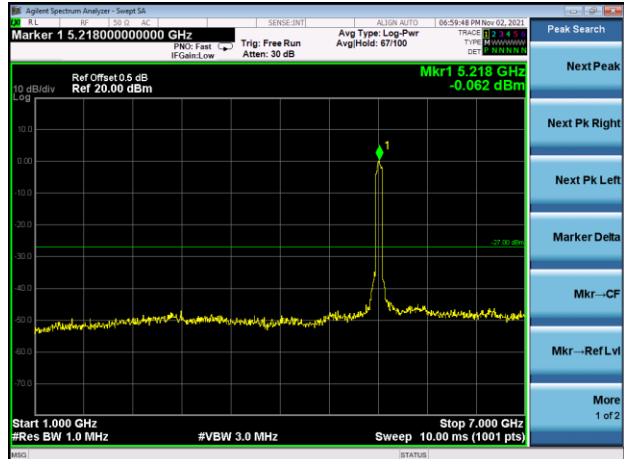

802.11 ac40 on channel 46



802.11 ac80 on channel 42



13. Frequency Stability Measurement

13.1 Block Diagram Of Test Setup

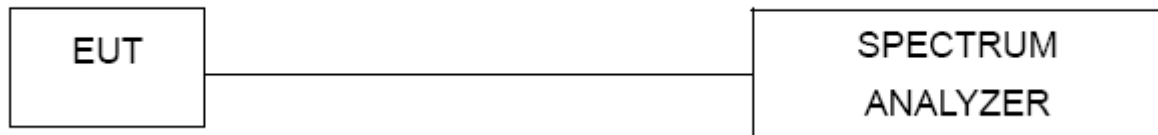

13.2 Limit

Manufactures of U-NII devices are responsible for ensuring frequency stability such that an emission is maintained within the band of operation under all conditions of normal operation as specified in the user's manual.

The transmitter center frequency tolerance shall be ± 20 ppm maximum for the 5 GHz band (IEEE 802.11n specification)..

13.3 Test Procedure

1. The transmitter output (antenna port) was connected to the spectrum analyzer.
2. EUT have transmitted absence of modulation signal and fixed channelize.
3. Set the spectrum analyzer span to view the entire absence of modulation emissions bandwidth.
4. Set RBW = 10 kHz, VBW = 10 kHz with peak detector and maxhold settings.
5. f_c is declaring of channel frequency. Then the frequency error formula is $(f_c - f) / f_c \times 10^6$ ppm and he limit is less than ± 20 ppm (IEEE 802.11n specification).
6. The test extreme voltage is to change the primary supply voltage from 85 to 115 percent of the nominal value
7. Extreme temperature is $-20^\circ\text{C} \sim 70^\circ\text{C}$.

13.4 Test Result

| | | | |
|---------------|-------------------------------------|---------------------|-------|
| Temperature : | 26 °C | Relative Humidity : | 54% |
| Pressure : | 101kPa | Test Voltage : | DC 9V |
| Test Mode : | TX Frequency U-NII-1 (5180-5240MHz) | | |

Voltage vs. Frequency Stability

| TEST CONDITIONS | | | | Reference Frequency : 5180MHz | | | |
|-----------------|----|-----------|------|-------------------------------|------|----------------------|----------------------|
| | | | | f | fc | Max. Deviation (MHz) | Max. Deviation (ppm) |
| T nom (°C) | 20 | V nom (V) | 5.00 | 5180.0037 | 5180 | 0.0037 | 0.7215 |
| | | V max (V) | 5.75 | 5180.0152 | 5180 | 0.0152 | 2.9439 |
| | | V min (V) | 4.25 | 5180.0110 | 5180 | 0.0110 | 2.1242 |
| Limits | | | | 5150-5250 MHz | | | |
| Result | | | | Complies | | | |

Temperature vs. Frequency Stability

| TEST CONDITIONS | | | | Reference Frequency: 5180MHz | | | |
|-----------------|-------|--------|-----|------------------------------|------|----------------------|----------------------|
| | | | | f | fc | Max. Deviation (MHz) | Max. Deviation (ppm) |
| V nom (V) | DC 5V | T (°C) | -20 | 5180.0126 | 5180 | 0.0126 | 2.4323 |
| | | T (°C) | -10 | 5180.0025 | 5180 | 0.0025 | 0.4818 |
| | | T (°C) | 0 | 5180.0114 | 5180 | 0.0114 | 2.2006 |
| | | T (°C) | 10 | 5180.0085 | 5180 | 0.0085 | 1.6439 |
| | | T (°C) | 20 | 5180.0093 | 5180 | 0.0093 | 1.7952 |
| | | T (°C) | 30 | 5180.0077 | 5180 | 0.0077 | 1.4807 |
| | | T (°C) | 40 | 5180.0026 | 5180 | 0.0026 | 0.5075 |
| | | T (°C) | 50 | 5180.0088 | 5180 | 0.0088 | 1.7037 |
| | | T (°C) | 60 | 5180.0131 | 5180 | 0.0131 | 2.5225 |
| | | T (°C) | 70 | 5180.0055 | 5180 | 0.0055 | 1.0522 |
| Limits | | | | 5150-5250 MHz | | | |
| Result | | | | Complies | | | |

Voltage vs. Frequency Stability

| TEST CONDITIONS | | | | Reference Frequency: 5200MHz | | | |
|-----------------|----|-----------|------|------------------------------|------|----------------------|----------------------|
| | | | | f | fc | Max. Deviation (MHz) | Max. Deviation (ppm) |
| T nom (°C) | 20 | V nom (V) | 5.00 | 5200.0065 | 5200 | 0.0065 | 1.2548 |
| | | V max (V) | 5.75 | 5200.0073 | 5200 | 0.0073 | 1.3958 |
| | | V min (V) | 4.25 | 5200.0134 | 5200 | 0.0134 | 2.5817 |
| Limits | | | | 5725-5850 MHz | | | |
| Result | | | | Complies | | | |

Temperature vs. Frequency Stability

| TEST CONDITIONS | | | | Reference Frequency: 5200MHz | | | |
|-----------------|-------|--------|-----|------------------------------|------|----------------------|----------------------|
| | | | | f | fc | Max. Deviation (MHz) | Max. Deviation (ppm) |
| V nom (V) | DC 5V | T (°C) | -20 | 5200.00924 | 5200 | 0.00924 | 1.7778 |
| | | T (°C) | -10 | 5200.00333 | 5200 | 0.00333 | 0.6404 |
| | | T (°C) | 0 | 5200.00561 | 5200 | 0.00561 | 1.0787 |
| | | T (°C) | 10 | 5200.00367 | 5200 | 0.00367 | 0.7048 |
| | | T (°C) | 20 | 5200.00824 | 5200 | 0.00824 | 1.5853 |
| | | T (°C) | 30 | 5200.00638 | 5200 | 0.00638 | 1.2267 |
| | | T (°C) | 40 | 5200.01041 | 5200 | 0.01041 | 2.0027 |
| | | T (°C) | 50 | 5200.01203 | 5200 | 0.01203 | 2.3140 |
| | | T (°C) | 60 | 5200.00527 | 5200 | 0.00527 | 1.0142 |
| | | T (°C) | 70 | 5200.01125 | 5200 | 0.01125 | 2.1636 |
| Limits | | | | 5150-5250 MHz | | | |
| Result | | | | Complies | | | |

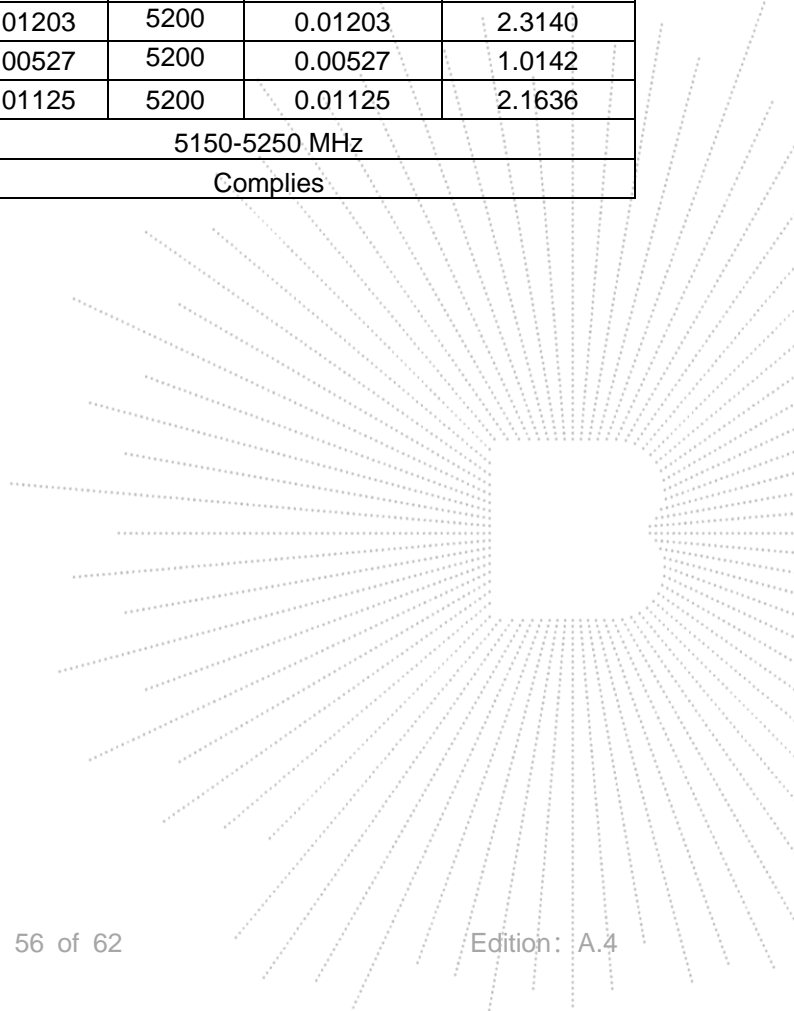

Voltage vs. Frequency Stability

| TEST CONDITIONS | | | | Reference Frequency: 5240MHz | | | |
|-----------------|----|-----------|------|------------------------------|------|----------------------|----------------------|
| | | | | f | fc | Max. Deviation (MHz) | Max. Deviation (ppm) |
| T nom (°C) | 20 | V nom (V) | 5.00 | 5240.0028 | 5240 | 0.0028 | 0.5345 |
| | | V max (V) | 5.75 | 5240.0047 | 5240 | 0.0047 | 0.8890 |
| | | V min (V) | 4.25 | 5240.0066 | 5240 | 0.0066 | 1.2600 |
| Limits | | | | 5150-5250 MHz | | | |
| Result | | | | Complies | | | |

Temperature vs. Frequency Stability

| TEST CONDITIONS | | | | Reference Frequency: 5240MHz | | | |
|-----------------|-------|--------|-----|------------------------------|------|----------------------|----------------------|
| | | | | f | fc | Max. Deviation (MHz) | Max. Deviation (ppm) |
| V nom (V) | DC 5V | T (°C) | -20 | 5240.0022 | 5240 | 0.0022 | 0.4155 |
| | | T (°C) | -10 | 5240.0114 | 5240 | 0.0114 | 2.1764 |
| | | T (°C) | 0 | 5240.0009 | 5240 | 0.0009 | 0.1811 |
| | | T (°C) | 10 | 5240.0076 | 5240 | 0.0076 | 1.4421 |
| | | T (°C) | 20 | 5240.0007 | 5240 | 0.0007 | 0.1317 |
| | | T (°C) | 30 | 5240.0090 | 5240 | 0.0090 | 1.7087 |
| | | T (°C) | 40 | 5240.0094 | 5240 | 0.0094 | 1.7901 |
| | | T (°C) | 50 | 5240.0035 | 5240 | 0.0035 | 0.6727 |
| | | T (°C) | 60 | 5240.0001 | 5240 | 0.0001 | 0.0111 |
| | | T (°C) | 70 | 5240.0097 | 5240 | 0.0097 | 1.8466 |
| Limits | | | | 5150-5250 MHz | | | |
| Result | | | | Complies | | | |

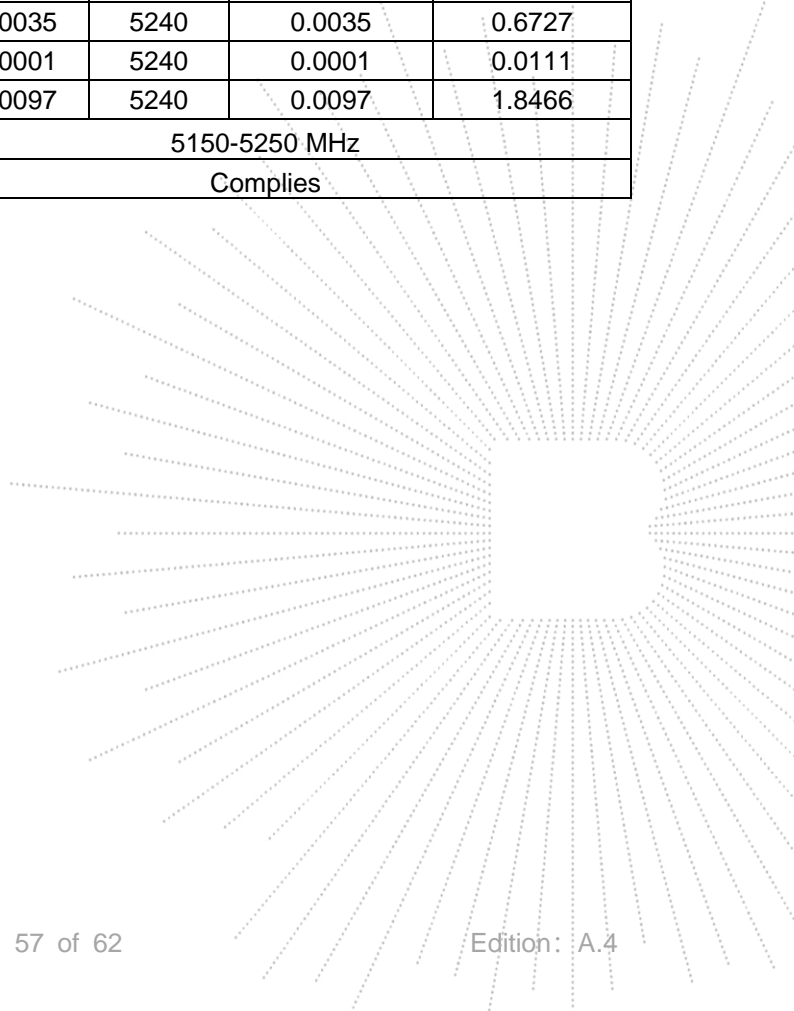

14. Antenna Requirement

14.1 Limit

15.203 requirement: For intentional device, according to 15.203: an intentional radiator shall be designed to ensure that no antenna other than that furnished by the responsible party shall be used with the device.

14.2 EUT Antenna

The EUT antenna is Chip Antenna (antenna gain:2dBi). It comply with the standard requirement.

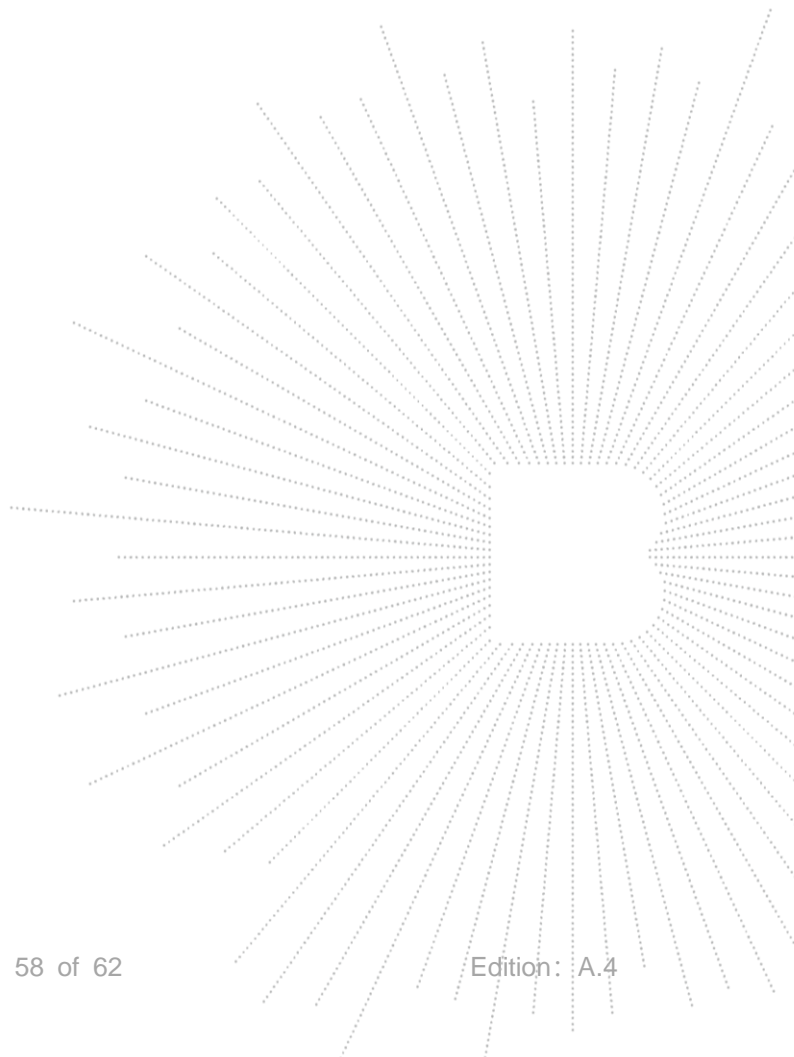

15. EUT Photographs

EUT Photo 1

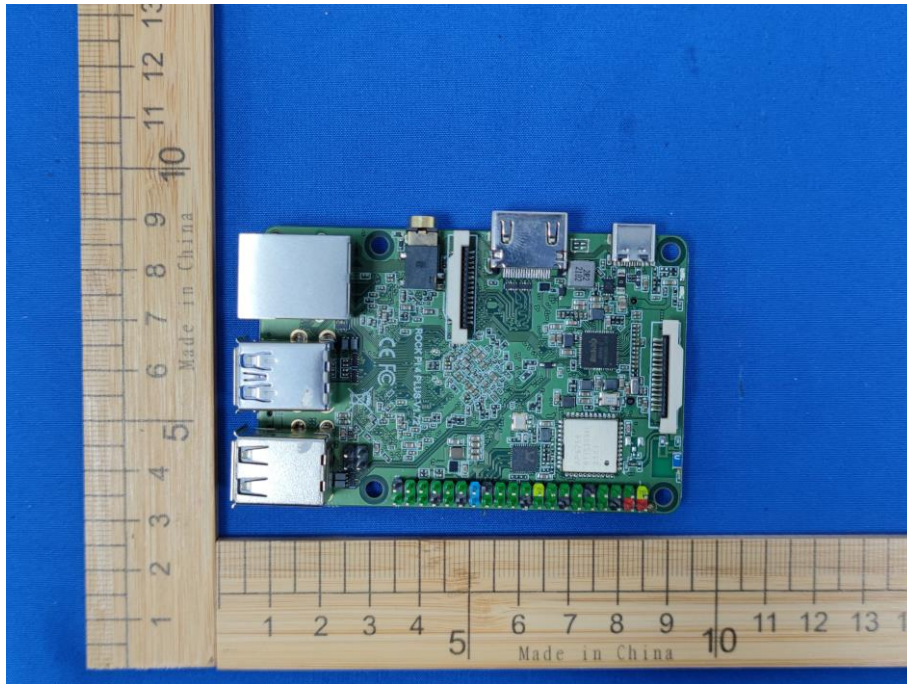

EUT Photo 2

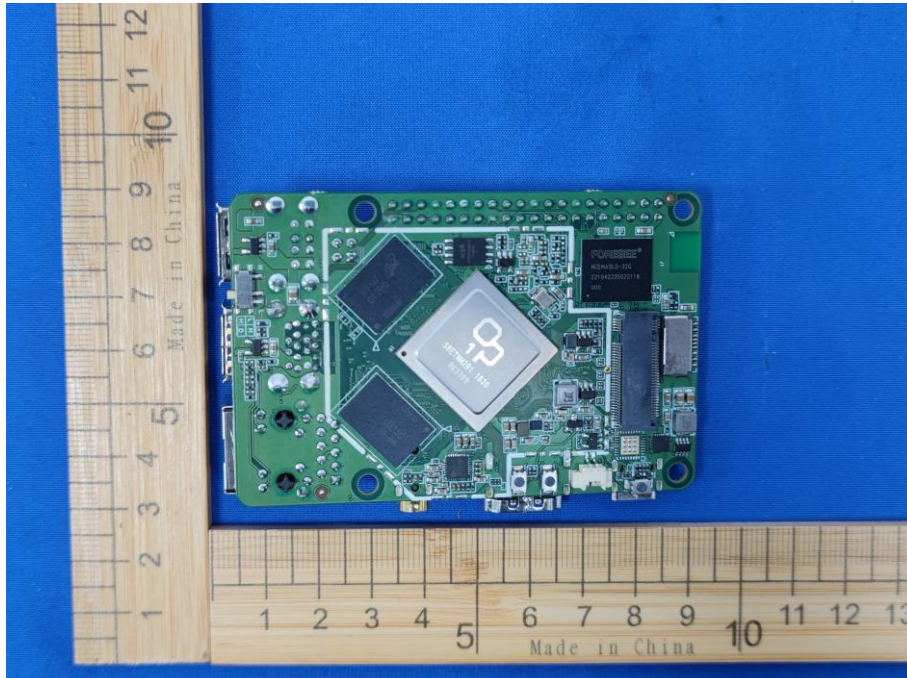

16. EUT Test Setup Photographs

Conducted Measurement Photos



Radiated Measurement Photos

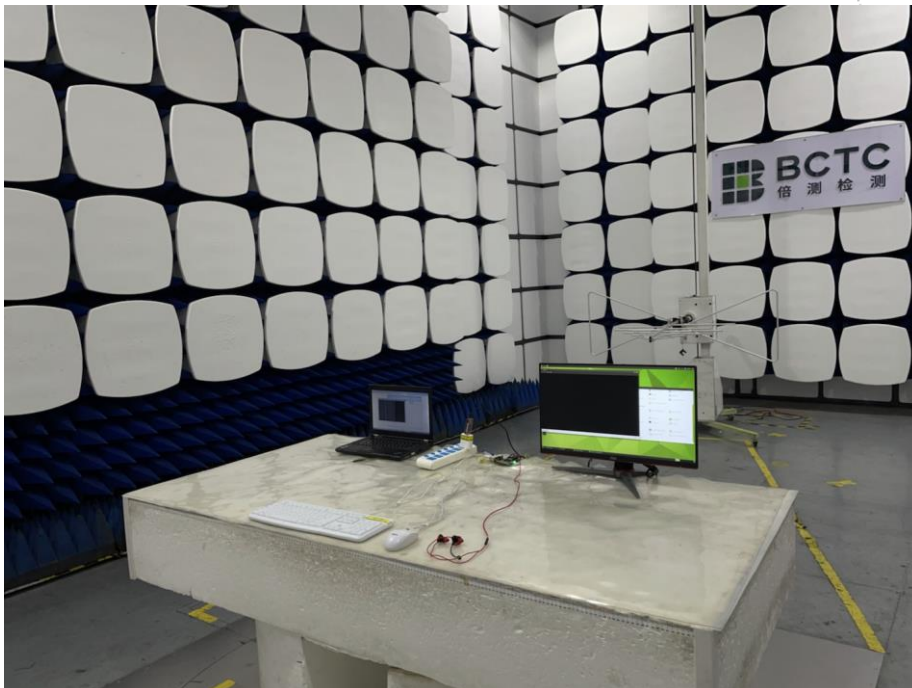

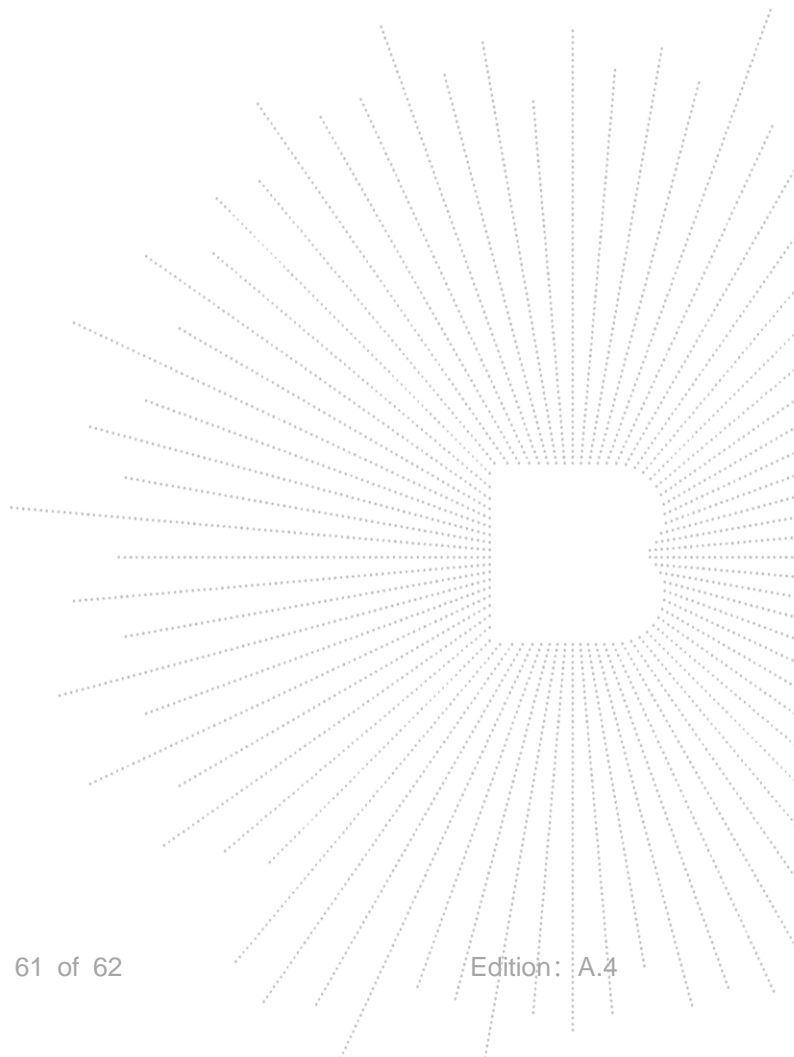
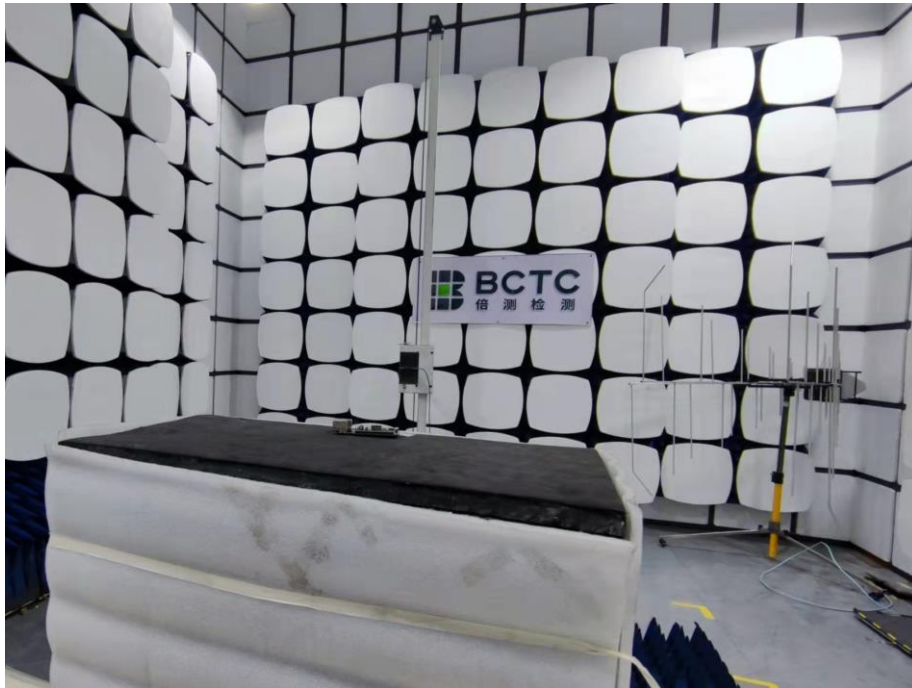

STATEMENT

- 1.The equipment lists are traceable to the national reference standards.
- 2.The test report can not be partially copied unless prior written approval is issued from our lab.
- 3.The test report is invalid without stamp of laboratory.
- 4.The test report is invalid without signature of person(s) testing and authorizing.
- 5.The test process and test result is only related to the Unit Under Test.
- 6.The quality system of our laboratory is in accordance with ISO/IEC17025.
- 7.If there is any objection to report, the client should inform issuing laboratory within 15 days from the date of receiving test report.

Address:

1-2/F., Building B, Pengzhou Industrial Park, No.158, Fuyuan 1st Road, Tangwei, Fuhai Subdistrict, Bao'an District, Shenzhen, Guangdong, China

TEL: 400-788-9558

P.C.: 518103

FAX: 0755-33229357

Website: <http://www.chnbctc.com>

E-Mail: bctc@bctc-lab.com.cn

***** END *****

