

# TEST REPORT

Report No.: BCTC2206634854-4E

---

Applicant: ROCKPI TRADING LIMITED

---

Product Name: ROCK Pi 4/ROCK 4

---

Model/Type Ref.: ROCK 4 SE

---

Tested Date: 2022-06-30 to 2022-07-05

---

Issued Date: 2022-07-05

---

Shenzhen **BCTC** Testing Co., Ltd.

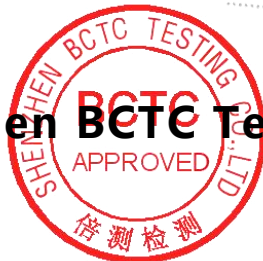

# FCC ID: 2A3PA-ROCK4SE

Product Name: ROCK Pi 4  
Trademark: N/A  
Model/Type Ref.: ROCK 4 SE  
ROCK Pi 4 A, ROCK Pi 4 B, ROCK Pi 4 A+, ROCK Pi 4 B+, ROCK 4 SE,  
ROCK 4 A, ROCK 4 B, ROCK 4 A+, ROCK 4 B+  
Prepared For: ROCKPI TRADING LIMITED  
Address: Room 11, 27 / f, Ga wah international centre, 191 Javaroad, north point, Hong Kong  
Manufacturer: ROCKPI TRADING LIMITED  
Address: Room 11, 27 / f, Ga wah international centre, 191 Javaroad, north point, Hong Kong  
Prepared By: Shenzhen BCTC Testing Co., Ltd.  
Address: 1-2/F., Building B, Pengzhou Industrial Park, No.158, Fuyuan 1st Road, Tangwei,  
Fuhai Subdistrict, Bao'an District, Shenzhen, Guangdong, China  
Sample Received Date: 2022-06-30  
Sample tested Date: 2022-06-30 to 2022-07-05  
Issue Date: 2022-07-05  
Report No.: BCTC2206634854-4E  
FCC Part15 15.407  
Test Standards ANSI C63.10-2013  
KDB 662911 D01 v02r01  
KDB 789033 D02 v02r01  
Test Results PASS

Tested by:



Brave Zeng/ Project Handler

Approved by:



Zero Zhou/Reviewer

The test report is effective only with both signature and specialized stamp. This result(s) shown in this report refer only to the sample(s) tested. Without written approval of Shenzhen BCTC Testing Co., Ltd, this report can't be reproduced except in full. The tested sample(s) and the sample information are provided by the client.

## Table Of Content

Test Report Declaration	Page
1. Version .....	5
2. Test Summary .....	6
3. Measurement Uncertainty .....	7
4. Product Information And Test Setup .....	8
4.1 Product Information.....	8
4.2 Test Setup Configuration .....	8
4.3 Support Equipment .....	9
4.4 Channel List.....	9
4.5 Test Mode.....	10
4.6 Table Of Parameters Of Text Software Setting.....	10
5. Test Facility And Test Instrument Used.....	11
5.1 Test Facility.....	11
5.2 Test Instrument Used.....	11
6. Conducted Emissions.....	13
6.1 Block Diagram Of Test Setup.....	13
6.2 Limit .....	13
6.3 Test Procedure .....	13
6.4 EUT Operating Conditions .....	13
6.5 Test Result.....	14
7. Radiated Emissions.....	16
7.1 Block Diagram Of Test Setup.....	16
7.2 Limit .....	17
7.3 Test Procedure .....	18
7.4 EUT Operating Conditions .....	19
7.5 Test Result.....	19
8. Power Spectral Density Test .....	28
8.1 Block Diagram Of Test Setup.....	28
8.2 Limit .....	28
8.3 Test Procedure .....	29
8.4 EUT Operating Conditions .....	29
8.5 Test Result.....	30
9. 26dB & 99% Emission Bandwidth .....	38
9.1 Block Diagram Of Test Setup.....	38
9.2 Limit .....	38
9.3 Test Procedure .....	38
9.4 EUT Operating Conditions .....	39
9.5 Test Result.....	39
10. Maximum Conducted Output Power.....	54
10.1 Block Diagram Of Test Setup.....	54
10.2 Limit .....	54
10.3 Test Procedure .....	54
10.4 EUT Operating Conditions .....	55
10.5 Test Result.....	56

11. Out Of Band Emissions .....	57
11.1 Block Diagram Of Test Setup.....	57
11.2 Limit .....	57
11.3 Test Procedure .....	57
11.4 EUT Operating Conditions .....	57
11.5 Test Result.....	58
12. Spurious RF Conducted Emissions.....	65
12.1 Block Diagram Of Test Setup.....	65
12.2 Limit .....	65
12.3 Test Procedure .....	65
12.4 Test Result.....	65
13. Frequency Stability Measurement.....	73
13.1 Block Diagram Of Test Setup.....	73
13.2 Limit .....	73
13.3 Test Procedure .....	73
13.4 Test Result.....	74
14. Antenna Requirement .....	77
14.1 Limit .....	77
14.2 Test Result.....	77
15. EUT Photographs.....	78
16. EUT Test Setup Photographs.....	79

(Note: N/A Means Not Applicable)

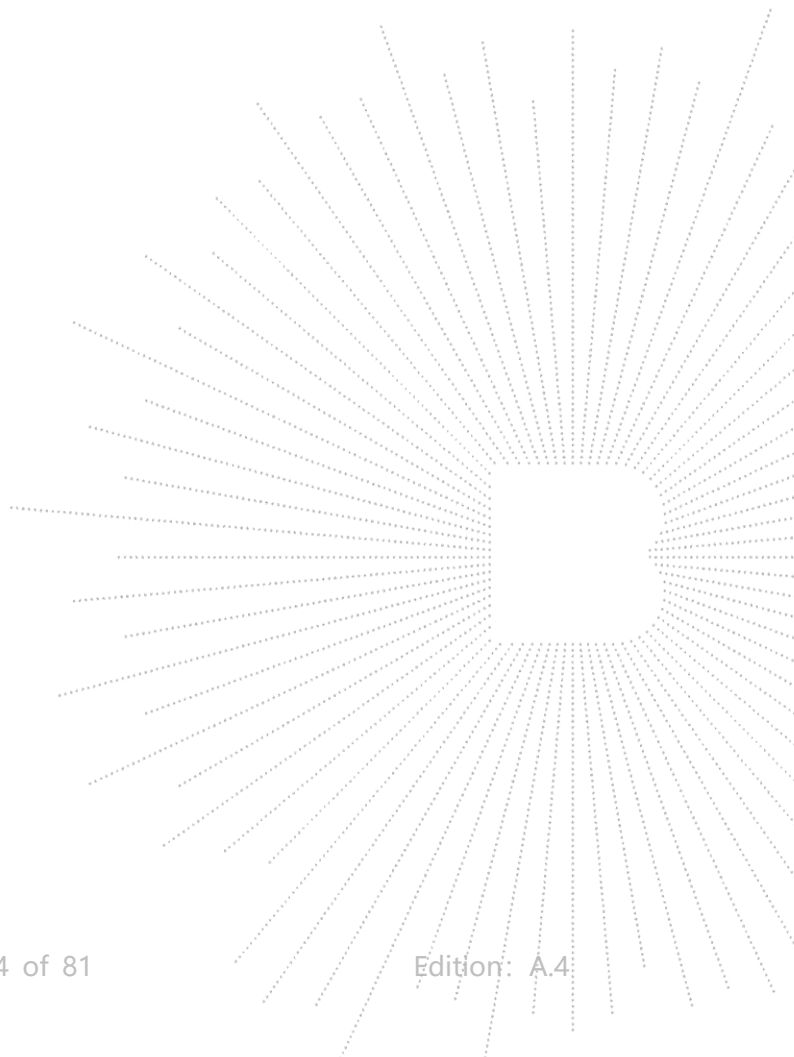

**1. Version**

<b>Report No.</b>	<b>Issue Date</b>	<b>Description</b>	<b>Approved</b>
BCTC2206634854-4E	2022-07-05	Original	Valid

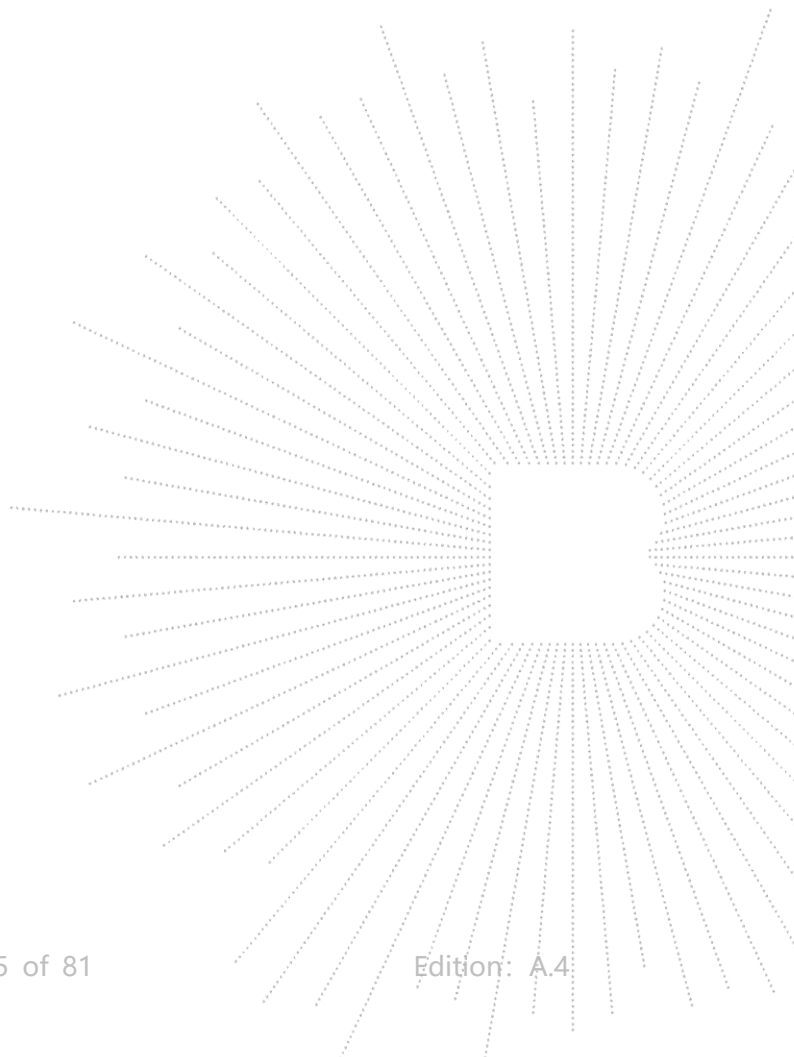

## 2. Test Summary

The Product has been tested according to the following specifications:

No.	Test Parameter	Clause No	Results
1	Spurious Radiated Emissions	15.209(a), 15.407 (b)(1) 15.407 (b)(4) 15.407 (b)(6)	PASS
2	Conducted Emission	15.207	N/A
3	26 dB and 99% Emission Bandwidth	15.407 (a)(5) 15.1049	PASS
4	Minimum 6 dB bandwidth	15.407(e)	PASS
5	Maximum Conducted Output Power	15.407 (a)(1) 15.407 (a)(3)	PASS
6	Band Edge	2.1051, 15.407(b)(1) 15.407(b)(4)	PASS
7	Power Spectral Density	15.407 (a)(1) 15.407 (a)(3)	PASS
8	Spurious Emissions at Antenna Terminals	2.1051, 15.407(b)	PASS
9	Antenna Requirement	15.203	PASS

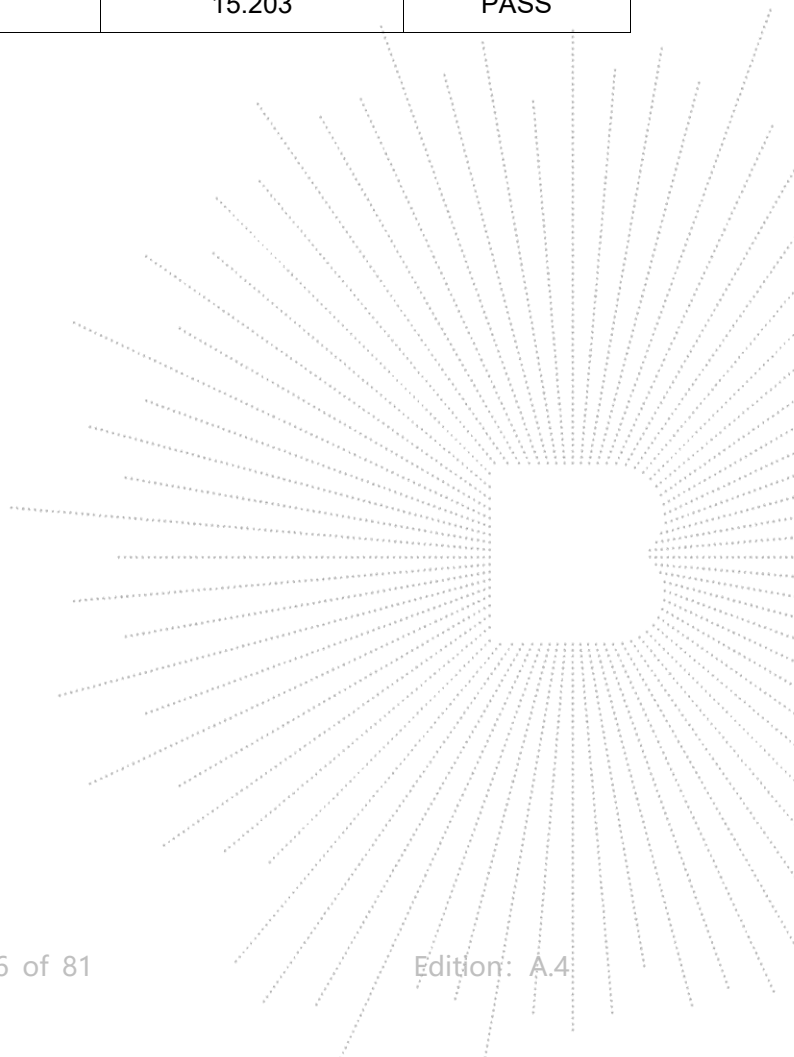

### 3. Measurement Uncertainty

Where relevant, the following measurement uncertainty levels have been estimated for tests performed on the Product as specified in CISPR 16-4-2. This uncertainty represents an expanded uncertainty expressed at approximately the 95% confidence level using a coverage factor of  $k=2$ .

No.	Item	Uncertainty
1	3m chamber Radiated spurious emission(9kHz-30MHz)	U=3.7dB
2	3m chamber Radiated spurious emission(30MHz-1GHz)	U=4.3dB
3	3m chamber Radiated spurious emission(1GHz-18GHz)	U=4.5dB
4	3m chamber Radiated spurious emission(18GHz-40GHz)	U=3.34dB
5	Conducted Emission(150kHz-30MHz)	U=3.20dB
6	Conducted Adjacent channel power	U=1.38dB
7	Conducted output power uncertainty Above 1G	U=1.576dB
8	Conducted output power uncertainty below 1G	U=1.28dB
9	humidity uncertainty	U=5.3%
10	Temperature uncertainty	U=0.59°C

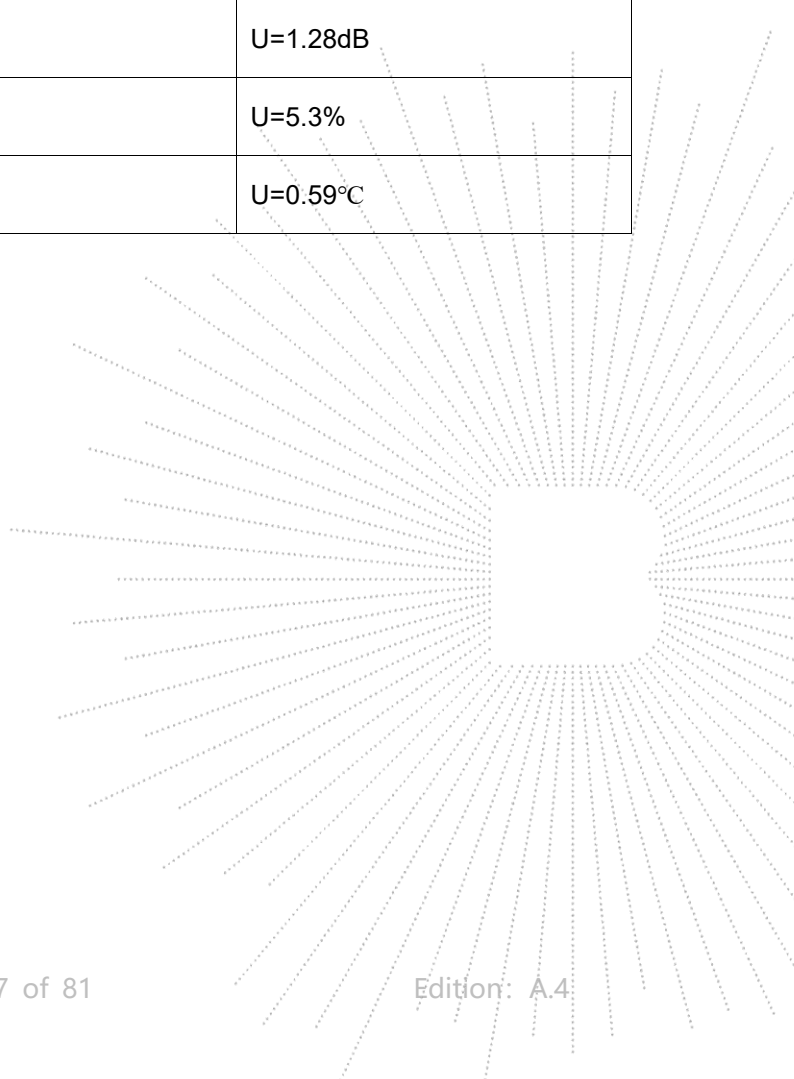

## 4. Product Information And Test Setup

### 4.1 Product Information

Model/Type Ref.:	ROCK 4 SE ROCK Pi 4 A, ROCK Pi 4 B, ROCK Pi 4 A+, ROCK Pi 4 B+, ROCK 4 SE, ROCK 4 A, ROCK 4 B, ROCK 4 A+, ROCK 4 B+
Model differences:	All the model are the same circuit and RF module, except model names.
Hardware Version:	N/A
Software Version:	N/A
IEEE 802.11 WLAN	802.11a/n/ac(20MHz channel bandwidth) 802.11n/ac(40MHz channel bandwidth)
Mode Supported	802.11ac(80MHz channel bandwidth)
Operation Frequency:	5180-5240MHz for 802.11a/n/ac(HT20); 5190-5230MHz for 802.11n/ac(HT40); 5210MHz for 802.11 ac80;
Data Rate	802.11a: 6,9,12,18,24,36,48,54Mbps; 802.11n(HT20/HT40):MCS0-MCS15; 802.11ac(VHT20): NSS1, MCS0-MCS8 802.11ac(VHT40/VHT80):NSS1, MCS0-MCS
Type of Modulation:	OFDM with BPSK/QPSK/16QAM/64QAM/256QAM for 802.11a/n/ac;
Number Of Channel	4 channels for 802.11a/n20 in the 5180-5240MHz band ; 2 channels for 802.11 n40 in the 5190-5230MHz band ; 1 channels for 802.11 ac80 in the 5210MHz band ;
Antenna installation:	Chip antenna
Antenna Gain:	2 dBi
Ratings:	DC 5V From adapter

### 4.2 Test Setup Configuration

See test photographs attached in *EUT TEST SETUP PHOTOGRAPHS* for the actual connections between Product and support equipment.

Conducted Emission:

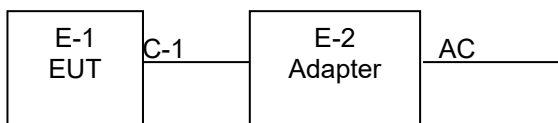

Radiated Spurious Emission

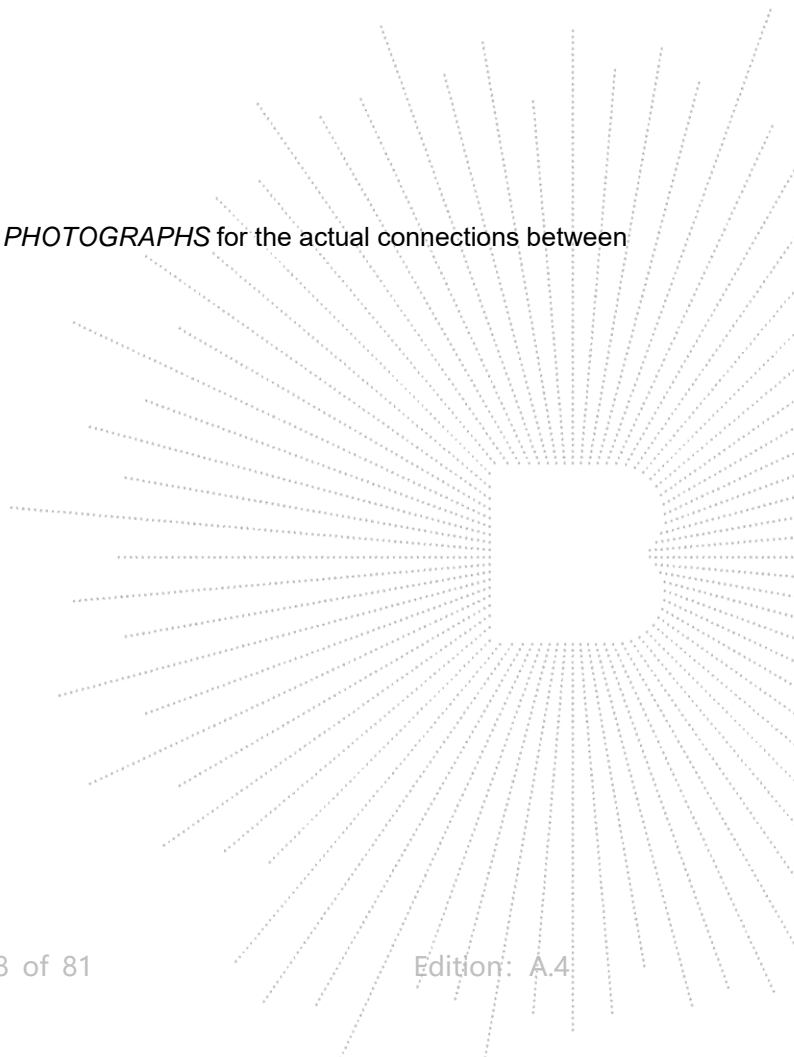
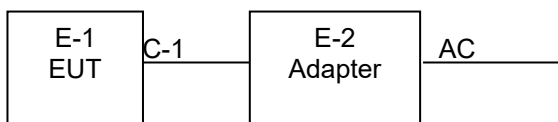



### 4.3 Support Equipment

No.	Device Type	Brand	Model	Series No.	Note
E-1	ROCK Pi 4/ROCK 4	N/A	ROCK 4 SE	N/A	EUT
E-2	Adapter	N/A	BCTC001	N/A	Auxiliary

Item	Shielded Type	Ferrite Core	Length	Note
C-1	N/A	N/A	0.3M	DC cable unshielded

**Notes:**

1. All the equipment/cables were placed in the worst-case configuration to maximize the emission during the test.
2. Grounding was established in accordance with the manufacturer's requirements and conditions for the intended use.

### 4.4 Channel List

802.11a/n/ac( 20MHz) Carrier Frequency Channel							
Channel	Frequency (MHz)	Channel	Frequency (MHz)	Channel	Frequency (MHz)	Channel	Frequency (MHz)
36	5180	44	5220	40	5200	48	5240
149	5745	153	5765	157	5785	161	5805
165	5825	-	-	-	-	-	-

802.11n/ac (40MHz) Carrier Frequency Channel							
Channel	Frequency (MHz)	Channel	Frequency (MHz)	Channel	Frequency (MHz)	Channel	Frequency (MHz)
38	5190	46	5230	-	-	-	-
151	5755	159	5795	-	-	-	-

802.11ac (80MHz) Carrier Frequency Channel	
Channel	Frequency (MHz)
42	5210

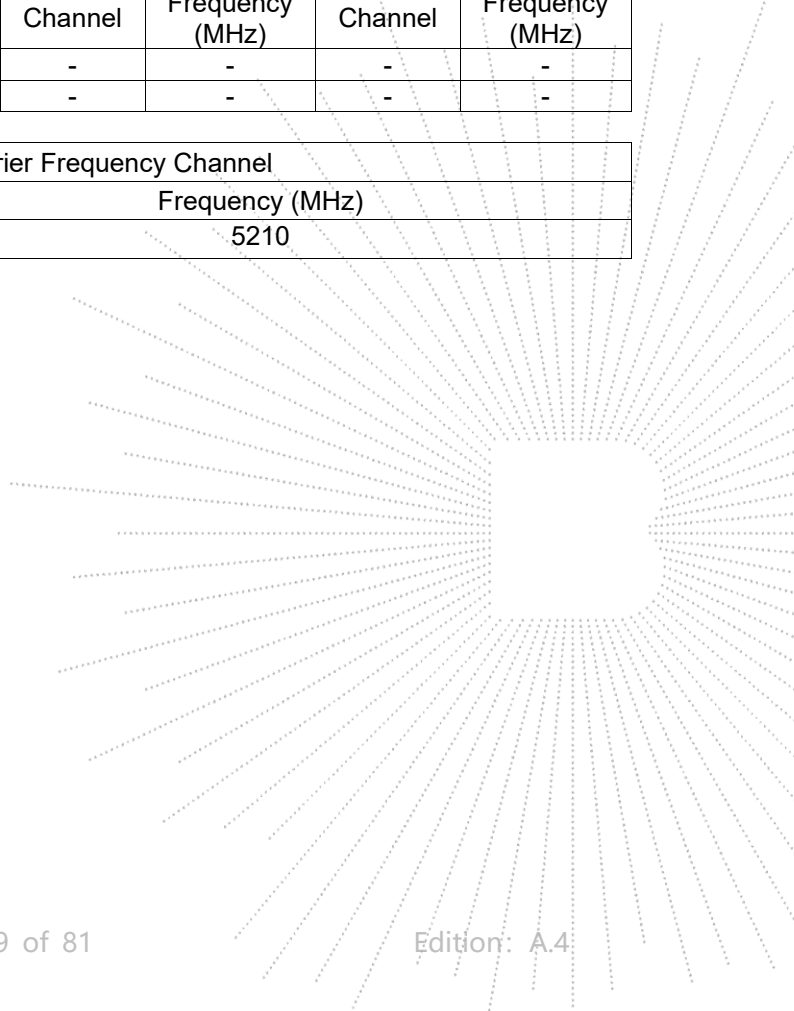

#### 4.5 Test Mode

To investigate the maximum EMI emission characteristics generates from EUT, the test system was pre-scanning tested base on the consideration of following EUT operation mode or test configuration mode which possible have effect on EMI emission level. Each of these EUT operation mode(s) or test configuration mode(s) mentioned above was evaluated respectively.

Pretest Mode	Description
Mode 1	802.11a / n/ ac 20 CH36/ CH40/ CH 48
Mode 2	802.11n/ ac40 CH38/ CH 46
Mode 3	802.11 ac80 CH 42
Mode 4	Link Mode

For Radiated Emission	
Final Test Mode	Description
Mode 1	802.11a / n/ ac 20 CH36/ CH40/ CH 48
Mode 2	802.11n/ ac40 CH38/ CH 46
Mode 3	802.11 ac80 CH 42/
Mode 4	802.11a / n/ ac 20 CH36/ CH40/ CH 48
Note:	
(1) The measurements are performed at all Bit Rate of Transmitter, the worst data was reported.	

#### 4.6 Table Of Parameters Of Text Software Setting

During testing channel & power controlling software provided by the customer was used to control the operating channel as well as the output power level. The RF output power selection is for the setting of RF output power expected by the customer and is going to be fixed on the firmware of the final end product power parameters

Test software Version	CMD		
Parameters	DEF	DEF	DEF

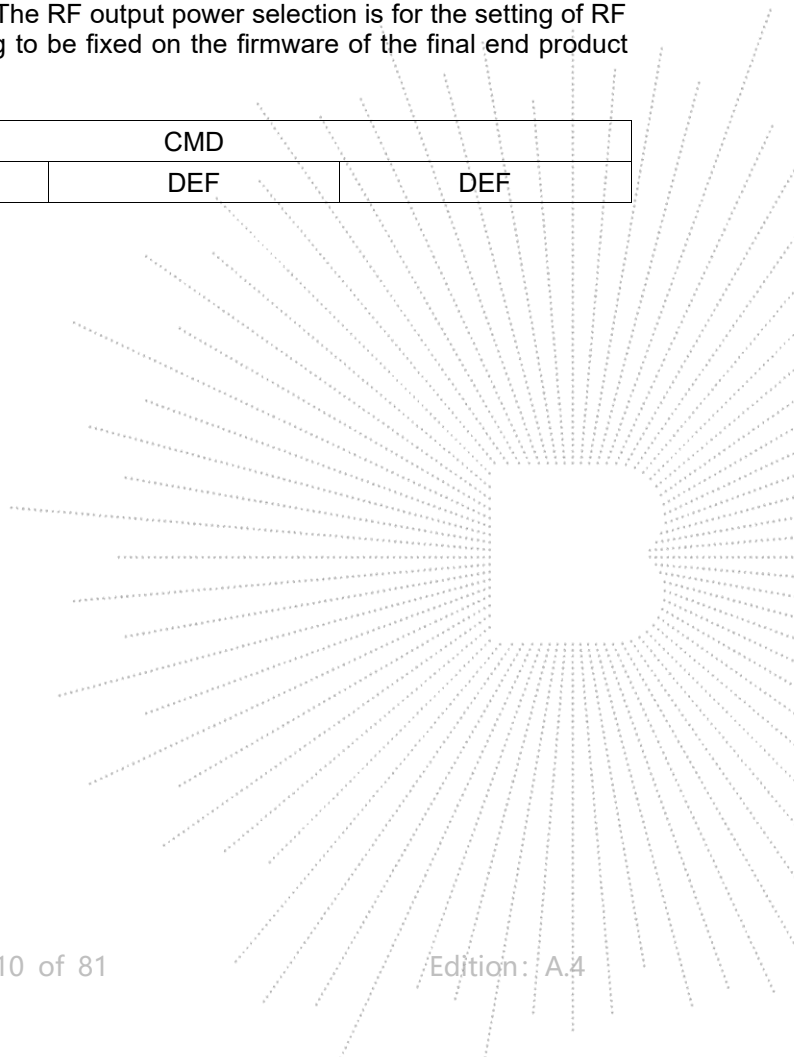

## 5. Test Facility And Test Instrument Used

### 5.1 Test Facility

All measurement facilities used to collect the measurement data are located at Shenzhen BCTC Testing Co., Ltd. Address:1-2/F., Building B, Pengzhou Industrial Park, No.158, Fuyuan 1st Road, Tangwei, Fuhai Subdistrict, Bao'an District, Shenzhen, Guangdong, China. The site and apparatus are constructed in conformance with the requirements of ANSI C63.4 and CISPR 16-1-1 other equivalent standards.

FCC Test Firm Registration Number: 712850

IC Registered No.: 23583

### 5.2 Test Instrument Used

Conducted Emissions Test					
Equipment	Manufacturer	Model#	Serial#	Last Cal.	Next Cal.
Receiver	R&S	ESR3	102075	May 24, 2022	May 23, 2023
LISN	R&S	ENV216	101375	May 24, 2022	May 23, 2023
Software	Frad	EZ-EMC	EMC-CON 3A1	\	\
Attenuator	\	10dB DC-6GHz	1650	May 24, 2022	May 23, 2023

RF Conducted Test					
Equipment	Manufacturer	Model#	Serial#	Last Cal.	Next Cal.
Power Metter	Keysight	E4419	\	May 24, 2022	May 23, 2023
Power Sensor (AV)	Keysight	E9300A	\	May 24, 2022	May 23, 2023
Signal Analyzer20kHz-26.5GHz	Keysight	N9020A	MY49100060	May 24, 2022	May 23, 2023
Spectrum Analyzer9kHz-40GHz	R&S	FSP40	\	May 24, 2022	May 23, 2023

Radiated Emissions Test (966 Chamber)					
Equipment	Manufacturer	Model#	Serial#	Last Cal.	Next Cal.
966 chamber	ChengYu	966 Room	966	Jun. 06. 2020	Jun. 05, 2023
Receiver	R&S	ESR3	102075	May 24, 2022	May 23, 2023
Receiver	R&S	ESRP	101154	May 24, 2022	May 23, 2023
Amplifier	SKET	LAPA_01G18 G-45dB	\	May 24, 2022	May 23, 2023
Amplifier	Schwarzbeck	BBV9744	9744-0037	May 24, 2022	May 23, 2023
TRILOG Broadband Antenna	Schwarzbeck	VULB9163	942	May 26, 2022	May 25, 2023
Horn Antenna	Schwarzbeck	BBHA9120D	1541	May 24, 2022	May 23, 2023
Horn Antenn(18GHz -40GHz)	Schwarzbeck	BBHA9170	00822	May 24, 2022	May 23, 2023
Amplifier(18G Hz-40GHz)	MITEQ	TTA1840-35- HG	2034381	May 24, 2022	May 23, 2023
Loop Antenna(9kHz -30MHz)	Schwarzbeck	FMZB1519B	00014	May 26, 2022	May 25, 2023
RF cables1(9kHz- 30MHz)	Huber+Suhnar	9kHz-30MHz	B1702988-000 8	May 26, 2022	May 25, 2023
RF cables2(30MH z-1GHz)	Huber+Suhnar	30MHz-1GHz	1486150	May 26, 2022	May 25, 2023
RF cables3(1GHz -40GHz)	Huber+Suhnar	1GHz-40GHz	1607106	May 24, 2022	May 23, 2023
Power Metter	Keysight	E4419	\	May 26, 2022	May 25, 2023
Power Sensor (AV)	Keysight	E9300A	\	May 26, 2022	May 25, 2023
Signal Analyzer20kH z-26.5GHz	Keysight	N9020A	MY49100060	May 26, 2022	May 25, 2023
Spectrum Analyzer9kHz- 40GHz	R&S	FSP40	\	May 26, 2022	May 25, 2023
Software	Frad	EZ-EMC	FA-03A2 RE	\	\

## 6. Conducted Emissions

### 6.1 Block Diagram Of Test Setup

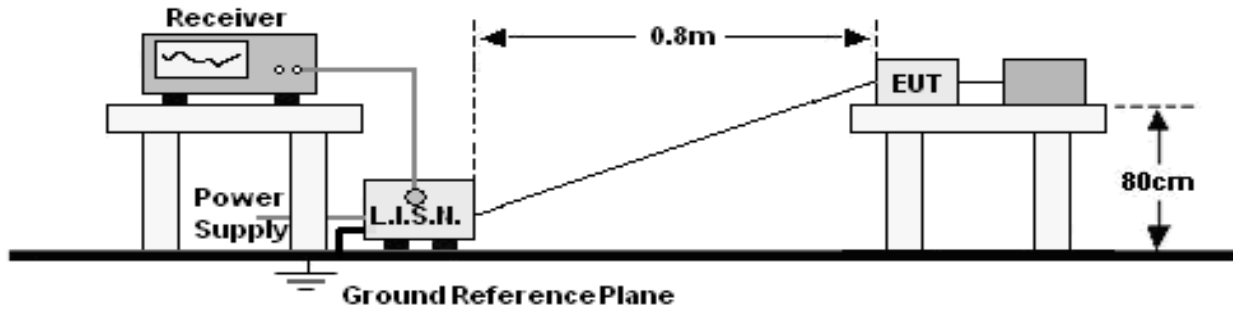

### 6.2 Limit

FREQUENCY (MHz)	Limit (dBuV)	
	Quas-peak	Average
0.15 -0.5	66 - 56 *	56 - 46 *
0.50 -5.0	56.00	46.00
5.0 -30.0	60.00	50.00

Notes:  
 1. \*Decreasing linearly with logarithm of frequency.  
 2. The lower limit shall apply at the transition frequencies.

### 6.3 Test Procedure

Receiver Parameters	Setting
Attenuation	10 dB
Start Frequency	0.15 MHz
Stop Frequency	30 MHz
IF Bandwidth	9 kHz

- The Product was placed on a nonconductive table 0.8 m above the horizontal ground reference plane, and 0.4 m from the vertical ground reference plane, and connected to the main through Line Impedance Stability Network (L.I.S.N).
- The RBW of the receiver was set at 9 kHz in 150 kHz ~ 30MHz with Peak and AVG detector in Max Hold mode. Run the receiver's pre-scan to record the maximum disturbance generated from Product in all power lines in the full band.
- For each frequency whose maximum record was higher or close to limit, measure its QP and AVG values and record.

### 6.4 EUT Operating Conditions

The EUT was configured for testing in a typical fashion (as a customer would normally use it). The EUT has been programmed to continuously transmit during test. This operating condition was tested and used to collect the included data.

We pretest AC 120V and AC 240V, the worst voltage was AC 120V and the data recording in the report.

### 6.5 Test Result

Temperature:	26 °C	Relative Humidity:	54%
Pressure:	101KPa	Phase :	L
Test Mode:	Mode 1	Test Voltage :	DC 5V from adapter

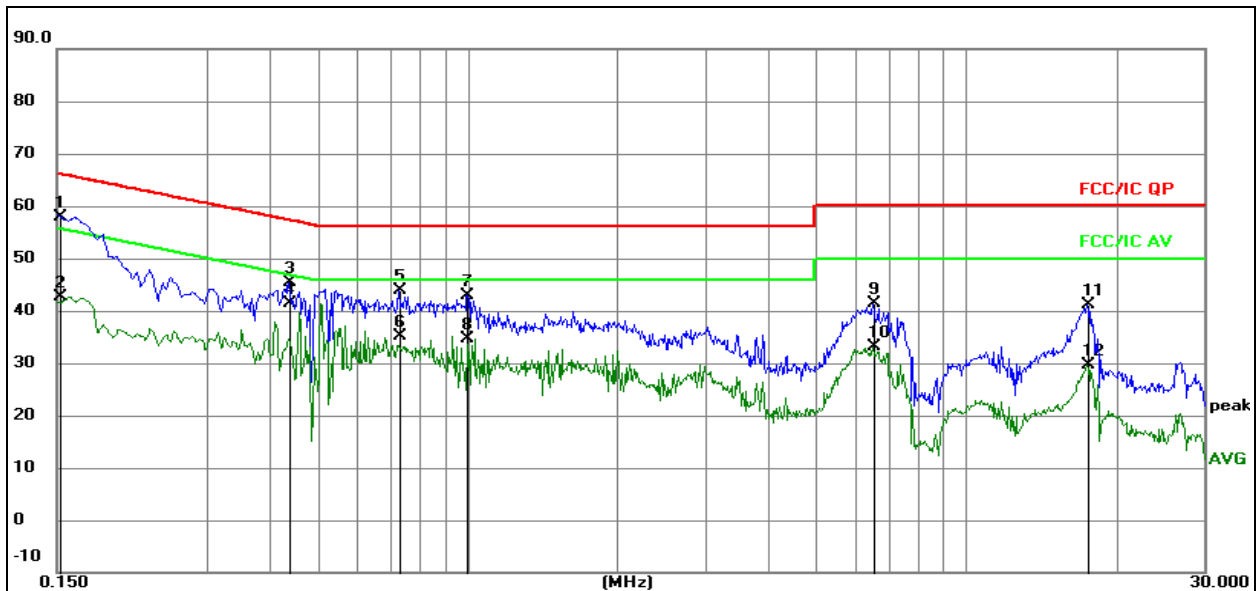

**Remark:**

1. All readings are Quasi-Peak and Average values.
2. Factor = Insertion Loss + Cable Loss.
3. Measurement=Reading Level+ Correct Factor
4. Over=Measurement-Limit

No. Mk.	Freq. MHz	Reading Level	Correct Factor dB	Measure- ment dBuV	Limit dBuV	Over dB	Detector
1	0.1524	38.29	19.68	57.97	65.87	-7.90	QP
2	0.1524	23.04	19.68	42.72	55.87	-13.15	AVG
3	0.4380	25.52	19.74	45.26	57.10	-11.84	QP
4 *	0.4380	21.57	19.74	41.31	47.10	-5.79	AVG
5	0.7304	24.10	19.74	43.84	56.00	-12.16	QP
6	0.7304	15.42	19.74	35.16	46.00	-10.84	AVG
7	0.9960	23.18	19.76	42.94	56.00	-13.06	QP
8	0.9960	14.90	19.76	34.66	46.00	-11.34	AVG
9	6.5130	21.13	20.17	41.30	60.00	-18.70	QP
10	6.5130	12.96	20.17	33.13	50.00	-16.87	AVG
11	17.5470	20.82	20.40	41.22	60.00	-18.78	QP
12	17.5470	9.26	20.40	29.66	50.00	-20.34	AVG

Temperature :	26 °C	Relative Humidity :	54%
Pressure :	101kPa	Phase :	Neutral
Test Voltage :	DC 5V from adapter	Test Mode :	Mode 2

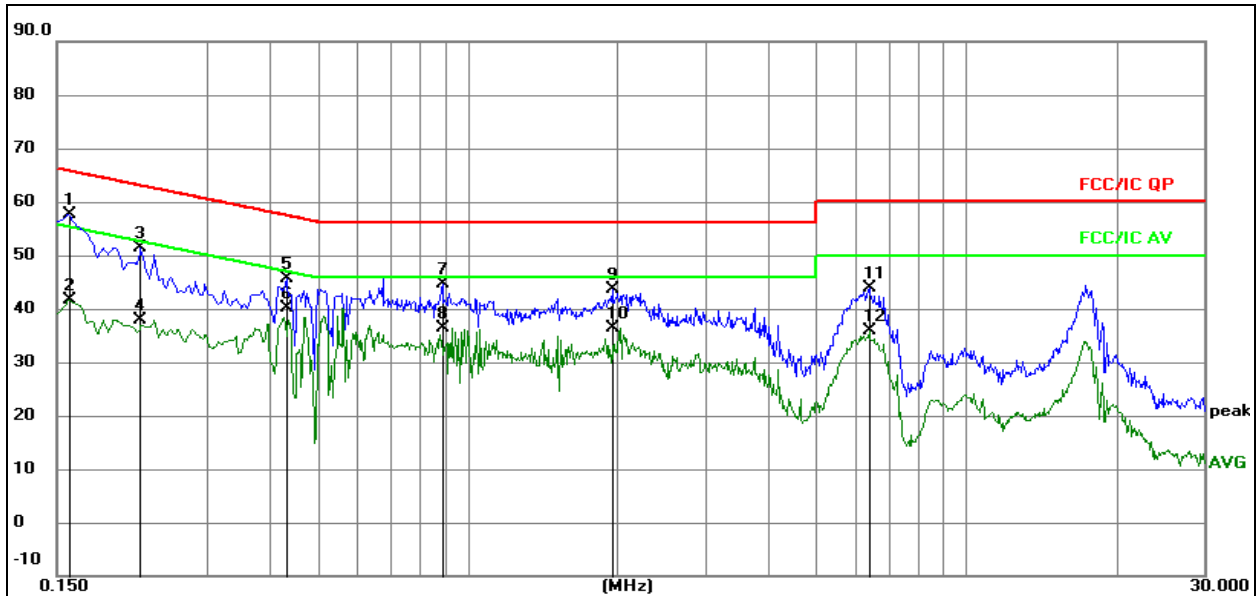
**Remark:**

1. All readings are Quasi-Peak and Average values.
2. Factor = Insertion Loss + Cable Loss.
3. Measurement=Reading Level+ Correct Factor
4. Over=Measurement-Limit

No.	Mk.	Freq. MHz	Reading Level	Correct Factor dB	Measure- ment dBuV	Limit dBuV	Over dB	Detector
1		0.1582	38.02	19.69	57.71	65.56	-7.85	QP
2		0.1582	21.90	19.69	41.59	55.56	-13.97	AVG
3		0.2208	31.55	19.79	51.34	62.79	-11.45	QP
4		0.2208	18.06	19.79	37.85	52.79	-14.94	AVG
5		0.4328	25.84	19.74	45.58	57.20	-11.62	QP
6	*	0.4328	20.51	19.74	40.25	47.20	-6.95	AVG
7		0.8897	24.92	19.75	44.67	56.00	-11.33	QP
8		0.8897	16.64	19.75	36.39	46.00	-9.61	AVG
9		1.9489	23.79	19.87	43.66	56.00	-12.34	QP
10		1.9489	16.52	19.87	36.39	46.00	-9.61	AVG
11		6.3859	23.71	20.16	43.87	60.00	-16.13	QP
12		6.3859	15.67	20.16	35.83	50.00	-14.17	AVG

## 7. Radiated Emissions

### 7.1 Block Diagram Of Test Setup

(A) Radiated Emission Test-Up Frequency Below 30MHz

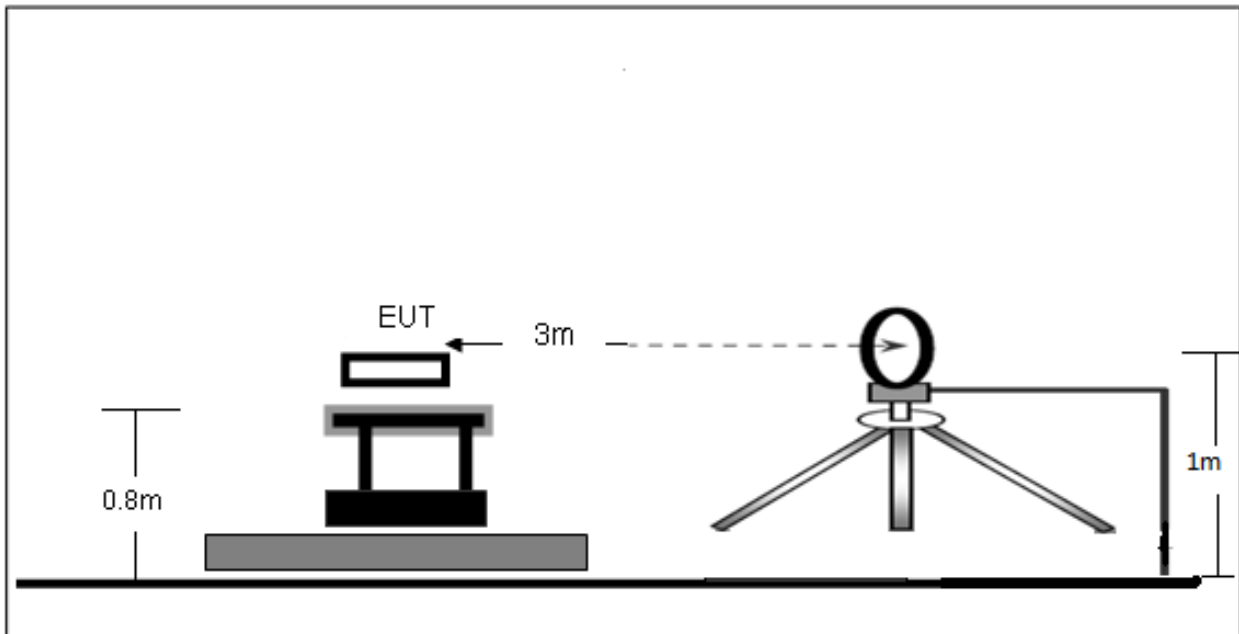

(B) Radiated Emission Test-Up Frequency 30MHz~1GHz

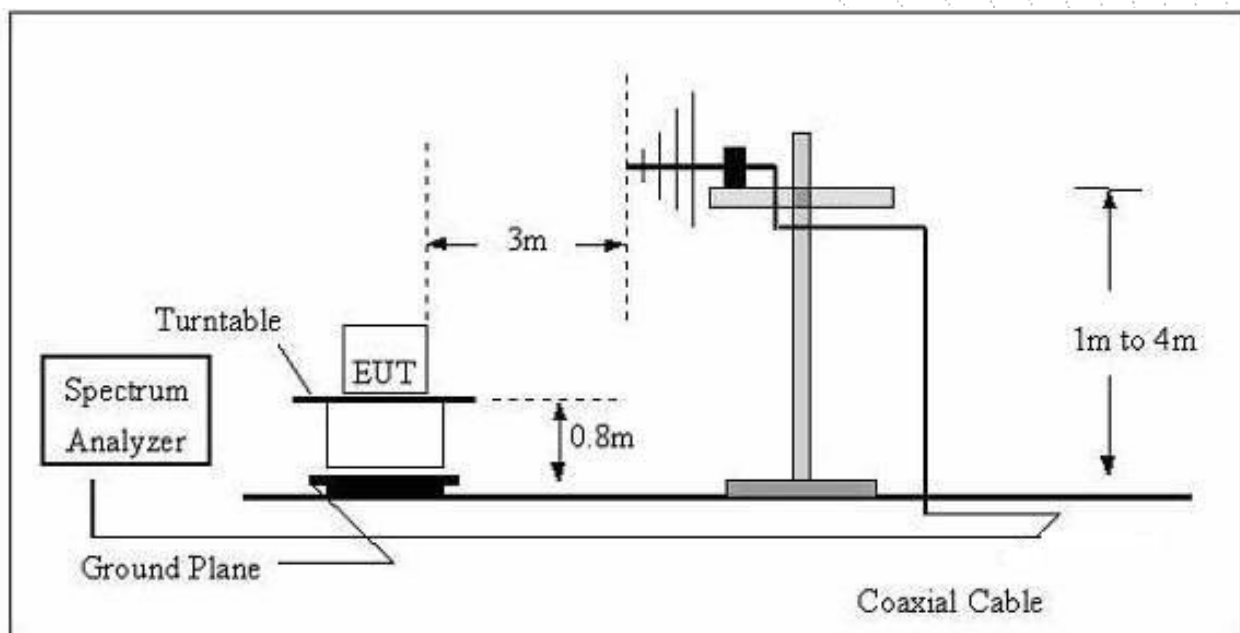



## (C) Radiated Emission Test-Up Frequency Above 1GHz

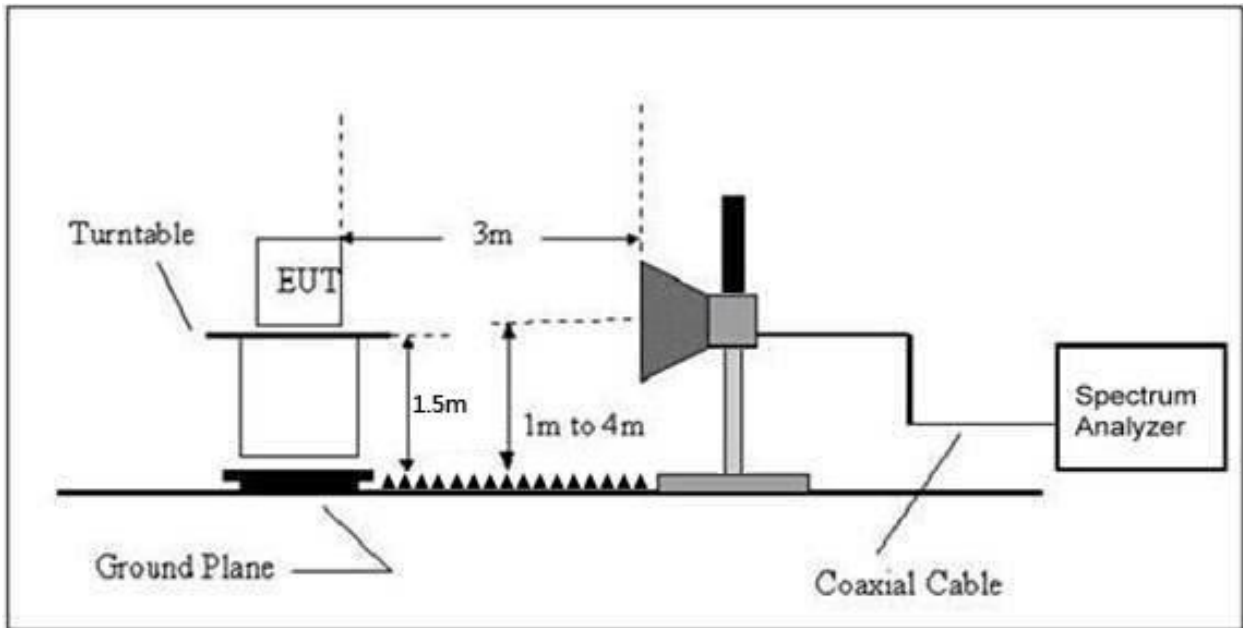

## 7.2 Limit

20dBc in any 100 kHz bandwidth outside the operating frequency band. In case the emission fall within the restricted band specified on 15.205(a), then the 15.209(a) limit in the table below has to be followed.

Frequency (MHz)	Field Strength uV/m	Distance (m)	Field Strength Limit at 3m Distance	
			uV/m	dBuV/m
0.009 ~ 0.490	$2400/F(\text{kHz})$	300	$10000 * 2400/F(\text{kHz})$	$20\log^{(2400/F(\text{kHz}))} + 80$
0.490 ~ 1.705	$24000/F(\text{kHz})$	30	$100 * 24000/F(\text{kHz})$	$20\log^{(24000/F(\text{kHz}))} + 40$
1.705 ~ 30	30	30	$100 * 30$	$20\log^{(30)} + 40$
30 ~ 88	100	3	100	$20\log^{(100)}$
88 ~ 216	150	3	150	$20\log^{(150)}$
216 ~ 960	200	3	200	$20\log^{(200)}$
Above 960	500	3	500	$20\log^{(500)}$

**LIMITS OF RADIATED EMISSION MEASUREMENT (Above 1000MHz)**

FREQUENCY (MHz)	Limit (dBuV/m) (at 3M)	
	PEAK	AVERAGE
Above 1000	74	54

**Notes:**

- (1)The limit for radiated test was performed according to FCC PART 15C.
- (2)The tighter limit applies at the band edges.
- (3) Emission level (dBuV/m)=20log Emission level (uV/m).

**7.3 Test Procedure**

The test site semi-anechoic chamber has met the requirement of NSA tolerance 4 dB according to the standards: ANSI C63.10-2013. The test distance is 3m. The setup is according to the requirements in Section 13.1.4.1 of ANSI C63.10-2013 and CAN/CSA-CEI/IEC CISPR 22.

This test is required for any spurious emission that falls in a Restricted Band, as defined in Section 15.205.

It must be performed with the highest gain of each type of antenna proposed for use with the EUT. Use the following spectrum analyzer settings:

Spectrum Parameter	Setting
Attenuation	Auto
Start Frequency	1000 MHz
Stop Frequency	10th carrier harmonic
RB / VB (emission in restricted band)	1 MHz / 1 MHz for Peak, 1 MHz / 10Hz for Average

Receiver Parameter	Setting
Attenuation	Auto
Start ~ Stop Frequency	9kHz~150kHz / RB 200Hz for QP
Start ~ Stop Frequency	150kHz~30MHz / RB 9kHz for QP
Start ~ Stop Frequency	30MHz~1000MHz / RB 120kHz for QP

- a. The measuring distance of at 3 m shall be used for measurements at frequency up to 1GHz. For frequencies above 1GHz, any suitable measuring distance may be used.
- b. The EUT was placed on the top of a rotating table 0.8 m for below 1GHz and 1.5m for above 1GHz the ground at a 3 meter. The table was rotated 360 degrees to determine the position of the highest radiation.
- c. The height of the equipment or of the substitution antenna shall be 0.8 m for below 1GHz and 1.5m for above 1GHz; the height of the test antenna shall vary between 1 m to 4 m. Both horizontal and vertical polarizations of the antenna are set to make the measurement.
- d. The initial step in collecting conducted emission data is a spectrum analyzer peak detector mode pre-scanning the measurement frequency range. Significant peaks are then marked and then Quasi Peak detector mode re-measured.
- e. If the Peak Mode measured value compliance with and lower than Quasi Peak Mode Limit, the EUT shall be deemed to meet QP Limits and then no additional QP Mode measurement performed.
- f. For the actual test configuration, please refer to the related Item –EUT Test Photos.

**Note:**

Both horizontal and vertical antenna polarities were tested and performed pretest to three orthogonal axis. The worst case emissions were reported

During the radiated emission test, the Spectrum Analyzer was set with the following configurations:

Frequency Band (MHz)	Function	Resolution bandwidth	Video Bandwidth
30 to 1000	QP	120 kHz	300 kHz
Above 1000	Peak	1 MHz	1 MHz
	Average	1 MHz	10 Hz

Note: for the frequency ranges below 30 MHz, a narrower RBW is used for these ranges but the measured value should add a RBW correction factor (RBWCF) where  $RBWCF [dB] = 10 \cdot \lg(100 [kHz]/\text{narrower RBW [kHz]})$ . , the narrower RBW is 1 kHz and RBWCF is 20 dB for the frequency 9 kHz to 150 kHz, and the narrower RBW is 10 kHz and RBWCF is 10 dB for the frequency 150 kHz to 30 MHz.

## 7.4 EUT Operating Conditions

The EUT was configured for testing in a typical fashion (as a customer would normally use it). The EUT has been programmed to continuously transmit during test. This operating condition was tested and used to collect the included data.

## 7.5 Test Result

Below 30MHz

Temperature:	26°C	Relative Humidity:	24%
Pressure:	101 kPa	Test Voltage :	DC 5V from adapter
Test Mode :	Mode 1	Polarization :	--

Freq. (MHz)	Reading (dBuV/m)	Limit (dBuV/m)	Margin (dB)	State P/F
--	--	--	--	PASS
--	--	--	--	PASS

**Note:**

The amplitude of spurious emissions which are attenuated by more than 20dB below the permissible value has no need to be reported.

Distance extrapolation factor =  $40 \log(\text{specific distance}/\text{test distance})(dB)$ ;

Limit line = specific limits(dBuv) + distance extrapolation factor.

Between 30MHz – 1GHz

Temperature:	26 °C	Relative Humidity:	54%
Pressure:	101KPa	Phase :	Horizontal
Test Mode:	Mode 1	Test Voltage :	DC 5V from adapter

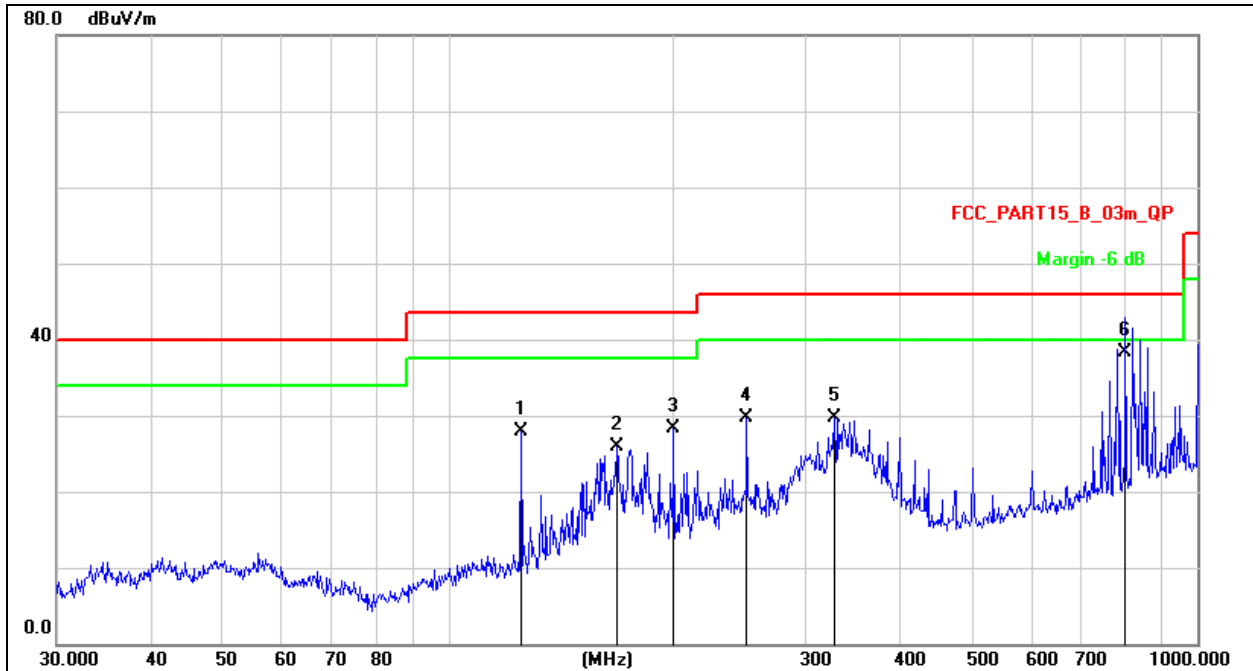

Remark:

1. Factor = Antenna Factor + Cable Loss – Pre-amplifier.
2. Measurement = Reading Level + Correct Factor
3. Over = Measurement - Limit

No.	Mk.	Freq.	Reading Level	Correct Factor	Measurement	Limit	Over	
		MHz	dBuV	dB	dBuV/m	dB/m	dB	Detector
1		125.0066	45.80	-17.89	27.91	43.50	-15.59	QP
2		167.8243	44.24	-18.36	25.88	43.50	-17.62	QP
3		199.9856	44.62	-16.30	28.32	43.50	-15.18	QP
4		250.3012	44.85	-15.14	29.71	46.00	-16.29	QP
5		327.8873	42.47	-12.84	29.63	46.00	-16.37	QP
6	*	799.9683	41.96	-3.64	38.32	46.00	-7.68	QP

Temperature:	26 °C	Relative Humidity:	54%
Pressure:	101KPa	Phase :	Vertical
Test Mode:	Mode 1	Test Voltage :	DC 5V from adapter

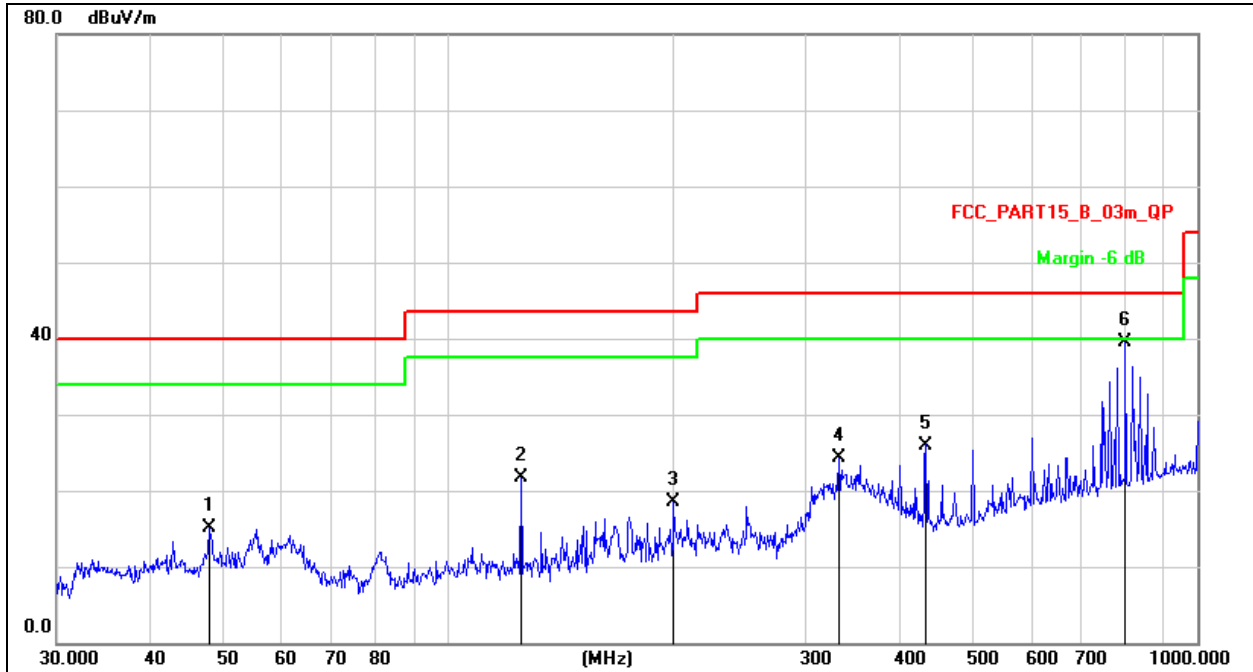

- Remark:
1. Factor = Antenna Factor + Cable Loss – Pre-amplifier.
  2. Measurement = Reading Level + Correct Factor
  3. Over = Measurement - Limit

No. Mk.	Freq. MHz	Reading Level dBuV	Correct Factor dB	Measure- ment dBuV/m	Limit dB/m	Over dB	Detector
1	47.9940	30.05	-14.96	15.09	40.00	-24.91	QP
2	125.0066	39.64	-17.89	21.75	43.50	-21.75	QP
3	199.9856	34.75	-16.30	18.45	43.50	-25.05	QP
4	332.5187	37.05	-12.71	24.34	46.00	-21.66	QP
5	434.0651	36.33	-10.33	26.00	46.00	-20.00	QP
6 *	801.7863	43.16	-3.60	39.56	46.00	-6.44	QP

Between 1GHz – 40GHz

Test Mode :	TX(5.1G) - 802.11a
-------------	--------------------

Polar	Frequency	Meter Reading	Cable loss	Antenna Factor	Preamp Factor	Emission Level	Limits	Margin	Detector Type
(H/V)	(MHz)	(dBuV)	(dB)	dB/m	(dB)	(dBuV/m)	(dBuV/m)	(dB)	
Low Channel (5180 MHz)-Above 1G									
V	4434.045	60.57	5.94	35.40	44.00	57.91	68.2	-10.29	PK
V	4434.045	43.74	5.94	35.40	44.00	41.08	54	-12.92	AV
V	10360.045	60.41	8.46	39.75	44.50	64.12	68.2	-4.08	PK
V	10360.045	43.07	8.46	39.75	44.50	46.78	54	-7.22	AV
V	15540.148	62.67	10.12	38.80	44.10	67.49	74	-6.51	PK
V	15540.148	43.28	10.12	38.80	42.70	49.50	54	-4.50	AV
H	4434.034	61.31	5.94	35.18	44.00	58.43	68.2	-9.77	PK
H	4434.034	43.86	5.94	35.18	44.00	40.98	54	-13.02	AV
H	10360.032	51.87	8.46	38.71	44.50	54.54	68.2	-13.66	PK
H	10360.032	44.69	8.46	38.71	44.50	47.36	54	-6.64	AV
H	15540.027	51.81	10.12	38.38	44.10	56.21	74	-17.79	PK
H	15540.027	44.59	10.12	38.38	44.10	48.99	54	-5.01	AV
middle Channel (5200 MHz)-Above 1G									
V	4592.190	60.84	6.48	36.35	44.05	59.62	74	-14.38	PK
V	4592.190	43.67	6.48	36.35	44.05	42.45	54	-11.55	AV
V	10400.131	60.67	8.47	37.88	44.51	62.51	68.2	-5.69	PK
V	10400.131	43.54	8.47	37.88	44.51	45.38	54	-8.62	AV
V	15600.156	64.84	10.12	38.80	44.10	69.66	74	-4.34	PK
V	15600.156	43.23	10.12	38.80	42.70	49.45	54	-4.55	AV
H	4592.193	62.47	6.48	36.37	44.05	61.27	74	-12.73	PK
H	4592.193	43.09	6.48	36.37	44.05	41.89	54	-12.11	AV
H	10400.196	53.51	8.47	38.64	44.50	56.12	68.2	-12.08	PK
H	10400.196	42.31	8.47	38.64	44.50	44.92	54	-9.08	AV
H	15600.104	53.44	10.12	38.38	44.10	57.84	74	-16.16	PK
H	15600.104	43.58	10.12	38.38	44.10	47.98	54	-6.02	AV
High Channel (5240 MHz)-Above 1G									
V	4739.141	61.86	7.10	37.24	43.50	62.70	74	-11.30	PK
V	4739.141	43.15	7.10	37.24	43.50	43.99	54	-10.01	AV
V	10480.082	62.83	8.46	37.68	44.50	64.47	68.2	-3.73	PK
V	10480.082	43.02	8.46	37.68	44.50	44.66	54	-9.34	AV
V	15720.130	62.29	10.12	38.80	44.10	67.11	74	-6.89	PK
V	15720.130	43.68	10.12	38.80	42.70	49.90	54	-4.10	AV
H	4739.006	61.06	7.10	37.24	43.50	61.90	74	-12.10	PK
H	4739.006	43.26	7.10	37.24	43.50	44.10	54	-9.90	AV
H	10480.032	52.01	8.46	38.57	44.50	54.54	68.2	-13.66	PK
H	10480.032	43.93	8.46	38.57	44.50	46.46	54	-7.54	AV
H	15720.135	54.49	10.12	38.38	44.10	58.89	74	-15.11	PK
H	15720.135	42.54	10.12	38.38	44.10	46.94	54	-7.06	AV

Note: PK value is lower than the Average value limit, So average didn't record.

The 26.5-40G amplitude of spurious emissions that are attenuated by more than 20dB below the permissible value has no need to be reported.

Emission level (dBuV/m) = 20 log Emission level (uV/m).

Corrected Reading: Antenna Factor + Cable Loss + Read Level - Preamp Factor = Level.

Test Mode :	TX(5.1G) - 802.11n-HT20
-------------	-------------------------

Polar	Frequency	Meter Reading	Cable loss	Antenna Factor	Preamp Factor	Emission Level	Limits	Margin	Detector Type
(H/V)	(MHz)	(dBuV)	(dB)	dB/m	(dB)	(dBuV/m)	(dBuV/m)	(dB)	
Low Channel (5180 MHz)-Above 1G									
V	4434.066	60.76	5.94	35.40	44.00	58.10	68.2	-10.10	PK
V	4434.066	43.40	5.94	35.40	44.00	40.74	54	-13.26	AV
V	10360.089	63.00	8.46	39.75	44.50	66.71	68.2	-1.49	PK
V	10360.089	43.79	8.46	39.75	44.50	47.50	54	-6.50	AV
V	15540.184	60.28	10.12	38.80	44.10	65.10	74	-8.90	PK
V	15540.184	43.46	10.12	38.80	42.70	49.68	54	-4.32	AV
H	4434.181	63.48	5.94	35.18	44.00	60.60	68.2	-7.60	PK
H	4434.181	43.08	5.94	35.18	44.00	40.20	54	-13.80	AV
H	10360.017	50.48	8.46	38.71	44.50	53.15	68.2	-15.05	PK
H	10360.017	42.14	8.46	38.71	44.50	44.81	54	-9.19	AV
H	15540.146	51.46	10.12	38.38	44.10	55.86	74	-18.14	PK
H	15540.146	44.09	10.12	38.38	44.10	48.49	54	-5.51	AV
middle Channel (5200 MHz)-Above 1G									
V	4592.074	63.84	6.48	36.35	44.05	62.62	74	-11.38	PK
V	4592.074	43.73	6.48	36.35	44.05	42.51	54	-11.49	AV
V	10400.089	63.36	8.47	37.88	44.51	65.20	68.2	-3.00	PK
V	10400.089	43.95	8.47	37.88	44.51	45.79	54	-8.21	AV
V	15600.005	64.60	10.12	38.80	44.10	69.42	74	-4.58	PK
V	15600.005	43.03	10.12	38.80	42.70	49.25	54	-4.75	AV
H	4592.060	62.27	6.48	36.37	44.05	61.07	74	-12.93	PK
H	4592.060	43.92	6.48	36.37	44.05	42.72	54	-11.28	AV
H	10400.017	52.68	8.47	38.64	44.50	55.29	68.2	-12.91	PK
H	10400.017	40.53	8.47	38.64	44.50	43.14	54	-10.86	AV
H	15600.191	51.77	10.12	38.38	44.10	56.17	74	-17.83	PK
H	15600.191	41.95	10.12	38.38	44.10	46.35	54	-7.65	AV
High Channel (5240 MHz)-Above 1G									
V	4739.075	62.17	7.10	37.24	43.50	63.01	74	-10.99	PK
V	4739.075	43.46	7.10	37.24	43.50	44.30	54	-9.70	AV
V	10480.075	64.33	8.46	37.68	44.50	65.97	68.2	-2.23	PK
V	10480.075	43.22	8.46	37.68	44.50	44.86	54	-9.14	AV
V	15720.077	64.91	10.12	38.80	44.10	69.73	74	-4.27	PK
V	15720.077	43.69	10.12	38.80	42.70	49.91	54	-4.09	AV
H	4739.134	62.66	7.10	37.24	43.50	63.50	74	-10.50	PK
H	4739.134	43.22	7.10	37.24	43.50	44.06	54	-9.94	AV
H	10480.132	52.04	8.46	38.57	44.50	54.57	68.2	-13.63	PK
H	10480.132	41.37	8.46	38.57	44.50	43.90	54	-10.10	AV
H	15720.101	51.07	10.12	38.38	44.10	55.47	74	-18.53	PK
H	15720.101	44.84	10.12	38.38	44.10	49.24	54	-4.76	AV

Note: PK value is lower than the Average value limit, So average didn't record.

The 26.5-40G amplitude of spurious emissions that are attenuated by more than 20dB below the permissible value has no need to be reported.

Emission level (dBuV/m) = 20 log Emission level (uV/m).

Corrected Reading: Antenna Factor + Cable Loss + Read Level - Preamp Factor = Level.

Test Mode :	TX(5.1G) - 802.11n-HT40
-------------	-------------------------

Polar	Frequency	Meter Reading	Cable loss	Antenna Factor	Preamp Factor	Emission Level	Limits	Margin	Detector Type
(H/V)	(MHz)	(dBuV)	(dB)	dB/m	(dB)	(dBuV/m)	(dBuV/m)	(dB)	
Low Channel (5190 MHz)-Above 1G									
V	4434.169	62.30	5.94	35.40	44.00	59.64	68.2	-8.56	PK
V	4434.169	43.77	5.94	35.40	44.00	41.11	54	-12.89	AV
V	10380.043	60.83	8.46	39.75	44.50	64.54	68.2	-3.66	PK
V	10380.043	43.28	8.46	39.75	44.50	46.99	54	-7.01	AV
V	15570.180	60.46	10.12	38.80	44.10	65.28	74	-8.72	PK
V	15570.180	43.46	10.12	38.80	42.70	49.68	54	-4.32	AV
H	4434.044	62.88	5.94	35.18	44.00	60.00	74	-14.00	PK
H	4434.044	43.83	5.94	35.18	44.00	40.95	54	-13.05	AV
H	10380.045	51.96	8.46	38.71	44.50	54.63	68.2	-13.57	PK
H	10380.045	43.37	8.46	38.71	44.50	46.04	54	-7.96	AV
H	15570.045	51.22	10.12	38.38	44.10	55.62	74	-18.38	PK
H	15570.045	40.77	10.12	38.38	44.10	45.17	54	-8.83	AV
middle Channel (5230 MHz)-Above 1G									
V	4739.011	61.17	6.48	36.35	44.05	59.95	68.2	-8.25	PK
V	4739.011	43.24	6.48	36.35	44.05	42.02	54	-11.98	AV
V	10460.117	60.69	8.47	37.88	44.51	62.53	68.2	-5.67	PK
V	10460.117	43.09	8.47	37.88	44.51	44.93	54	-9.07	AV
V	15690.090	64.07	10.12	38.80	44.10	68.89	74	-5.11	PK
V	15690.090	43.37	10.12	38.80	42.70	49.59	54	-4.41	AV
H	4739.071	63.80	6.48	36.37	44.05	62.60	68.2	-5.60	PK
H	4739.071	43.38	6.48	36.37	44.05	42.18	54	-11.82	AV
H	10460.166	52.22	8.47	38.64	44.50	54.83	68.2	-13.37	PK
H	10460.166	42.10	8.47	38.64	44.50	44.71	54	-9.29	AV
H	15690.055	52.15	10.12	38.38	44.10	56.55	74	-17.45	PK
H	15690.055	43.66	10.12	38.38	44.10	48.06	54	-5.94	AV

Note: PK value is lower than the Average value limit, So average didn't record.

The 26.5-40G amplitude of spurious emissions that are attenuated by more than 20dB below the permissible value has no need to be reported.

Emission level (dBuV/m) = 20 log Emission level (uV/m).

Corrected Reading: Antenna Factor + Cable Loss + Read Level - Preamp Factor = Level.



Test Mode :	TX(5.1G) - 802.11 AC20
-------------	------------------------

Polar	Frequency	Meter Reading	Cable loss	Antenna Factor	Preamp Factor	Emission Level	Limits	Margin	Detector Type
(H/V)	(MHz)	(dBuV)	(dB)	dB/m	(dB)	(dBuV/m)	(dBuV/m)	(dB)	
Low Channel (5180 MHz)-Above 1G									
V	4434.050	62.43	5.94	35.40	44.00	59.77	68.2	-8.43	PK
V	4434.050	43.45	5.94	35.40	44.00	40.79	54	-13.21	AV
V	10360.130	60.38	8.46	39.75	44.50	64.09	68.2	-4.11	PK
V	10360.130	43.18	8.46	39.75	44.50	46.89	54	-7.11	AV
V	15540.119	61.37	10.12	38.80	44.10	66.19	74	-7.81	PK
V	15540.119	43.88	10.12	38.80	42.70	50.10	54	-3.90	AV
H	4434.123	62.89	5.94	35.18	44.00	60.01	68.2	-8.19	PK
H	4434.123	43.60	5.94	35.18	44.00	40.72	54	-13.28	AV
H	10360.067	51.58	8.46	38.71	44.50	54.25	68.2	-13.95	PK
H	10360.067	42.36	8.46	38.71	44.50	45.03	54	-8.97	AV
H	15540.082	54.37	10.12	38.38	44.10	58.77	74	-15.23	PK
H	15540.082	41.79	10.12	38.38	44.10	46.19	54	-7.81	AV
middle Channel (5200 MHz)-Above 1G									
V	4592.091	63.59	6.48	36.35	44.05	62.37	74	-11.63	PK
V	4592.091	43.89	6.48	36.35	44.05	42.67	54	-11.33	AV
V	10400.125	60.96	8.47	37.88	44.51	62.80	68.2	-5.40	PK
V	10400.125	43.02	8.47	37.88	44.51	44.86	54	-9.14	AV
V	15600.050	64.56	10.12	38.80	44.10	69.38	74	-4.62	PK
V	15600.050	43.96	10.12	38.80	42.70	50.18	54	-3.82	AV
H	4592.007	62.34	6.48	36.37	44.05	61.14	74	-12.86	PK
H	4592.007	43.65	6.48	36.37	44.05	42.45	54	-11.55	AV
H	10400.073	53.04	8.47	38.64	44.50	55.65	68.2	-12.55	PK
H	10400.073	44.21	8.47	38.64	44.50	46.82	54	-7.18	AV
H	15600.151	52.59	10.12	38.38	44.10	56.99	74	-17.01	PK
H	15600.151	40.90	10.12	38.38	44.10	45.30	54	-8.70	AV
High Channel (5240 MHz)-Above 1G									
V	4739.108	62.16	7.10	37.24	43.50	63.00	74	-11.00	PK
V	4739.108	43.15	7.10	37.24	43.50	43.99	54	-10.01	AV
V	10480.152	64.15	8.46	37.68	44.50	65.79	68.2	-2.41	PK
V	10480.152	43.50	8.46	37.68	44.50	45.14	54	-8.86	AV
V	15720.101	63.66	10.12	38.80	44.10	68.48	74	-5.52	PK
V	15720.101	43.22	10.12	38.80	42.70	49.44	54	-4.56	AV
H	4739.002	61.38	7.10	37.24	43.50	62.22	74	-11.78	PK
H	4739.002	43.82	7.10	37.24	43.50	44.66	54	-9.34	AV
H	10480.148	53.78	8.46	38.57	44.50	56.31	68.2	-11.89	PK
H	10480.148	44.52	8.46	38.57	44.50	47.05	54	-6.95	AV
H	15720.009	50.71	10.12	38.38	44.10	55.11	74	-18.89	PK
H	15720.009	44.12	10.12	38.38	44.10	48.52	54	-5.48	AV

Note: PK value is lower than the Average value limit, So average didn't record.

The 26.5-40G amplitude of spurious emissions that are attenuated by more than 20dB below the permissible value has no need to be reported.

Emission level (dBuV/m) = 20 log Emission level (uV/m).

Corrected Reading: Antenna Factor + Cable Loss + Read Level - Preamp Factor = Level.

Test Mode :	TX(5.1G) - 802.11 AC40
-------------	------------------------

Polar	Frequency	Meter Reading	Cable loss	Antenna Factor	Preamp Factor	Emission Level	Limits	Margin	Detector Type
(H/V)	(MHz)	(dBuV)	(dB)	dB/m	(dB)	(dBuV/m)	(dBuV/m)	(dB)	
Low Channel (5190 MHz)-Above 1G									
V	4434.015	63.45	5.94	35.40	44.00	60.79	68.2	-7.41	PK
V	4434.015	43.27	5.94	35.40	44.00	40.61	54	-13.39	AV
V	10380.055	62.20	8.46	39.75	44.50	65.91	68.2	-2.29	PK
V	10380.055	43.51	8.46	39.75	44.50	47.22	54	-6.78	AV
V	15570.057	62.34	10.12	38.80	44.10	67.16	74	-6.84	PK
V	15570.057	43.81	10.12	38.80	42.70	50.03	54	-3.97	AV
H	4434.157	62.64	5.94	35.18	44.00	59.76	74	-14.24	PK
H	4434.157	43.34	5.94	35.18	44.00	40.46	54	-13.54	AV
H	10380.097	50.64	8.46	38.71	44.50	53.31	68.2	-14.89	PK
H	10380.097	41.84	8.46	38.71	44.50	44.51	54	-9.49	AV
H	15570.068	50.43	10.12	38.38	44.10	54.83	74	-19.17	PK
H	15570.068	41.65	10.12	38.38	44.10	46.05	54	-7.95	AV
middle Channel (5230 MHz)-Above 1G									
V	4739.009	61.67	6.48	36.35	44.05	60.45	68.2	-7.75	PK
V	4739.009	43.25	6.48	36.35	44.05	42.03	54	-11.97	AV
V	10460.159	62.44	8.47	37.88	44.51	64.28	68.2	-3.92	PK
V	10460.159	43.95	8.47	37.88	44.51	45.79	54	-8.21	AV
V	15690.098	64.03	10.12	38.80	44.10	68.85	74	-5.15	PK
V	15690.098	43.91	10.12	38.80	42.70	50.13	54	-3.87	AV
H	4739.178	63.11	6.48	36.37	44.05	61.91	68.2	-6.29	PK
H	4739.178	43.56	6.48	36.37	44.05	42.36	54	-11.64	AV
H	10460.195	51.45	8.47	38.64	44.50	54.06	68.2	-14.14	PK
H	10460.195	42.94	8.47	38.64	44.50	45.55	54	-8.45	AV
H	15690.143	54.84	10.12	38.38	44.10	59.24	74	-14.76	PK
H	15690.143	43.96	10.12	38.38	44.10	48.36	54	-5.64	AV

Note: PK value is lower than the Average value limit, So average didn't record.

The 26.5-40G amplitude of spurious emissions that are attenuated by more than 20dB below the permissible value has no need to be reported.

Emission level (dBuV/m) = 20 log Emission level (uV/m).

Corrected Reading: Antenna Factor + Cable Loss + Read Level - Preamp Factor = Level.

Test Mode :	TX(5.1G) - 802.11 AC80
-------------	------------------------

Polar	Frequency	Meter Reading	Cable loss	Antenna Factor	Preamp Factor	Emission Level	Limits	Margin	Detector Type
(H/V)	(MHz)	(dBuV)	(dB)	dB/m	(dB)	(dBuV/m)	(dBuV/m)	(dB)	
(5210 MHz)-Above 1G									
V	4434.147	60.17	5.94	35.40	44.00	57.51	68.2	-10.69	PK
V	4434.147	43.36	5.94	35.40	44.00	40.70	54	-13.30	AV
V	10420.072	61.15	8.46	39.75	44.50	64.86	68.2	-3.34	PK
V	10420.072	43.42	8.46	39.75	44.50	47.13	54	-6.87	AV
V	15630.164	63.43	10.12	38.80	44.10	68.25	74	-5.75	PK
V	15630.164	43.99	10.12	38.80	42.70	50.21	54	-3.79	AV
H	4434.039	64.90	5.94	35.18	44.00	62.02	68.2	-6.18	PK
H	4434.039	43.48	5.94	35.18	44.00	40.60	54	-13.40	AV
H	10420.041	50.85	8.46	38.71	44.50	53.52	68.2	-14.68	PK
H	10420.041	40.52	8.46	38.71	44.50	43.19	54	-10.81	AV
H	15630.080	50.97	10.12	38.38	44.10	55.37	74	-18.63	PK
H	15630.080	43.85	10.12	38.38	44.10	48.25	54	-5.75	AV

Note: PK value is lower than the Average value limit, So average didn't record.

The 26.5-40G amplitude of spurious emissions that are attenuated by more than 20dB below the permissible value has no need to be reported.

Emission level (dBuV/m) = 20 log Emission level (uV/m).

Corrected Reading: Antenna Factor + Cable Loss + Read Level - Preamp Factor = Level.

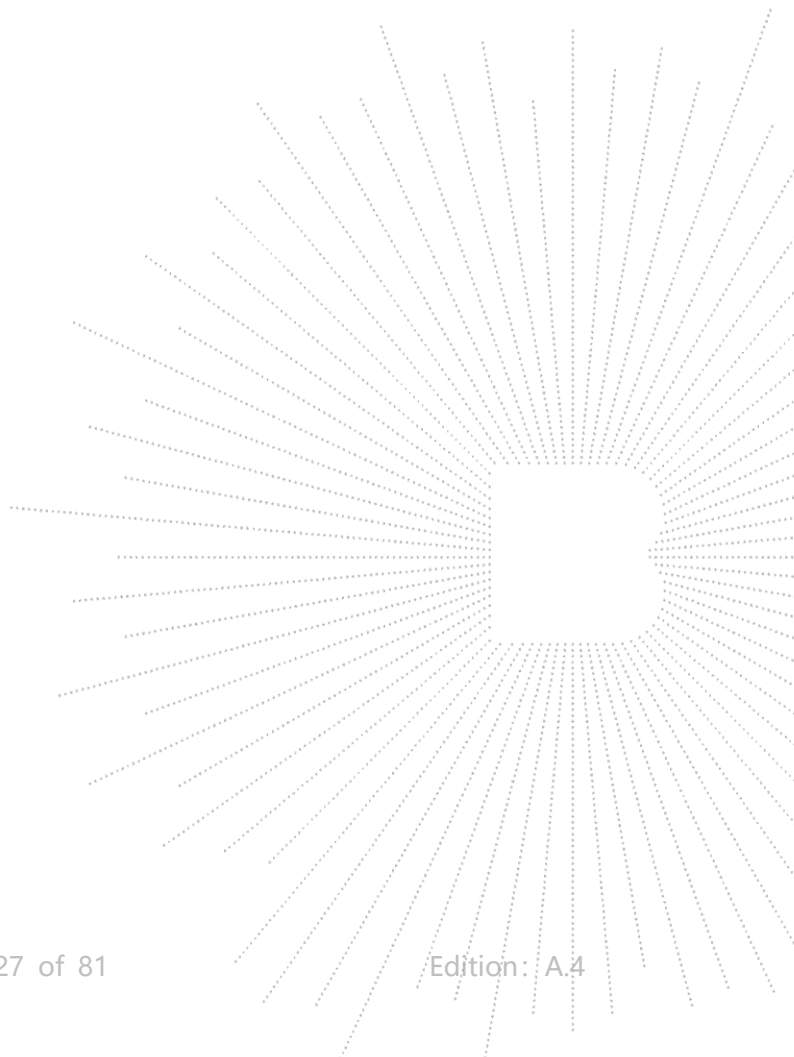

## 8. Power Spectral Density Test

### 8.1 Block Diagram Of Test Setup

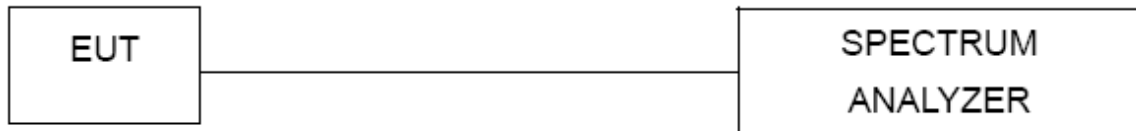

### 8.2 Limit

For the band 5.15-5.25 GHz,

(i) For an outdoor access point operating in the band 5.15-5.25 GHz, the maximum power spectral density shall not exceed 17 dBm in any 1 megahertz band. If transmitting antennas of directional gain greater than 6 dBi are used, both the maximum conducted output power and the maximum power spectral density shall be reduced by the amount in dB that the directional gain of the antenna exceeds 6 dBi. The maximum e.i.r.p. at any elevation angle above 30 degrees as measured from the horizon must not exceed 125 mW (21 dBm).

(ii) For an indoor access point operating in the band 5.15-5.25 GHz, the maximum power spectral density shall not exceed 17 dBm in any 1 megahertz band. If transmitting antennas of directional gain greater than 6 dBi are used, both the maximum conducted output power and the maximum power spectral density shall be reduced by the amount in dB that the directional gain of the antenna exceeds 6 dBi.

(iii) For fixed point-to-point access points operating in the band 5.15-5.25 GHz, the maximum power spectral density shall not exceed 17 dBm in any 1 megahertz band. Fixed point-to-point U-NII devices may employ antennas with directional gain up to 23 dBi without any corresponding reduction in the maximum conducted output power or maximum power spectral density. For fixed point-to-point transmitters that employ a directional antenna gain greater than 23 dBi, a 1 dB reduction in maximum conducted output power and maximum power spectral density is required for each 1 dB of antenna gain in excess of 23 dBi. Fixed, point-to-point operations exclude the use of point-to-multipoint systems, omnidirectional applications, and multiple collocated transmitters transmitting the same information. The operator of the U-NII device, or if the equipment is professionally installed, the installer, is responsible for ensuring that systems employing high gain directional antennas are used exclusively for fixed, point-to-point operations.

(iv) For client devices in the 5.15-5.25 GHz band, the maximum power spectral density shall not exceed 11 dBm in any 1 megahertz band. If transmitting antennas of directional gain greater than 6 dBi are used, both the maximum conducted output power and the maximum power spectral density shall be reduced by the amount in dB that the directional gain of the antenna exceeds 6 dBi.

For the band 5.725-5.85 GHz

(3) For the band 5.725-5.85 GHz, the maximum power spectral density shall not exceed 30 dBm in any 500-kHz band. If transmitting antennas of directional gain greater than 6 dBi are used, both the maximum conducted output power and the maximum power spectral density shall be reduced by the amount in dB that the directional gain of the antenna exceeds 6 dBi.

### 8.3 Test Procedure

For devices operating in the bands 5.15-5.25 GHz, 5.25-5.35 GHz, and 5.47-5.725 GHz, the above procedures make use of 1 MHz RBW to satisfy directly the 1 MHz reference bandwidth specified in § 15.407(a)(5). For devices operating in the band 5.725-5.85 GHz, the rules specify a measurement bandwidth of 500 kHz. Many spectrum analyzers do not have 500 kHz RBW, thus a narrower RBW may need to be used. The rules permit the use of a RBWs less than 1 MHz, or 500 kHz, “provided that the measured power is integrated over the full reference bandwidth” to show the total power over the specified measurement bandwidth (i.e., 1 MHz, or 500 kHz). If measurements are performed using a reduced resolution bandwidth (< 1 MHz, or < 500 kHz) and integrated over 1 MHz, or 500 KHz bandwidth, the following adjustments to the procedures apply:

- a) Set  $RBW \geq 1/T$ , where T is defined in section II.B.I.a).
- b) Set  $VBW \geq 3 RBW$ .
- c) If measurement bandwidth of Maximum PSD is specified in 500 kHz, add  $10\log(500\text{kHz}/RBW)$  to the measured result, whereas RBW (< 500 KHz) is the reduced resolution bandwidth of the spectrum analyzer set during measurement.
- d) If measurement bandwidth of Maximum PSD is specified in 1 MHz, add  $10\log(1\text{MHz}/RBW)$  to the measured result, whereas RBW (< 1 MHz) is the reduced resolution bandwidth of spectrum analyzer set during measurement.
- e) Care must be taken to ensure that the measurements are performed during a period of continuous transmission or are corrected upward for duty cycle.

Note: As a practical matter, it is recommended to use reduced RBW of 100 KHz for the sections 5.c) and 5.d) above, since RBW=100 KHZ is available on nearly all spectrum analyzers.

### 8.4 EUT Operating Conditions

The EUT was configured for testing in a typical fashion (as a customer would normally use it). The EUT has been programmed to continuously transmit during test. This operating condition was tested and used to collect the included data.

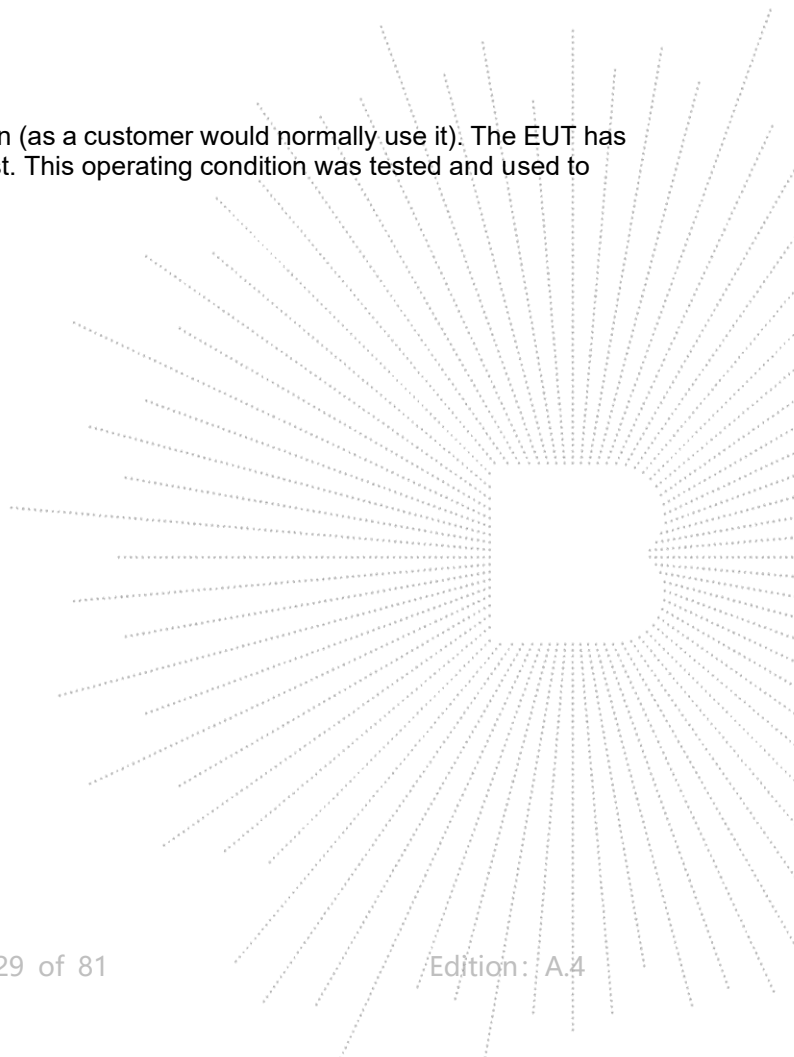

## 8.5 Test Result

Temperature :	26 °C	Relative Humidity :	54%
Pressure :	101kPa	Test Voltage :	DC 5V from adapter
Test Mode :	TX Frequency U-NII-1 (5180-5240MHz)		

Test Mode	Frequency	Measured Power Density (dBm/MHz)	Limit (dBm/MHz)	Result
802.11 a	5180 MHz	-1.58	11	PASS
	5200 MHz	0.83	11	PASS
	5240 MHz	-2.23	11	PASS
802.11 n20	5180 MHz	-3.4	11	PASS
	5200 MHz	-4.34	11	PASS
	5240 MHz	-3.35	11	PASS
802.11 n40	5190 MHz	-7.94	11	PASS
	5230 MHz	-9.82	11	PASS
802.11 AC20	5180 MHz	-3.06	11	PASS
	5200 MHz	-2.72	11	PASS
	5240 MHz	-2.78	11	PASS
802.11 AC40	5190 MHz	-8.54	11	PASS
	5230 MHz	-7.71	11	PASS
802.11 AC80	5210 MHz	-13.82	11	PASS

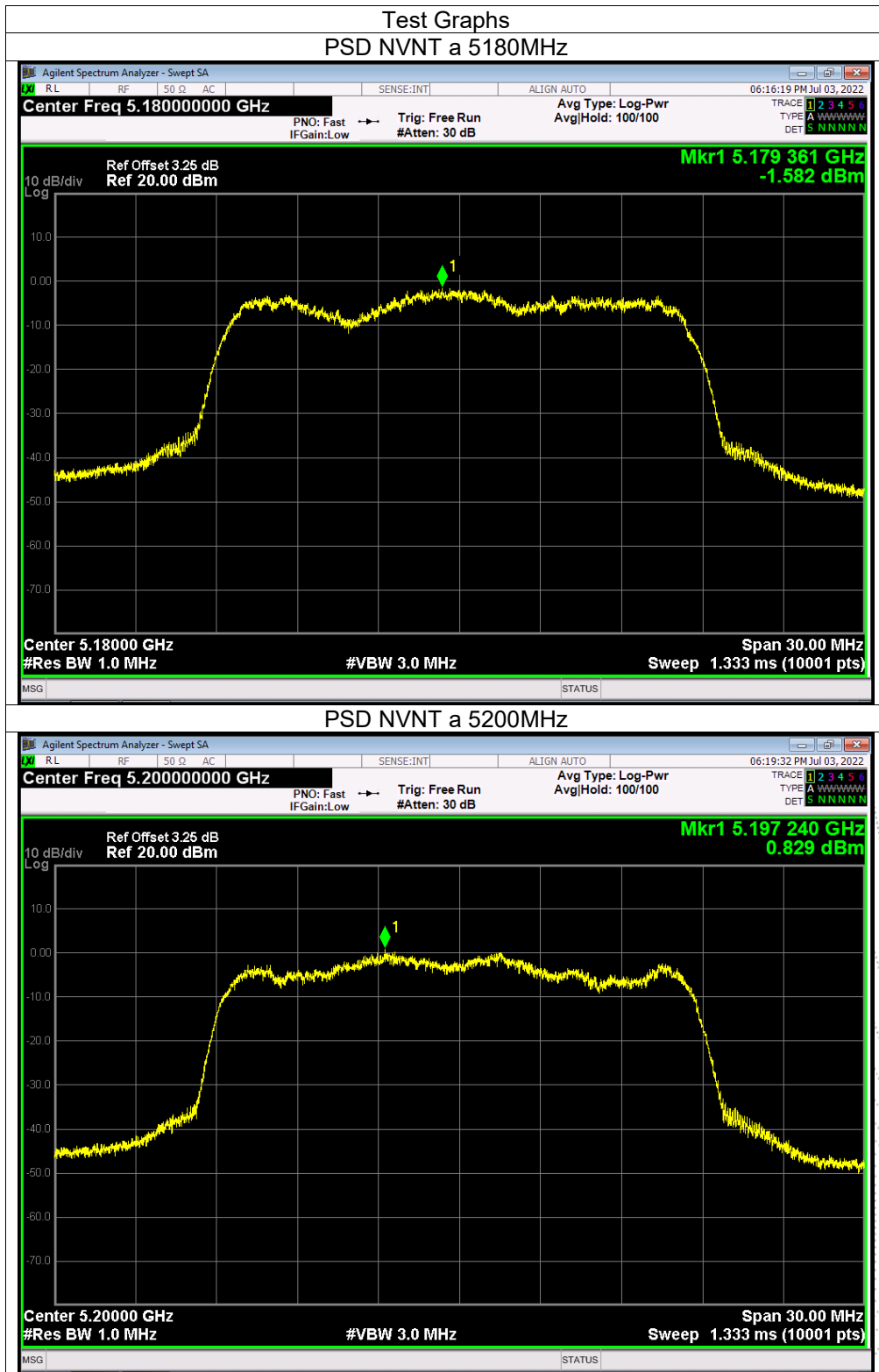

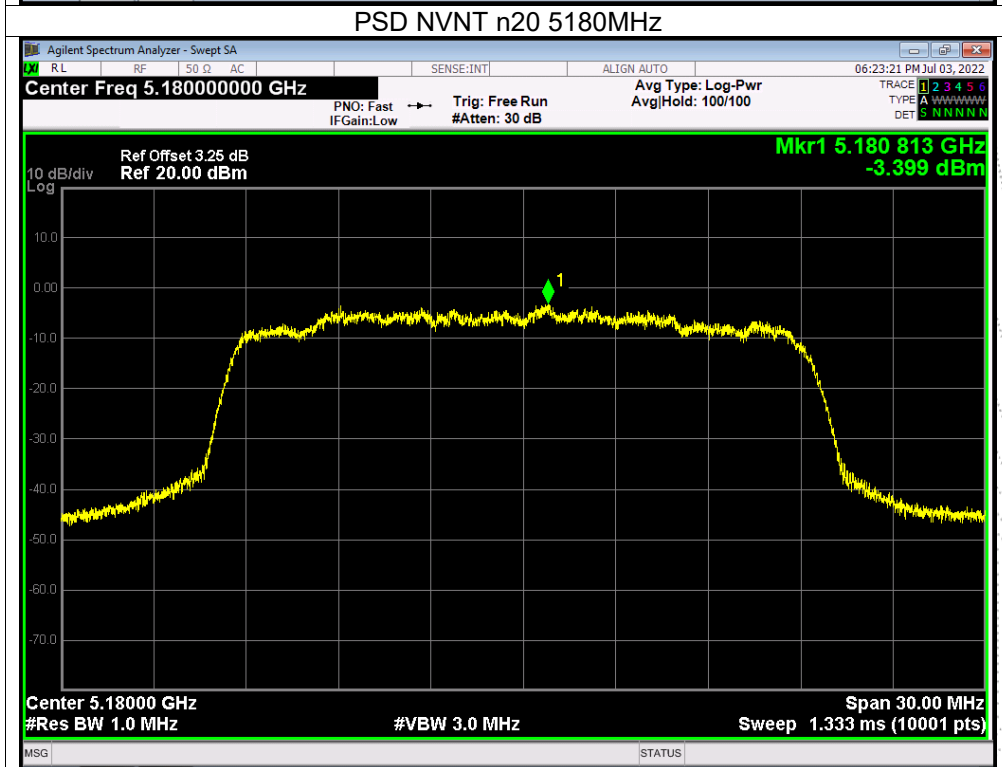
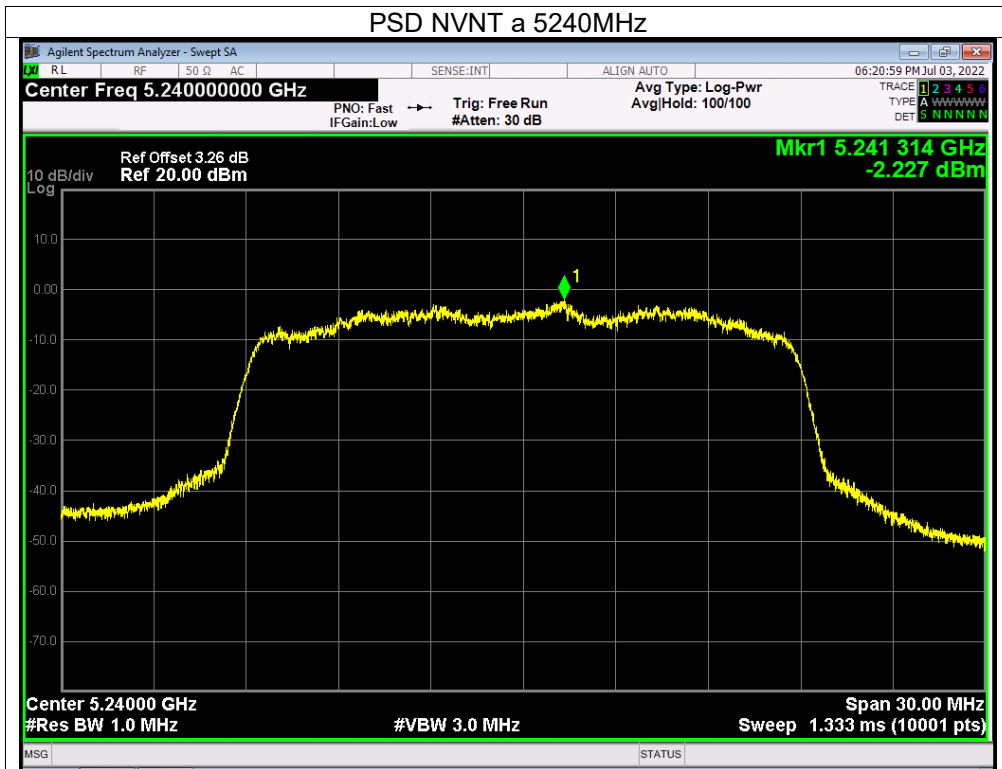



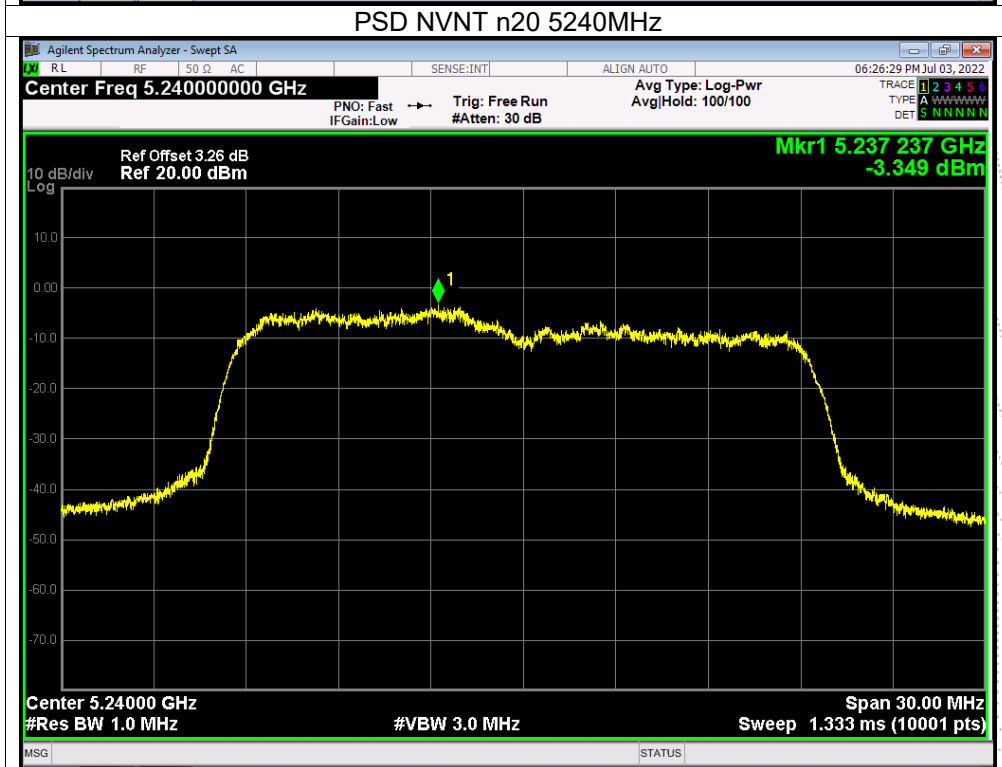
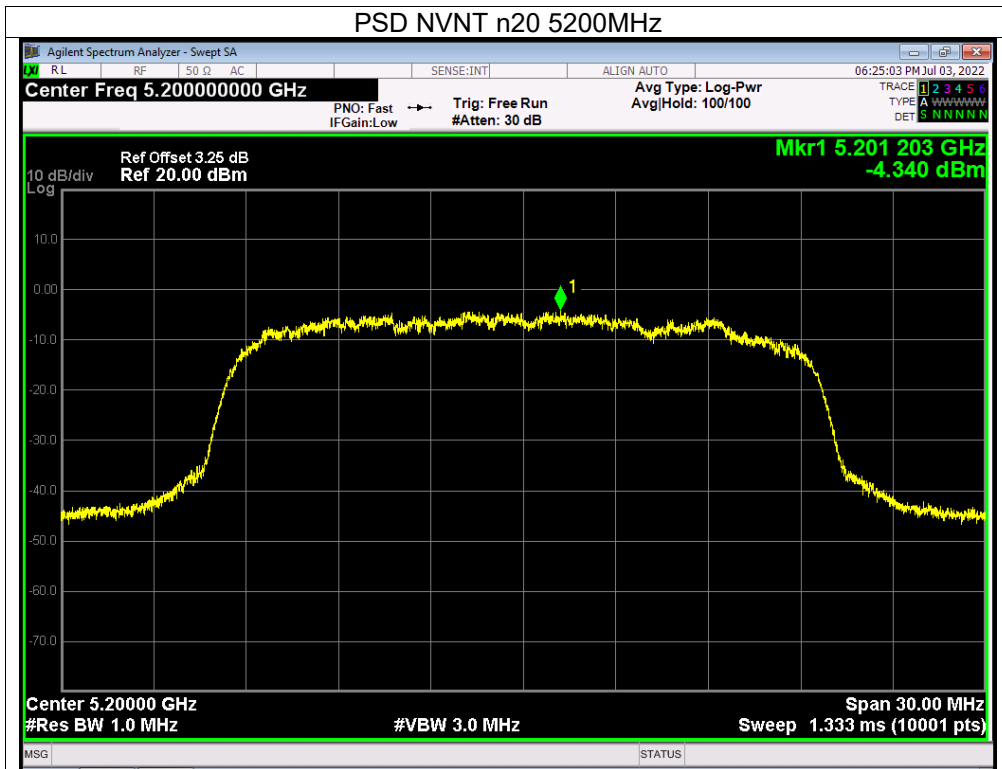

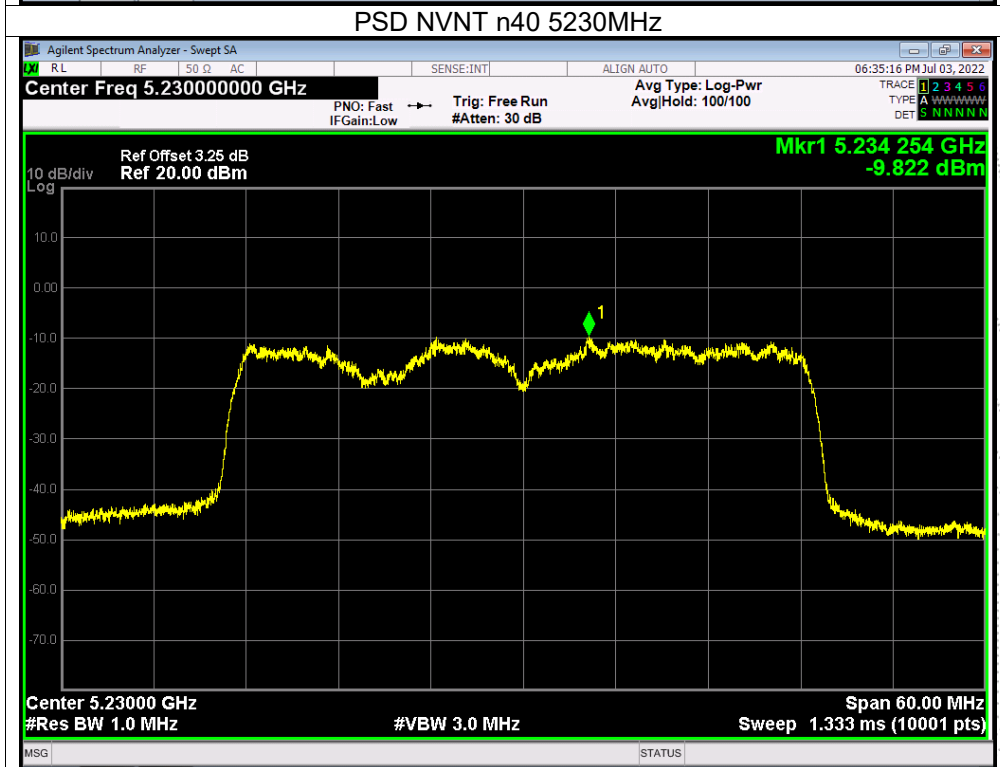
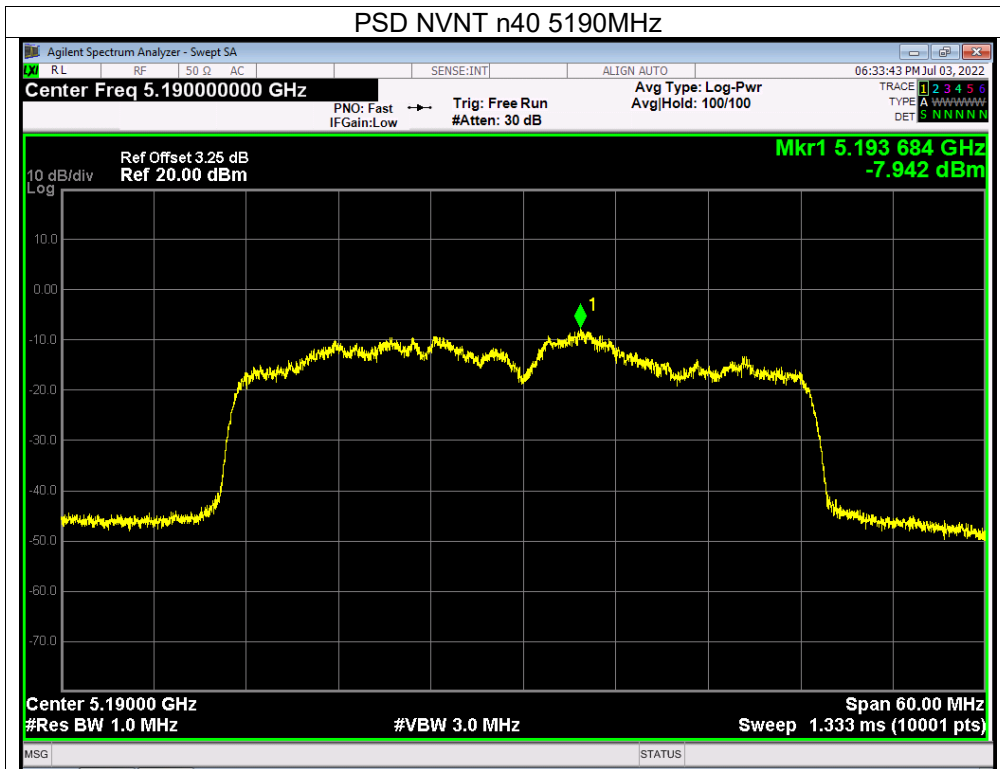

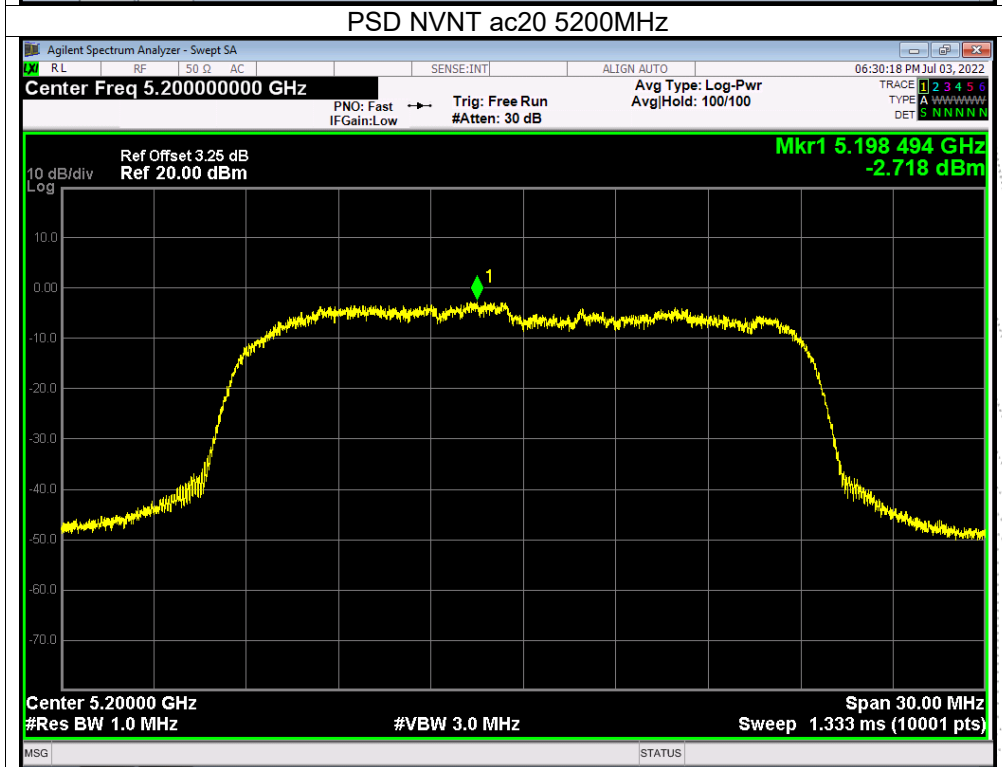
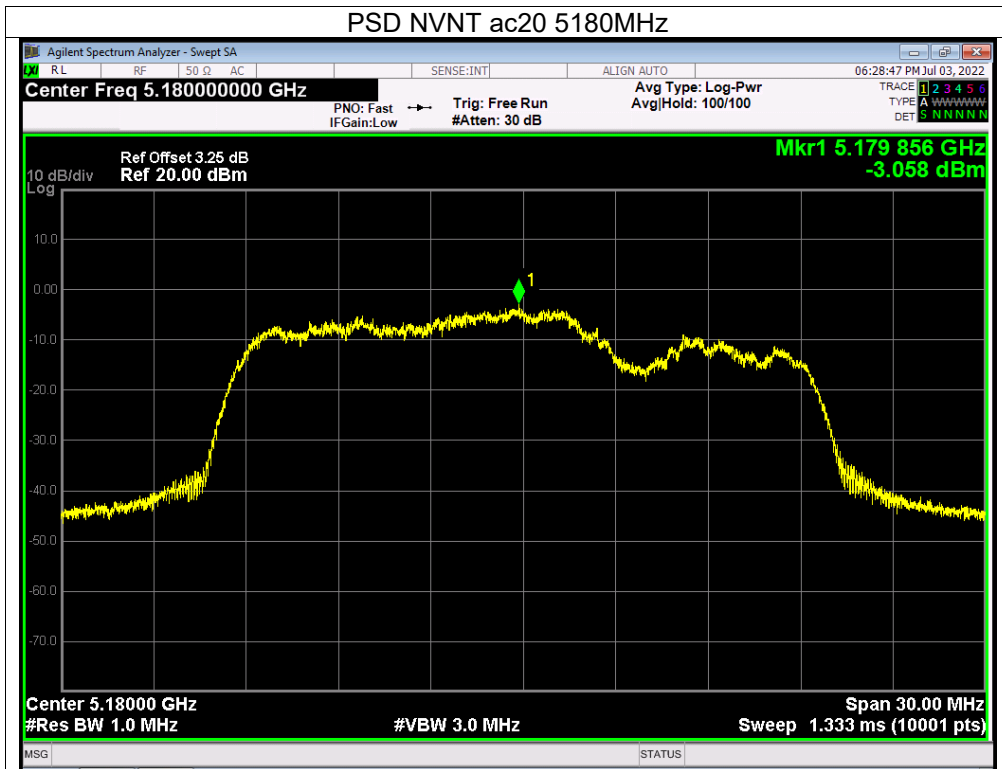

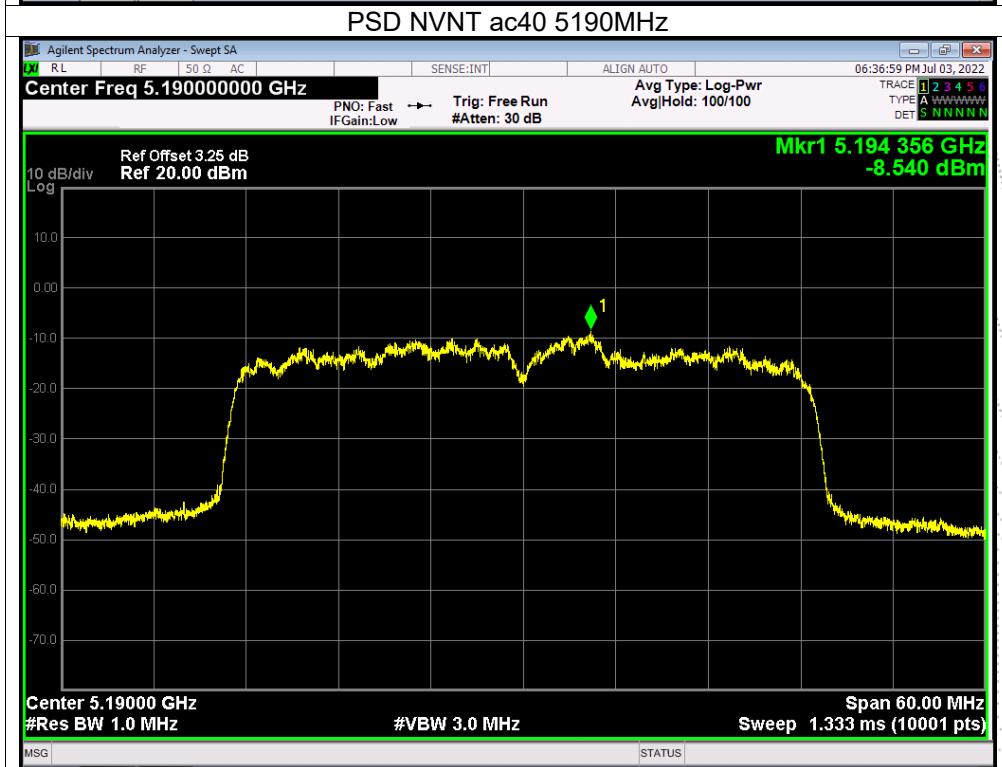
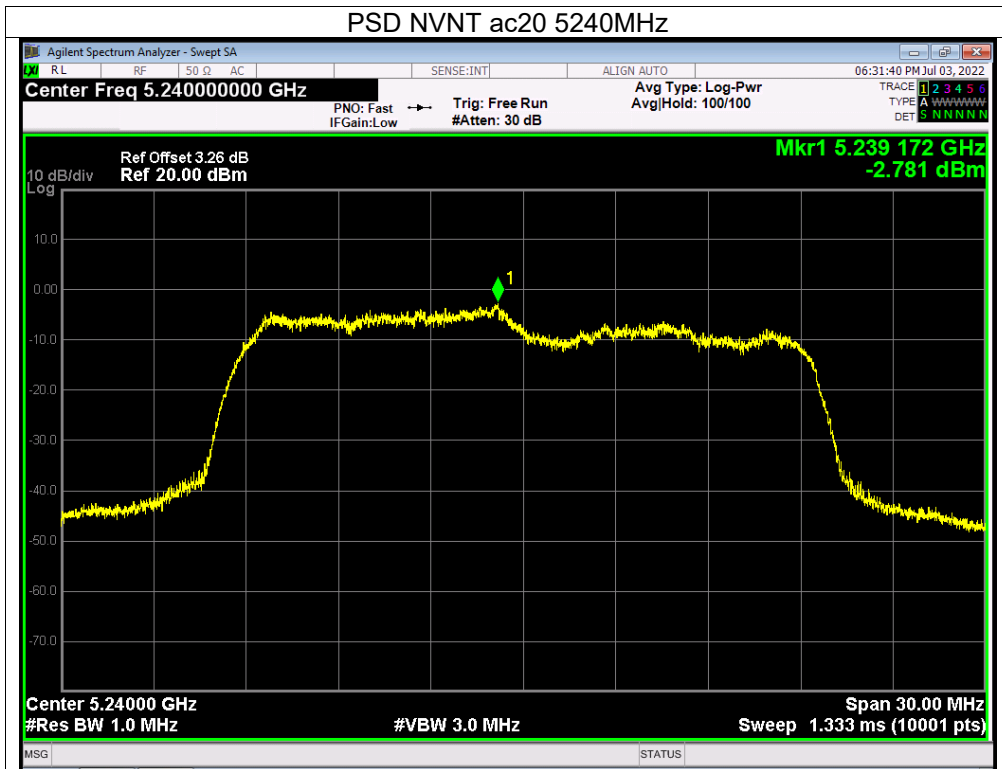

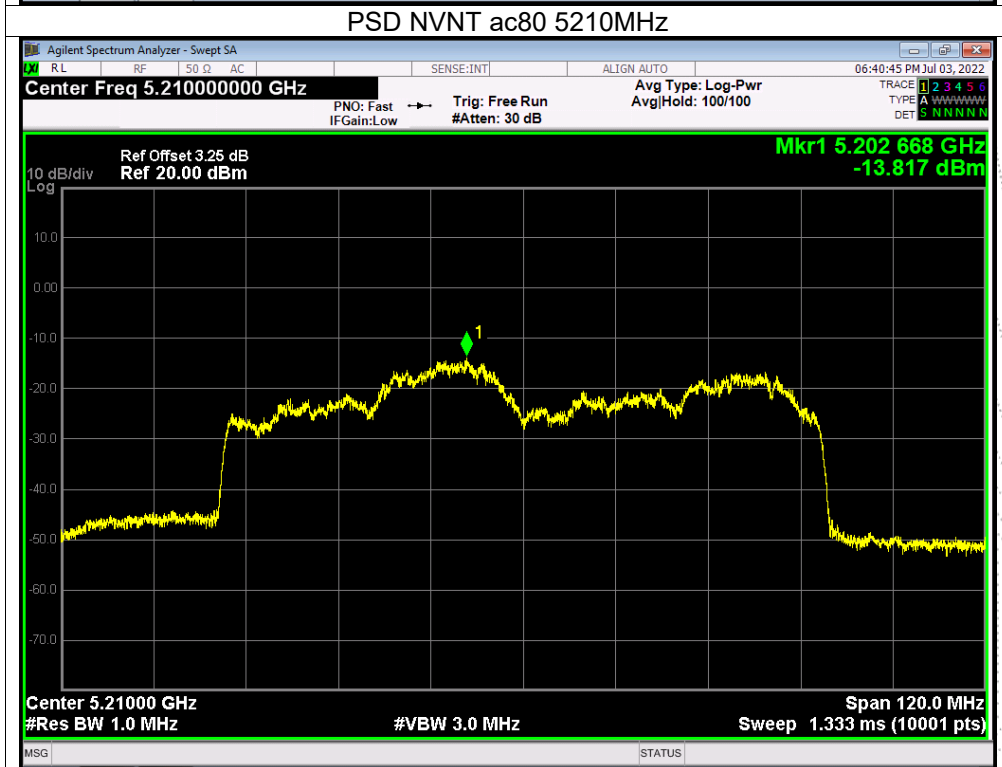
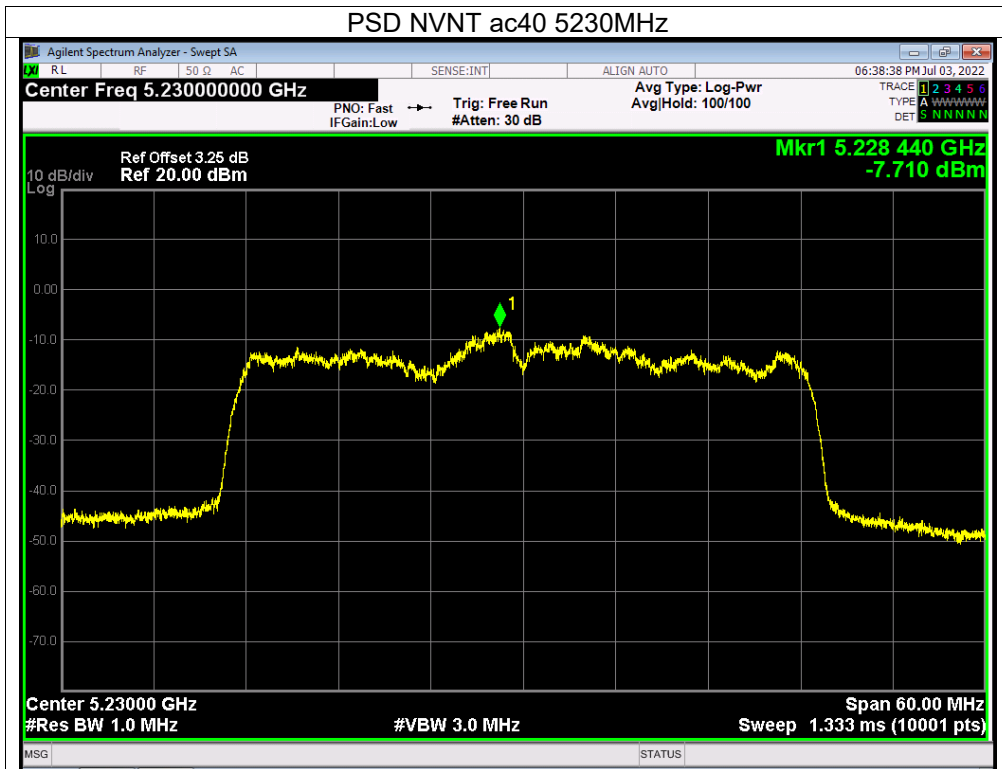

## 9. 26dB & 99% Emission Bandwidth

### 9.1 Block Diagram Of Test Setup

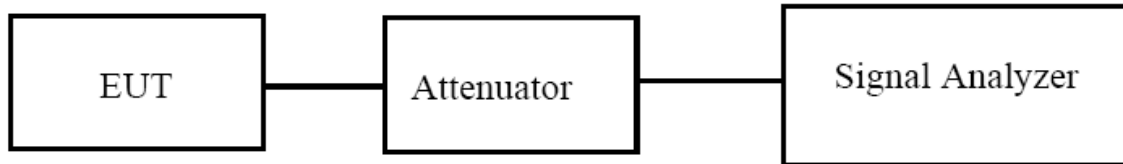

### 9.2 Limit

The maximum power spectral density is measured as a conducted emission by direct connection of a calibrated test instrument to the equipment under test. If the device cannot be connected directly, alternative techniques acceptable to the Commission may be used. Measurements in the 5.725-5.85 GHz band are made over a reference bandwidth of 500 kHz or the 26 dB emission bandwidth of the device, whichever is less. Measurements in the 5.15-5.25 GHz, 5.25-5.35 GHz, and the 5.47-5.725 GHz bands are made over a bandwidth of 1 MHz or the 26 dB emission bandwidth of the device, whichever is less. A narrower resolution bandwidth can be used, provided that the measured power is integrated over the full reference bandwidth.

### 9.3 Test Procedure

- a) Set RBW = approximately 1% of the emission bandwidth.
  - b) Set the VBW > RBW.
  - c) Detector = Peak.
  - d) Trace mode = max hold.
  - e) Measure the maximum width of the emission that is 26 dB down from the maximum of the emission. Compare this with the RBW setting of the analyzer. Readjust RBW and repeat measurement as needed until the RBW/EBW ratio is approximately 1%.
- The following procedure shall be used for measuring (99 %) power bandwidth:
1. Set center frequency to the nominal EUT channel center frequency.
  2. Set span = 1.5 times to 5.0 times the OBW.
  3. Set RBW = 1 % to 5 % of the OBW
  4. Set VBW  $\geq 3 \cdot$  RBW
  5. Video averaging is not permitted. Where practical, a sample detection and single sweep mode shall be used. Otherwise, peak detection and max hold mode (until the trace stabilizes) shall be used.
  6. Use the 99 % power bandwidth function of the instrument (if available).
  7. If the instrument does not have a 99 % power bandwidth function, the trace data points are recovered and directly summed in power units. The recovered amplitude data points, beginning at the lowest frequency, are placed in a running sum until 0.5 % of the total is reached; that frequency is recorded as the lower frequency. The process is repeated until 99.5 % of the total is reached; that frequency is recorded as the upper frequency. The 99% occupied bandwidth is the difference between these two frequencies.

## 9.4 EUT Operating Conditions

The EUT was configured for testing in a typical fashion (as a customer would normally use it). The EUT has been programmed to continuously transmit during test. This operating condition was tested and used to collect the included data.

## 9.5 Test Result

Temperature :	26 °C	Relative Humidity :	54%
Pressure :	101kPa	Test Voltage :	DC 5V from adapter
Test Mode :	TX Frequency U-NII-1 (5180-5240MHz)		

Mode	Channel	Frequency (MHz)	99% bandwidth(MHz)	26dB bandwidth(MHz)	Result
802.11a	CH36	5180	16.547	21.316	Pass
	CH40	5200	16.571	21.284	Pass
	CH48	5240	16.55	21.211	Pass
802.11 n20	CH36	5180	17.711	21.477	Pass
	CH40	5200	17.717	21.385	Pass
	CH48	5240	17.736	21.524	Pass
802.11 n40	CH 38	5190	36.183	40.397	Pass
	CH 46	5230	36.177	40.584	Pass
802.11 AC20	CH36	5180	17.73	21.715	Pass
	CH40	5200	17.696	21.414	Pass
	CH48	5240	17.744	21.392	Pass
802.11 AC40	CH 38	5190	36.153	40.323	Pass
	CH 46	5230	36.189	40.454	Pass
802.11 AC80	CH 42	5210	75.477	81.196	Pass

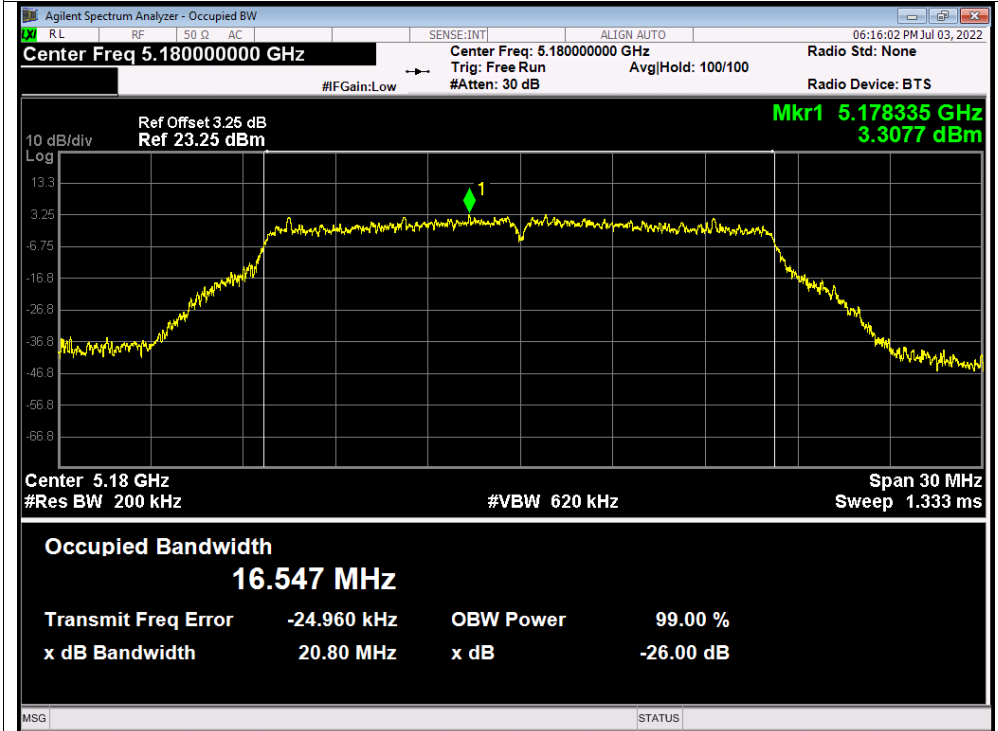
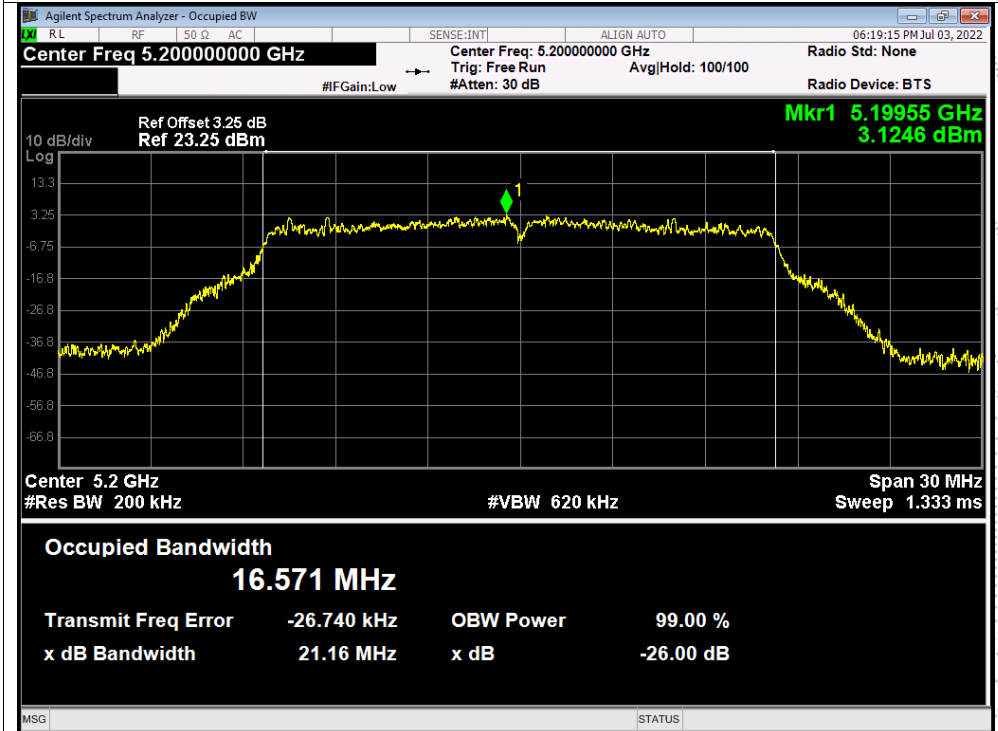
**99% OBW**
**Test Graphs**
**OBW NVNT a 5180MHz**

**OBW NVNT a 5200MHz**

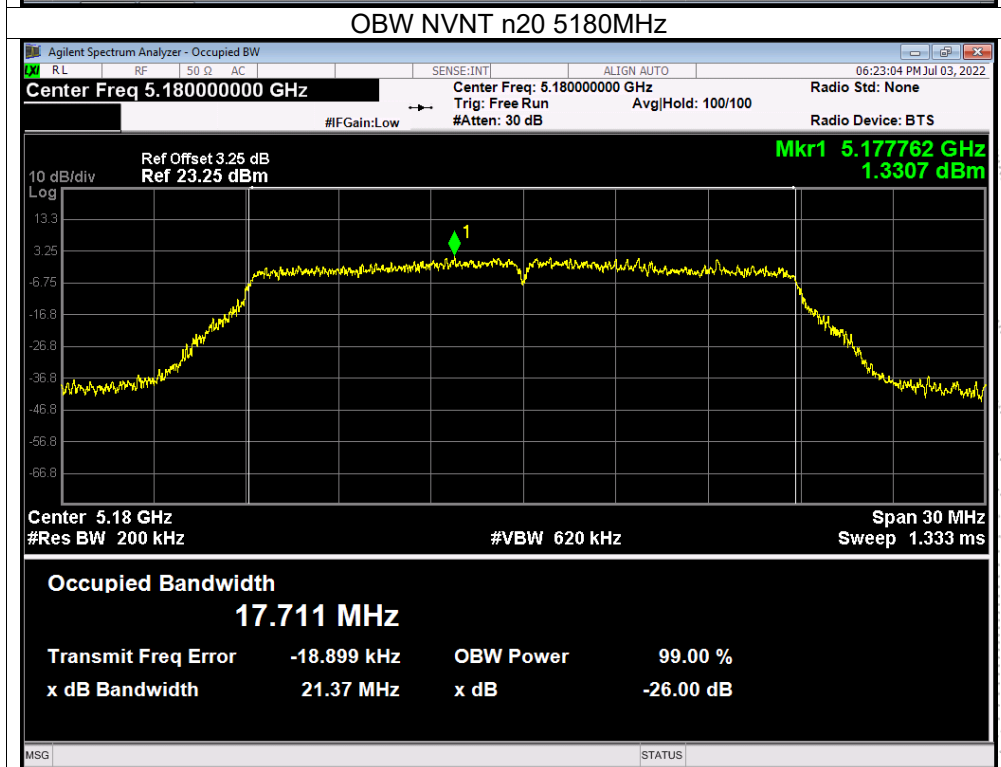
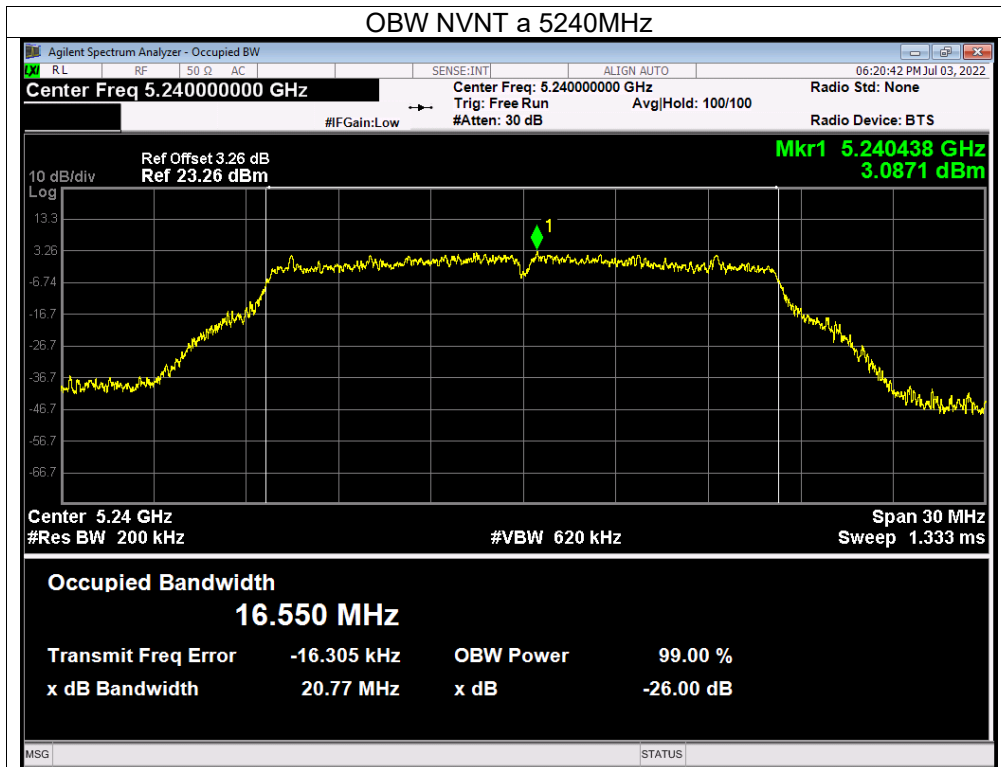

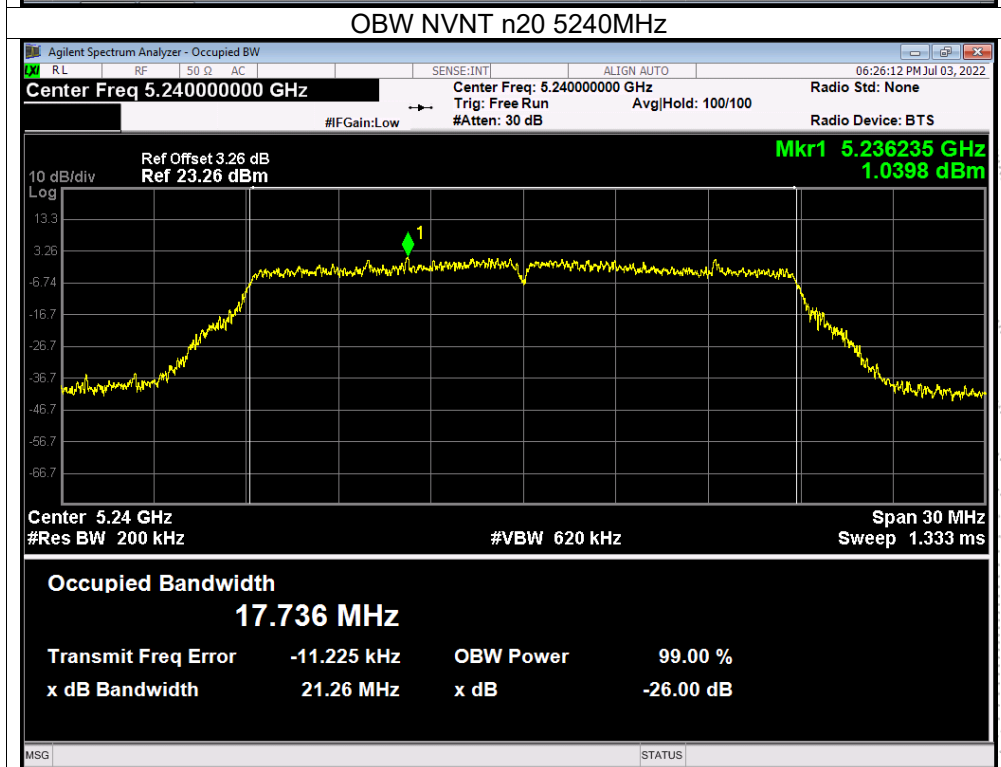
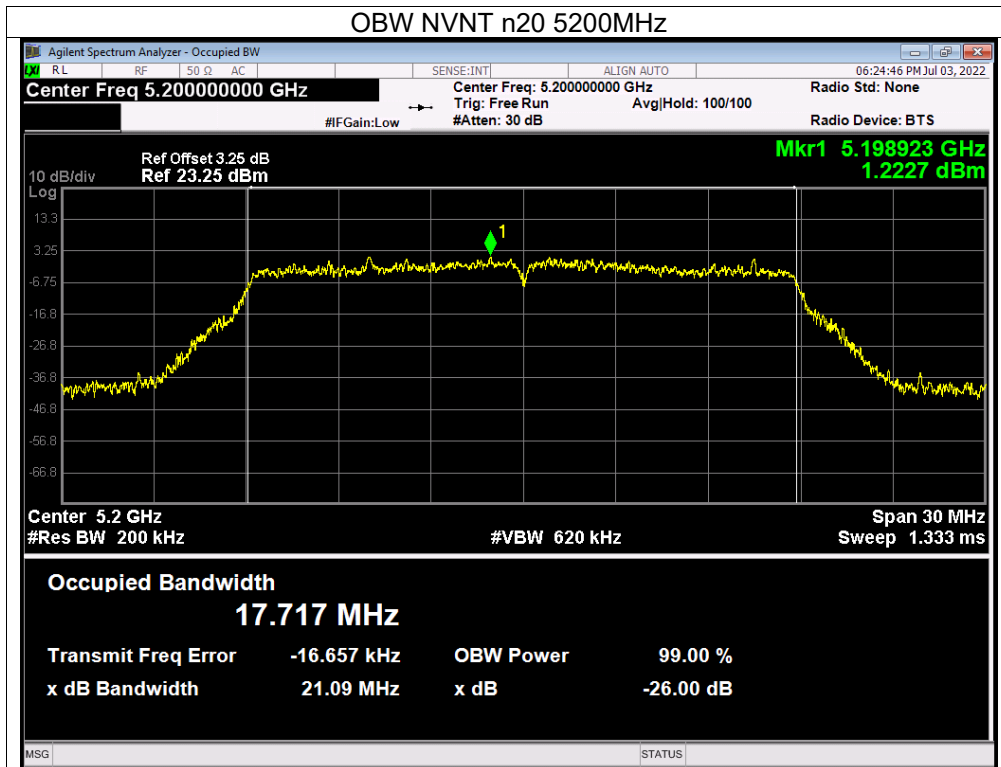

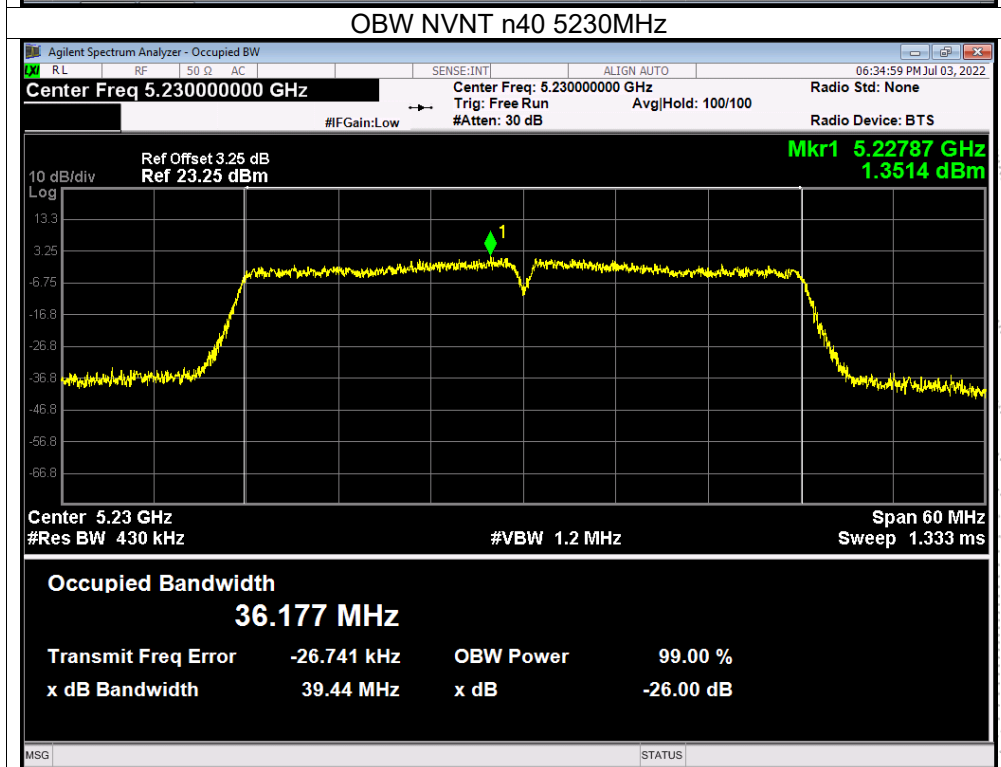
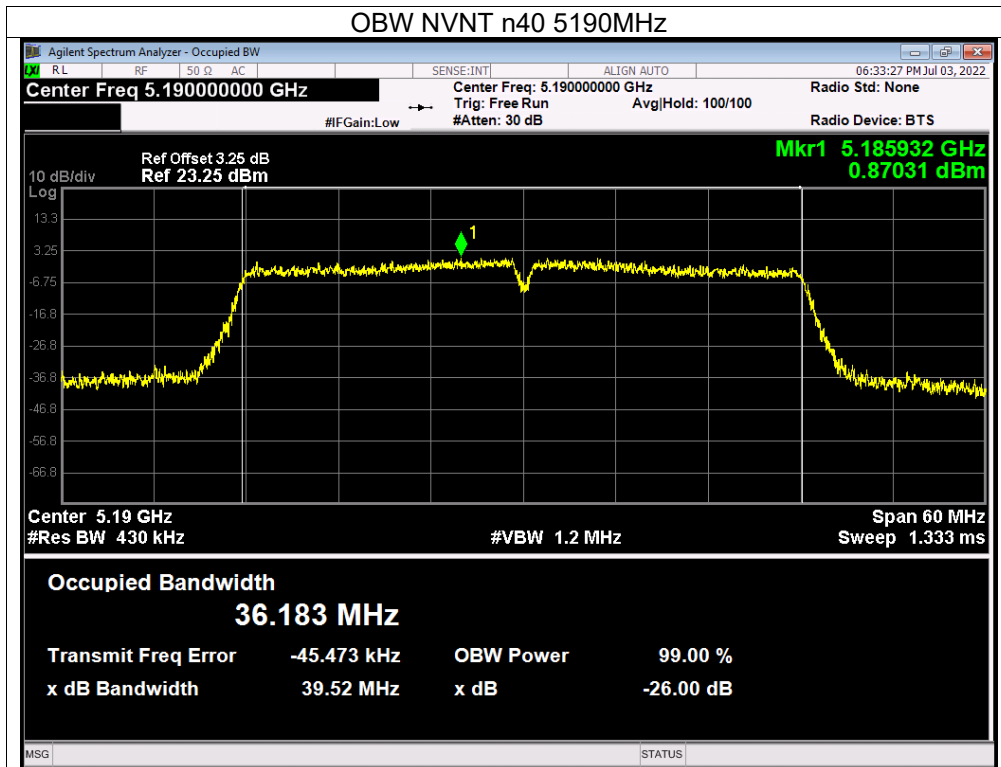

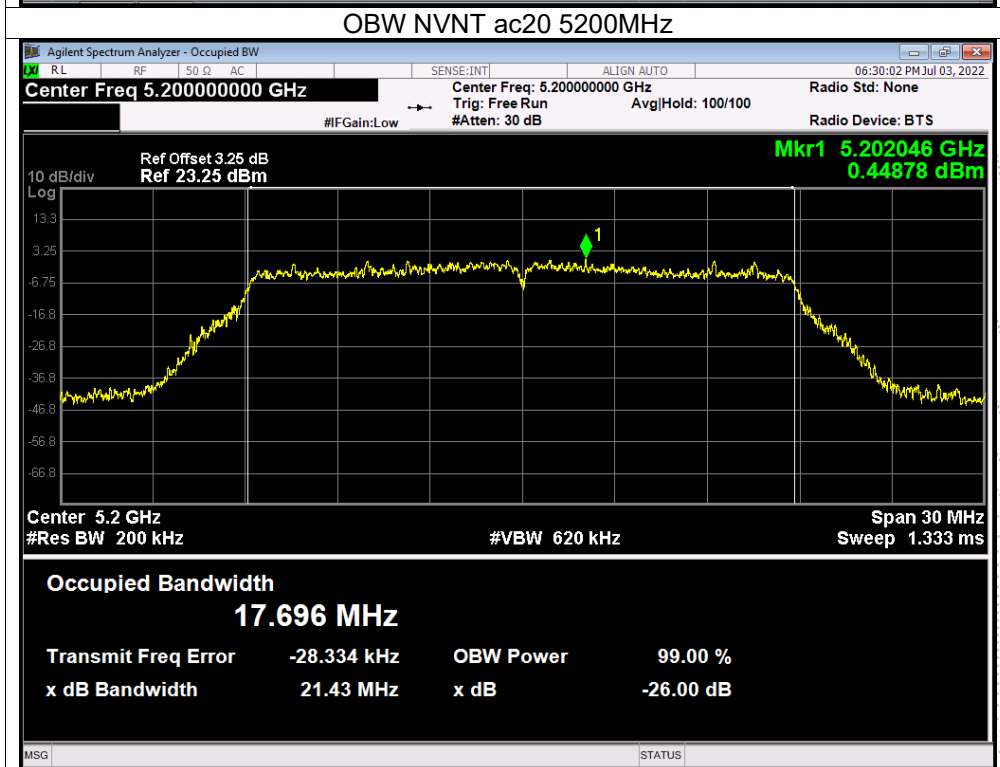
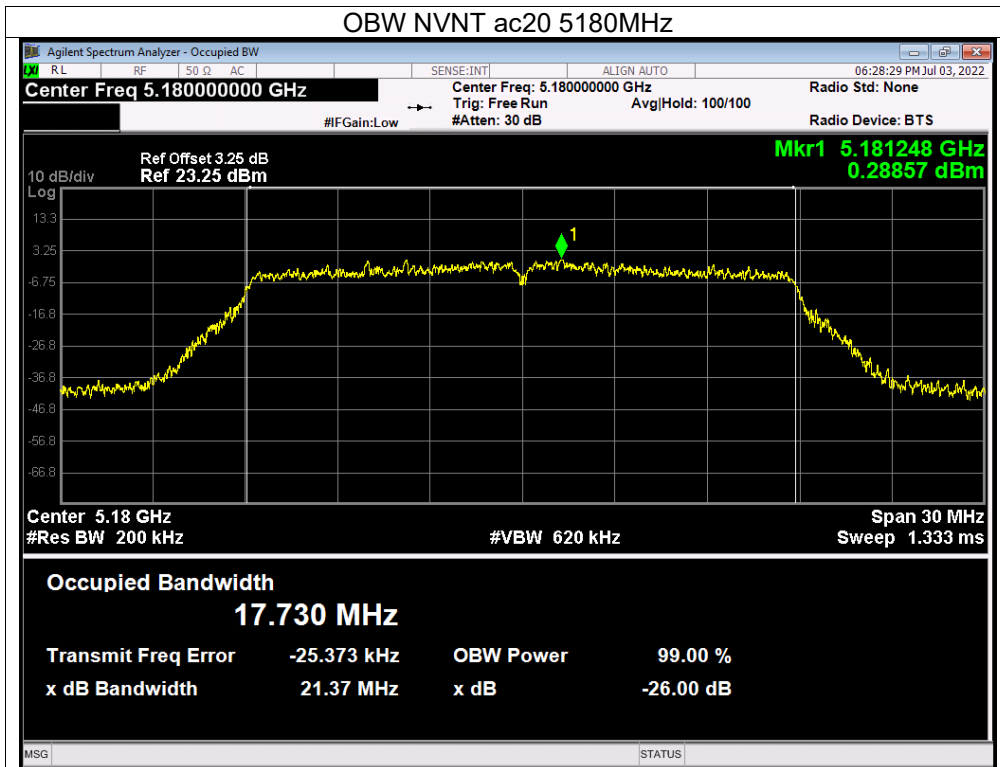



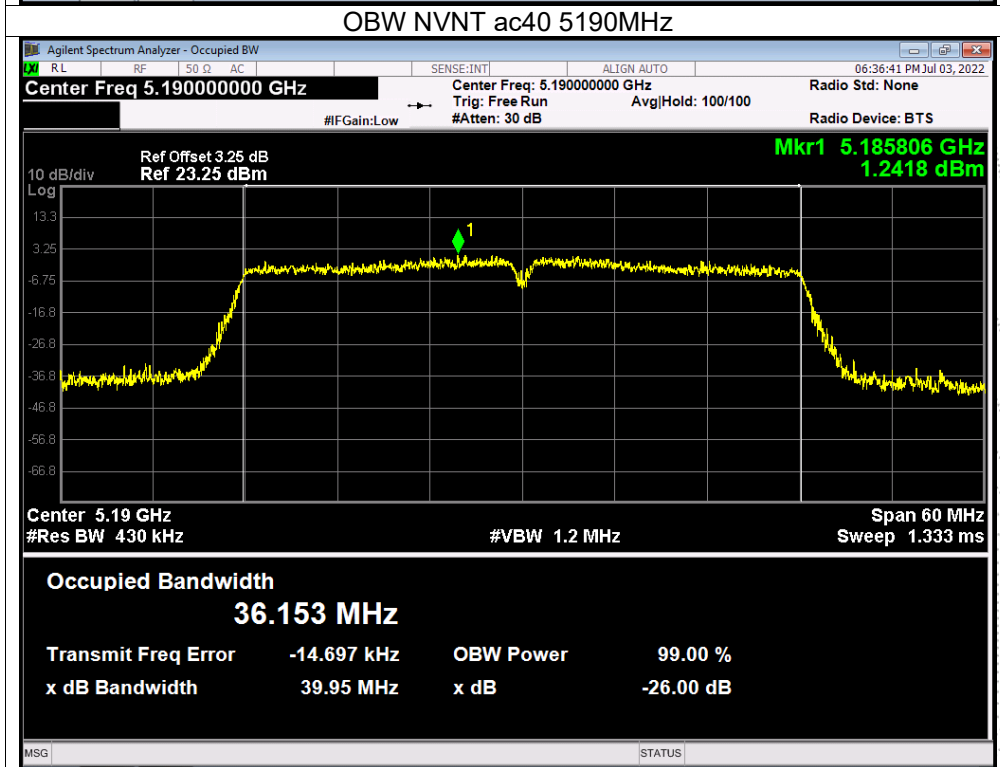
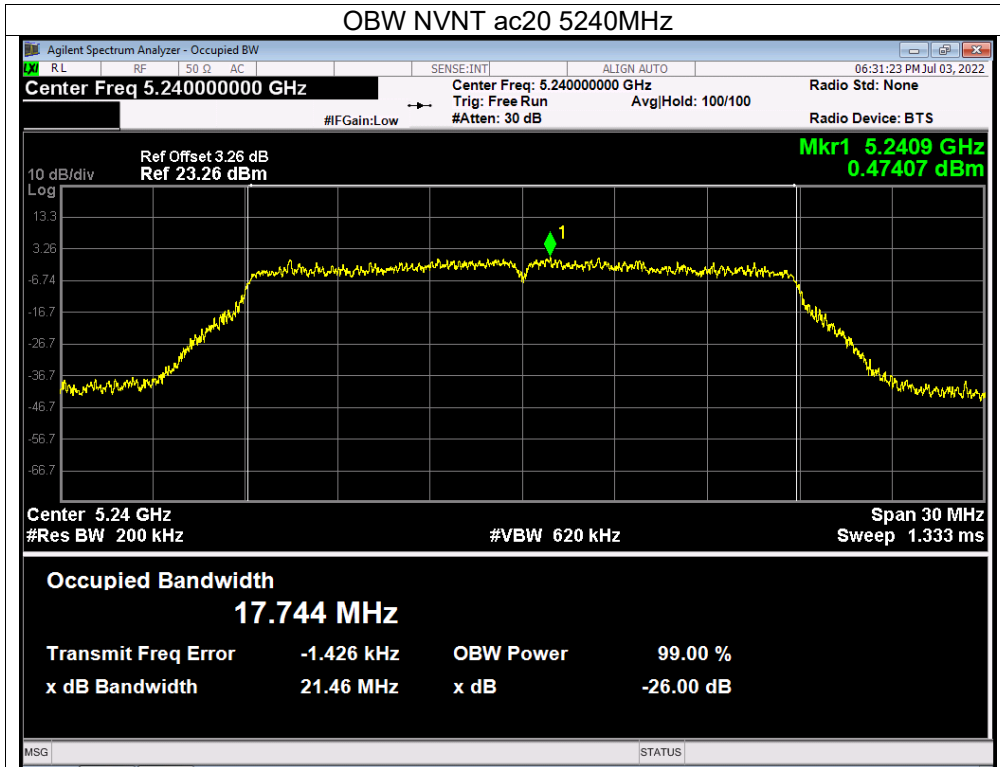

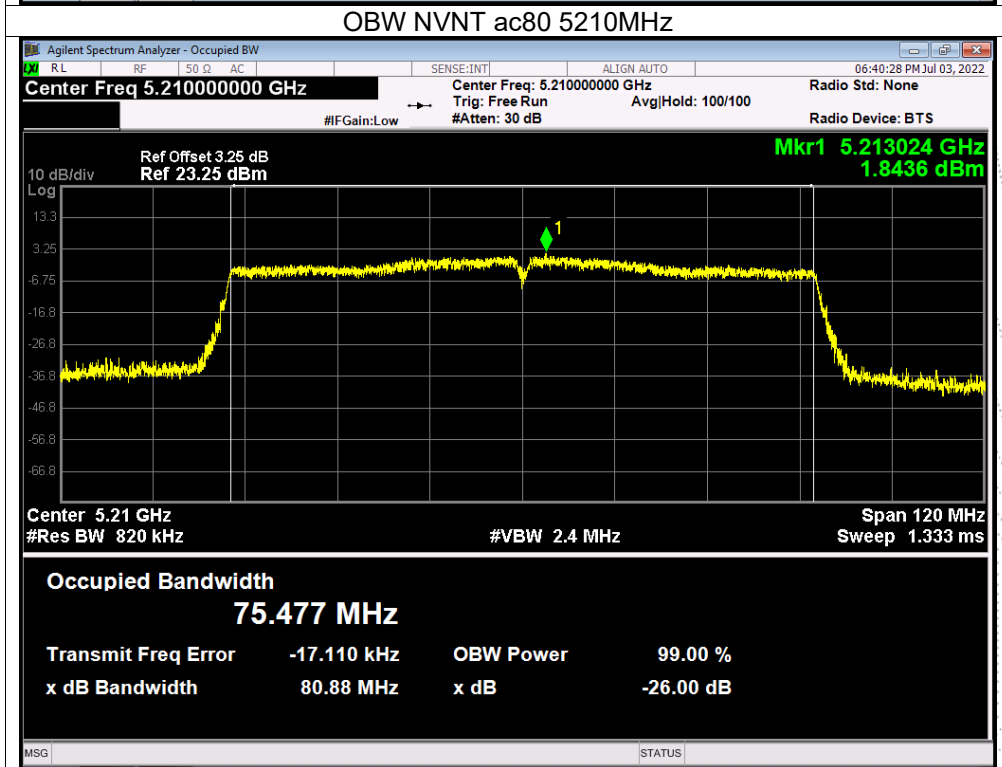
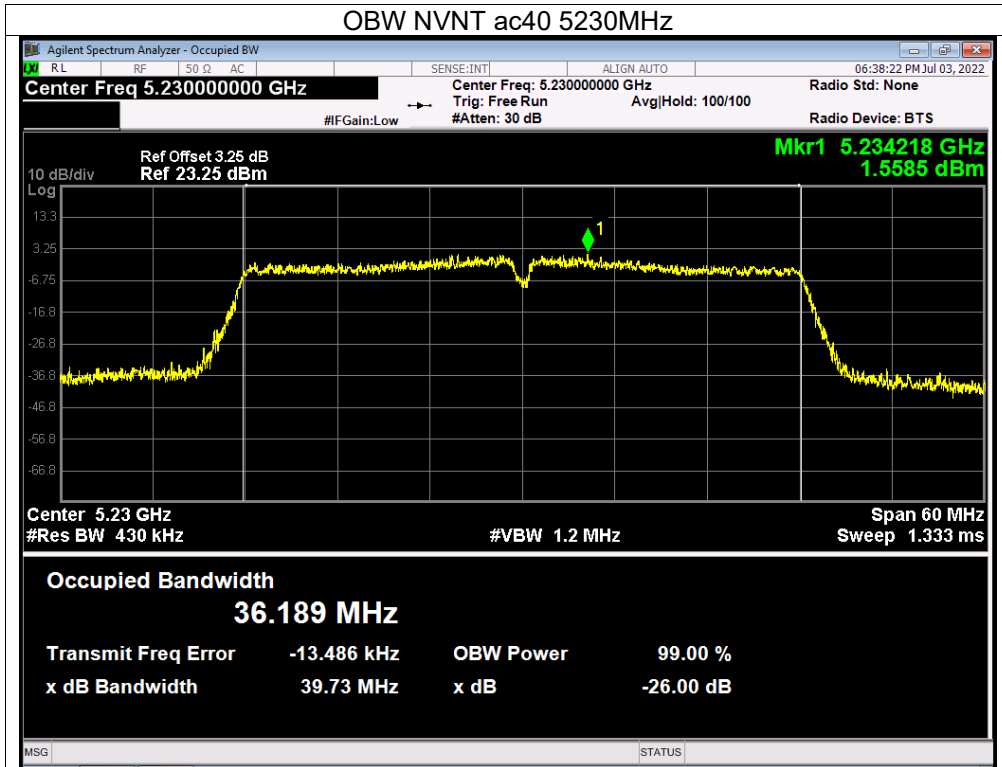

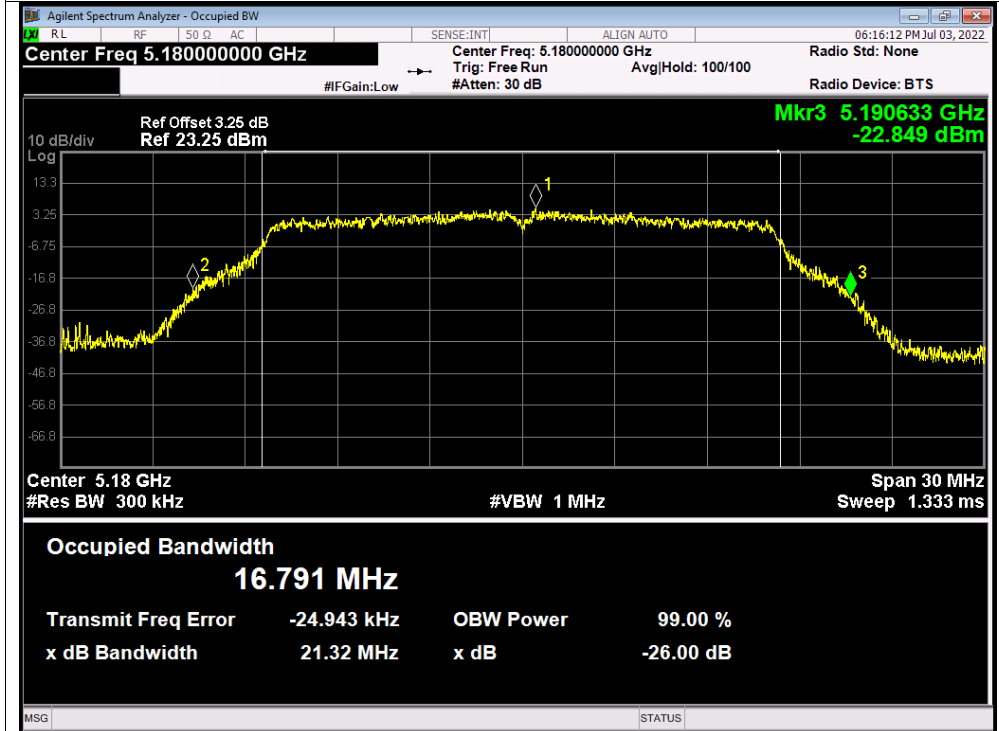
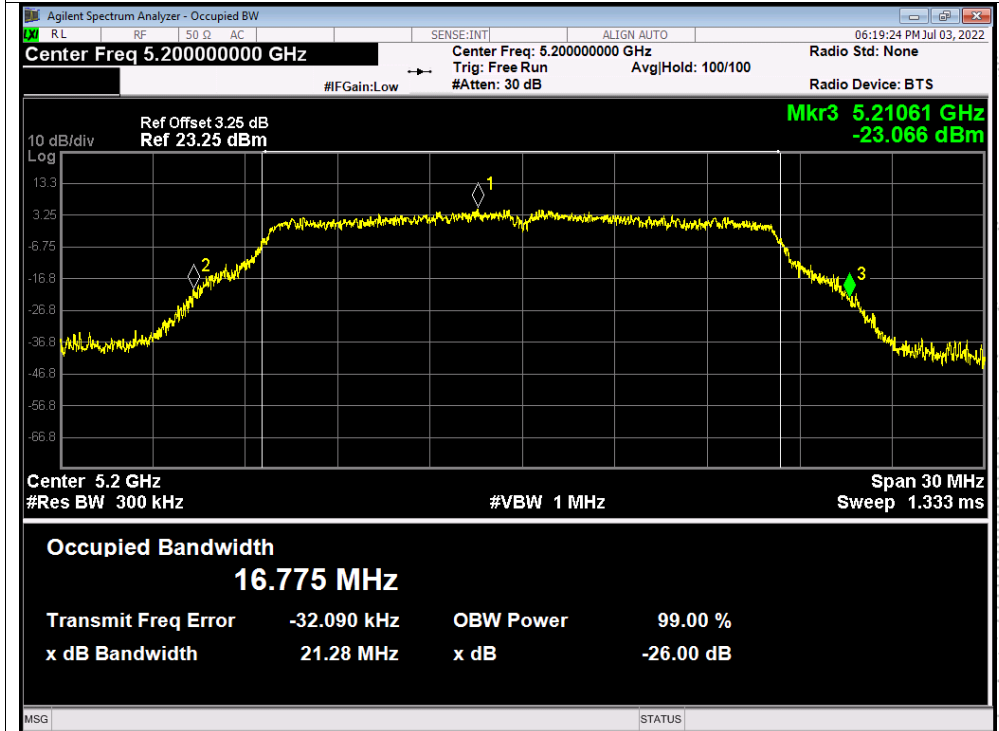
**-26dB Bandwidth**
**Test Graphs**
**-26dB Bandwidth NVNT a 5180MHz**

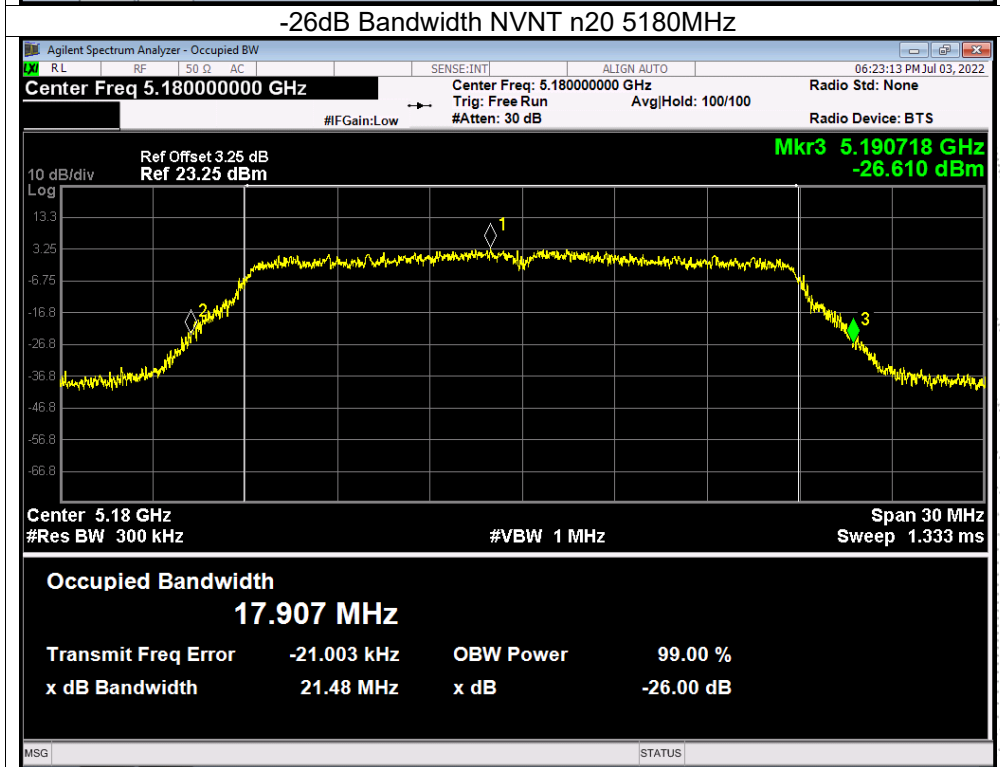
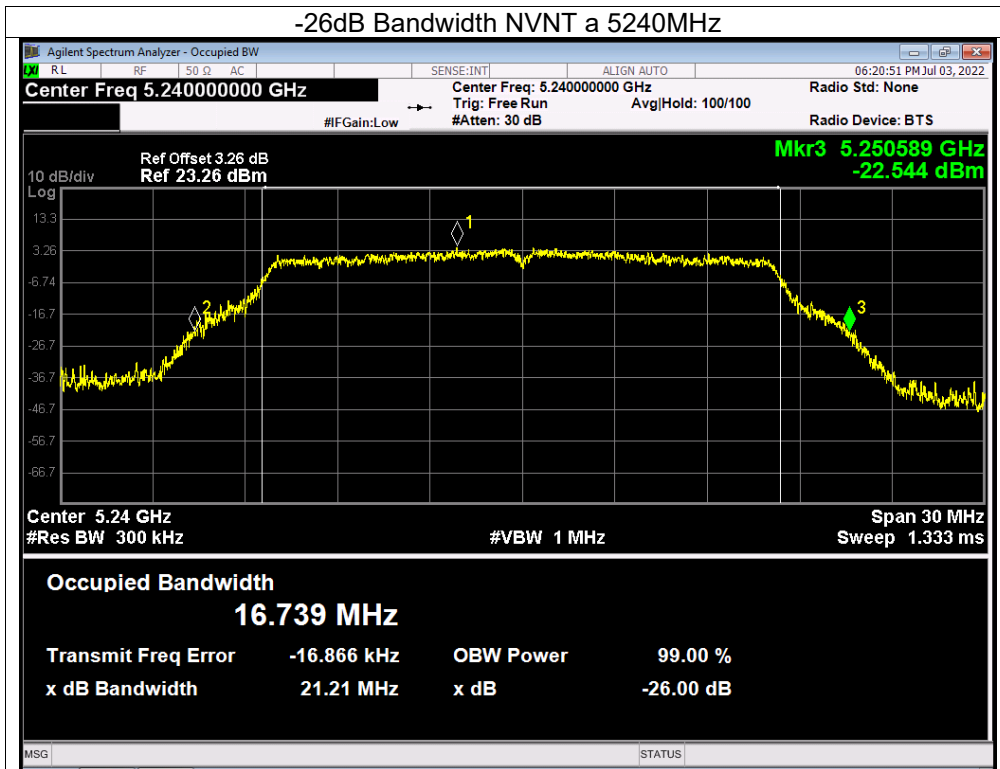
**-26dB Bandwidth NVNT a 5200MHz**



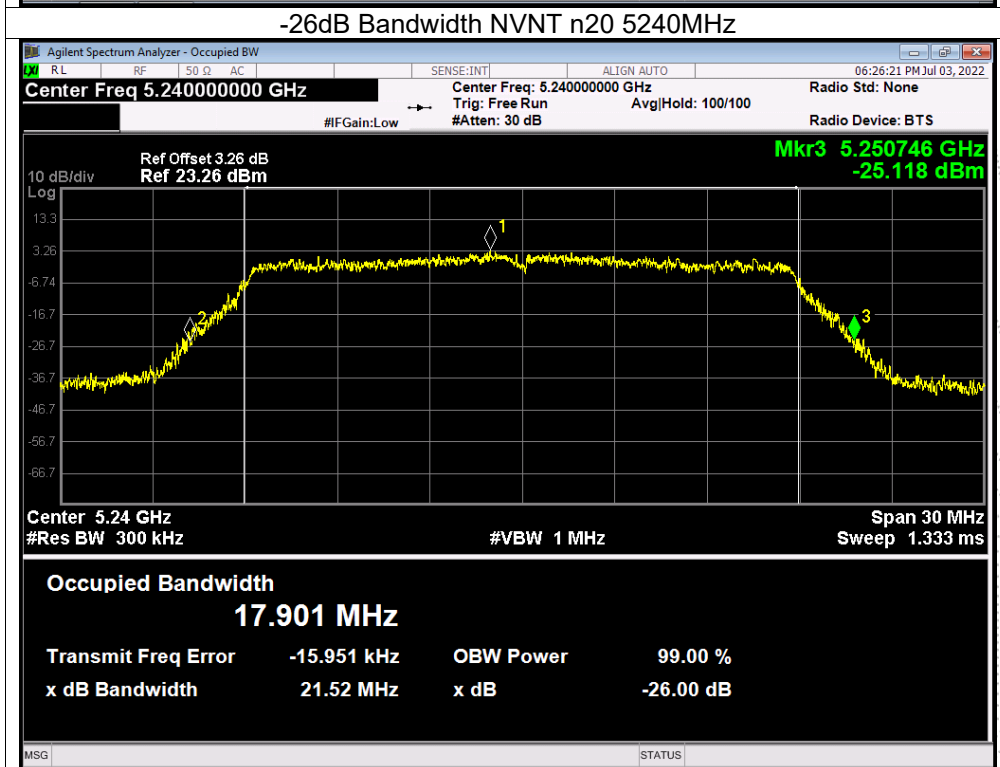
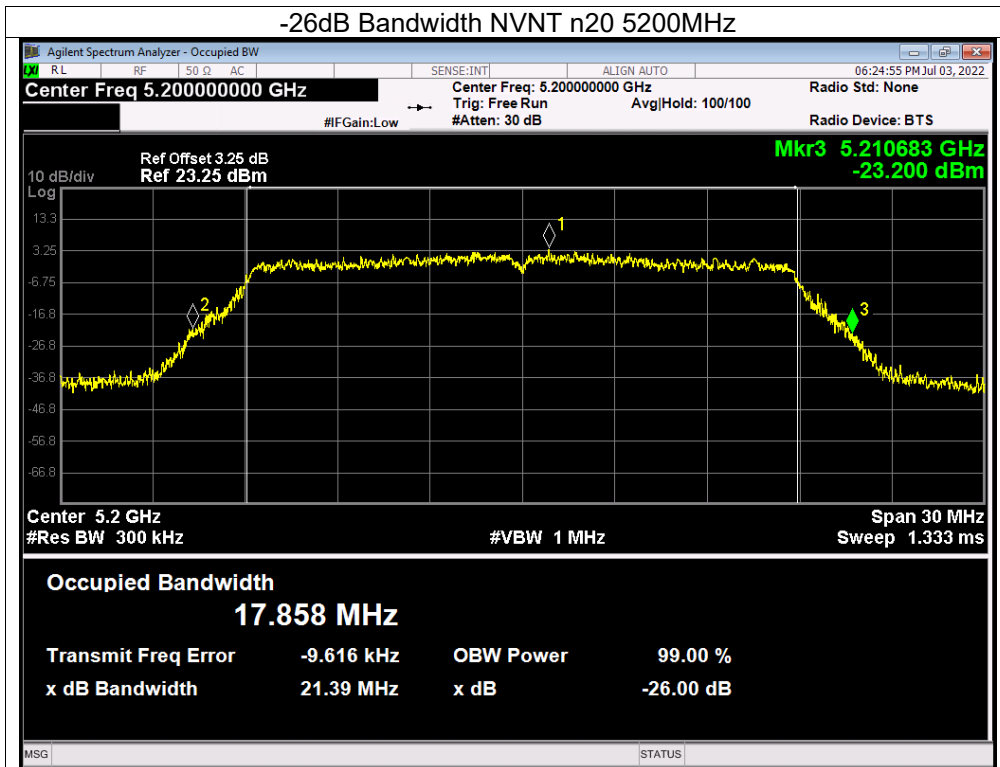

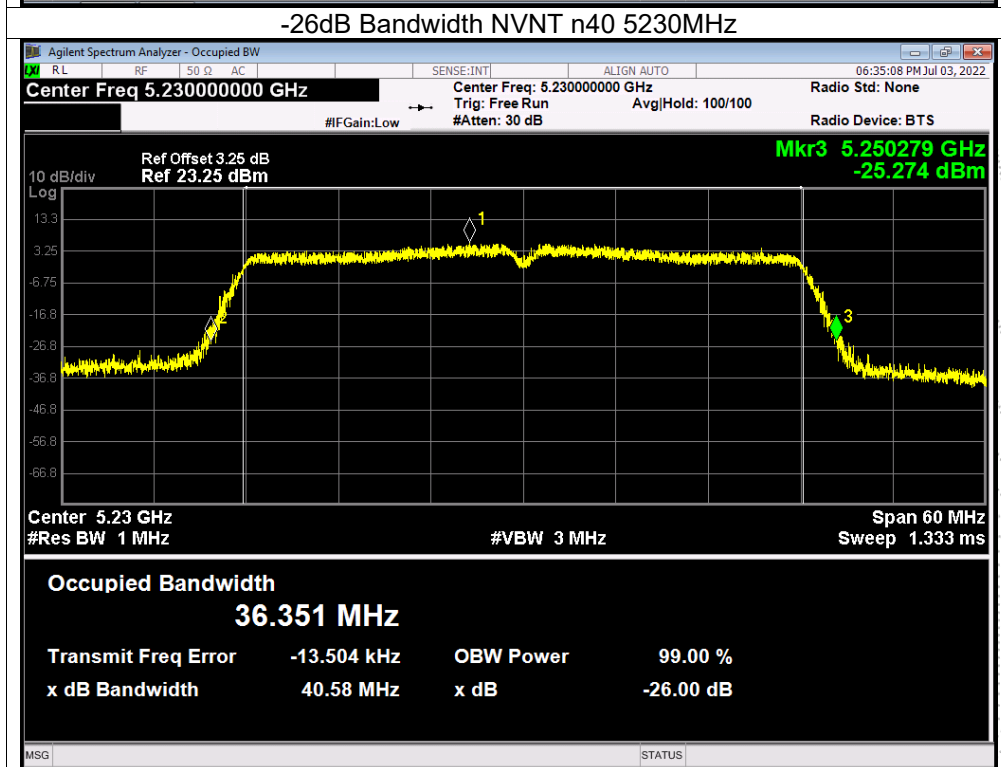
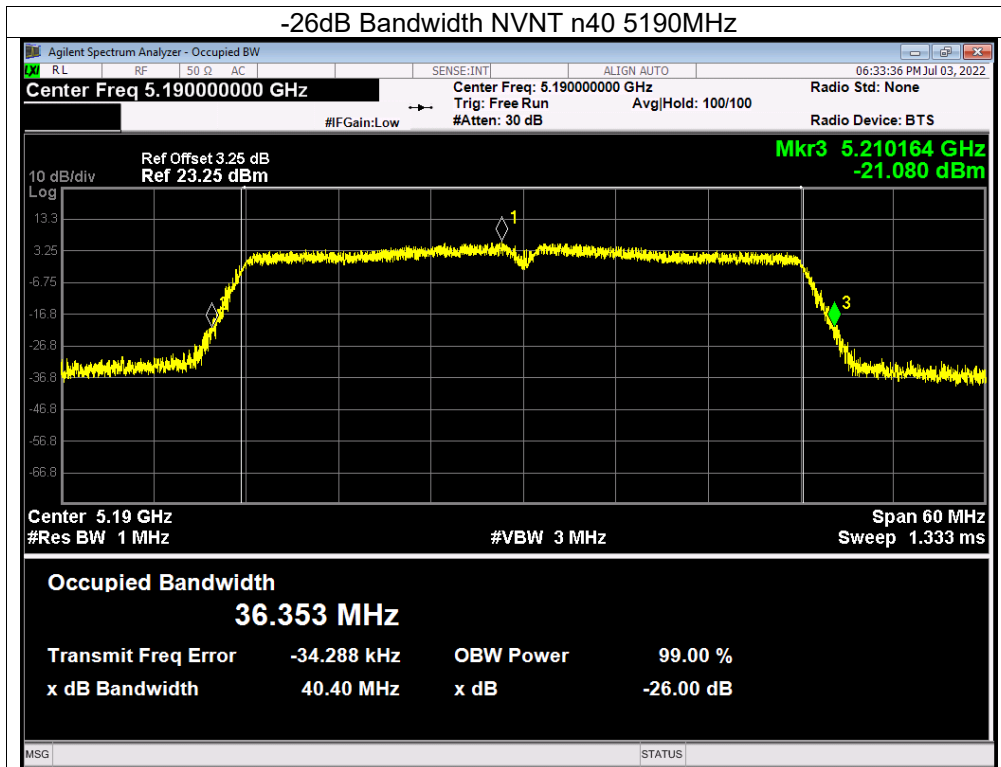

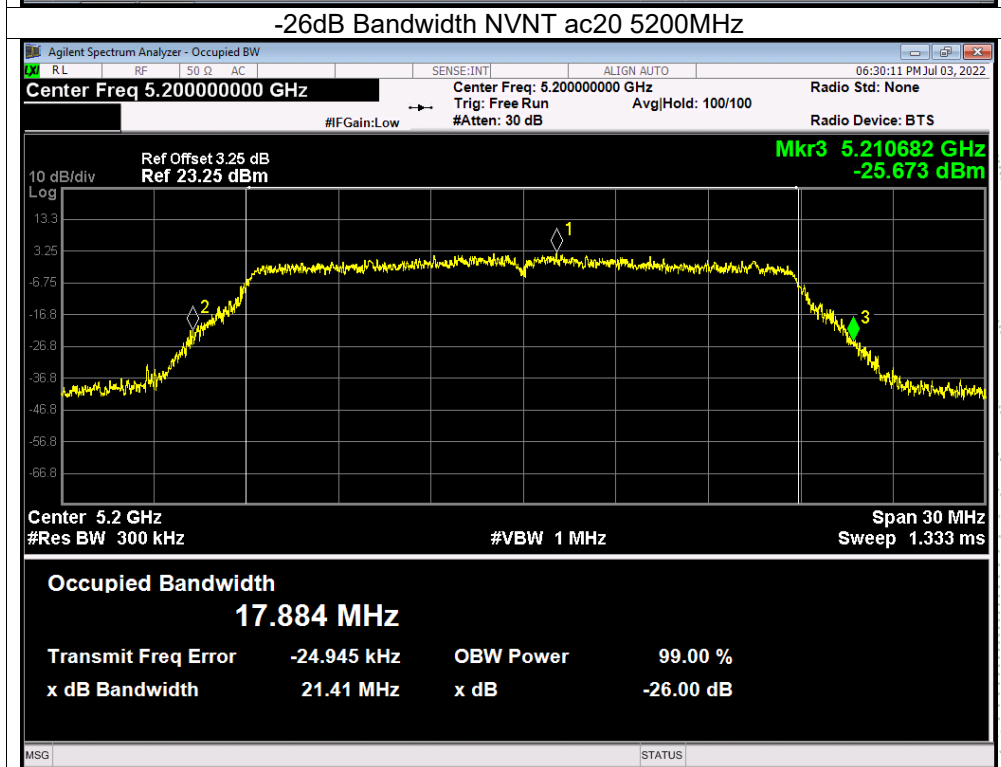
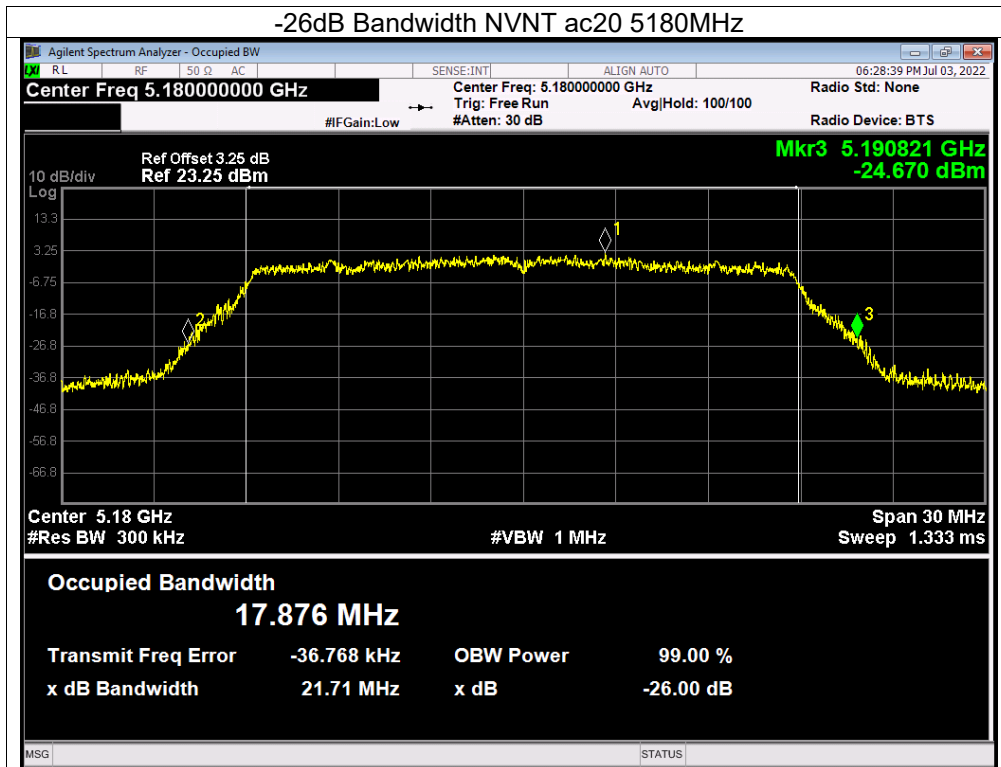



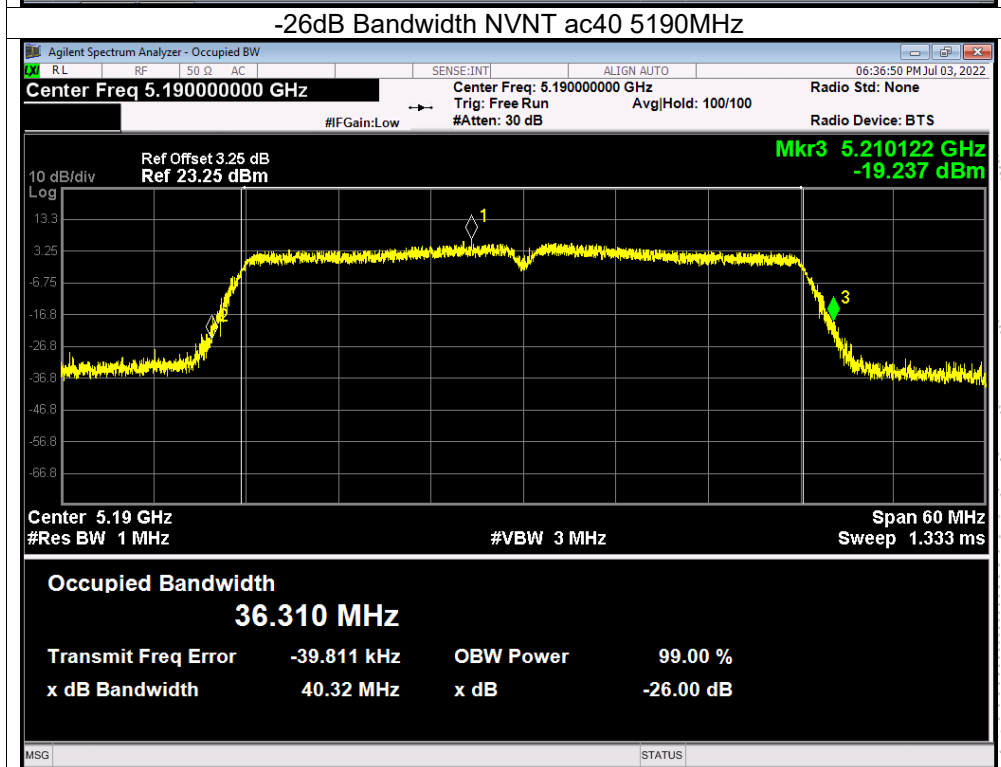
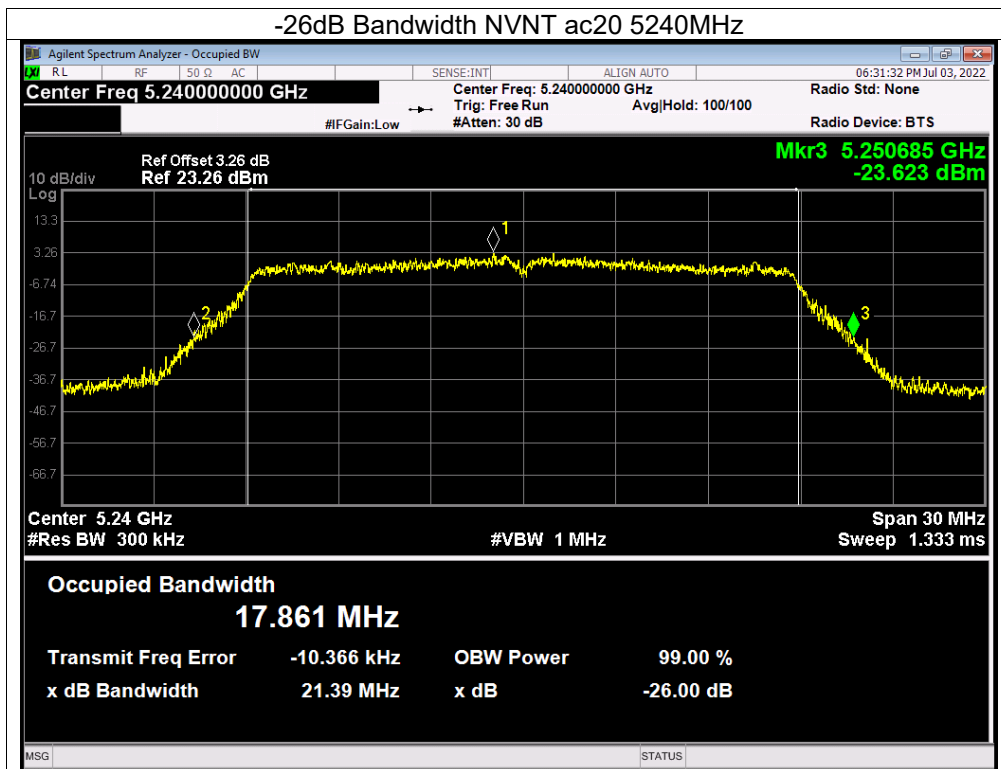

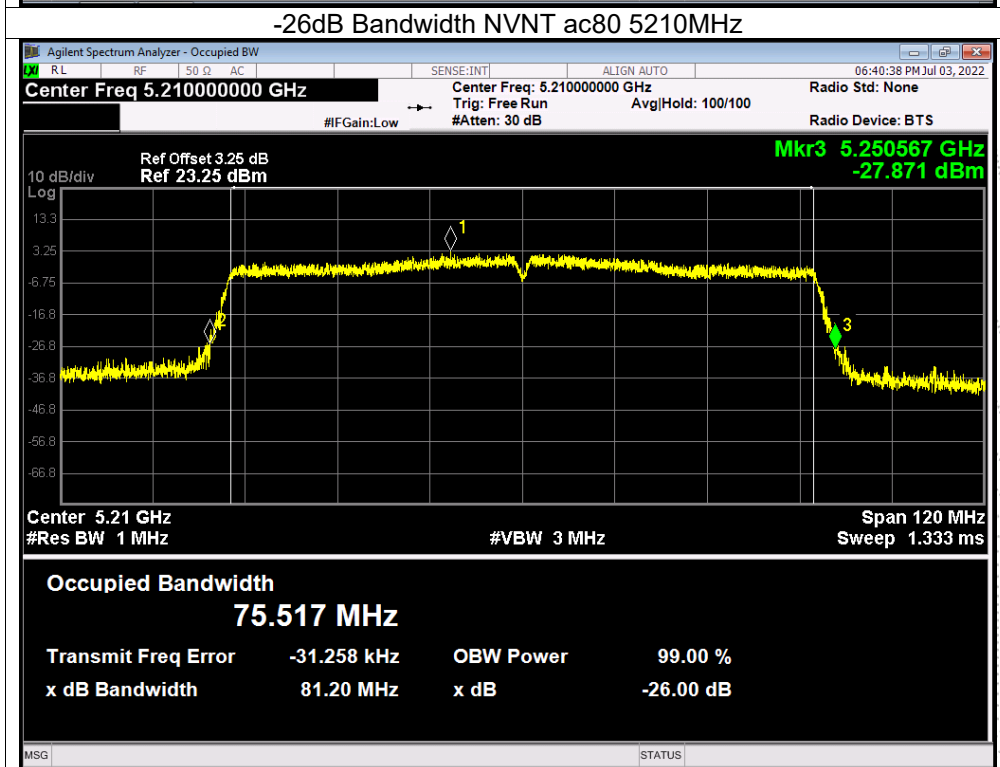
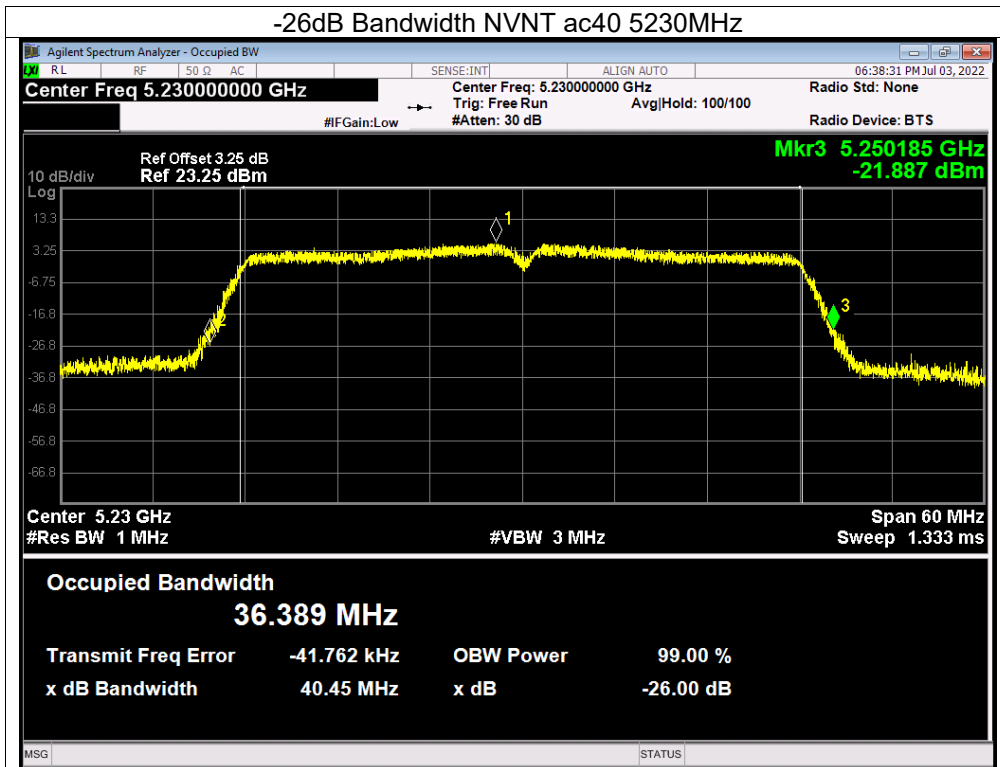

## 10. Maximum Conducted Output Power

### 10.1 Block Diagram Of Test Setup

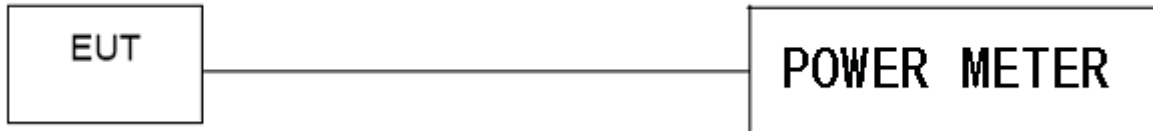

### 10.2 Limit

#### According to FCC §15.407

The maximum conducted output power should not exceed:

Frequency Band(MHz)	Limit
5150~5250	1W
5725~5850	1W

### 10.3 Test Procedure

Maximum conducted output power may be measured using a spectrum analyzer/EMI receiver or an RF power meter.

#### 1. Device Configuration

If possible, configure or modify the operation of the EUT so that it transmits continuously at its maximum power control level (see section II.B.).

a) The intent is to test at 100 percent duty cycle; however a small reduction in duty cycle (to no lower than 98 percent) is permitted if required by the EUT for amplitude control purposes. Manufacturers are expected to provide software to the test lab to permit such continuous operation.

b) If continuous transmission (or at least 98 percent duty cycle) cannot be achieved due to hardware limitations (e.g., overheating), the EUT shall be operated at its maximum power control level with the transmit duration as long as possible and the duty cycle as high as possible.

#### 2. Measurement using a Spectrum Analyzer or EMI Receiver (SA)

Measurement of maximum conducted output power using a spectrum analyzer requires integrating the spectrum across a frequency span that encompasses, at a minimum, either the EBW or the 99-percent occupied bandwidth of the signal. However, the EBW must be used to determine bandwidth dependent limits on maximum conducted output power in accordance with § 15.407(a).

a) The test method shall be selected as follows: (i) Method SA-1 or SA-1 Alternative (averaging with the EUT transmitting at full power throughout each sweep) shall be applied if either of the following conditions can be satisfied:

- The EUT transmits continuously (or with a duty cycle  $\geq 98$  percent).

- Sweep triggering or gating can be implemented in a way that the device transmits at the maximum power control level throughout the duration of each of the instrument sweeps to be averaged. This condition can generally be achieved by triggering the instrument's sweep if the duration of the sweep (with the analyzer configured as in Method SA-1, below) is equal to or shorter than the duration T of each transmission from the EUT and if those transmissions exhibit full power throughout their durations.

(ii) Method SA-2 or SA-2 Alternative (averaging across on and off times of the EUT transmissions, followed by duty cycle correction) shall be applied if the conditions of (i) cannot be achieved and the transmissions exhibit a constant duty cycle during the measurement duration. Duty cycle will be considered to be constant if variations are less than  $\pm 2$  percent.

(iii) Method SA-3 (RMS detection with max hold) or SA-3 Alternative (reduced VBW with max hold) shall be applied if the conditions of (i) and (ii) cannot be achieved.

b) Method SA-1 (trace averaging with the EUT transmitting at full power throughout each sweep): (i) Set span to encompass the entire emission bandwidth (EBW) (or, alternatively, the entire 99% occupied bandwidth) of the signal.

(ii) Set RBW = 1 MHz.

(iii) Set VBW  $\geq$  3 MHz.

(iv) Number of points in sweep  $\geq$  2 Span / RBW. (This ensures that bin-to-bin spacing is  $\leq$  RBW/2, so that narrowband signals are not lost between frequency bins.)

(v) Sweep time = auto.

(vi) Detector = RMS (i.e., power averaging), if available. Otherwise, use sample detector mode.

(vii) If transmit duty cycle < 98 percent, use a video trigger with the trigger level set to enable triggering only on full power pulses. Transmitter must operate at maximum power control level for the entire duration of every sweep. If the EUT transmits continuously (i.e., with no off intervals) or at duty cycle  $\geq$  98 percent, and if each transmission is entirely at the maximum power control level, then the trigger shall be set to "free run".

(viii) Trace average at least 100 traces in power averaging (i.e., RMS) mode.

(ix) Compute power by integrating the spectrum across the EBW (or, alternatively, the entire 99% occupied bandwidth) of the signal using the instrument's band power measurement function with band limits set equal to the EBW (or occupied bandwidth) band edges. If the instrument does not have a band power function, sum the spectrum

## 10.4 EUT Operating Conditions

The EUT was configured for testing in a typical fashion (as a customer would normally use it). The EUT has been programmed to continuously transmit during test. This operating condition was tested and used to collect the included data.

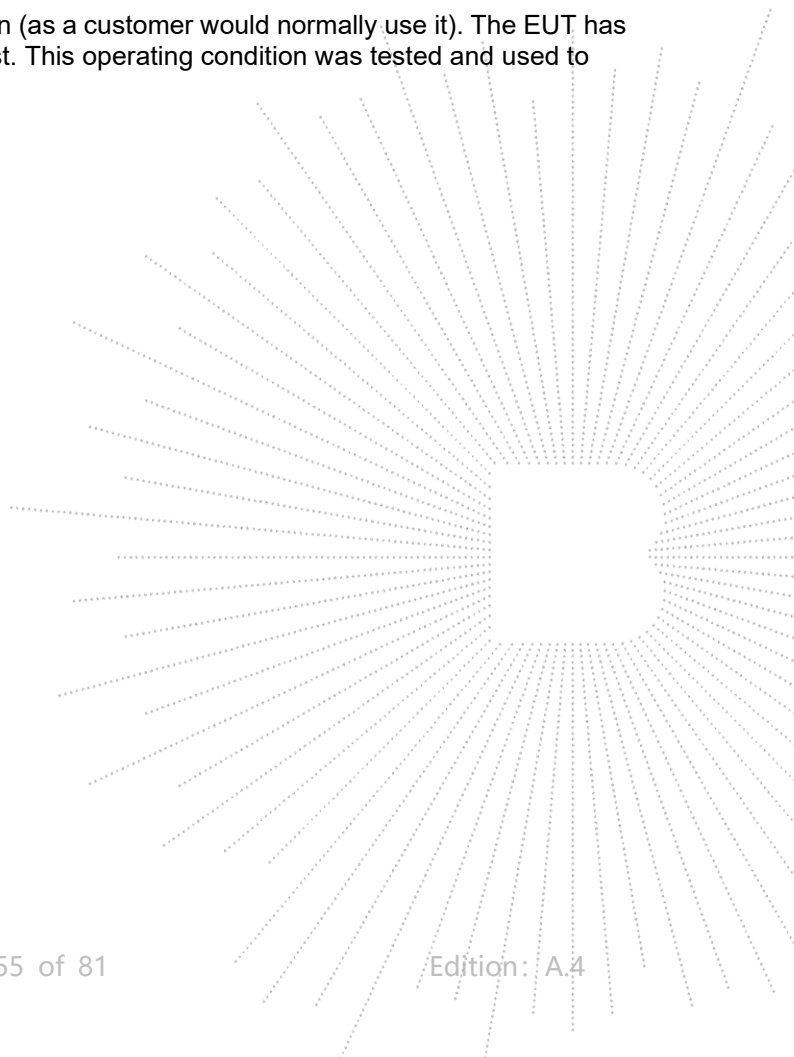

## 10.5 Test Result

Temperature :	26 °C	Relative Humidity :	54%
Pressure :	101kPa	Test Voltage :	DC 5V from adapter
Test Mode :	TX (5.1G) Mode Frequency U-NII-1 (5180-5240MHz)		

Mode	Test Channel	Frequency	Maximum output power. Antenna port (AV)	LIMIT	Result
		(MHz)	(dBm)	dBm	
TX 802.11a Mode	CH36	5180	10.97	24	Pass
	CH40	5200	10.88	24	Pass
	CH48	5240	10.87	24	Pass
TX 802.11 n20M Mode	CH36	5180	9.45	24	Pass
	CH40	5200	9.33	24	Pass
	CH48	5240	9.53	24	Pass
TX 802.11 n40M Mode	CH38	5190	8.62	24	Pass
	CH46	5230	8.5	24	Pass
TX 802.11 AC20M Mode	CH36	5180	8.75	24	Pass
	CH40	5200	8.63	24	Pass
	CH48	5240	9.94	24	Pass
TX 802.11 AC40M Mode	CH38	5190	8.57	24	Pass
	CH46	5230	8.47	24	Pass
TX 802.11 AC80M Mode	CH42	5210	7.39	24	Pass



## 11. Out Of Band Emissions

### 11.1 Block Diagram Of Test Setup

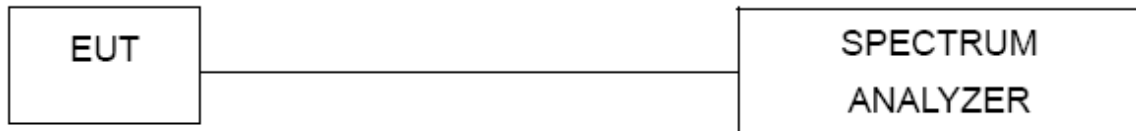

### 11.2 Limit

According to FCC §15.407(b)

Undesirable emission limits. Except as shown in paragraph (b)(7) of this section, the maximum emissions outside of the frequency bands of operation shall be attenuated in accordance with the following limits:

- (1) For transmitters operating in the 5.15-5.25 GHz band: All emissions outside of the 5.15-5.35 GHz band shall not exceed an e.i.r.p. of  $-27$  dBm/MHz.
- (2) All emissions shall be limited to a level of  $-27$  dBm/MHz at 75 MHz or more above or below the band edge increasing linearly to 10 dBm/MHz at 25 MHz above or below the band edge, and from 25 MHz above or below the band edge increasing linearly to a level of 15.6 dBm/MHz at 5 MHz above or below the band edge, and from 5 MHz above or below the band edge increasing linearly to a level of 27 dBm/MHz at the band edge.

### 11.3 Test Procedure

1. Check the calibration of the measuring instrument using either an internal calibrator or a known signal from an external generator.
2. Position the EUT without connection to measurement instrument. Turn on the EUT and connect its antenna terminal to measurement instrument via a low loss cable. Then set it to any one measured frequency within its operating range, and make sure the instrument is operated in its linear range.
3. Set RBW of spectrum analyzer to 1 MHz with a convenient frequency span.
4. Measure the highest amplitude appearing on spectral display and set it as a reference level. Plot the graph with marking the highest point and edge frequency.
5. Repeat above procedures until all measured frequencies were complete.

### 11.4 EUT Operating Conditions

The EUT was configured for testing in a typical fashion (as a customer would normally use it). The EUT has been programmed to continuously transmit during test. This operating condition was tested and used to collect the included data

## 11.5 Test Result

Temperature :	26 °C	Relative Humidity :	54%
Pressure :	101kPa	Test Voltage :	DC 5V from adapter
Test Mode :	TX (5.1G) Mode Frequency U-NII-1 (5180-5240MHz)		

Condition	Mode	Frequency (MHz)	Max Value (dBc)	Limit (dBc)	Verdict
NVNT	a	5180	-38.79	-27	Pass
NVNT	a	5240	-44.22	-27	Pass
NVNT	n20	5180	-39.46	-27	Pass
NVNT	n20	5240	-44.6	-27	Pass
NVNT	n40	5190	-35.45	-27	Pass
NVNT	n40	5230	-45.31	-27	Pass
NVNT	ac20	5180	-42.86	-27	Pass
NVNT	ac20	5240	-45.71	-27	Pass
NVNT	ac40	5190	-33.96	-27	Pass
NVNT	ac40	5230	-45.5	-27	Pass
NVNT	ac80	5210	-43.13	-27	Pass
NVNT	ac80	5210	-32.28	-27	Pass

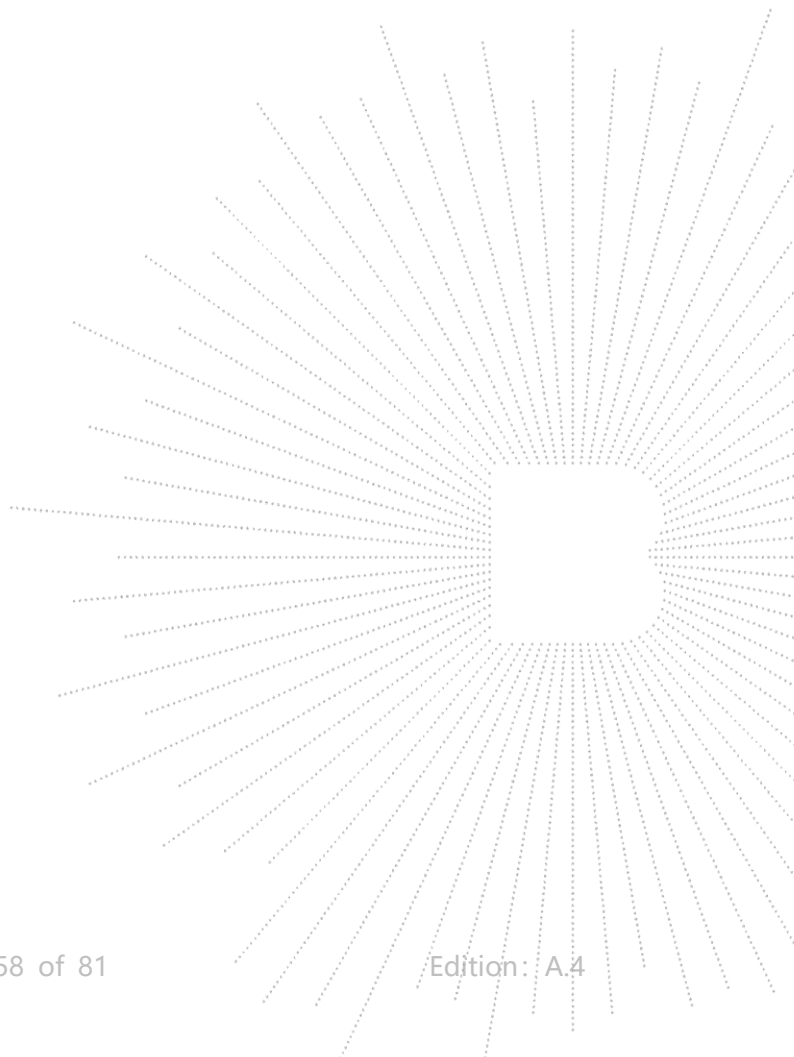

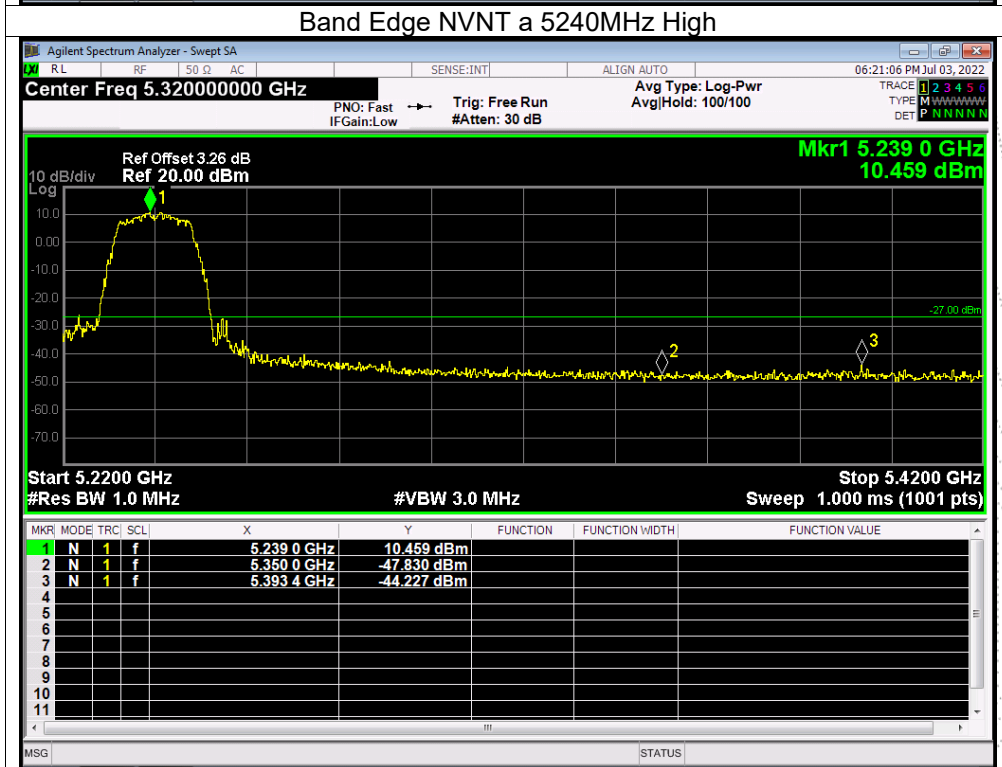
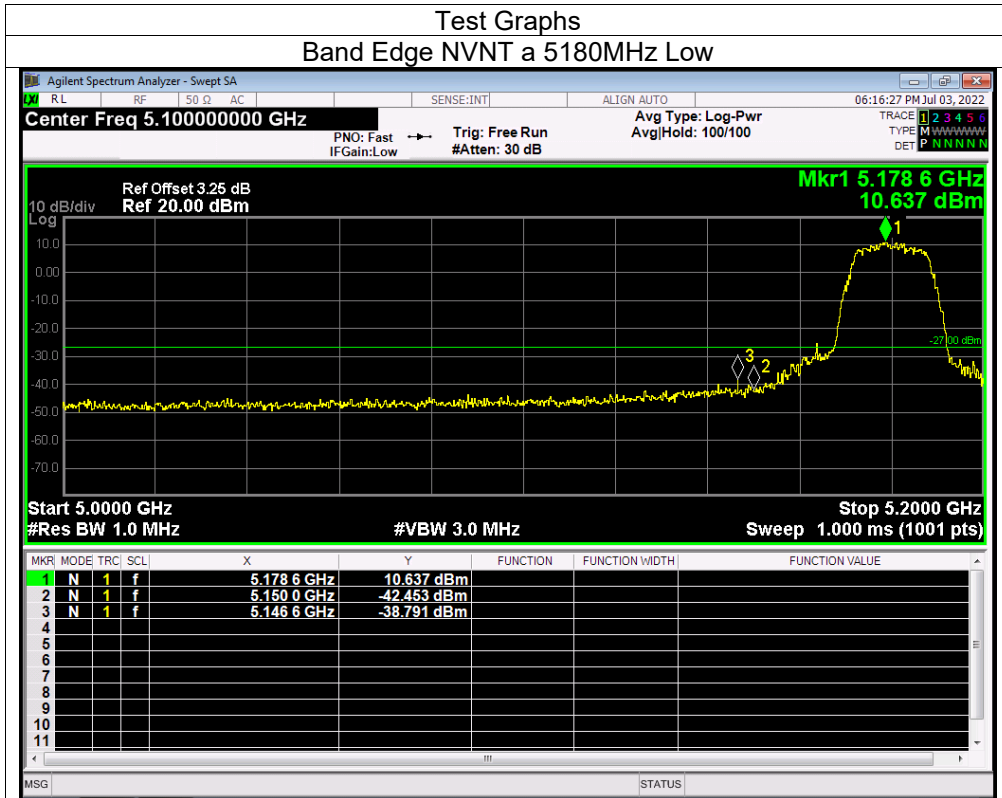

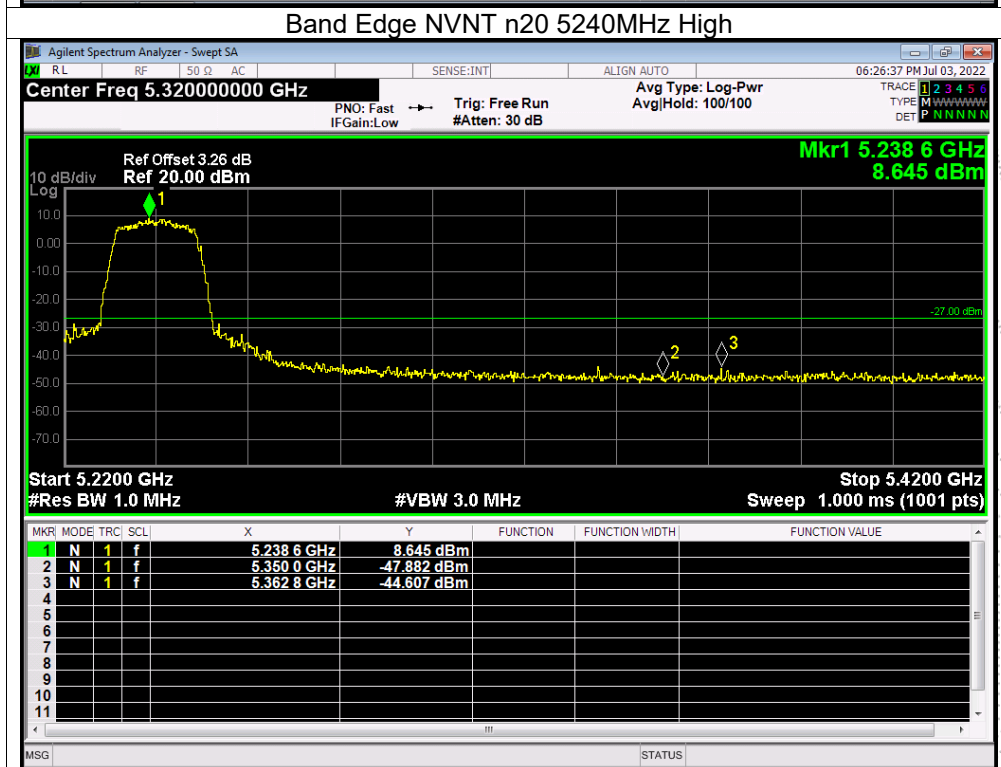
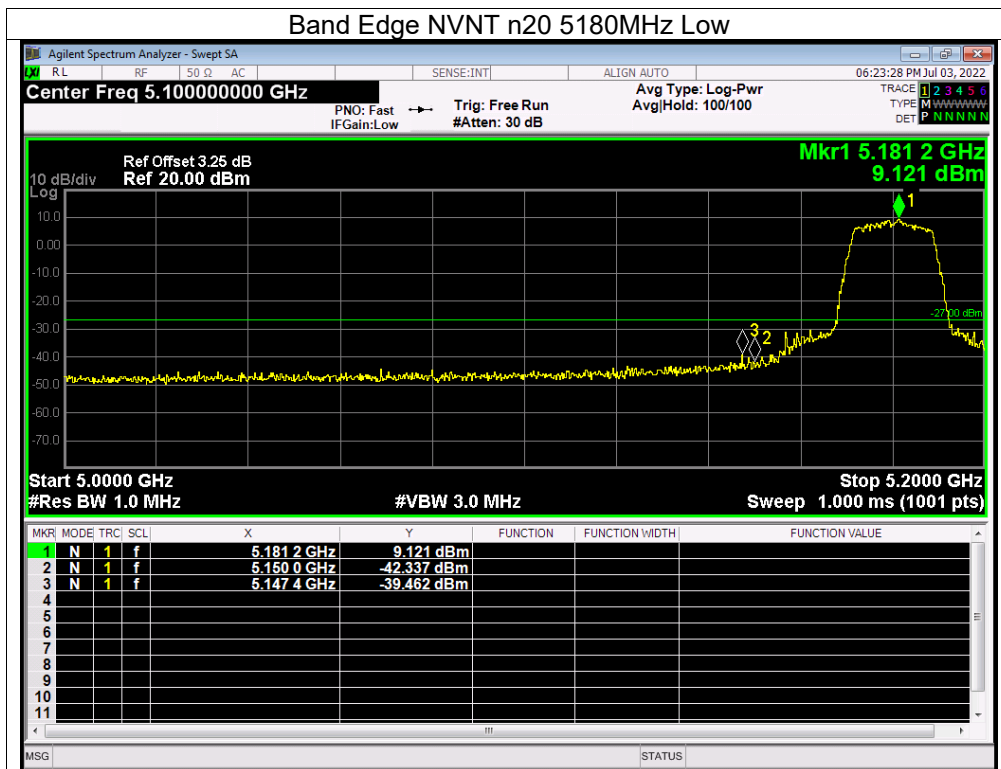

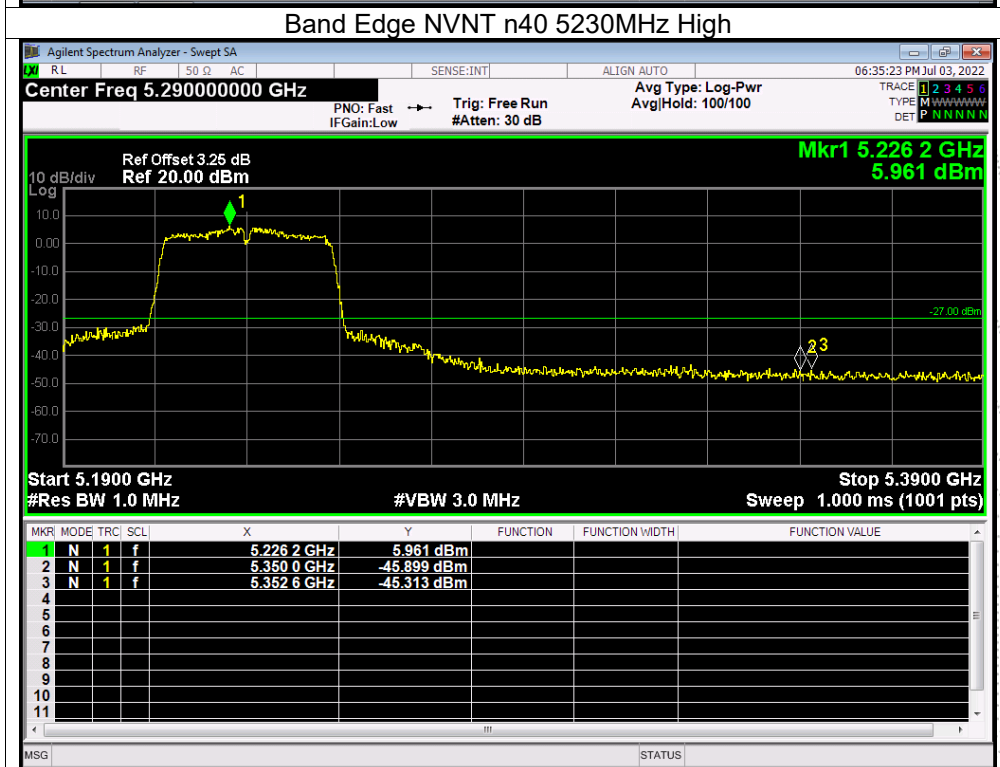
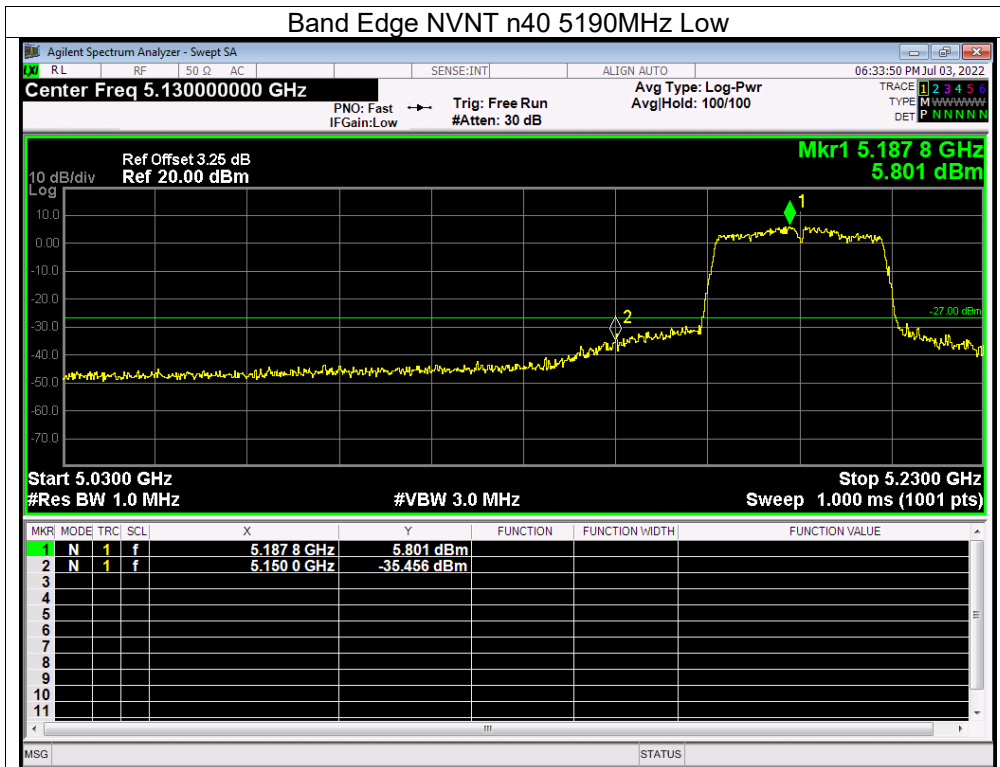

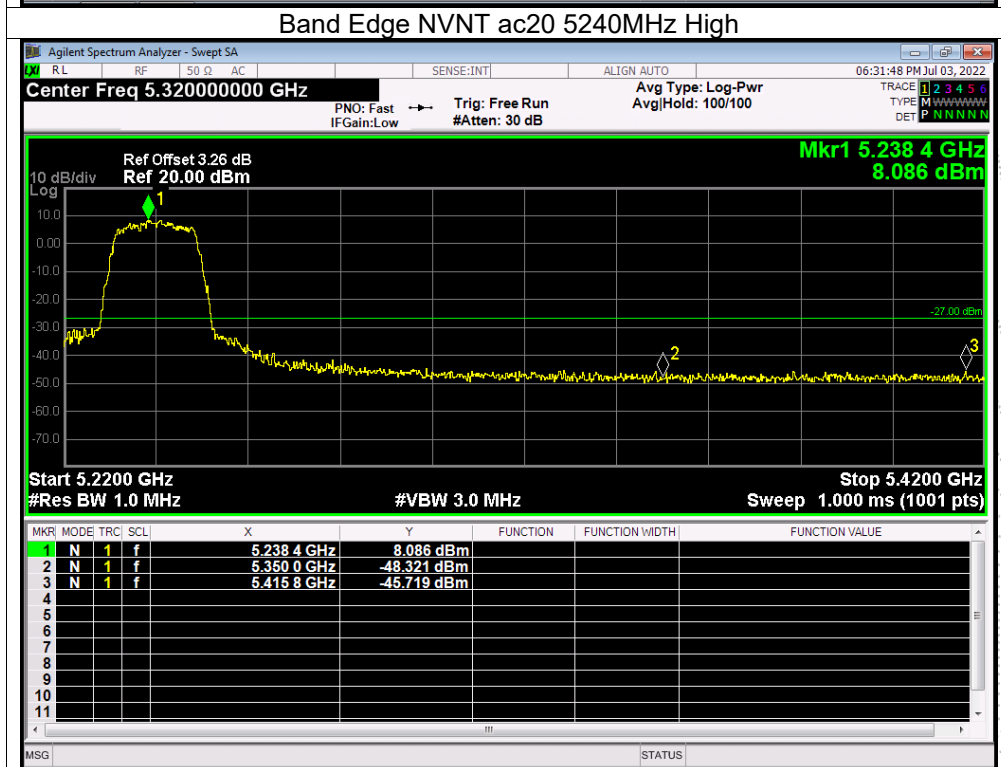
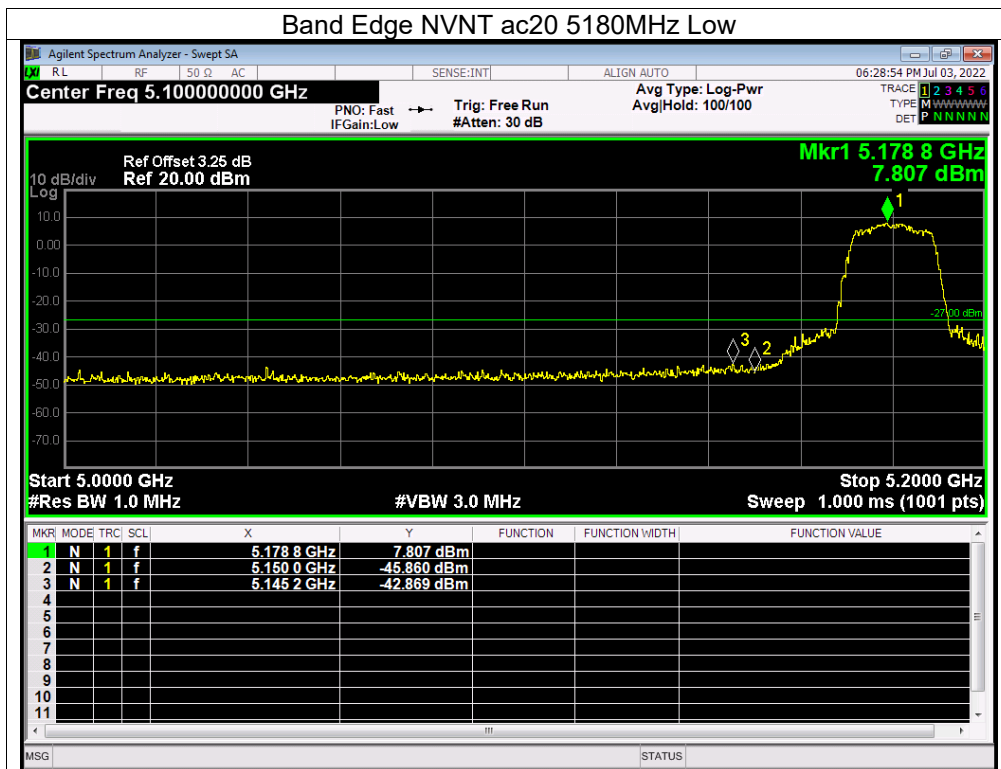

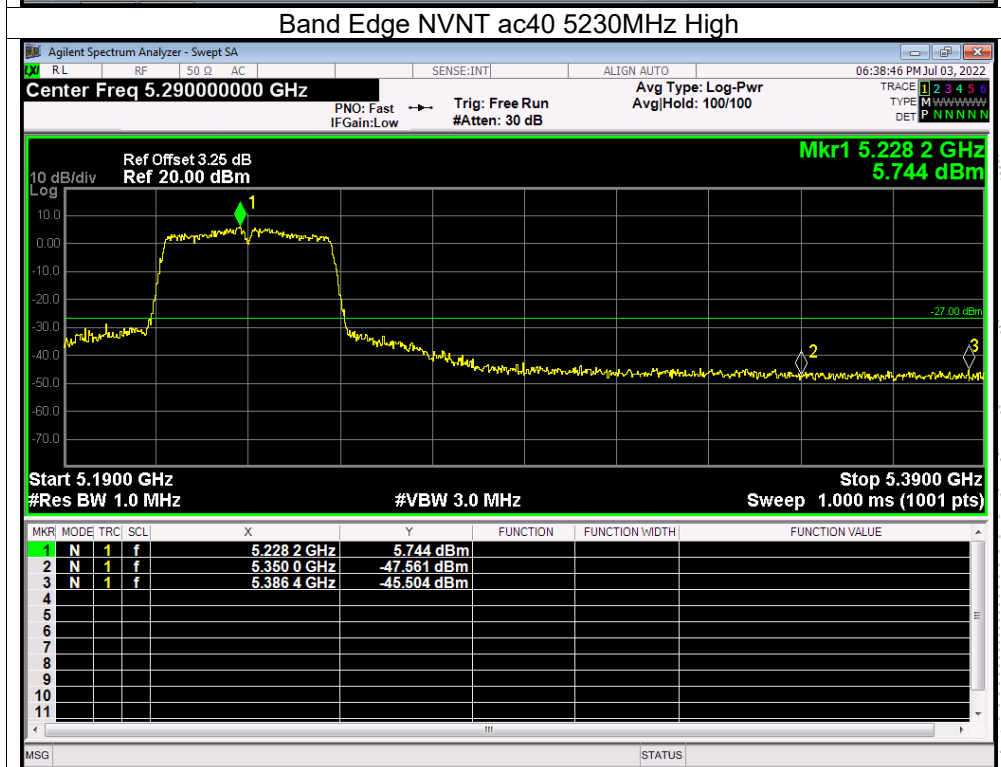
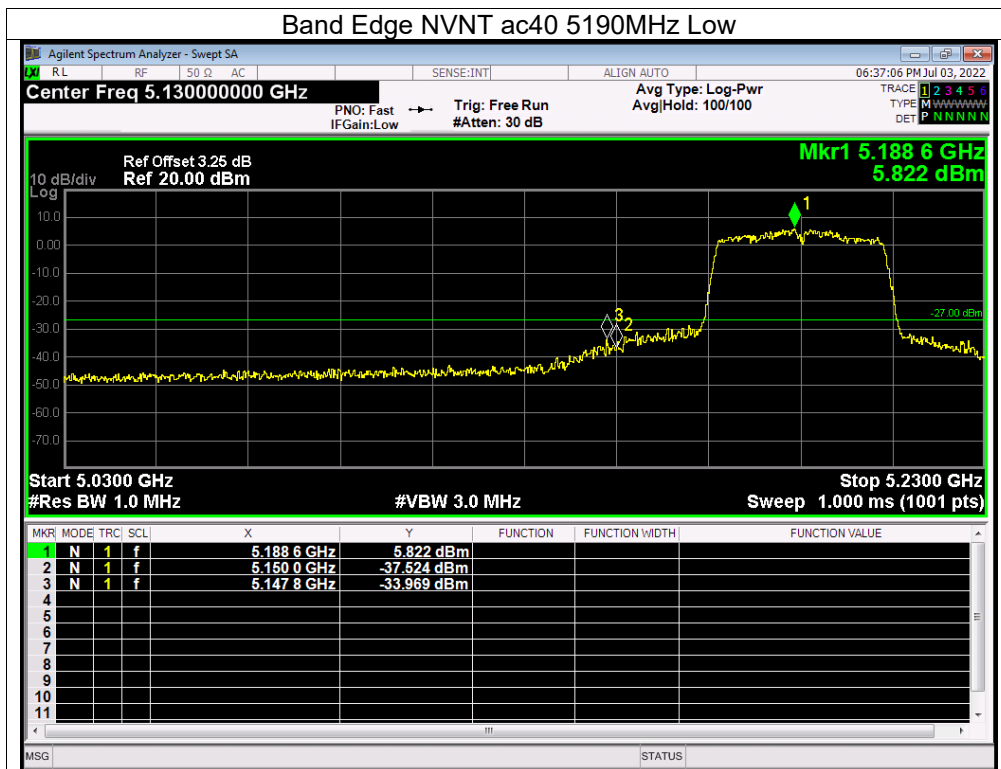

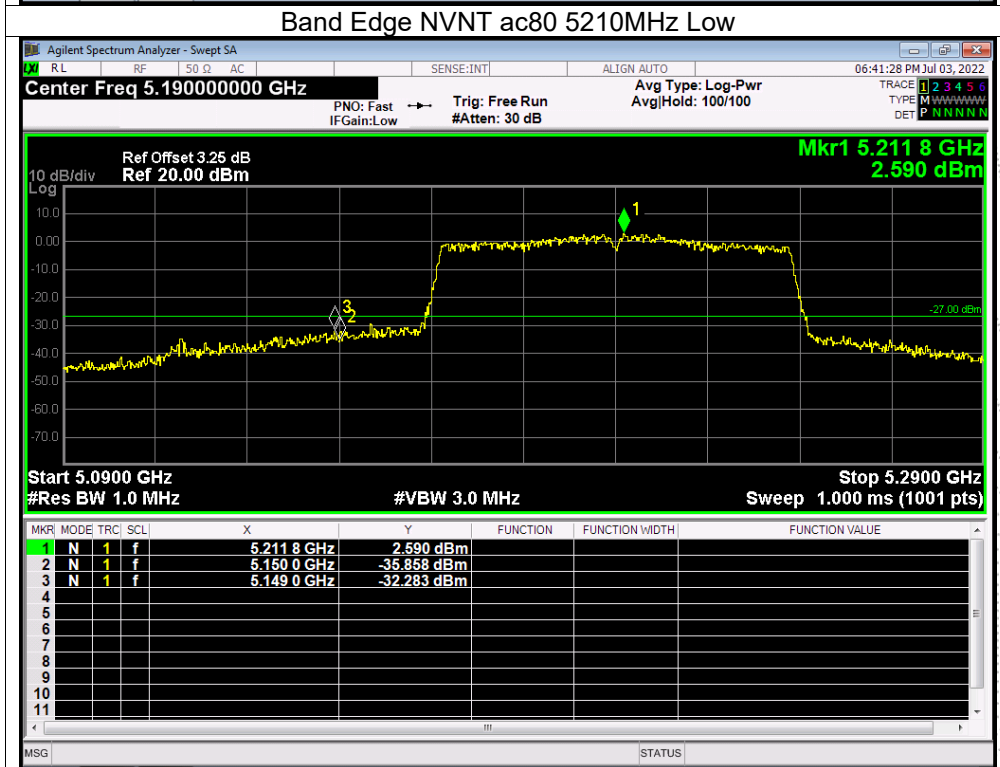
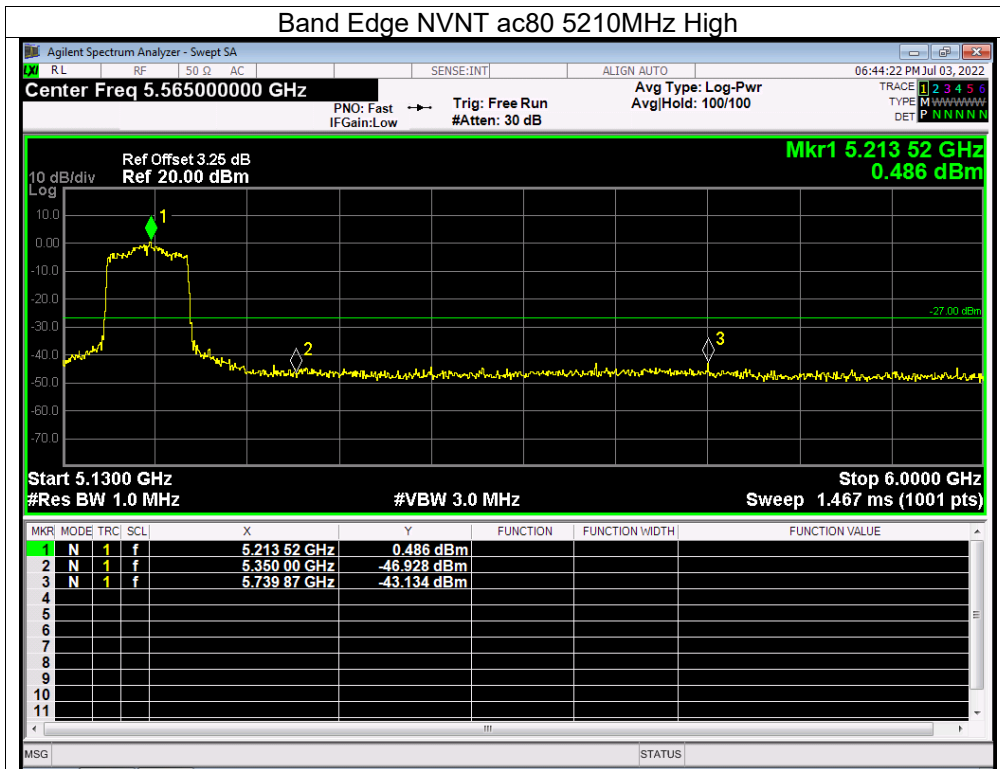



## 12. Spurious RF Conducted Emissions

### 12.1 Block Diagram Of Test Setup

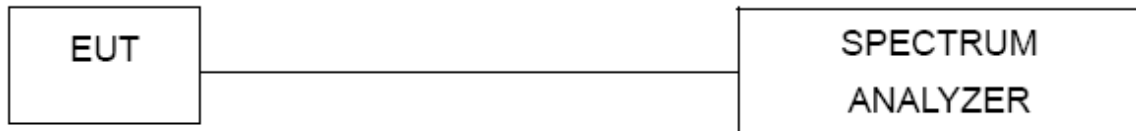

### 12.2 Limit

Undesirable emission limits. Except as shown in paragraph (b)(7) of this section, the maximum emissions outside of the frequency bands of operation shall be attenuated in accordance with the following limits:

(1) For transmitters operating in the 5.15-5.25 GHz band: All emissions outside of the 5.15-5.35 GHz band shall not exceed an e.i.r.p. of  $-27$  dBm/MHz.

(2) For transmitters operating in the 5.725-5.85 GHz band (i) All emissions shall be limited to a level of  $-27$  dBm/MHz at 75 MHz or more above or below the band edge increasing linearly to 10 dBm/MHz at 25 MHz above or below the band edge, and from 25 MHz above or below the band edge increasing linearly to a level of 15.6 dBm/MHz at 5 MHz above or below the band edge, and from 5 MHz above or below the band edge increasing linearly to a level of 27 dBm/MHz at the band edge..

### 12.3 Test Procedure

1. Check the calibration of the measuring instrument using either an internal calibrator or a known signal from an external generator.
2. Position the EUT without connection to measurement instrument. Turn on the EUT and connect its antenna terminal to measurement instrument via a low loss cable. Then set it to any one measured frequency within its operating range, and make sure the instrument is operated in its linear range.
3. Set RBW of spectrum analyzer to 1 MHz with a convenient frequency span.
4. Measure the highest amplitude appearing on spectral display and set it as a reference level. Plot the graph with marking the highest point and edge frequency.
5. Repeat above procedures until all measured frequencies were complete.

### 12.4 Test Result

Remark: The measurement frequency range is from 9KHz to the 10th harmonic of the fundamental frequency. The lowest, middle and highest channels are tested to verify the spurious emissions and band edge measurement data.

About: 26.5GHz-40GHz, The amplitude of spurious emissions which are attenuated by more than 20dB below the permissible value has no need to be reported.

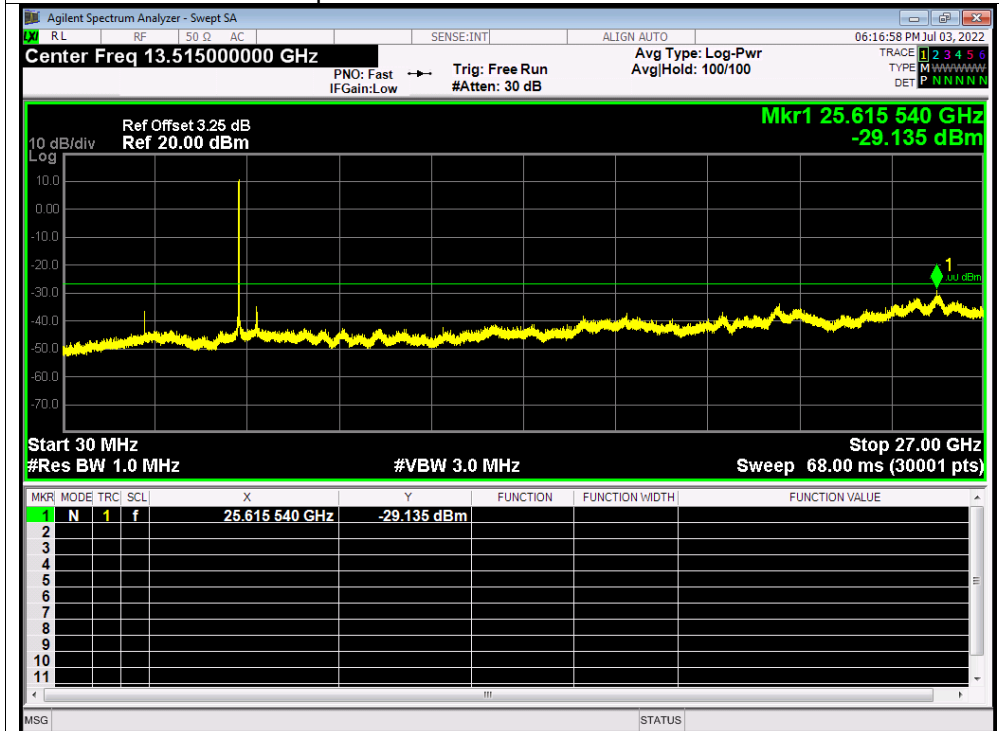
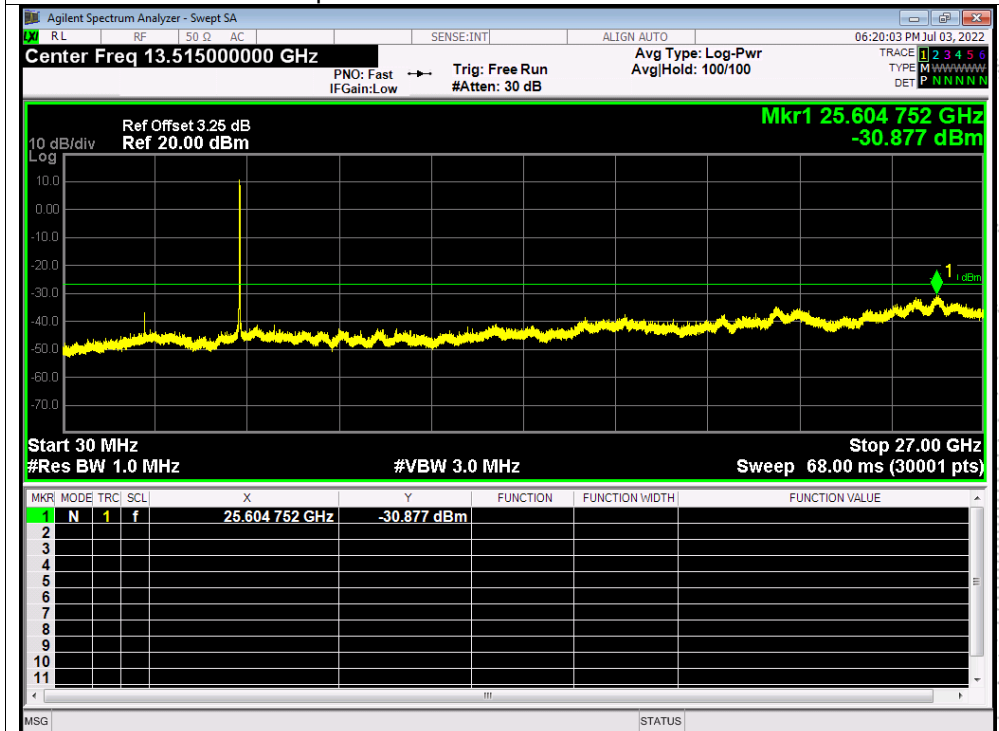
**5.1G**
**Test Graphs**
**Tx. Spurious NVNT a 5180MHz Emission**

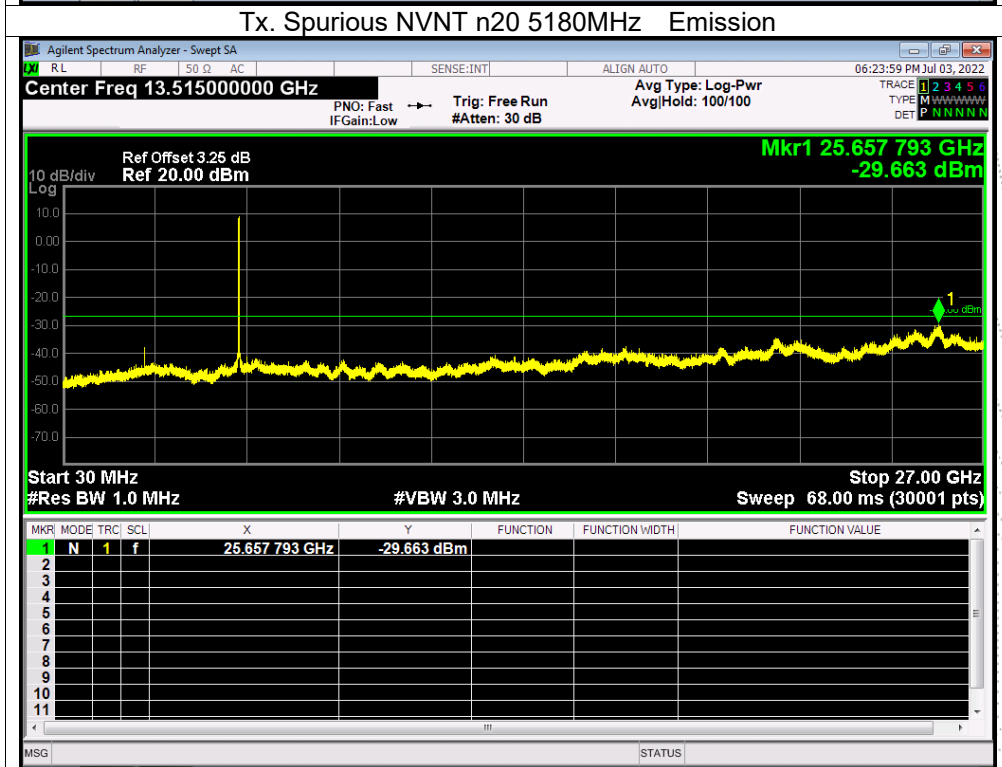
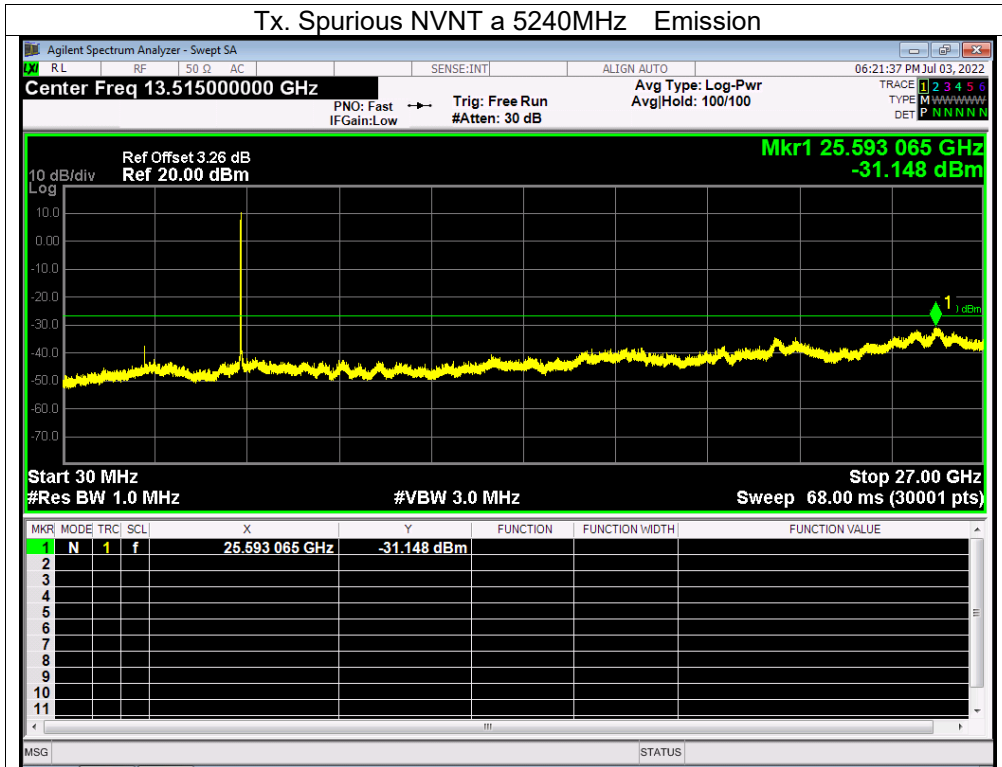
**Tx. Spurious NVNT a 5200MHz Emission**

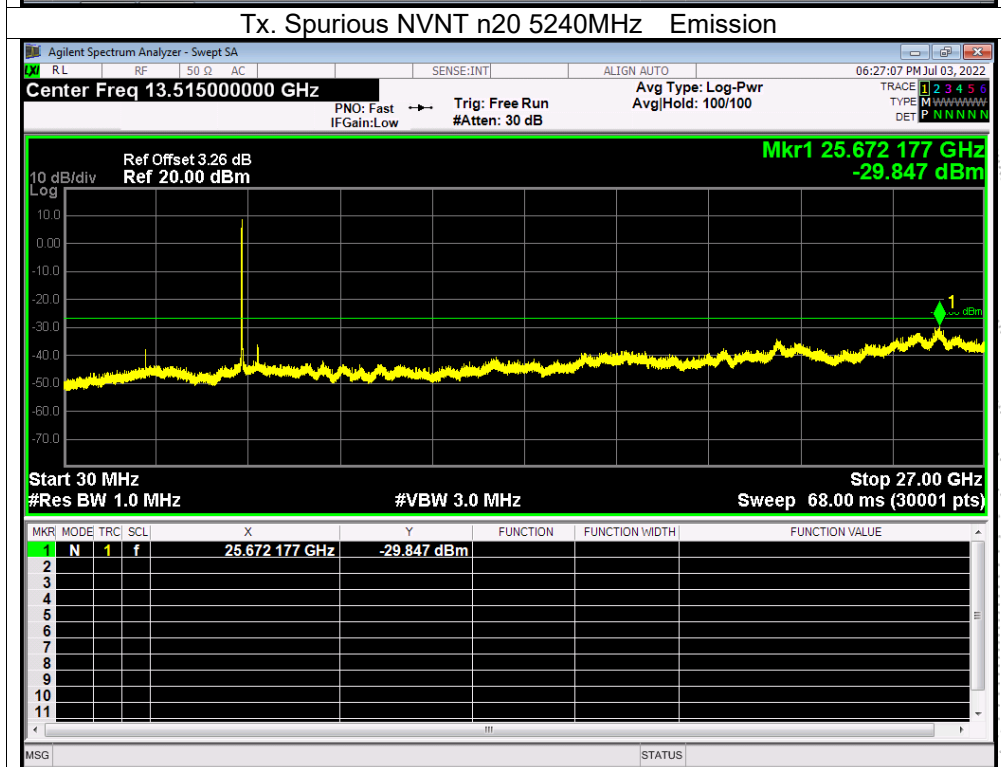
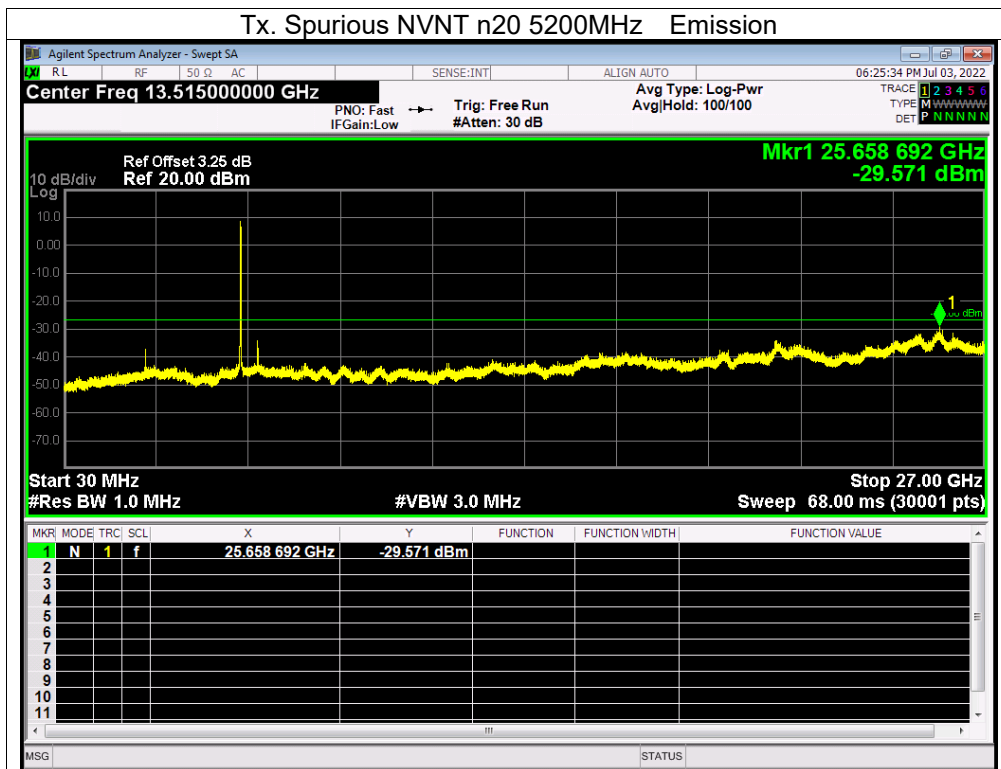

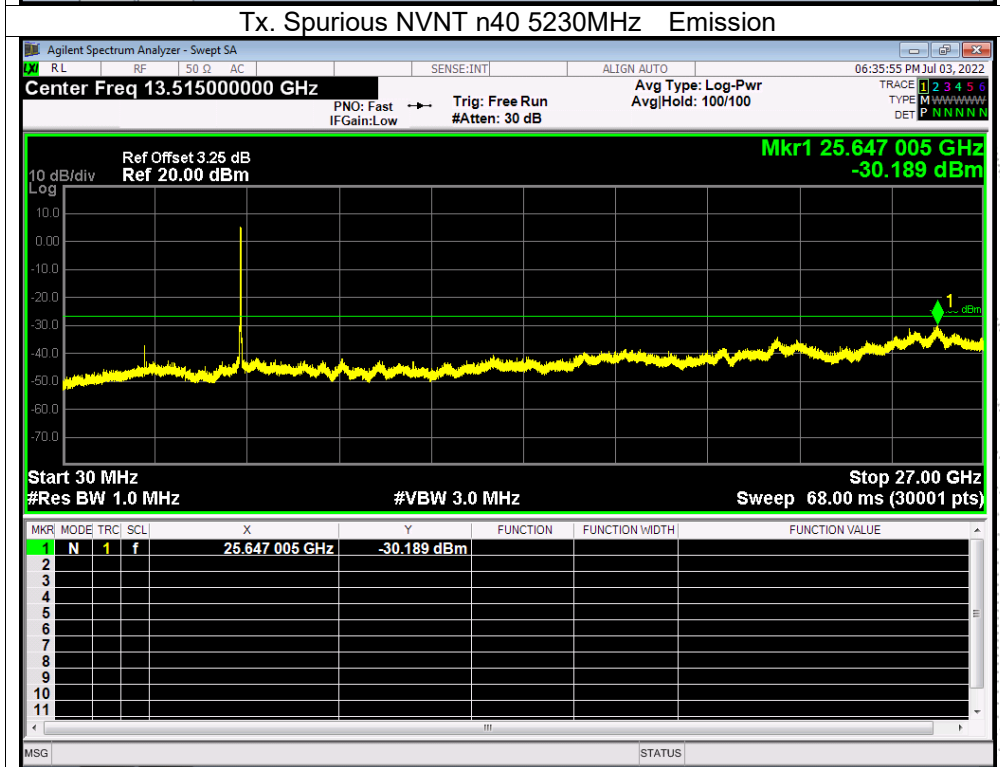
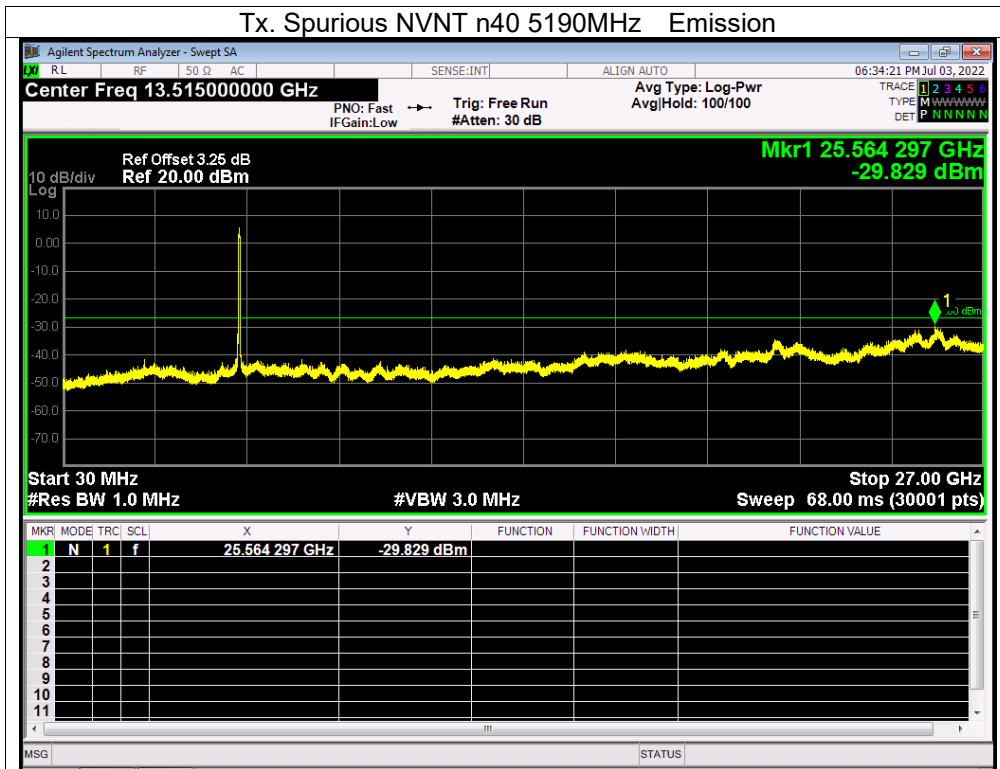

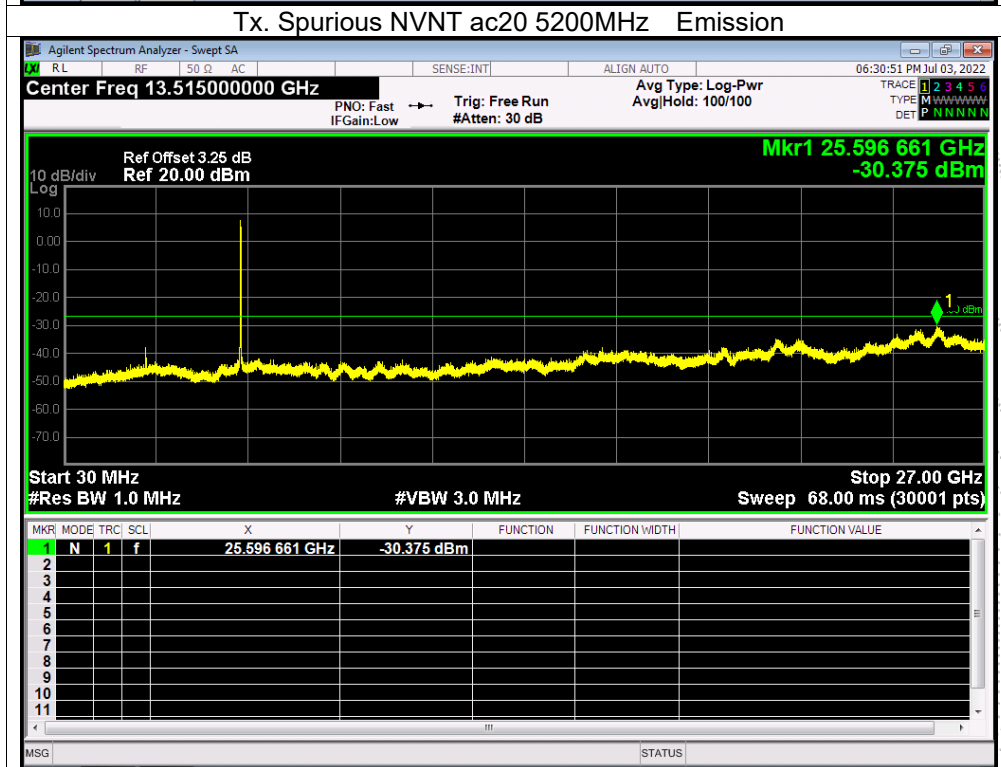
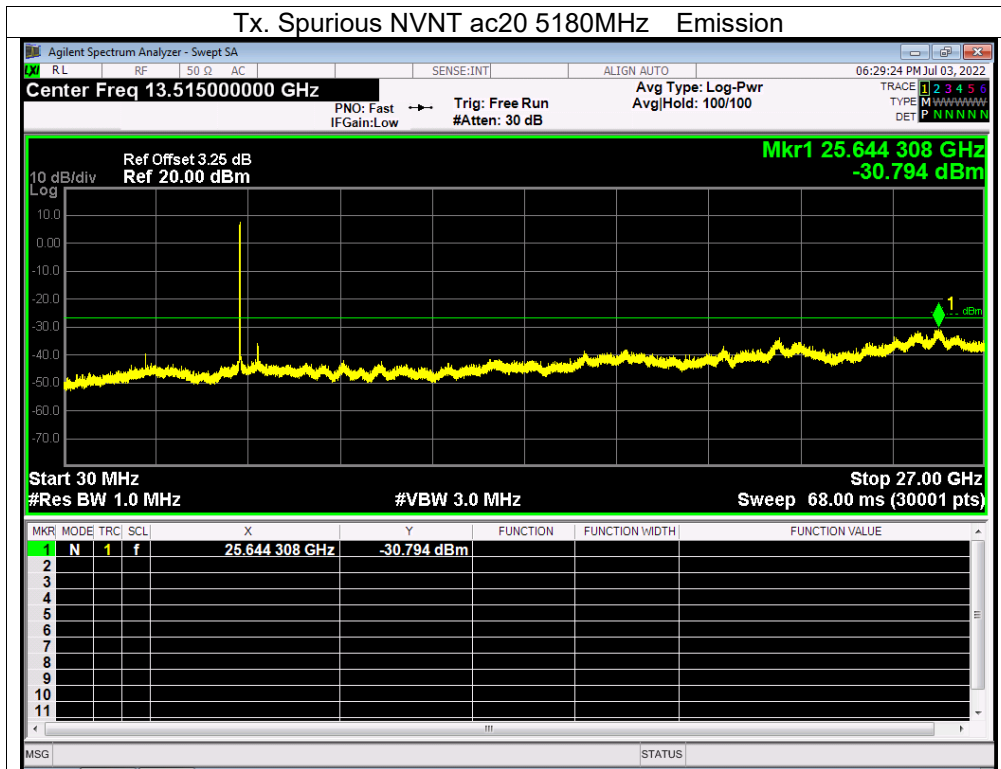

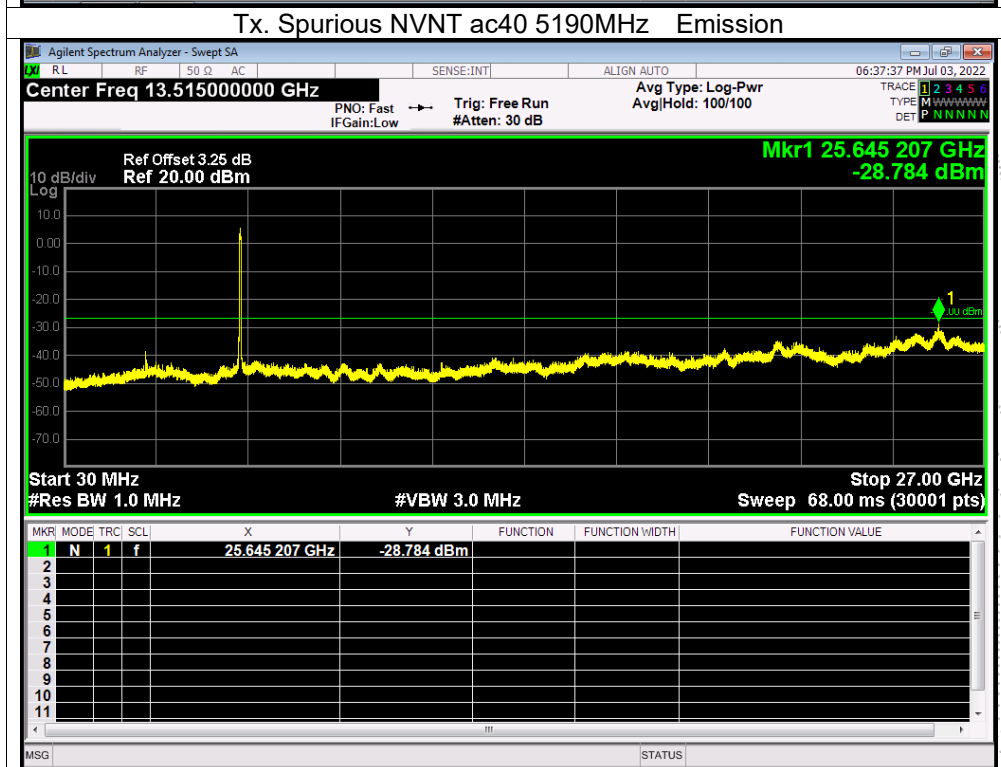
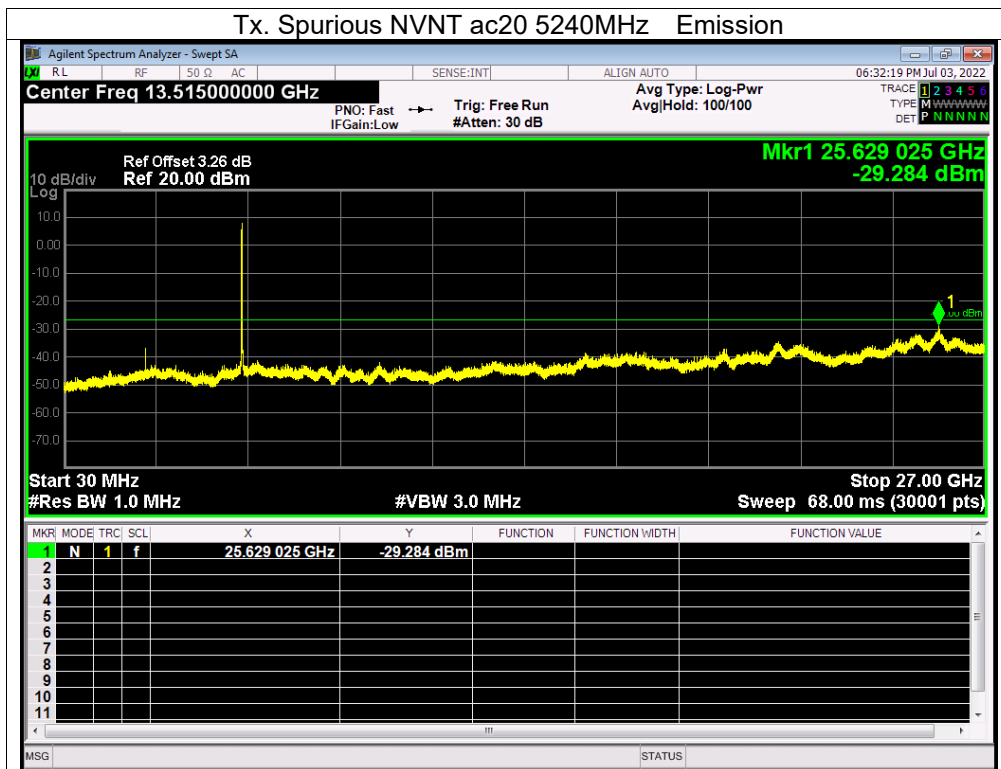



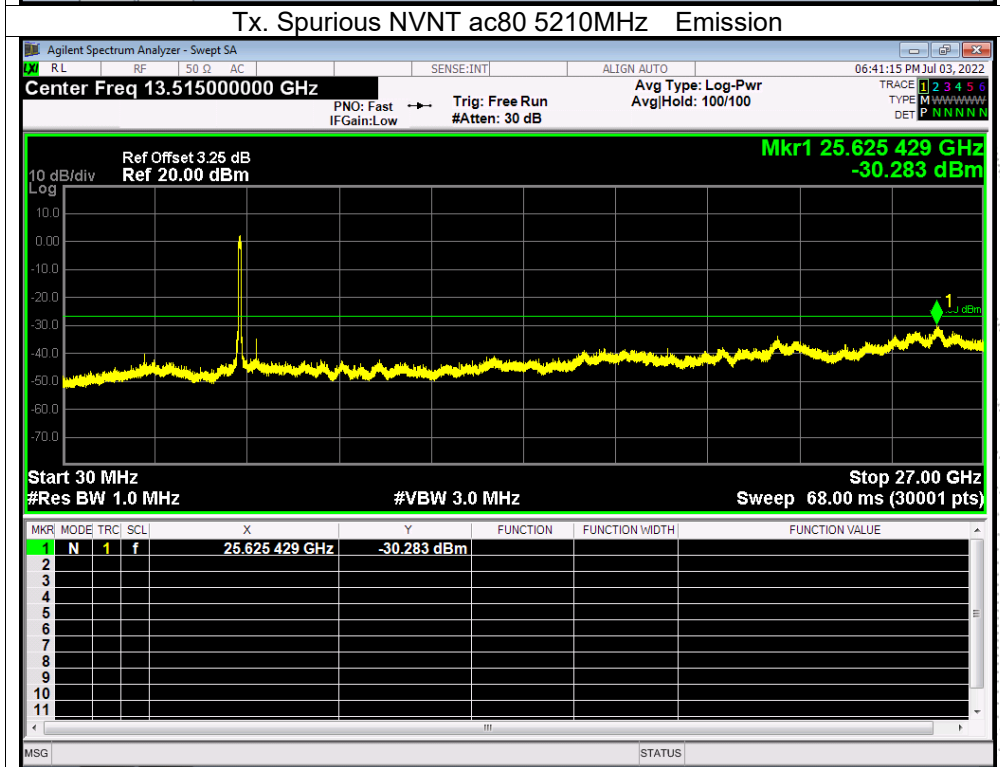
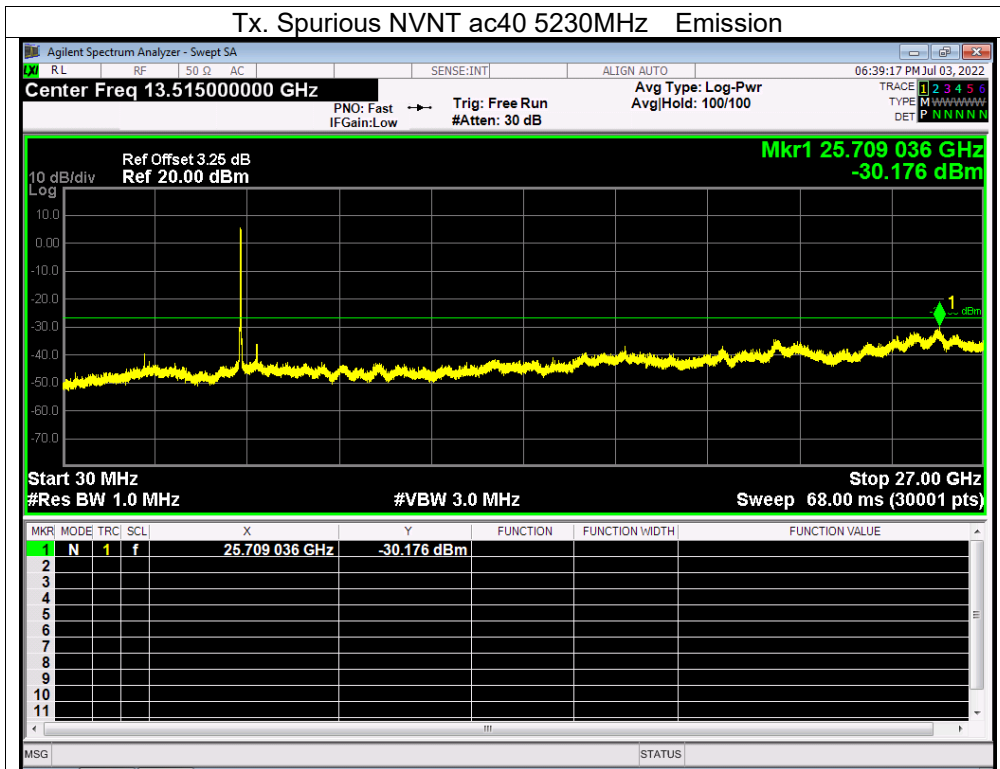



## 13. Frequency Stability Measurement

### 13.1 Block Diagram Of Test Setup



### 13.2 Limit

Manufactures of U-NII devices are responsible for ensuring frequency stability such that an emission is maintained within the band of operation under all conditions of normal operation as specified in the user's manual.

The transmitter center frequency tolerance shall be  $\pm 20$  ppm maximum for the 5 GHz band (IEEE 802.11n specification)..

### 13.3 Test Procedure

1. The transmitter output (antenna port) was connected to the spectrum analyzer.
2. EUT have transmitted absence of modulation signal and fixed channelize.
3. Set the spectrum analyzer span to view the entire absence of modulation emissions bandwidth.
4. Set RBW = 10 kHz, VBW = 10 kHz with peak detector and maxhold settings.
5.  $f_c$  is declaring of channel frequency. Then the frequency error formula is  $(f_c - f) / f_c \times 10^6$  ppm and he limit is less than  $\pm 20$  ppm (IEEE 802.11n specification).
6. The test extreme voltage is to change the primary supply voltage from 85 to 115 percent of the nominal value
7. Extreme temperature is  $-20^\circ\text{C} \sim 70^\circ\text{C}$ .

## 13.4 Test Result

Temperature :	26 °C	Relative Humidity :	54%
Pressure :	101kPa	Test Voltage :	DC 5V from adapter
Test Mode :	TX Frequency U-NII-1 (5180-5240MHz)		

## Voltage vs. Frequency Stability

TEST CONDITIONS				Reference Frequency : 5180MHz			
				f	fc	Max. Deviation (MHz)	Max. Deviation (ppm)
T nom (°C)	20	V nom (V)	5.00	5180.0026	5180	0.0026	0.4936
		V max (V)	5.75	5180.0096	5180	0.0096	1.8475
		V min (V)	4.25	5180.0074	5180	0.0074	1.4344
Limits				5150-5250 MHz			
Result				Complies			

## Temperature vs. Frequency Stability

TEST CONDITIONS				Reference Frequency: 5180MHz			
				f	fc	Max. Deviation (MHz)	Max. Deviation (ppm)
V nom (V)	DC 5V	T (°C)	-20	5180.0134	5180	0.0134	2.5810
		T (°C)	-10	5180.0126	5180	0.0126	2.4380
		T (°C)	0	5180.0046	5180	0.0046	0.8894
		T (°C)	10	5180.0041	5180	0.0041	0.7931
		T (°C)	20	5180.0080	5180	0.0080	1.5487
		T (°C)	30	5180.0128	5180	0.0128	2.4689
		T (°C)	40	5180.0007	5180	0.0007	0.1432
		T (°C)	50	5180.0109	5180	0.0109	2.1085
		T (°C)	60	5180.0082	5180	0.0082	1.5882
		T (°C)	70	5180.0101	5180	0.0101	1.9564
Limits				5150-5250 MHz			
Result				Complies			

## Voltage vs. Frequency Stability

TEST CONDITIONS				Reference Frequency: 5200MHz			
				f	fc	Max. Deviation (MHz)	Max. Deviation (ppm)
T <sub>nom</sub> (°C)	20	V nom (V)	5.00	5200.0107	5200	0.0107	2.0556
		V max (V)	5.75	5200.0034	5200	0.0034	0.6567
		V min (V)	4.25	5200.0020	5200	0.0020	0.3893
Limits				5725-5850 MHz			
Result				Complies			

## Temperature vs. Frequency Stability

TEST CONDITIONS				Reference Frequency: 5200MHz			
				f	fc	Max. Deviation (MHz)	Max. Deviation (ppm)
V <sub>nom</sub> (V)	DC 5V	T (°C)	-20	5200.00918	5200	0.00918	1.7654
		T (°C)	-10	5200.00925	5200	0.00925	1.7783
		T (°C)	0	5200.00911	5200	0.00911	1.7527
		T (°C)	10	5200.00140	5200	0.00140	0.2692
		T (°C)	20	5200.00479	5200	0.00479	0.9215
		T (°C)	30	5200.00154	5200	0.00154	0.2963
		T (°C)	40	5200.00015	5200	0.00015	0.0296
		T (°C)	50	5200.01203	5200	0.01203	2.3131
		T (°C)	60	5200.00610	5200	0.00610	1.1726
		T (°C)	70	5200.00034	5200	0.00034	0.0654
Limits				5150-5250 MHz			
Result				Complies			

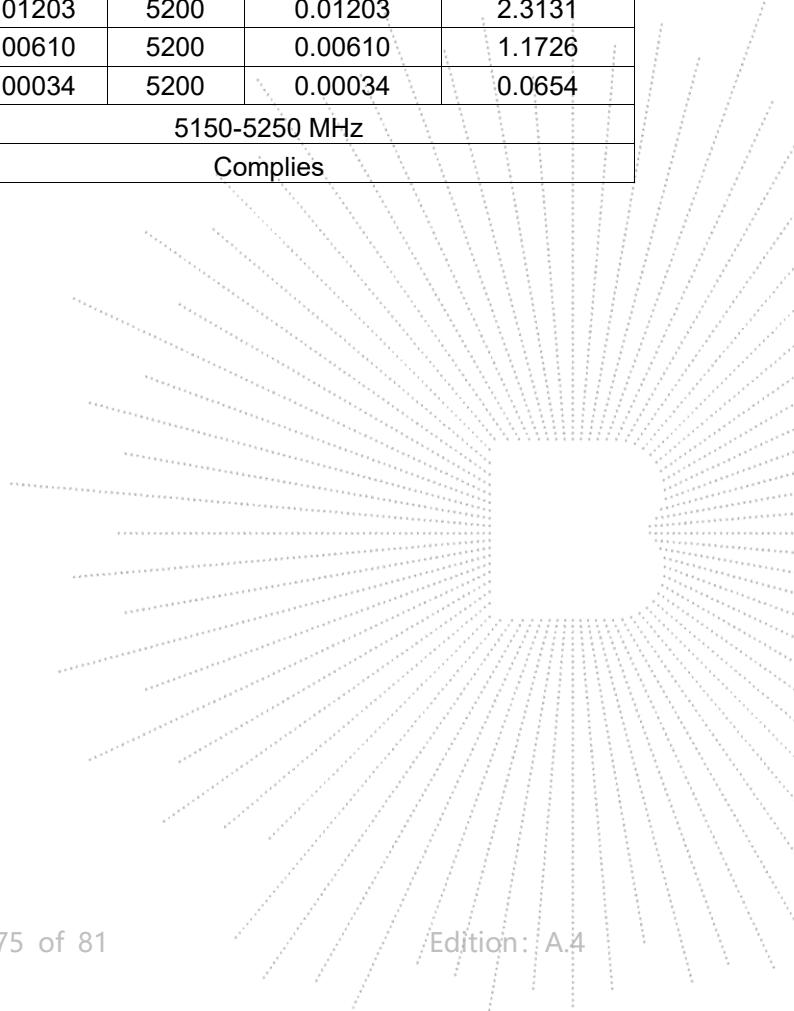

## Voltage vs. Frequency Stability

TEST CONDITIONS				Reference Frequency: 5240MHz			
				f	fc	Max. Deviation (MHz)	Max. Deviation (ppm)
T <sub>nom</sub> (°C)	20	V nom (V)	5.00	5240.0051	5240	0.0051	0.9752
		V max (V)	5.75	5240.0113	5240	0.0113	2.1474
		V min (V)	4.25	5240.0126	5240	0.0126	2.4076
Limits				5150-5250 MHz			
Result				Complies			

## Temperature vs. Frequency Stability

TEST CONDITIONS				Reference Frequency: 5240MHz			
				f	fc	Max. Deviation (MHz)	Max. Deviation (ppm)
V <sub>nom</sub> (V)	DC 5V	T (°C)	-20	5240.0111	5240	0.0111	2.1112
		T (°C)	-10	5240.0102	5240	0.0102	1.9514
		T (°C)	0	5240.0047	5240	0.0047	0.8922
		T (°C)	10	5240.0030	5240	0.0030	0.5644
		T (°C)	20	5240.0063	5240	0.0063	1.2027
		T (°C)	30	5240.0110	5240	0.0110	2.1039
		T (°C)	40	5240.0046	5240	0.0046	0.8720
		T (°C)	50	5240.0077	5240	0.0077	1.4687
		T (°C)	60	5240.0019	5240	0.0019	0.3718
		T (°C)	70	5240.0043	5240	0.0043	0.8203
Limits				5150-5250 MHz			
Result				Complies			

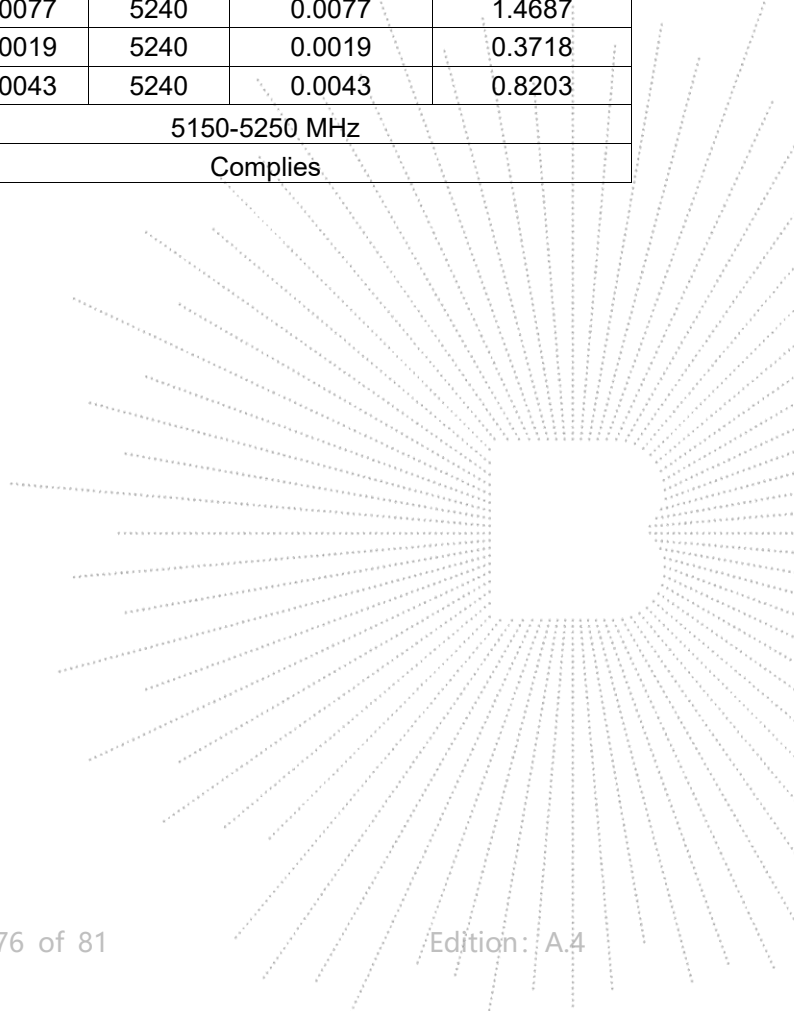

## 14. Antenna Requirement

### 14.1 Limit

15.203 requirement: For intentional device, according to 15.203: an intentional radiator shall be designed to ensure that no antenna other than that furnished by the responsible party shall be used with the device.

### 14.2 Test Result

The EUT antenna is Chip Antenna (antenna gain:2 dBi). It comply with the standard requirement.

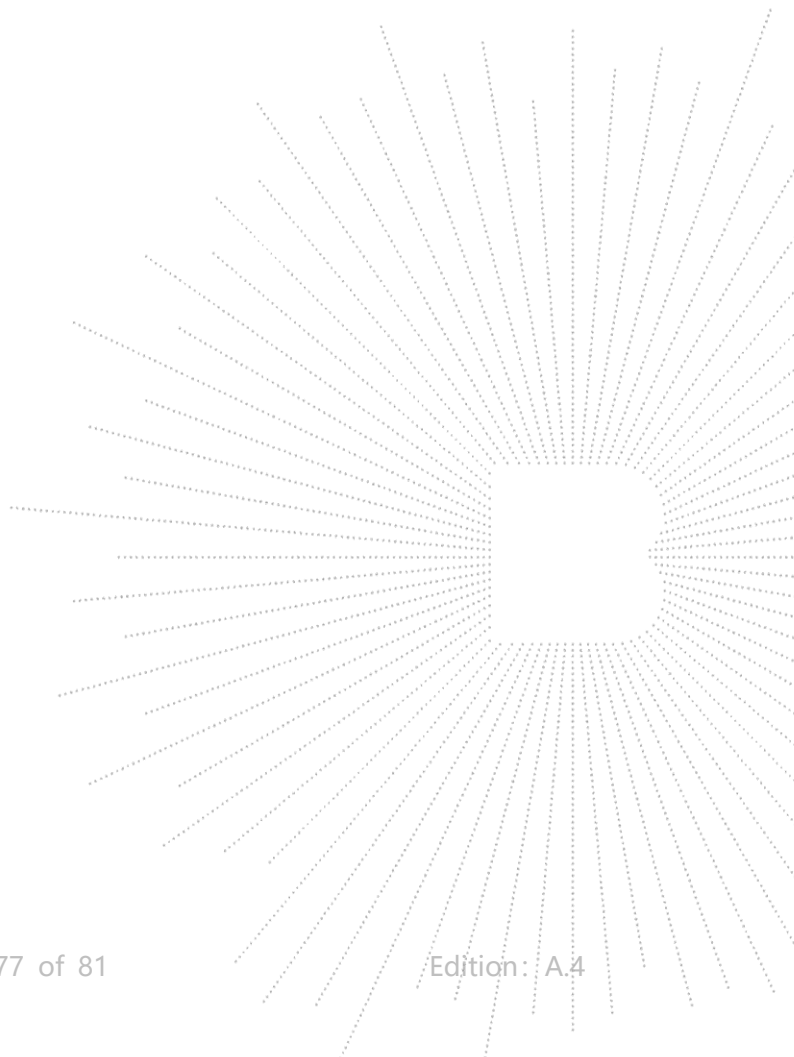

### 15. EUT Photographs

EUT Photo 1

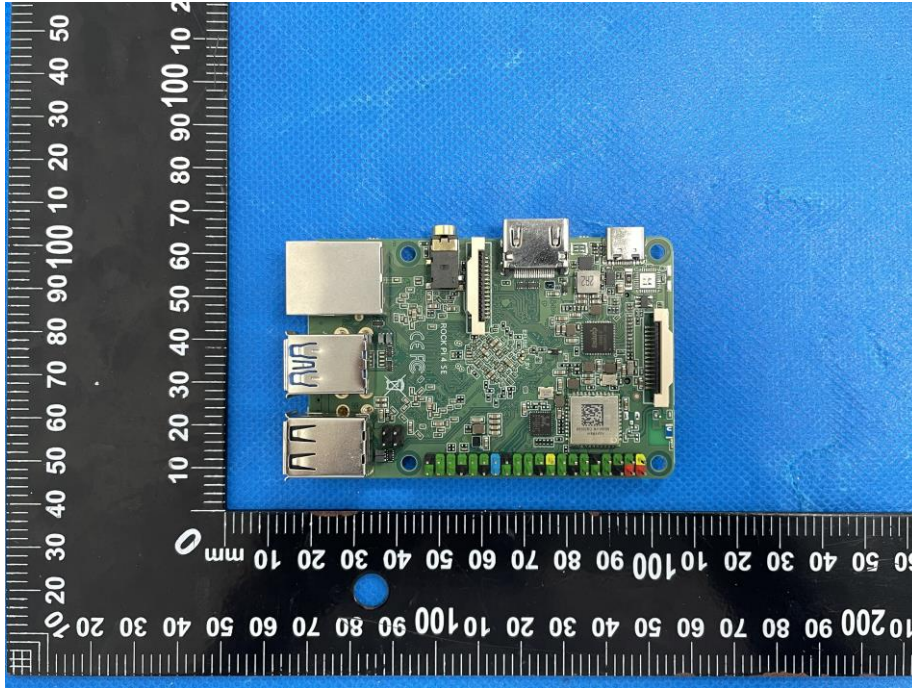

EUT Photo 2

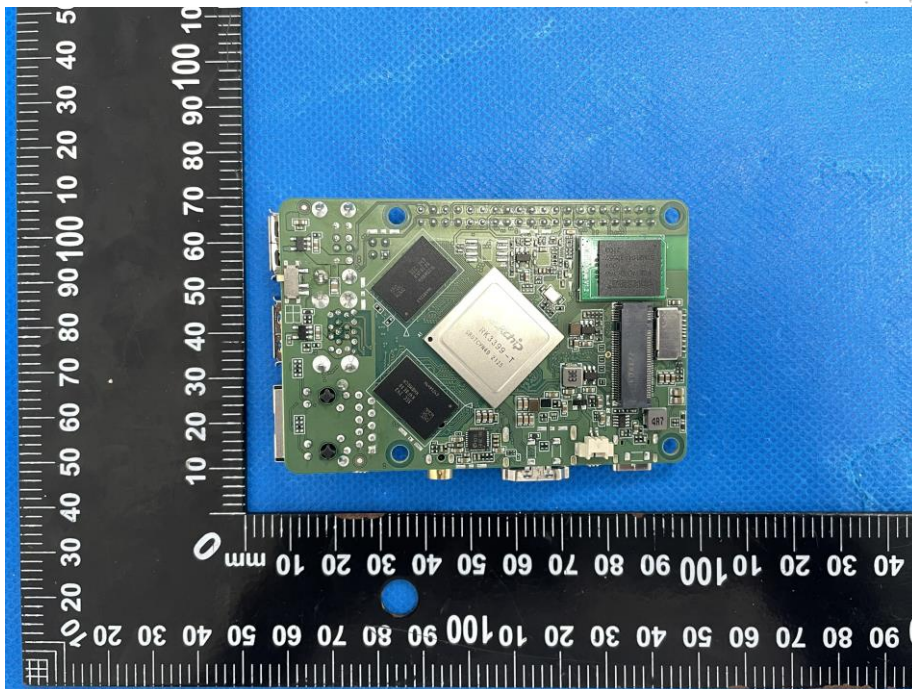

### 16. EUT Test Setup Photographs

#### Conducted Measurement Photo



#### Radiated Measurement Photos

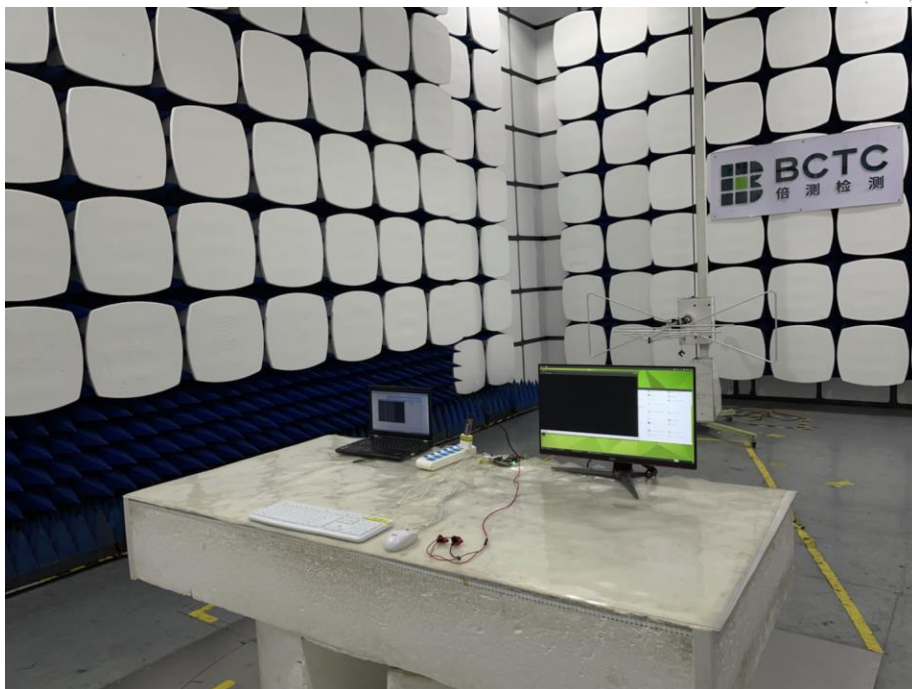

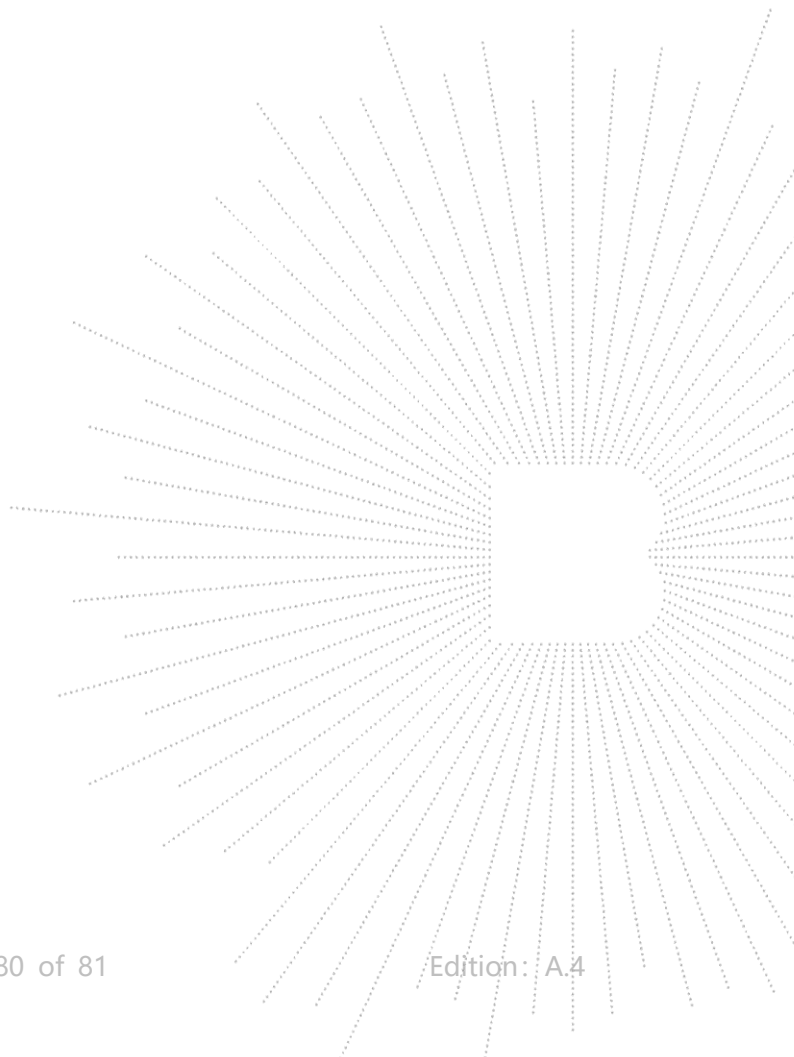
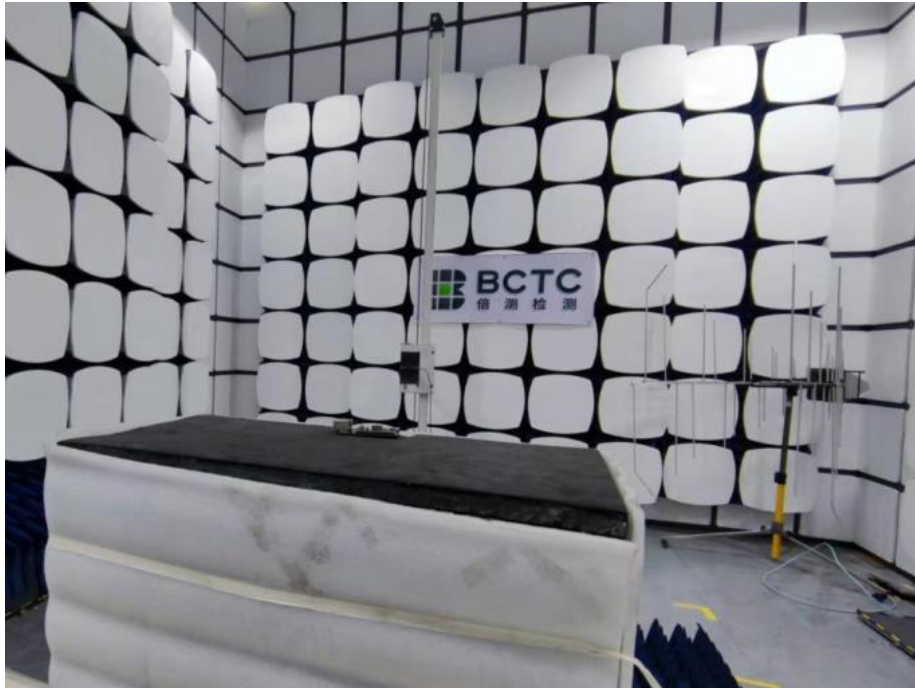



## STATEMENT

- 1.The equipment lists are traceable to the national reference standards.
- 2.The test report can not be partially copied unless prior written approval is issued from our lab.
- 3.The test report is invalid without stamp of laboratory.
- 4.The test report is invalid without signature of person(s) testing and authorizing.
- 5.The test process and test result is only related to the Unit Under Test.
- 6.The quality system of our laboratory is in accordance with ISO/IEC17025.
- 7.If there is any objection to report, the client should inform issuing laboratory within 15 days from the date of receiving test report.

Address:

1-2/F., Building B, Pengzhou Industrial Park, No.158, Fuyuan 1st Road, Tangwei, Fuhai Subdistrict, Bao'an District, Shenzhen, Guangdong, China

TEL: 400-788-9558

P.C.: 518103

FAX: 0755-33229357

Website: <http://www.chnbctc.com>

E-Mail: [bctc@bctc-lab.com.cn](mailto:bctc@bctc-lab.com.cn)

\*\*\*\*\* END \*\*\*\*\*

