



Radxa ROCK Pi E

schematic

V3.0



Index

Page 1	01.Cover
Page 2	02.Index
Page 3	03.Block
Page 4	04.System Power-PMIC RK805-1
Page 5	05.RK3328 Power
Page 6	06.RK3328 OSC/PLL/OTP/SARADC
Page 7	07.RK3328 DDR Controler
Page 8	08.RK3328 FLASH Controler/TF
Page 9	09.RK3328 USB2 PHY/USB3 PHY
Page 10	10.RK3328 SDIO/UART/I2C/I2S/IR
Page 11	11.RK3328 HDMI PHY/FEPHY
Page 12	12.RK3328 AV Interface
Page 13	13.GMAC
Page 14	14.RAM DDR4 2x16bit
Page 15	15.TF/SD Card
Page 16	16.Flash-eMMC
Page 17	17.USB Port
Page 18	18.HDMI OUT Port
Page 19	19.WIFI+BT
Page 20	20.10/100M-Embed PHY
Page 21	21.CON



Size	Title: Radxa ROCK Pi E	REV
A4	Page Name: 02.Index	3.0
Date: Monday, May 20, 2024	Sheet 2 of 21	

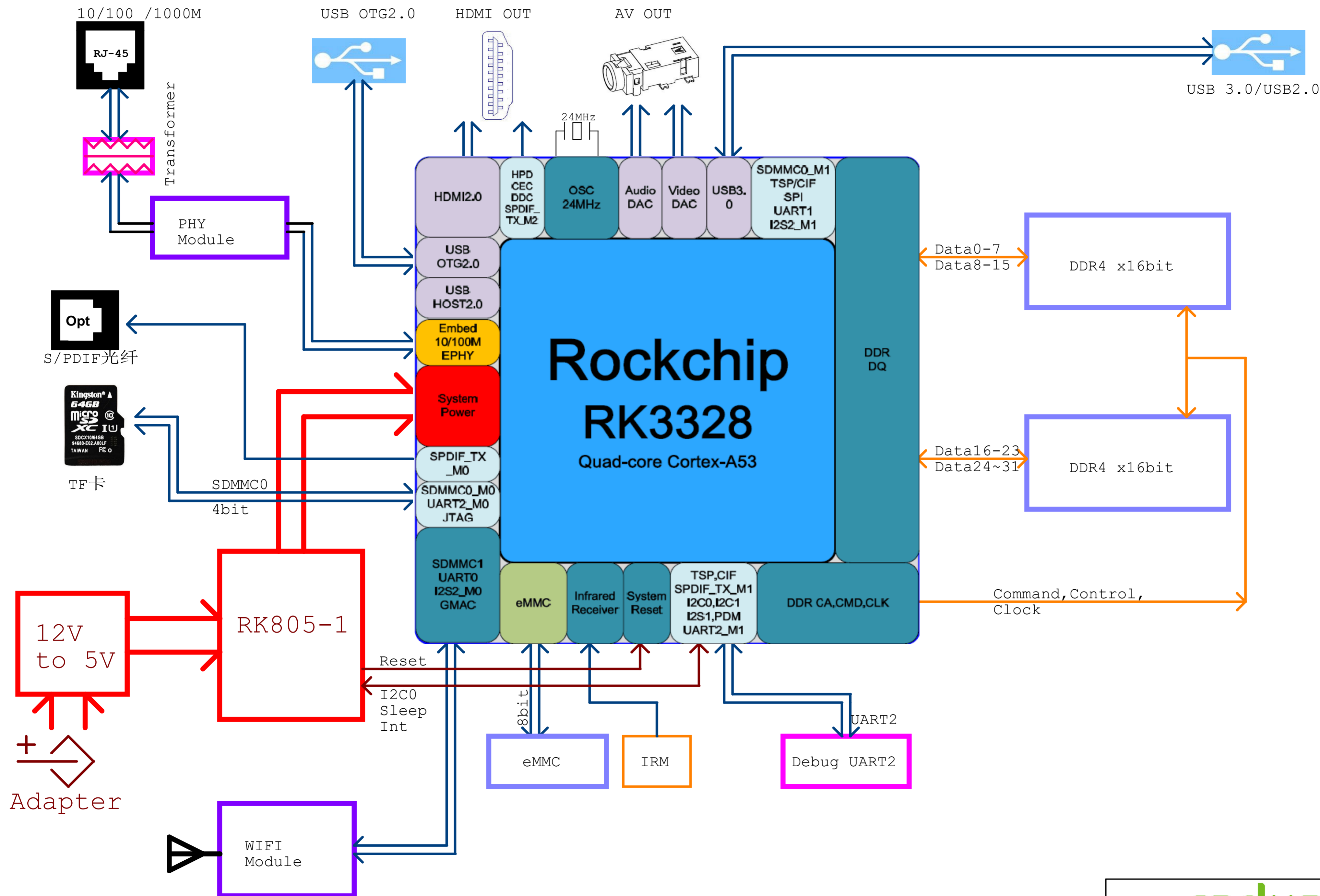

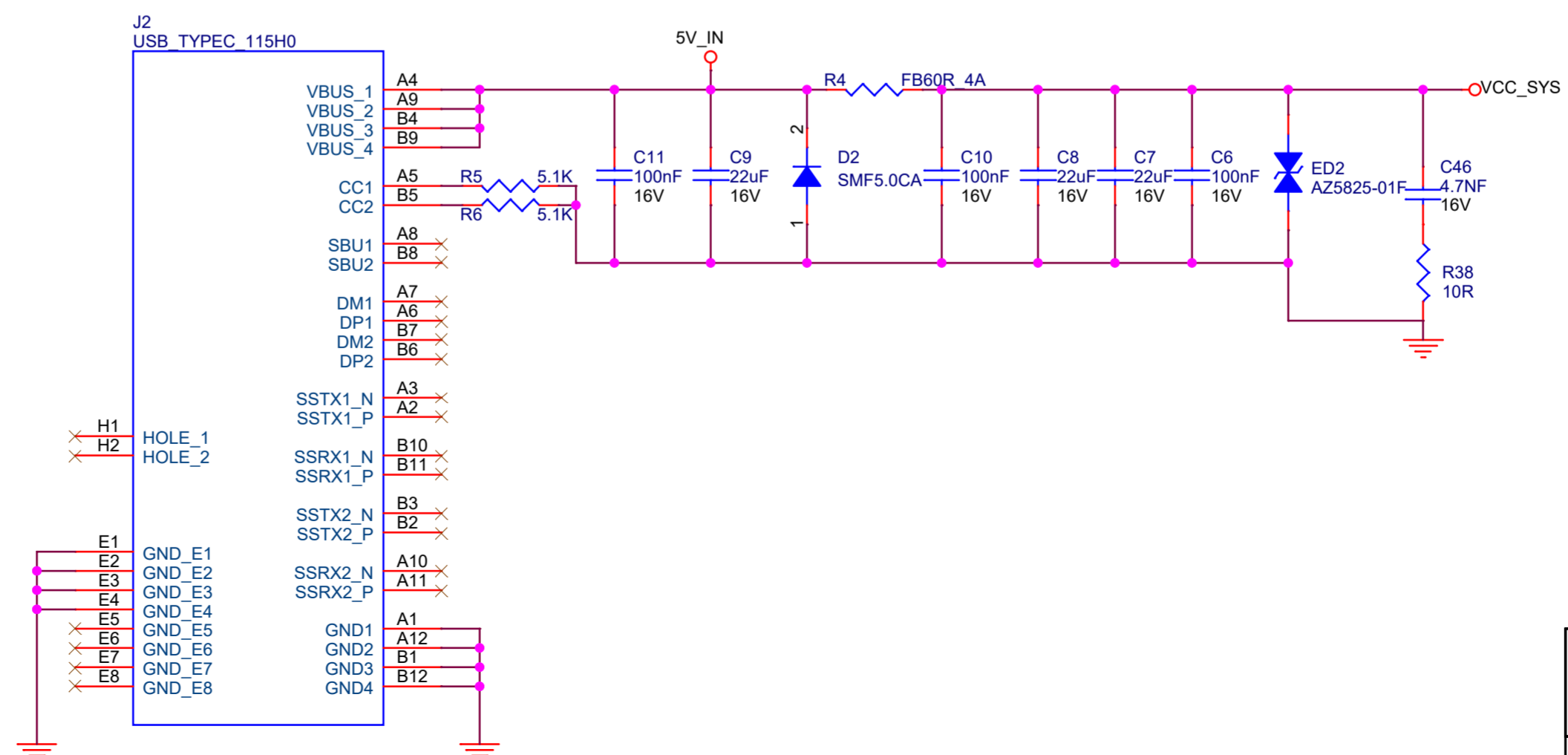
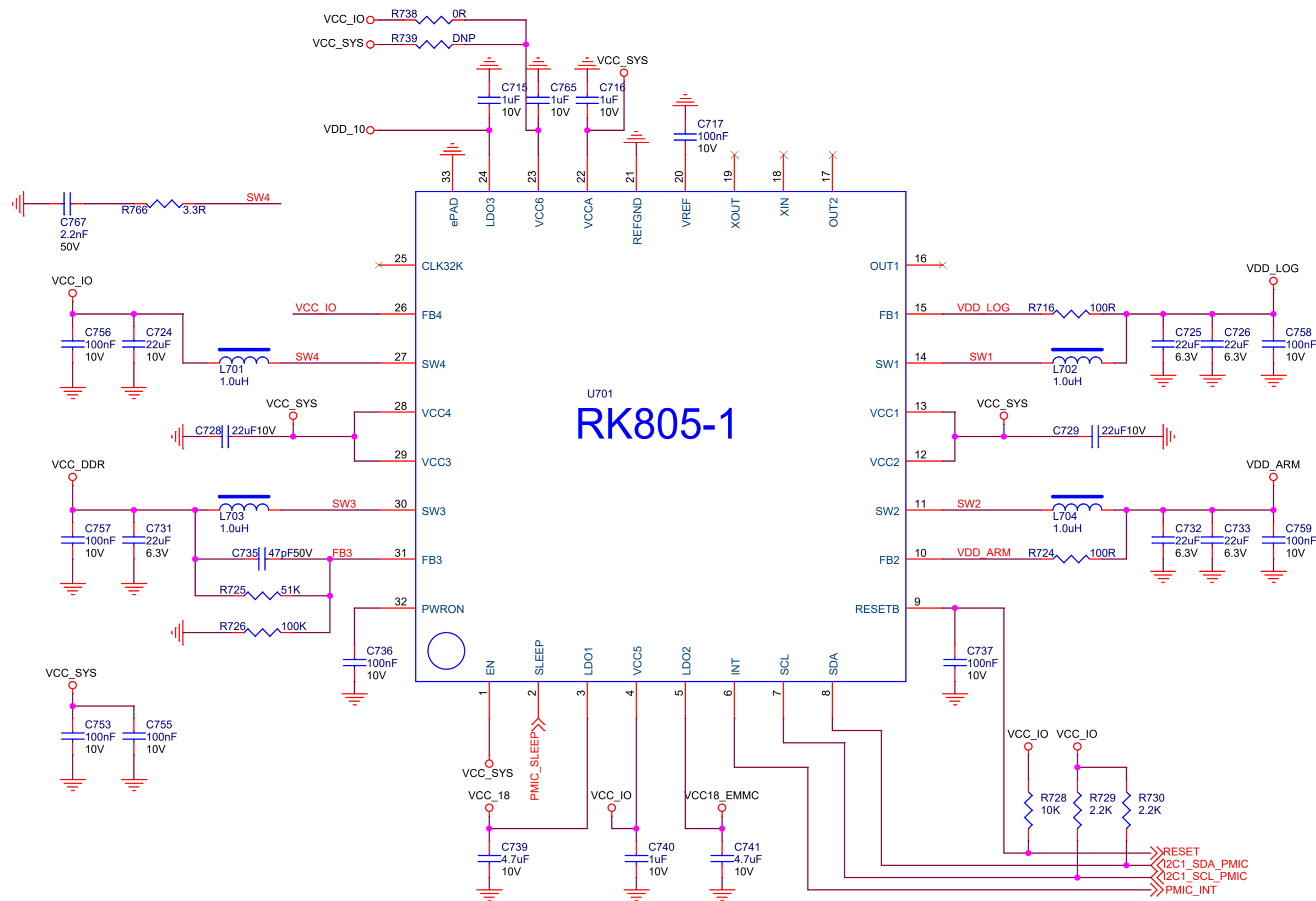

Size	Title: Radxa ROCK Pi E	REV
Custom	Page Name: 04.System Power-PMIC RK805-1	3.0
Date: Monday, May 20, 2024	Sheet 4 of 21	

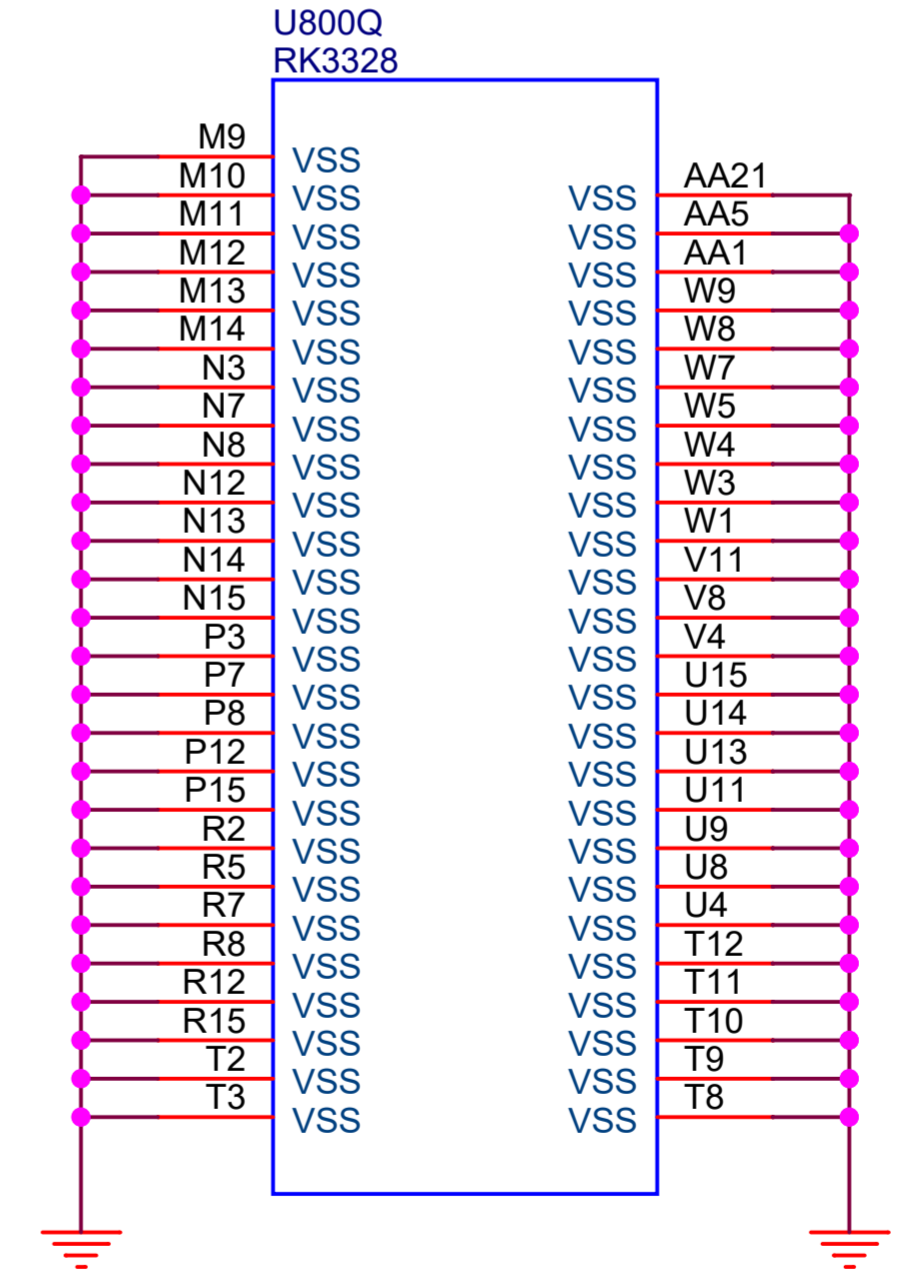
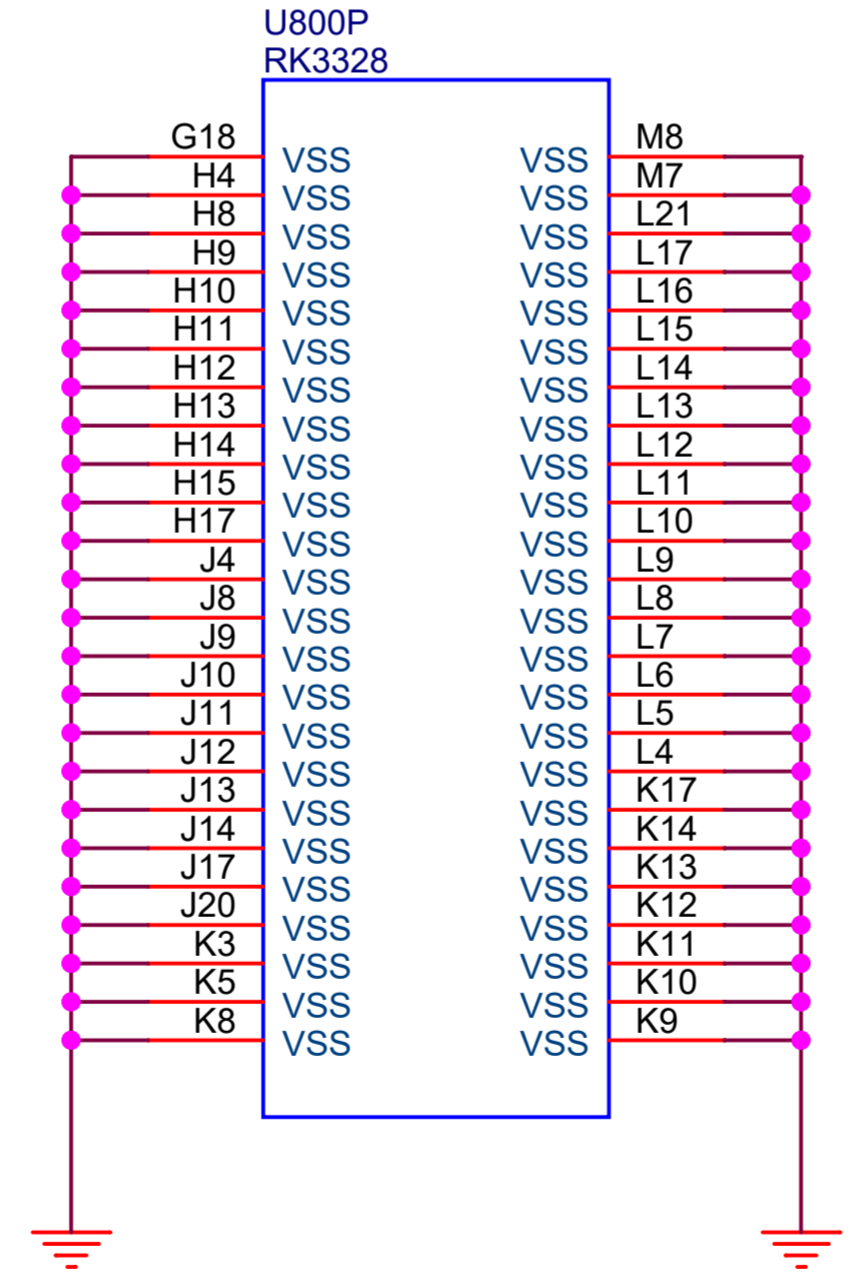
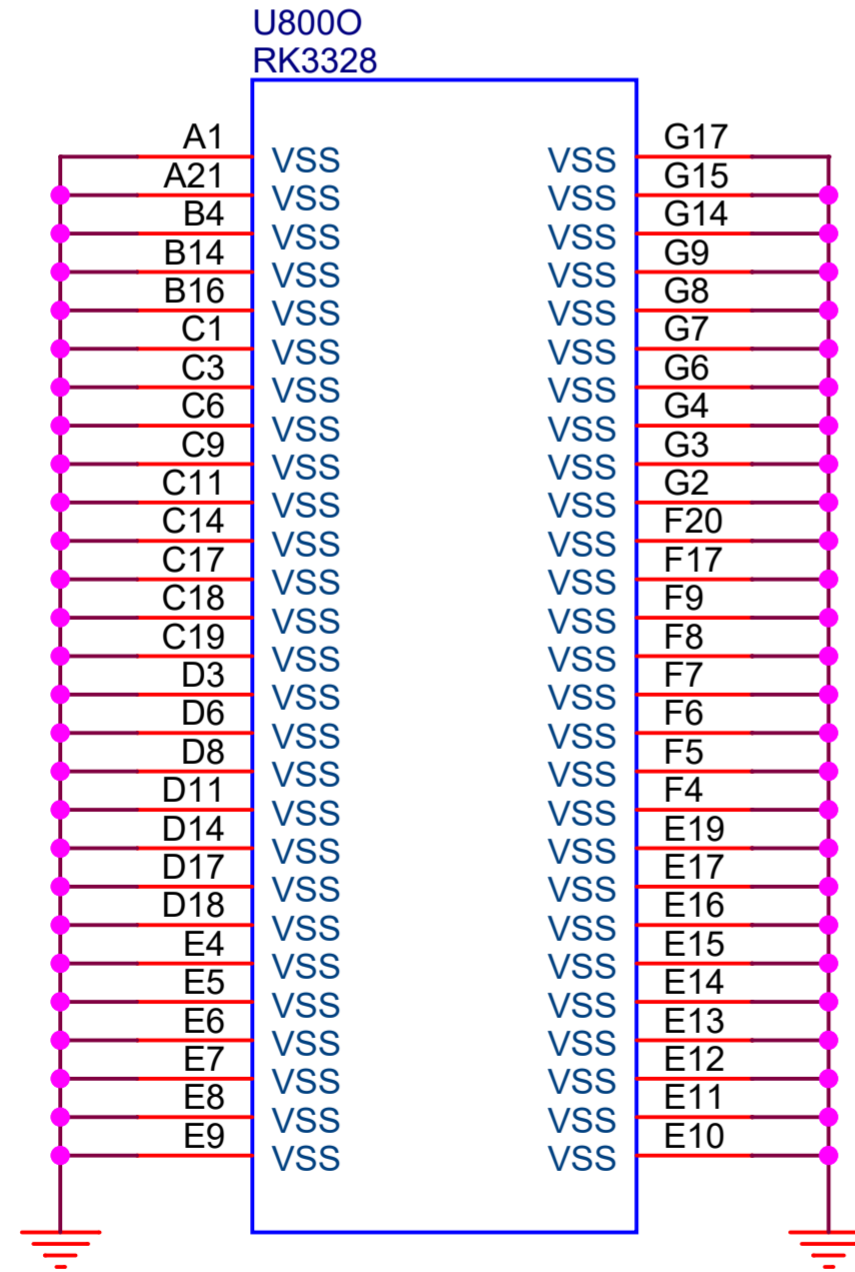
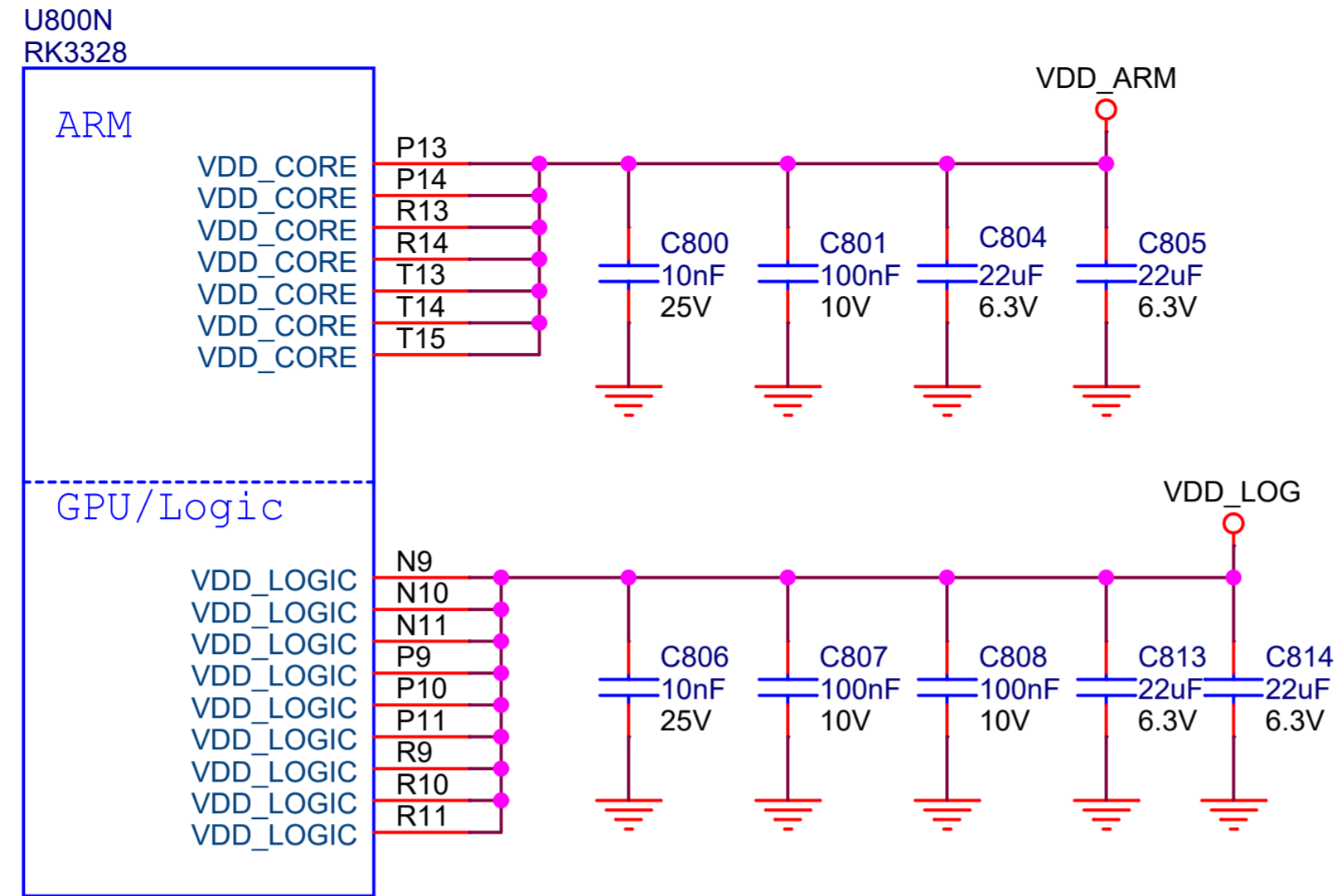

Size	Title: Radxa ROCK Pi E	REV
A4	Page Name: 05.RK3328 Power	3.0
Date: Monday, May 20, 2024	Sheet 5 of 21	

U800A
RK3328

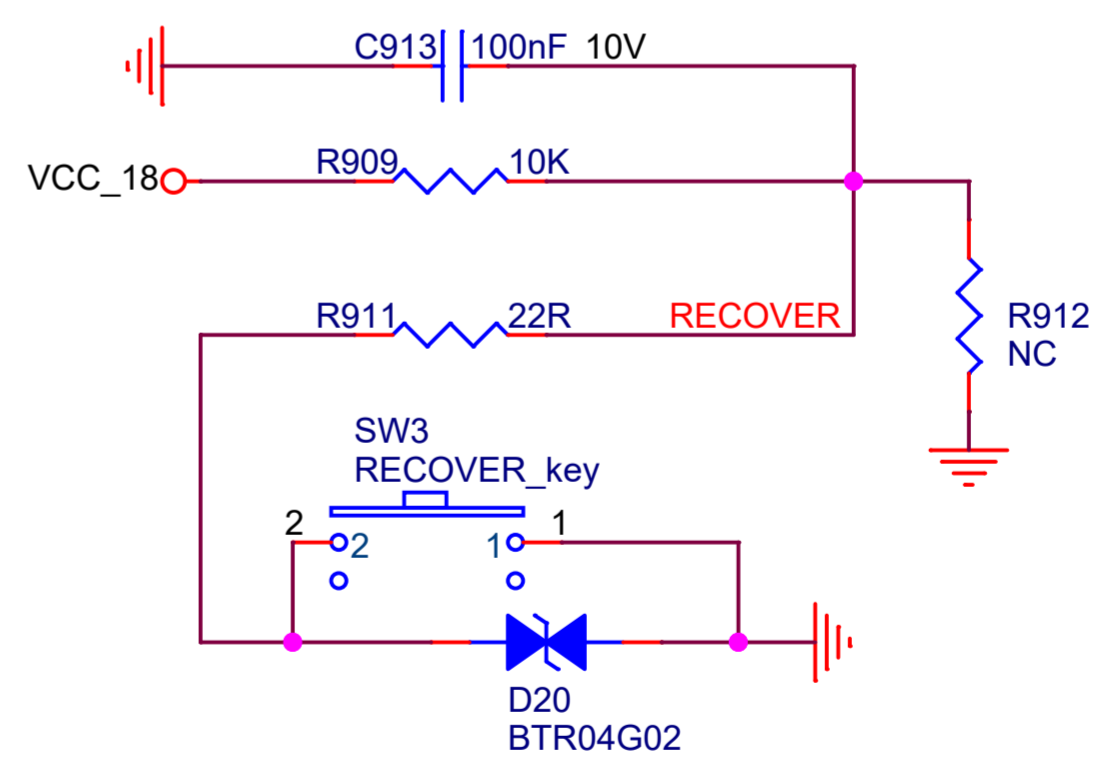
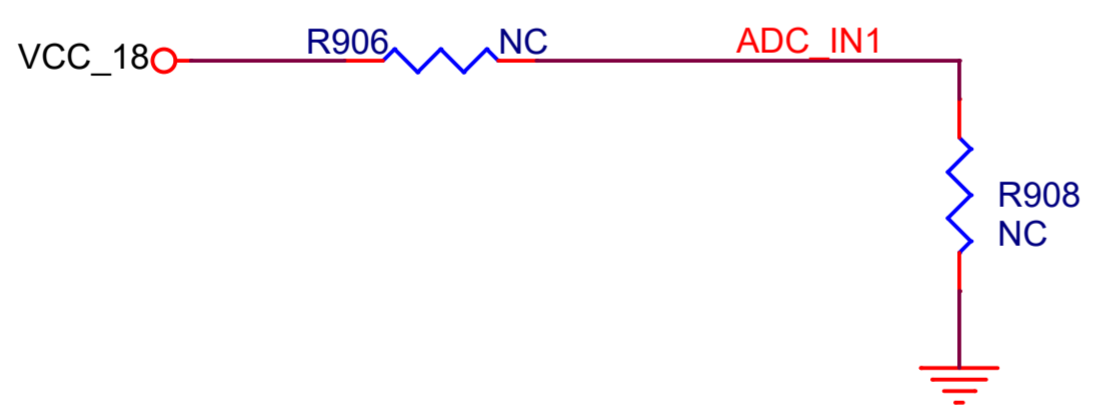
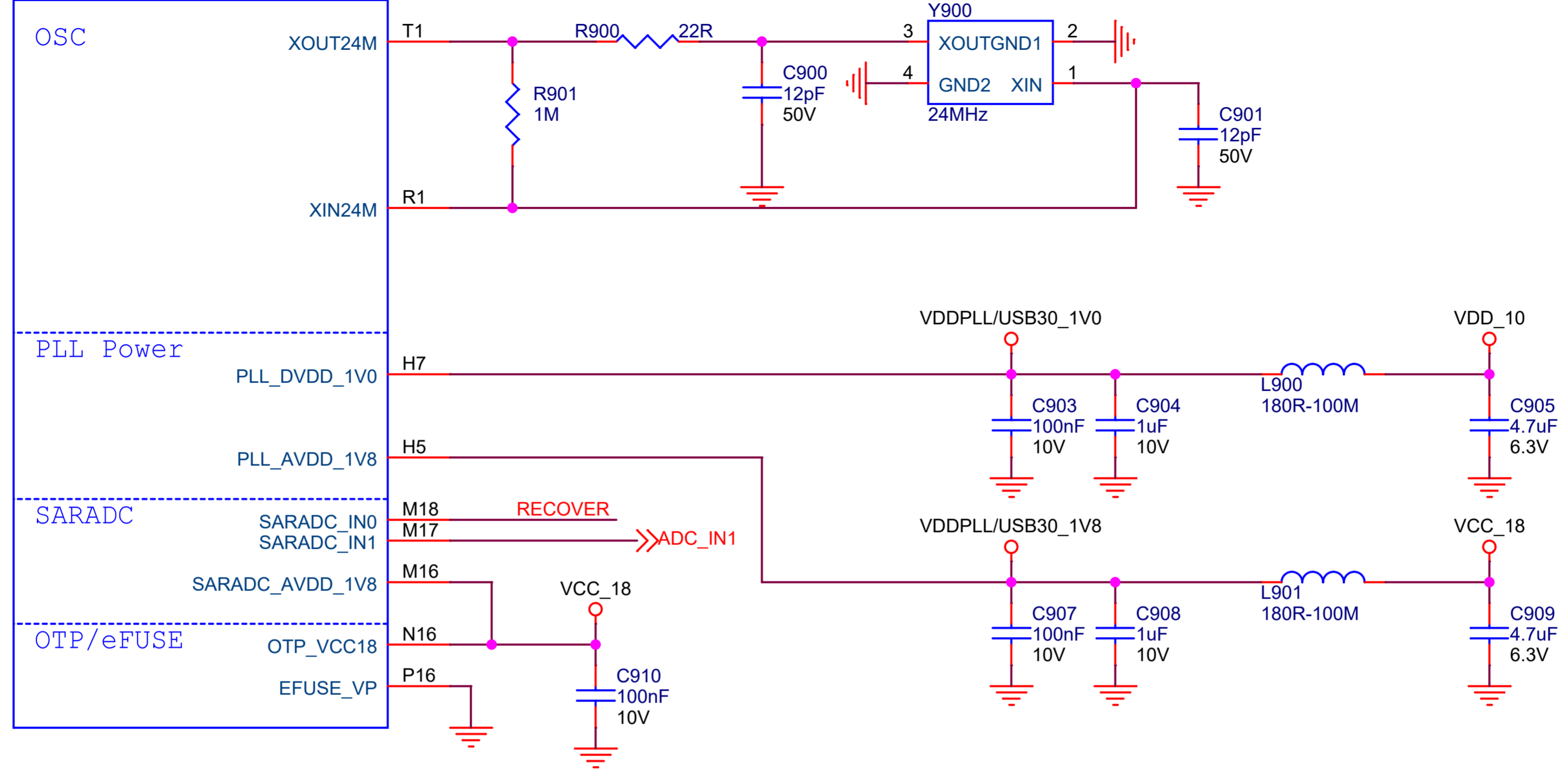

Size	Title: Radxa ROCK Pi E	REV
A4	Page Name: 06.RK3328 OSC/PLL/OTP/SARADC	3.0
Date: Monday, May 20, 2024	Sheet 6 of 21	

U800M
RK3328

DDR3/DDR4

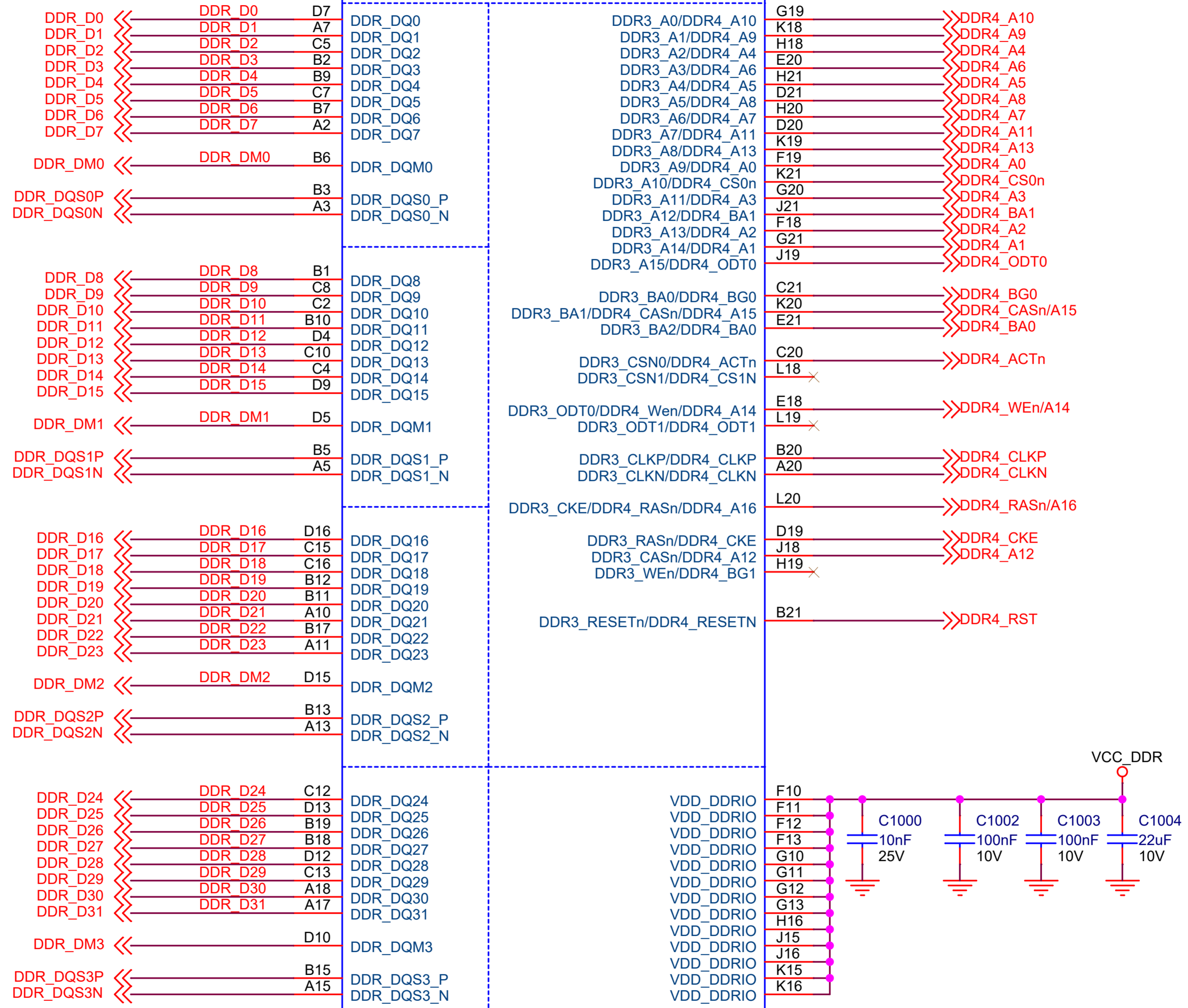

Size	Title: Radxa ROCK Pi E	REV
A4	Page Name: 07.RK3328 DDR Controler	3.0
Date: Monday, May 20, 2024	Sheet 7 of 21	

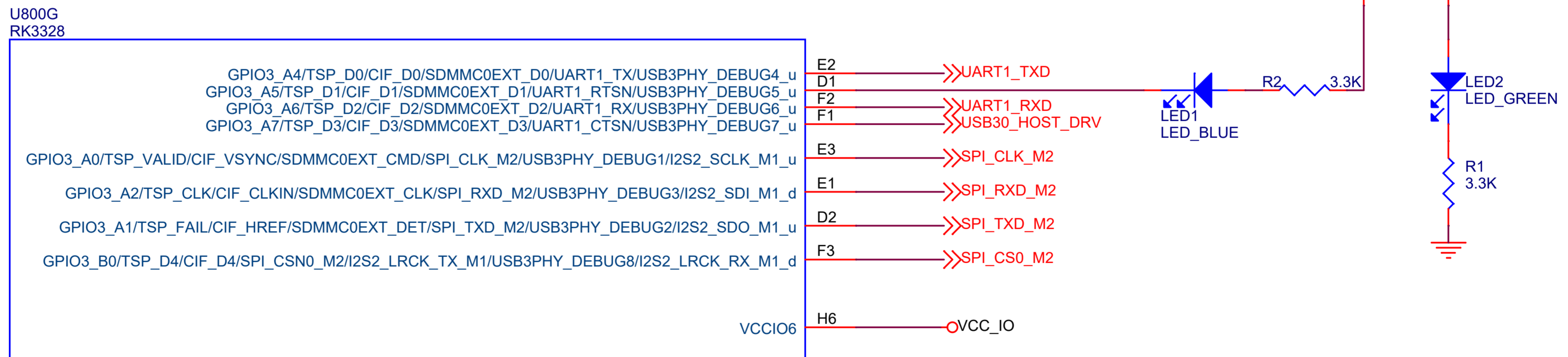
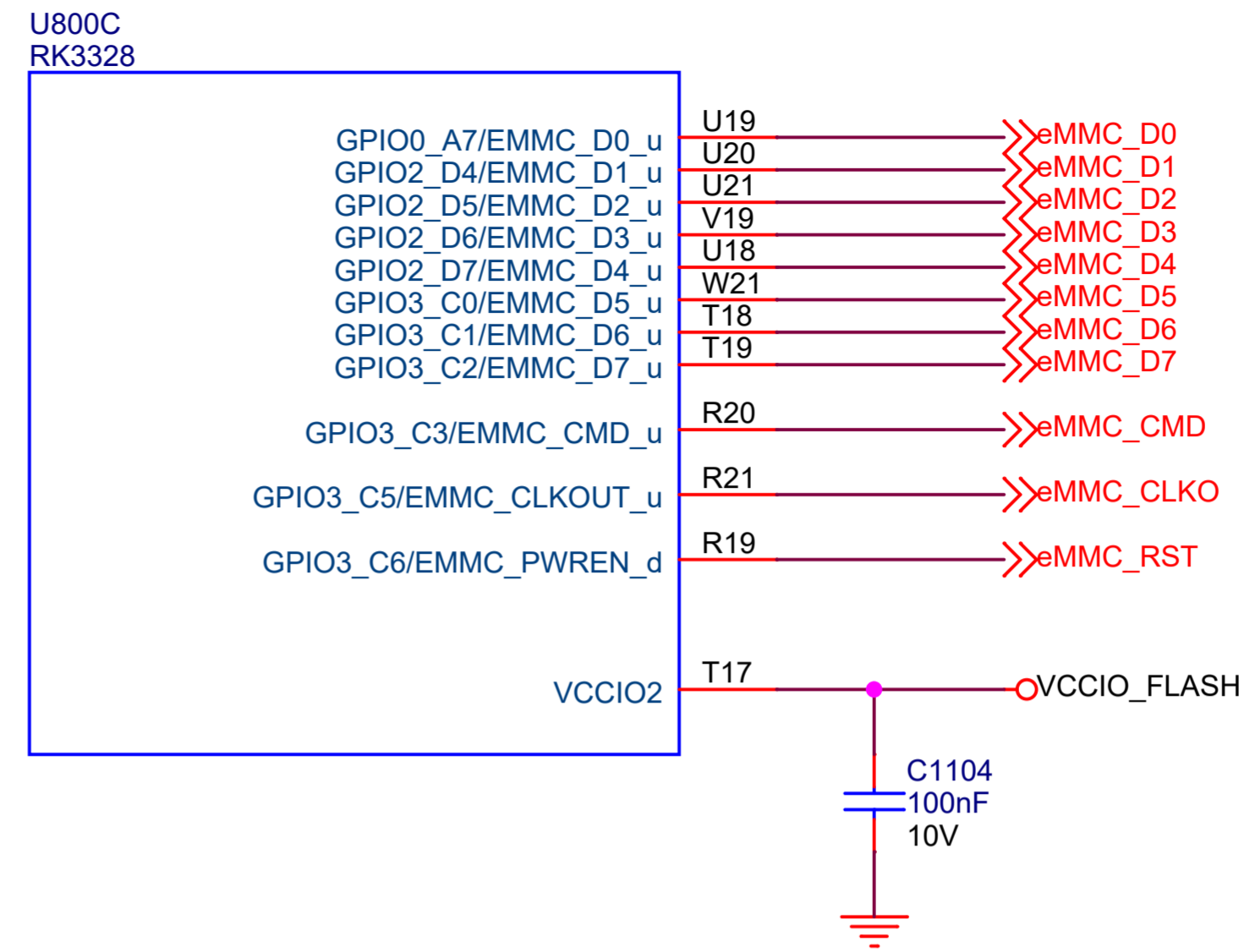
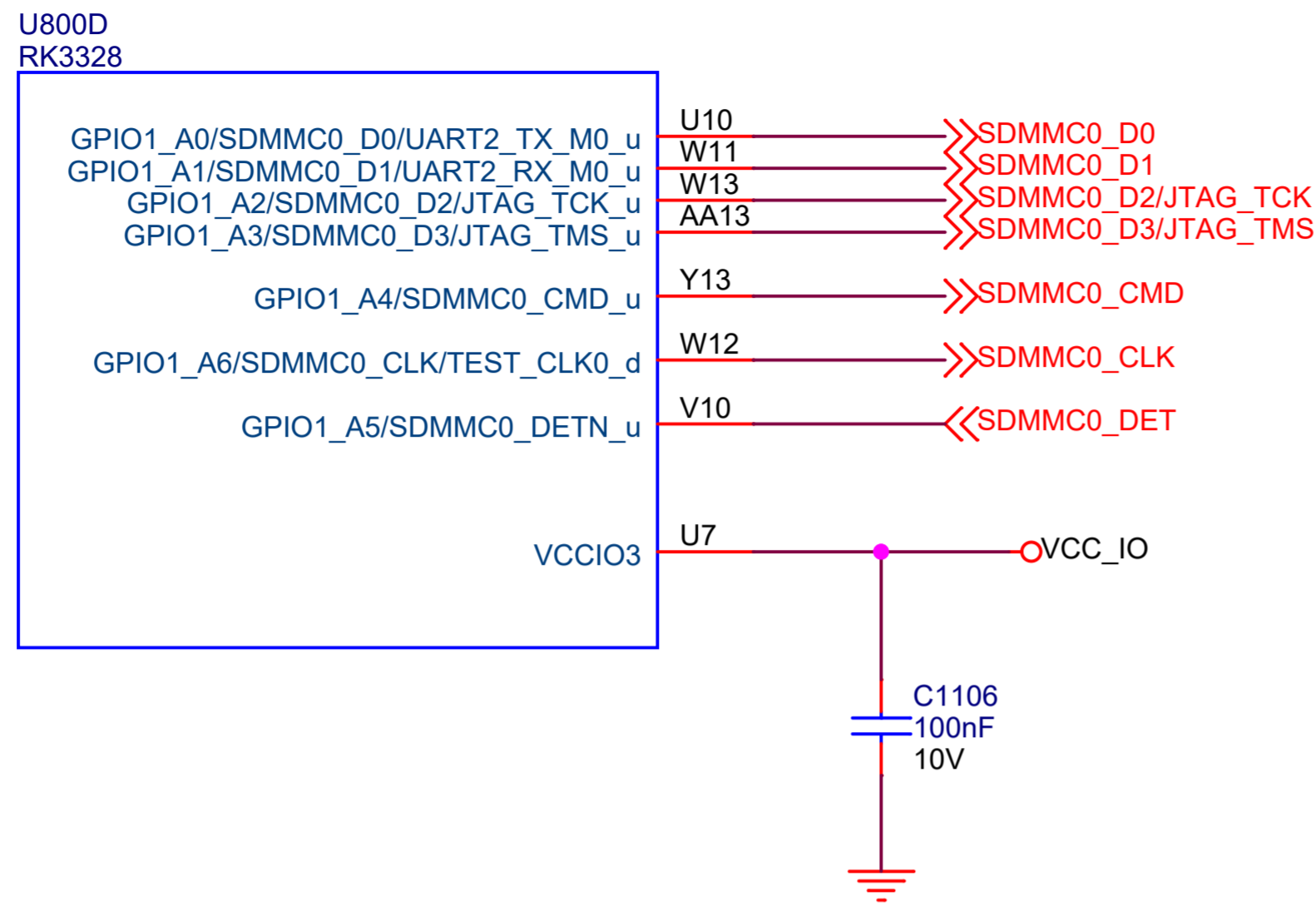

Size	Title: Radxa ROCK Pi E	REV
A4	Page Name: 08.RK3328 FLASH Controller/TF	3.0
Date: Monday, May 20, 2024	Sheet 8 of 21	

U800K
RK3328

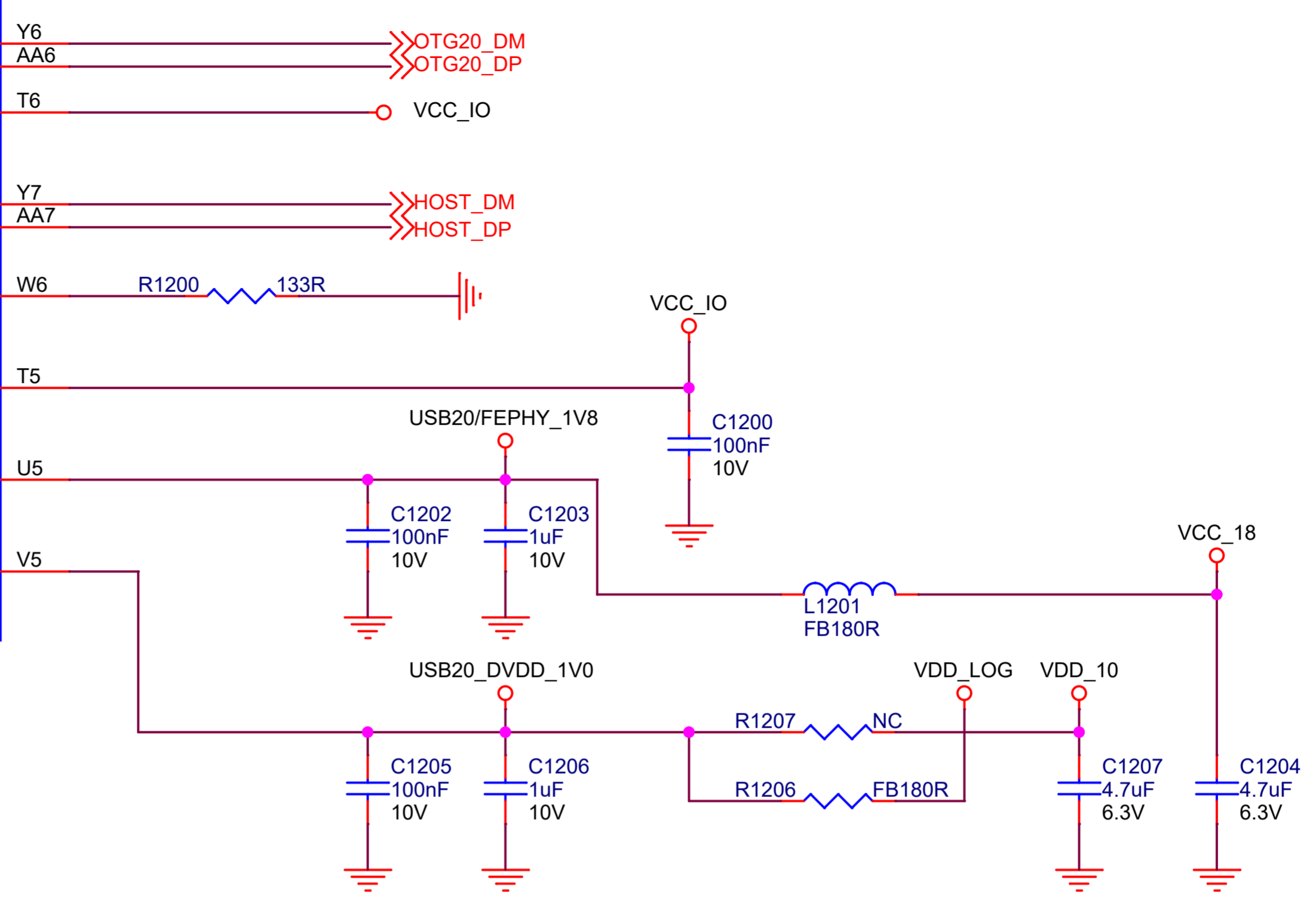
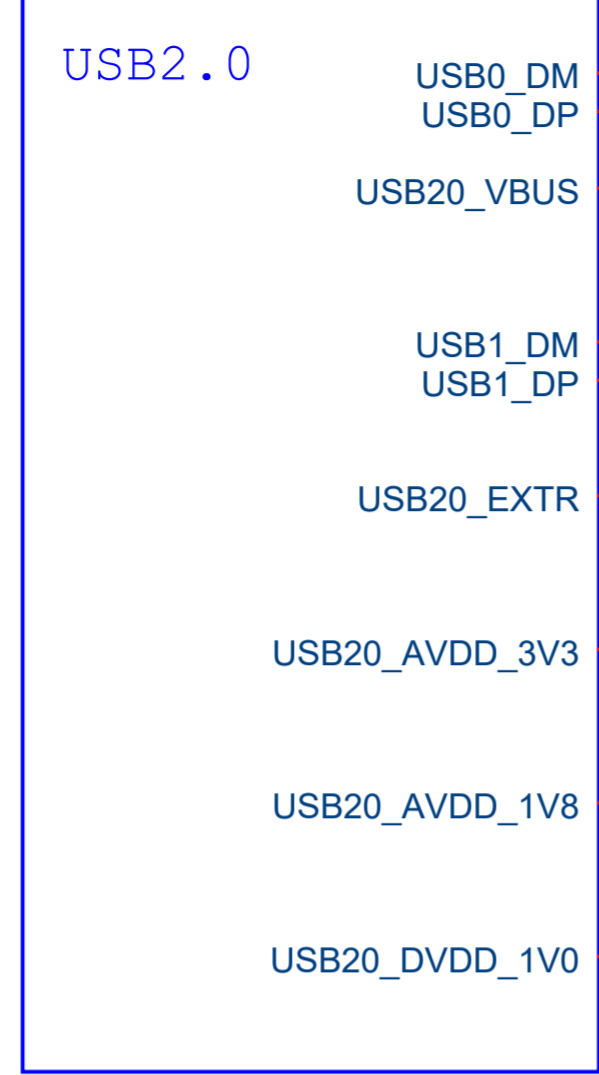

U800L
RK3328

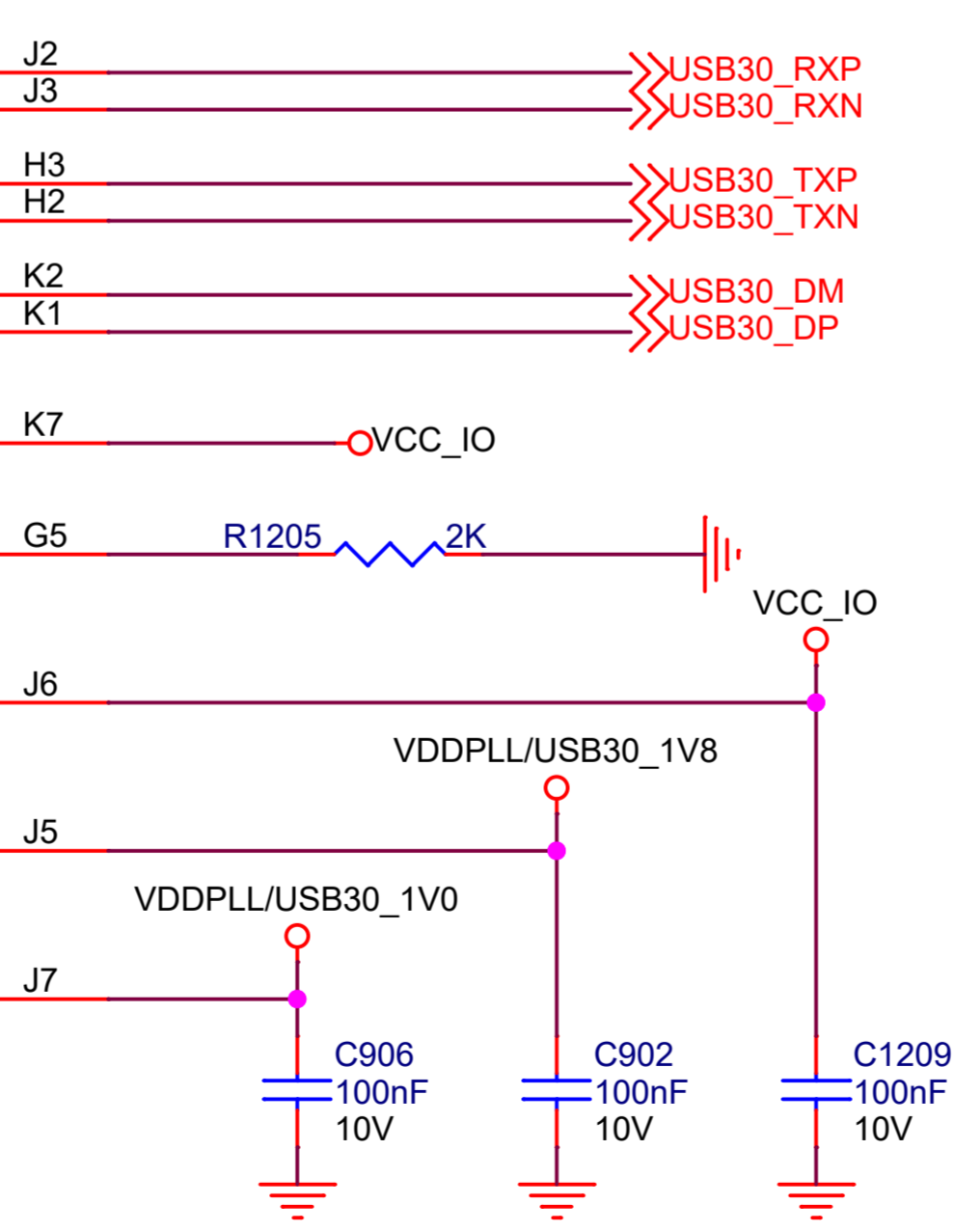
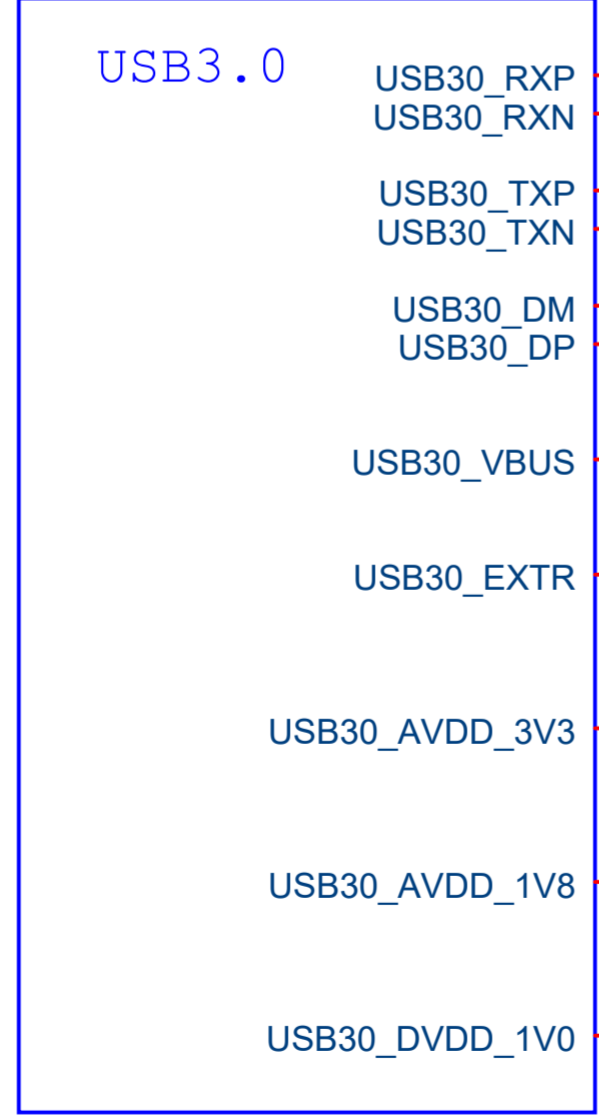

Size	Title: Radxa ROCK Pi E	REV
A4	Page Name: 09.RK3328 USB2 PHY/USB3 PHY	3.0
Date: Monday, May 20, 2024	Sheet 9 of 21	

U800F
RK3328

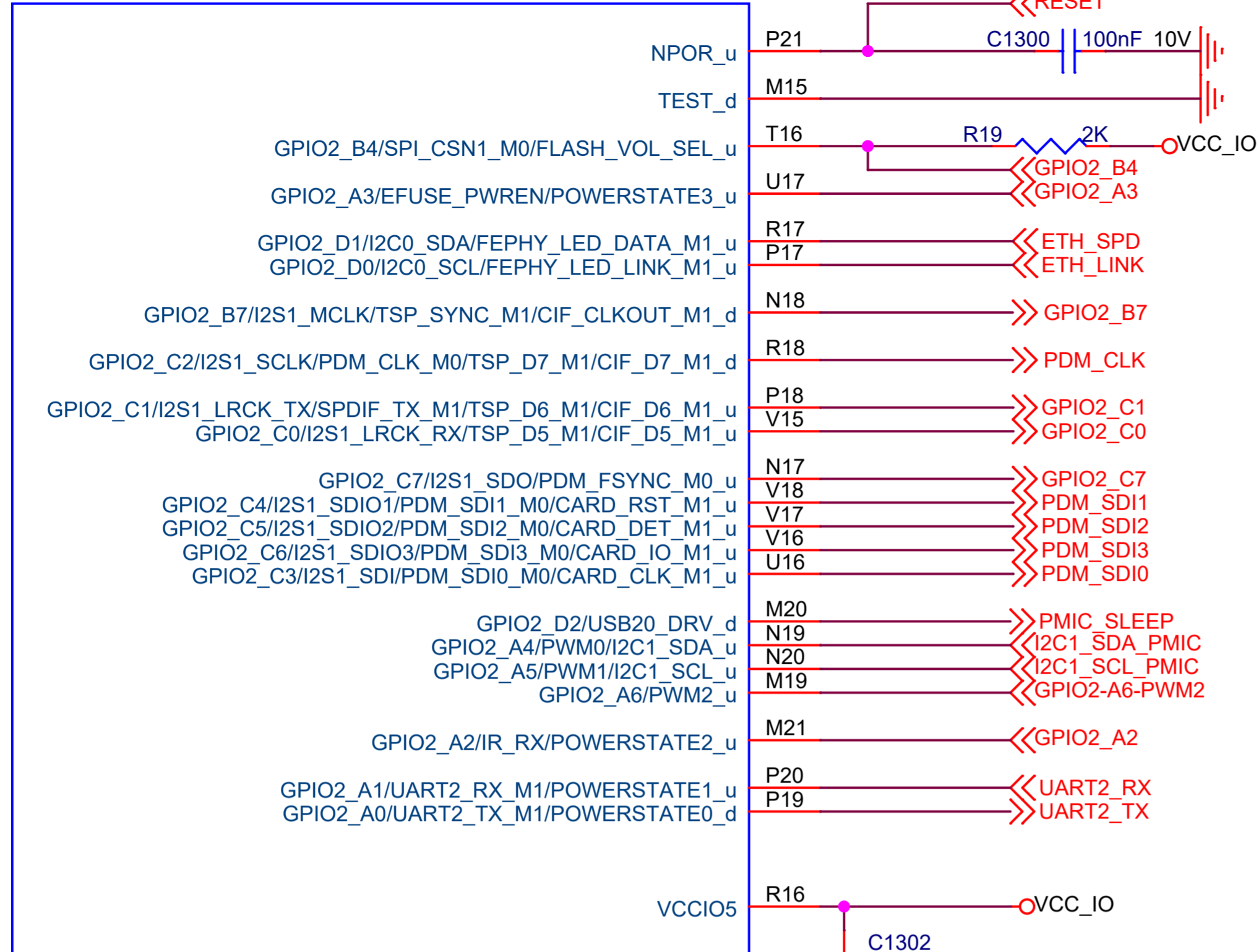

U800E
RK3328

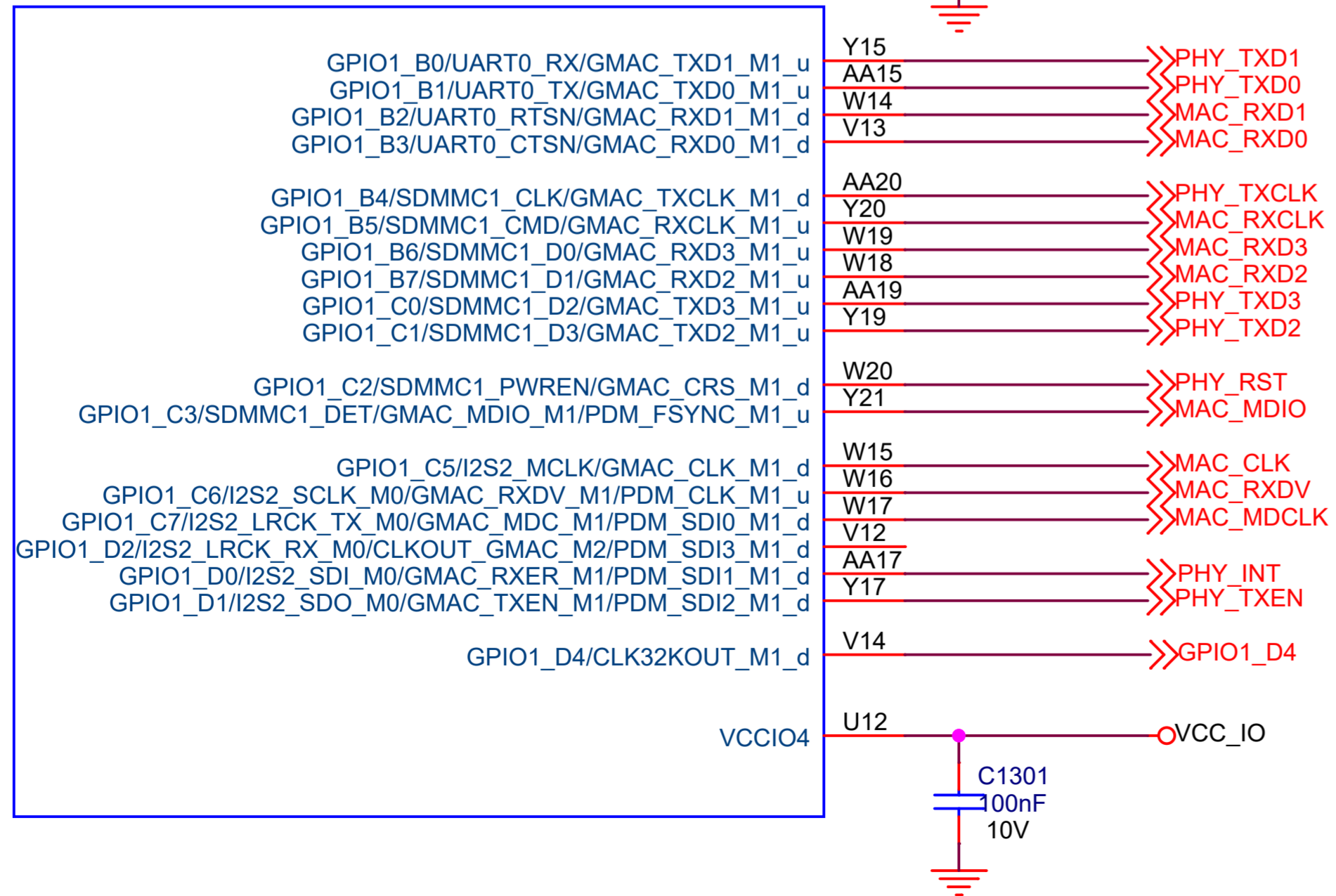

U800B
RK3328

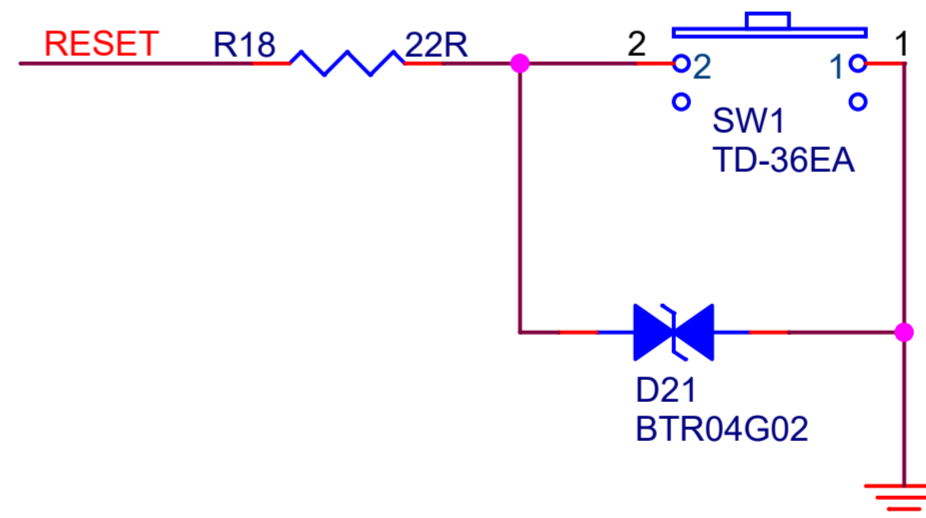
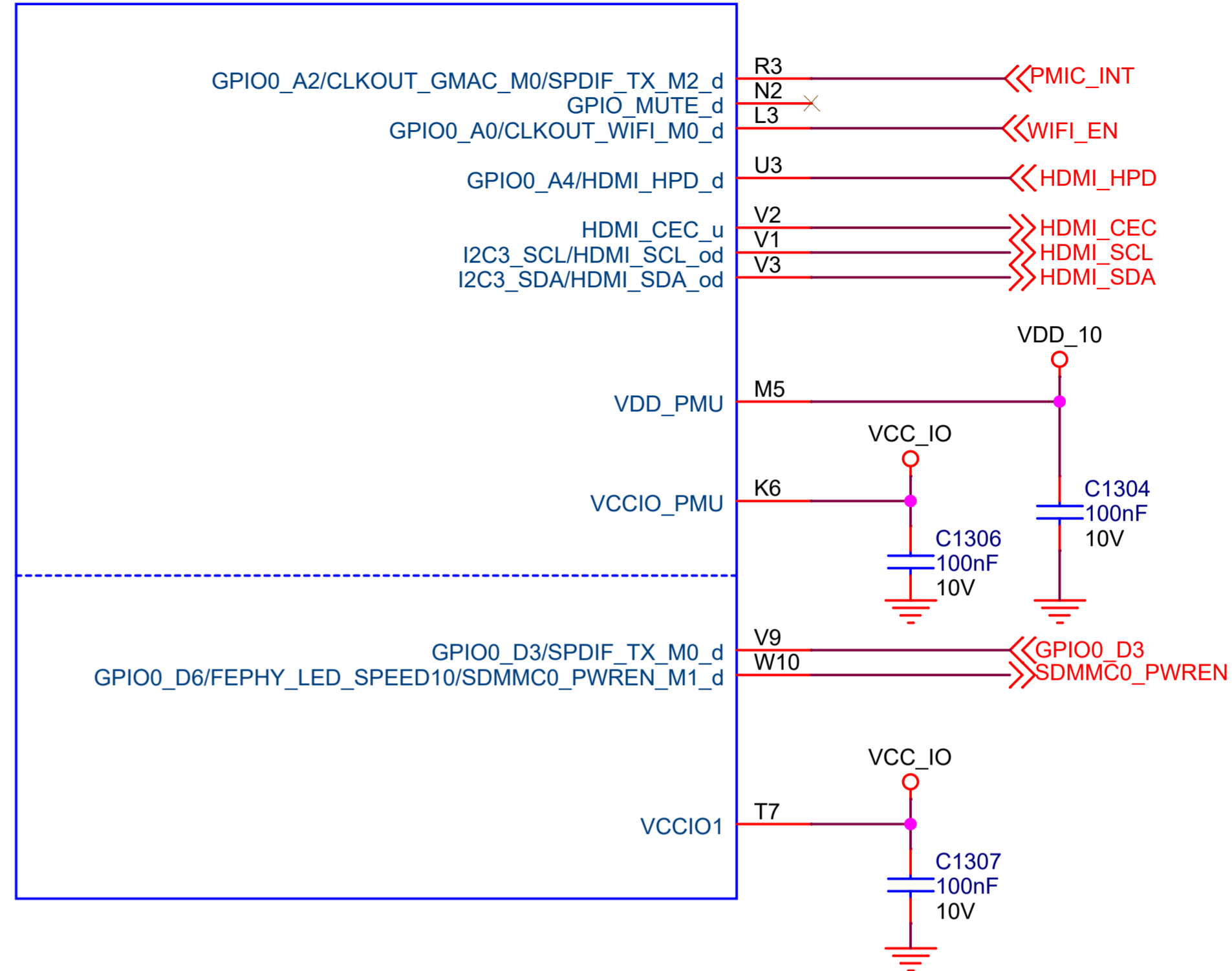

Size	Title: Radxa ROCK Pi E	REV
A4	Page Name: 10.RK3328 SDIO/UART/I2C/I2S/IR	3.0
Date: Monday, May 20, 2024	Sheet 10 of 21	

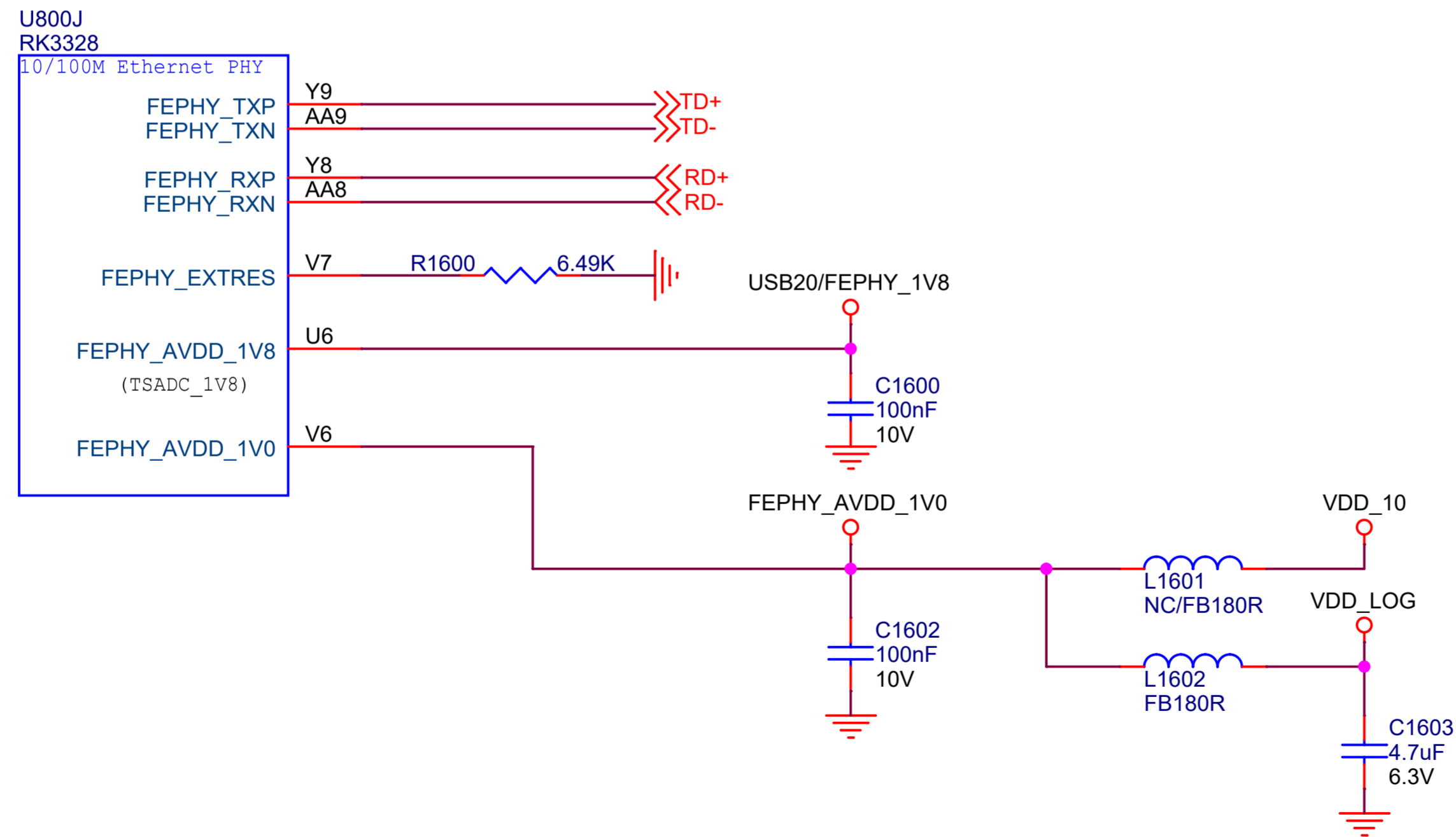
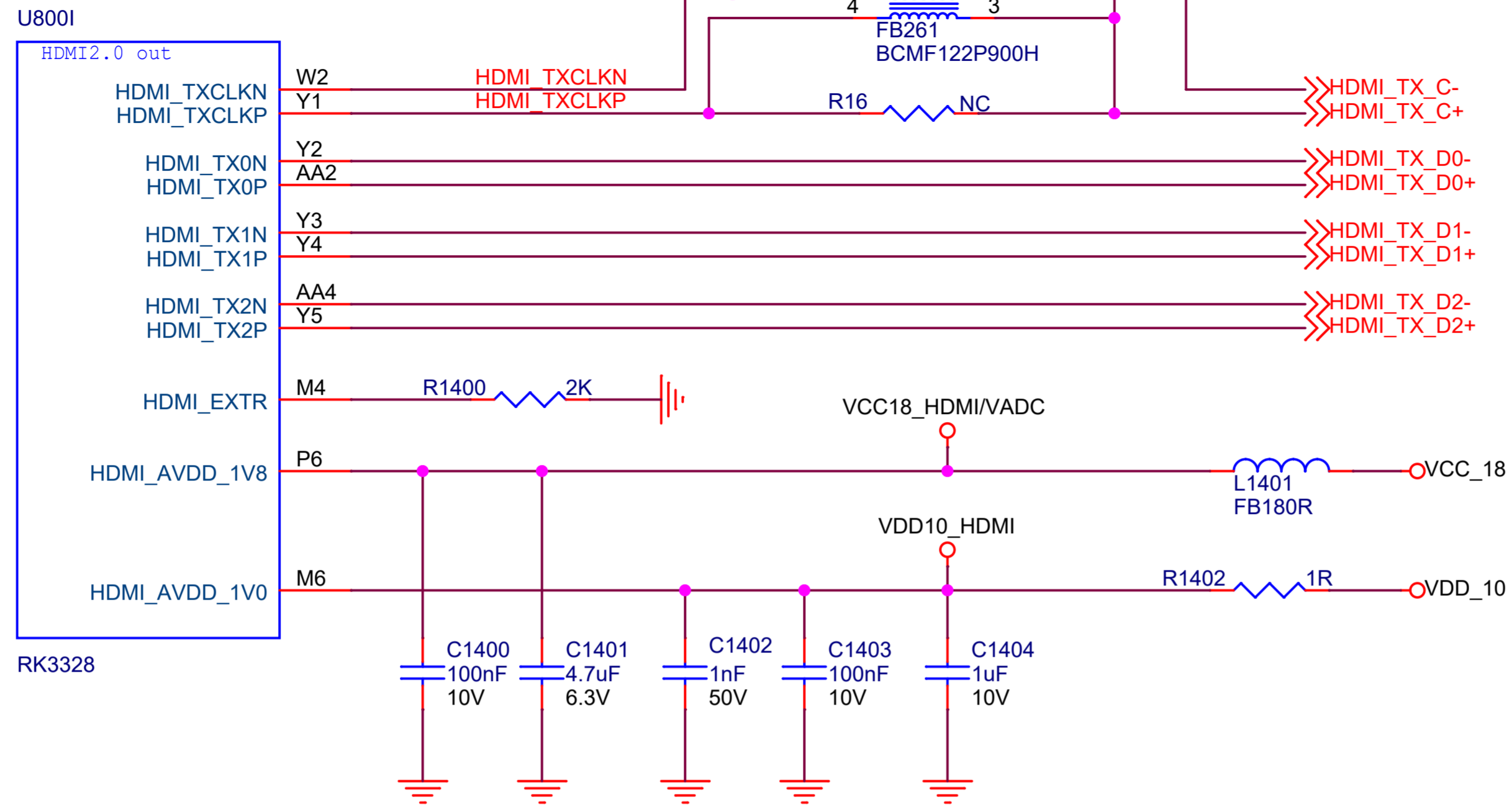

Size	Title: Radxa ROCK Pi E	REV
A4	Page Name: 11.RK3328 HDMI PHY/FEPHY	3.0
Date: Monday, May 20, 2024	Sheet 11 of 21	

U800H
RK3328

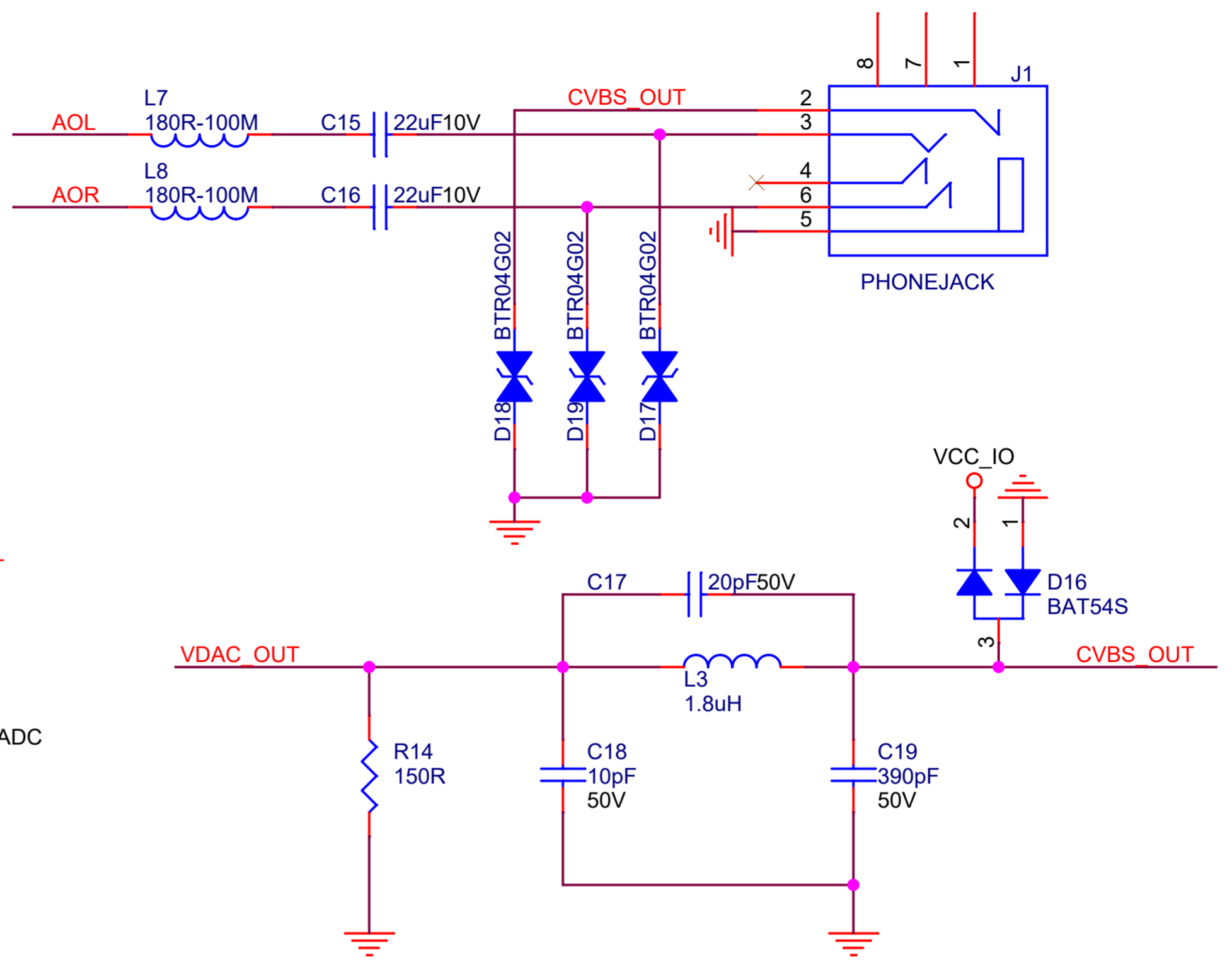
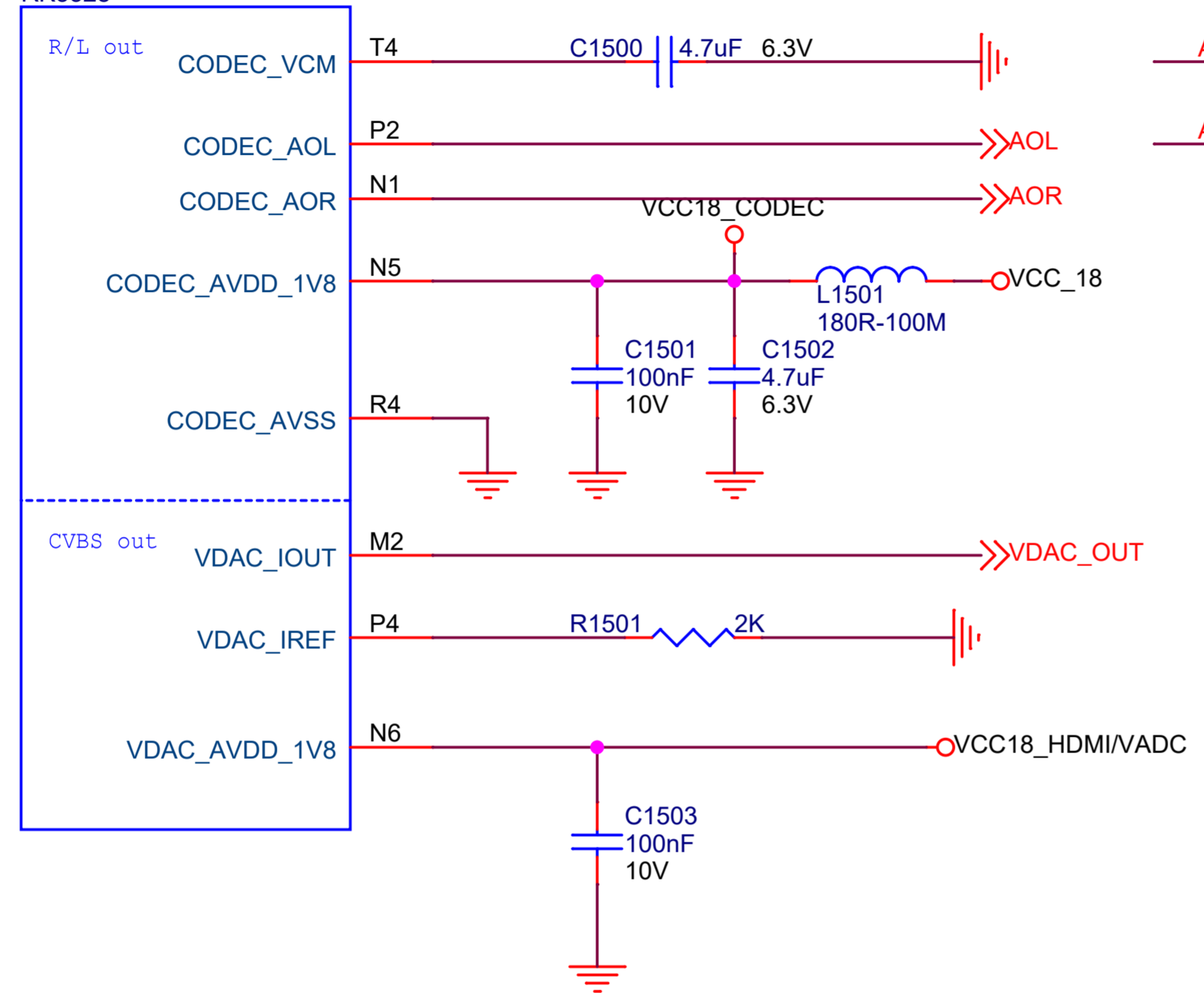

Size	Title: Radxa ROCK Pi E	REV
A4	Page Name: 12.RK3328 AV Interface	3.0
Date: Monday, May 20, 2024	Sheet 12 of 21	

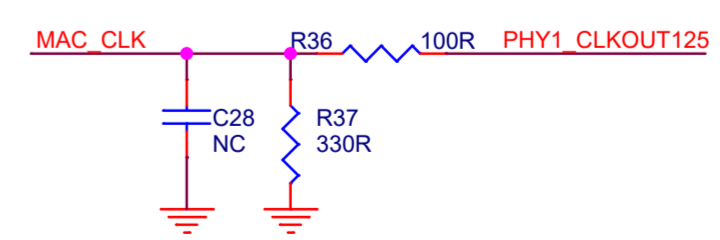
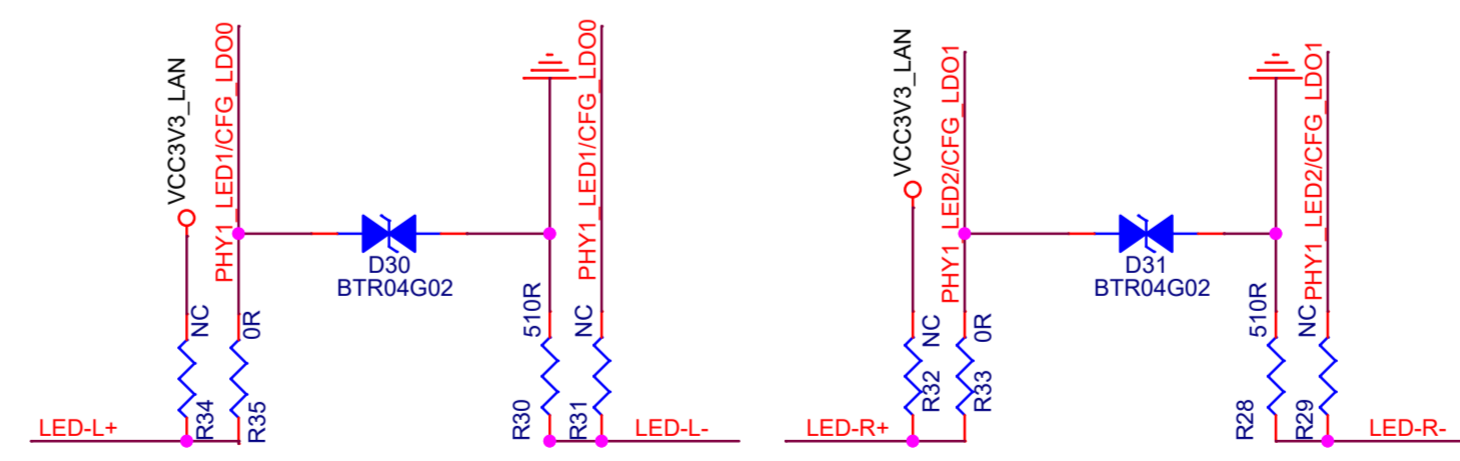
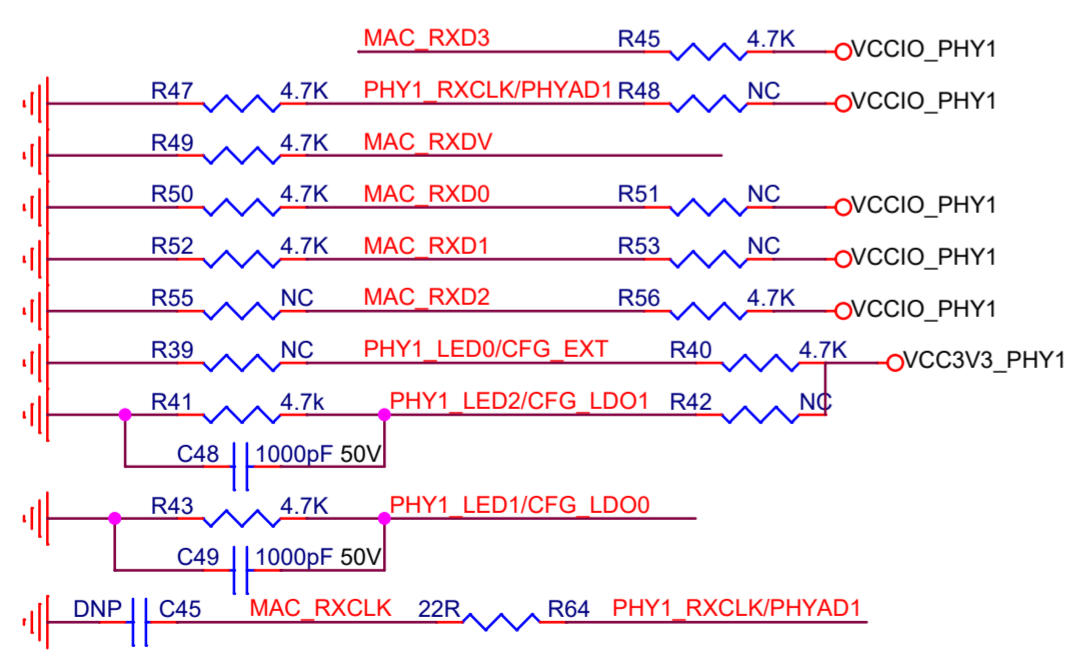
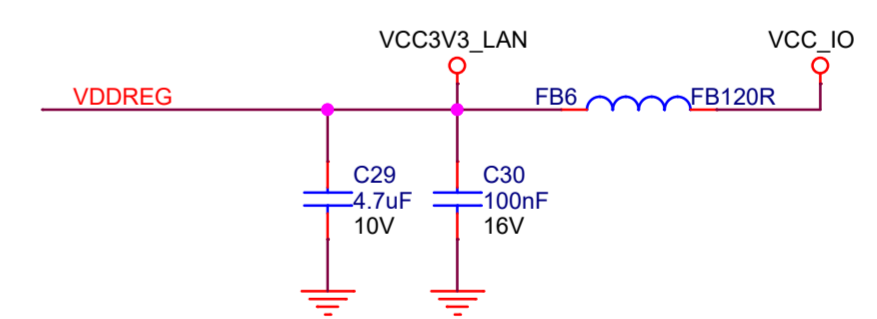
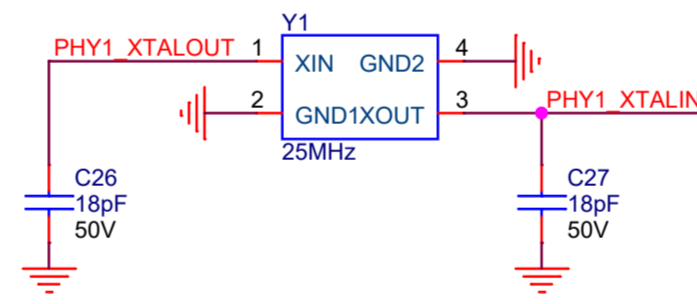
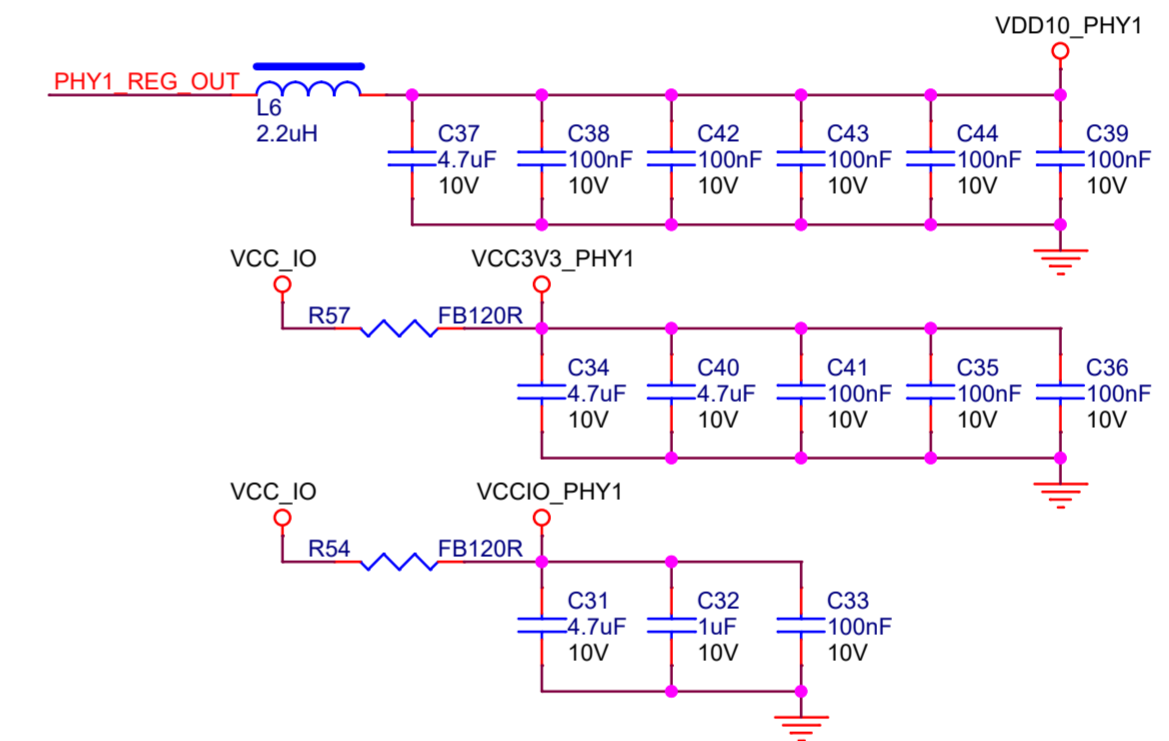
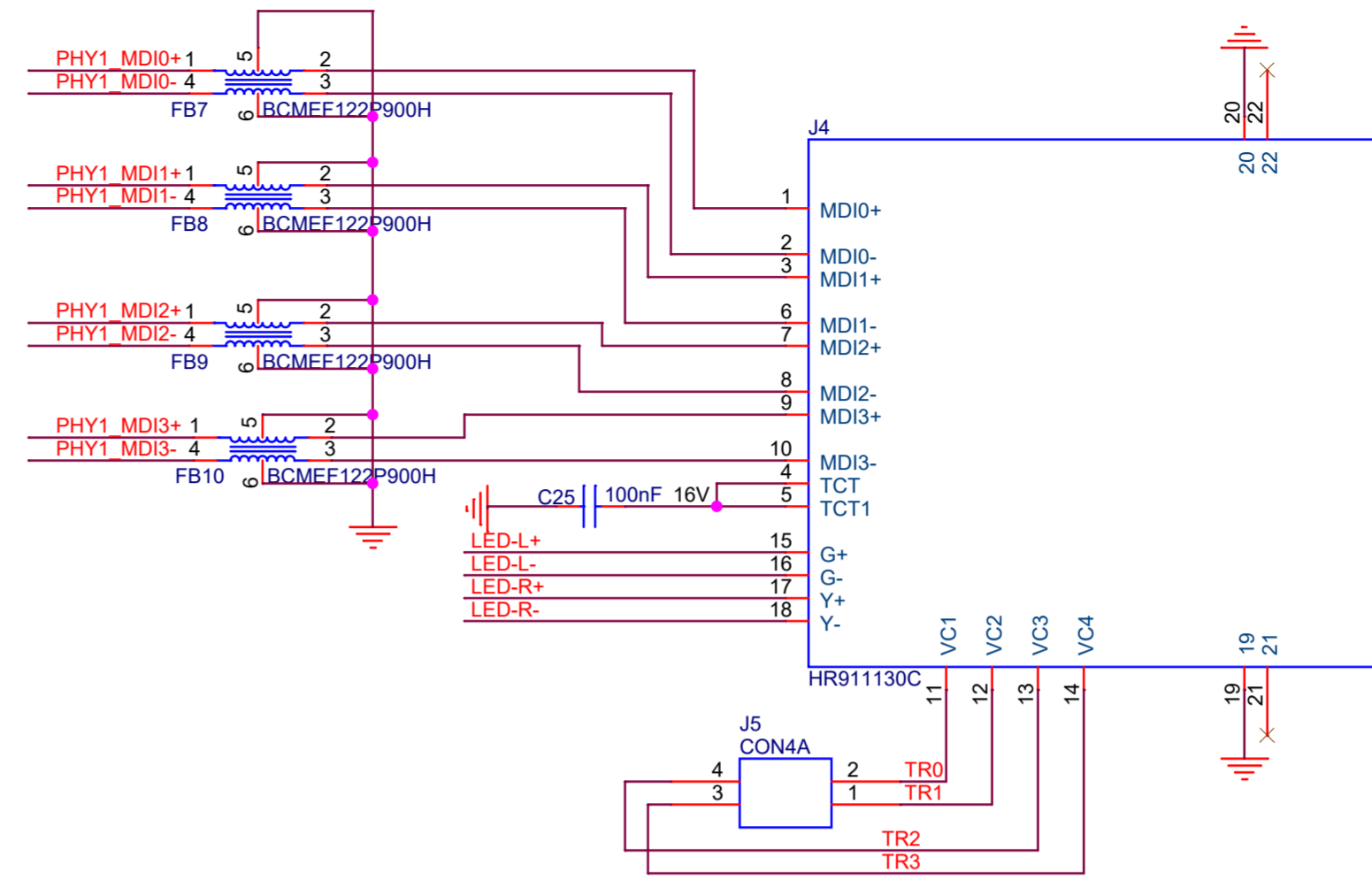
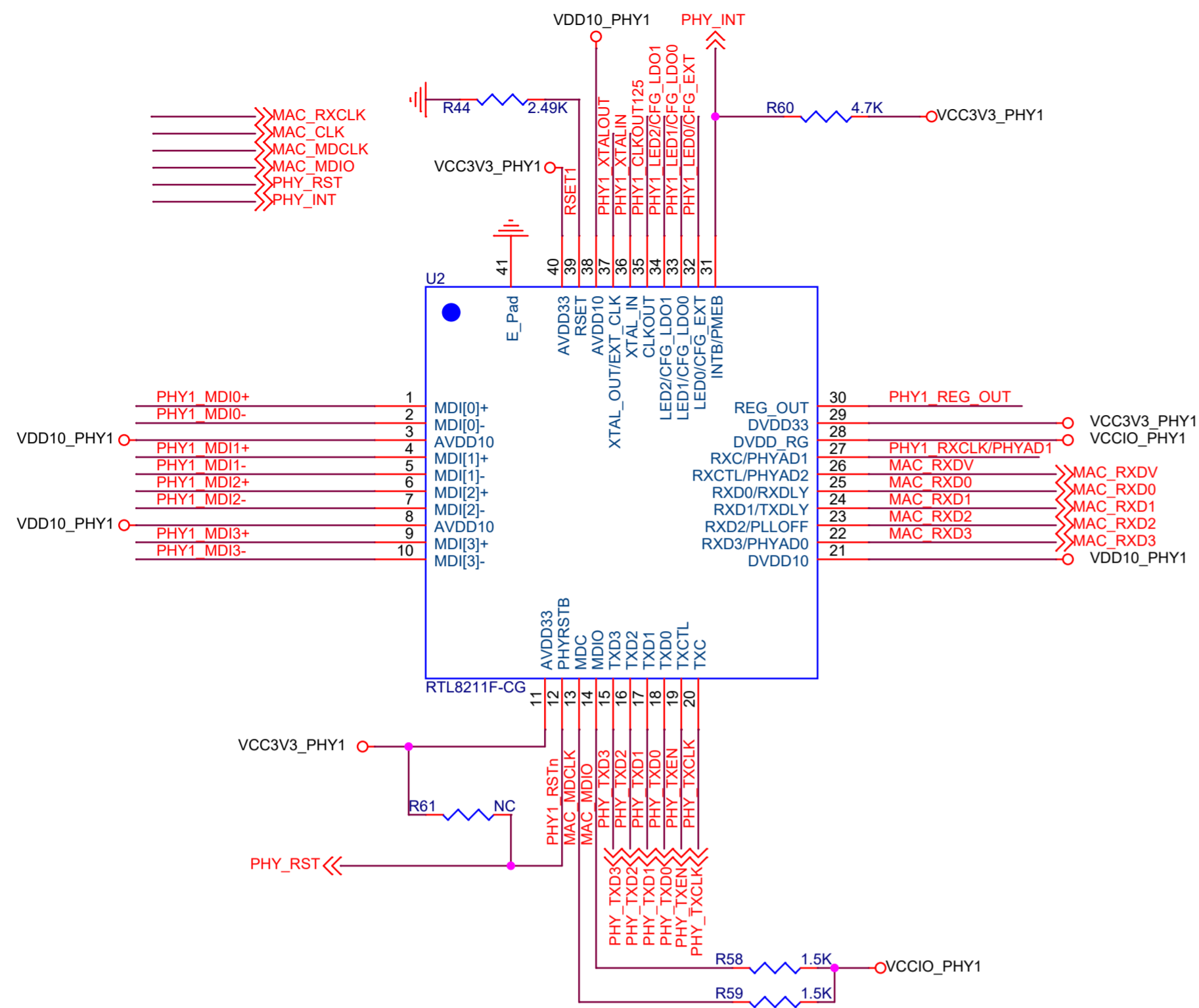

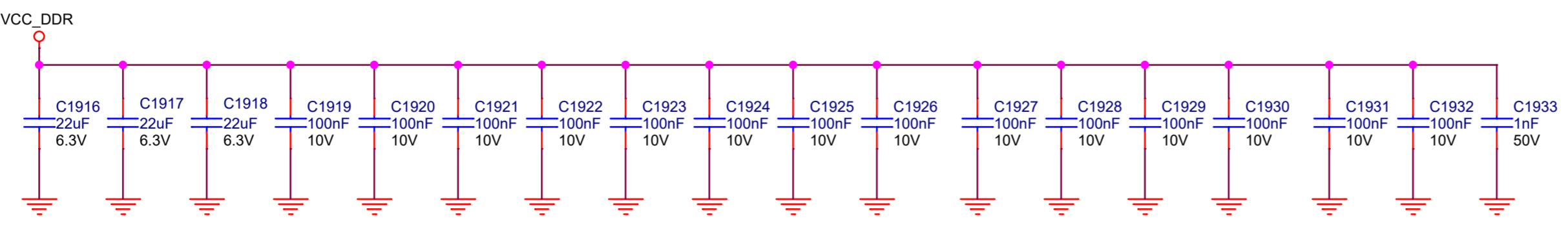
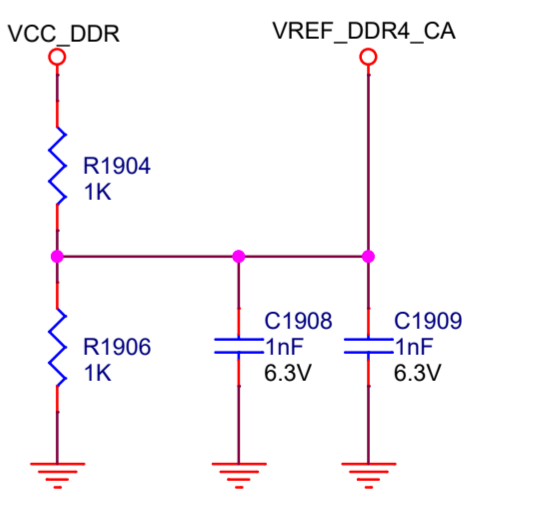
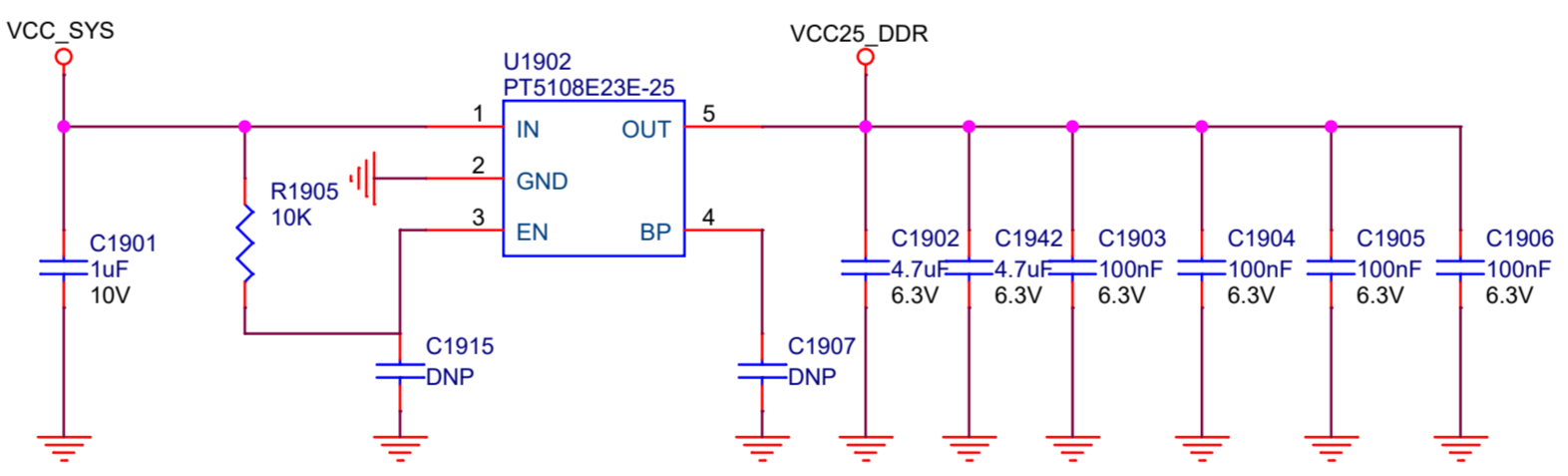
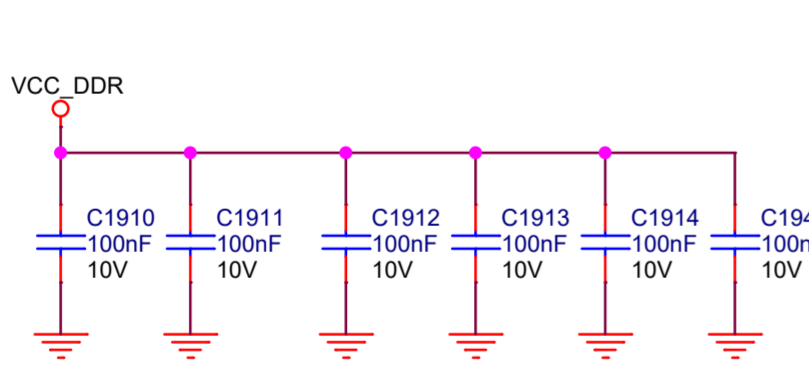
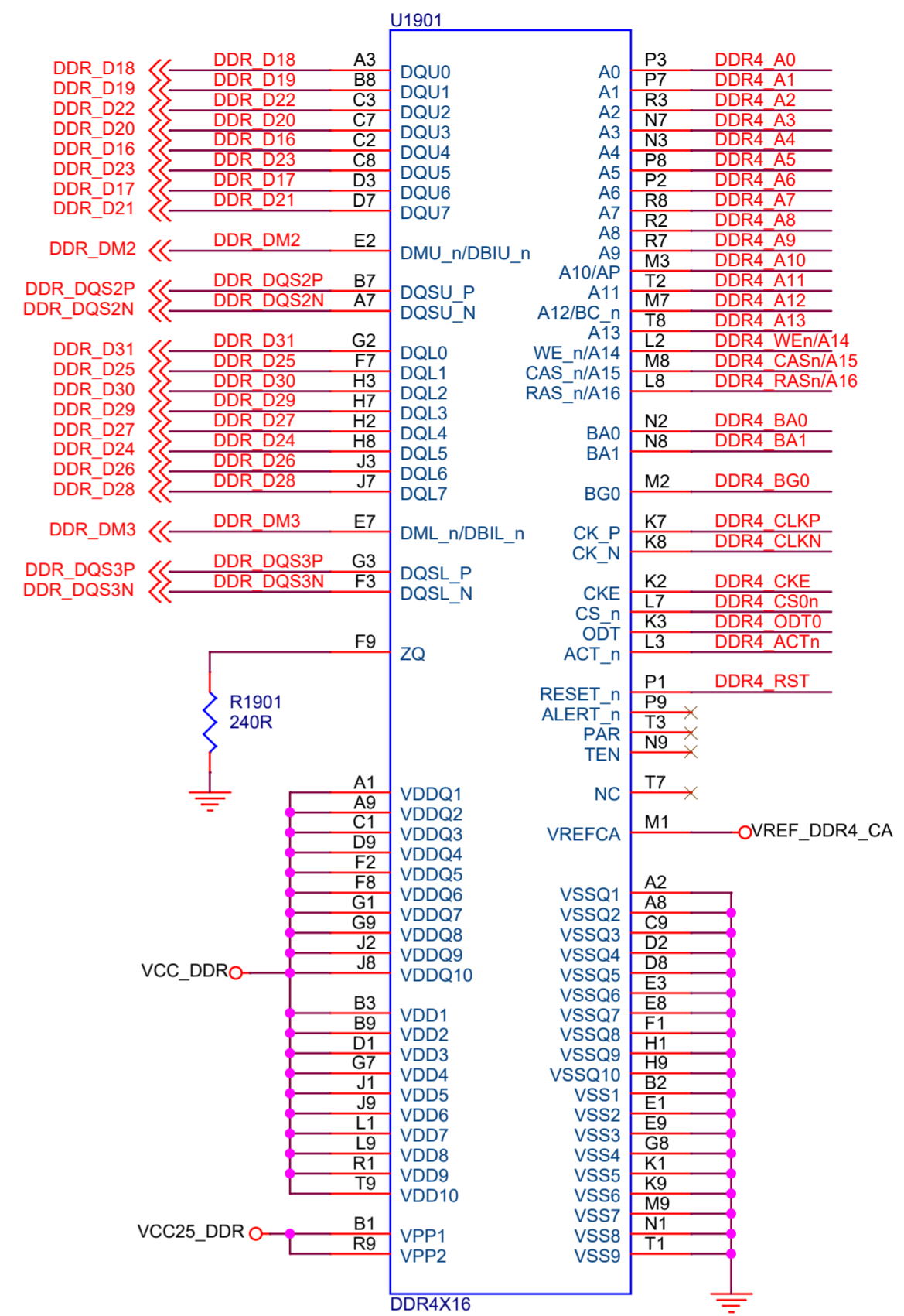
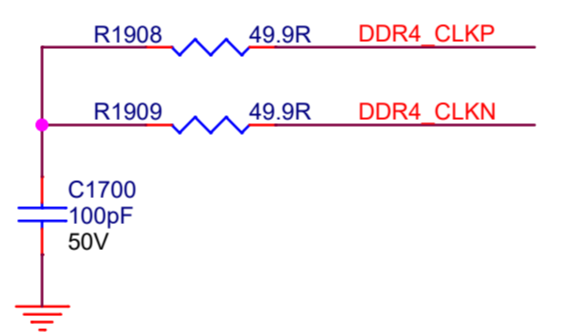
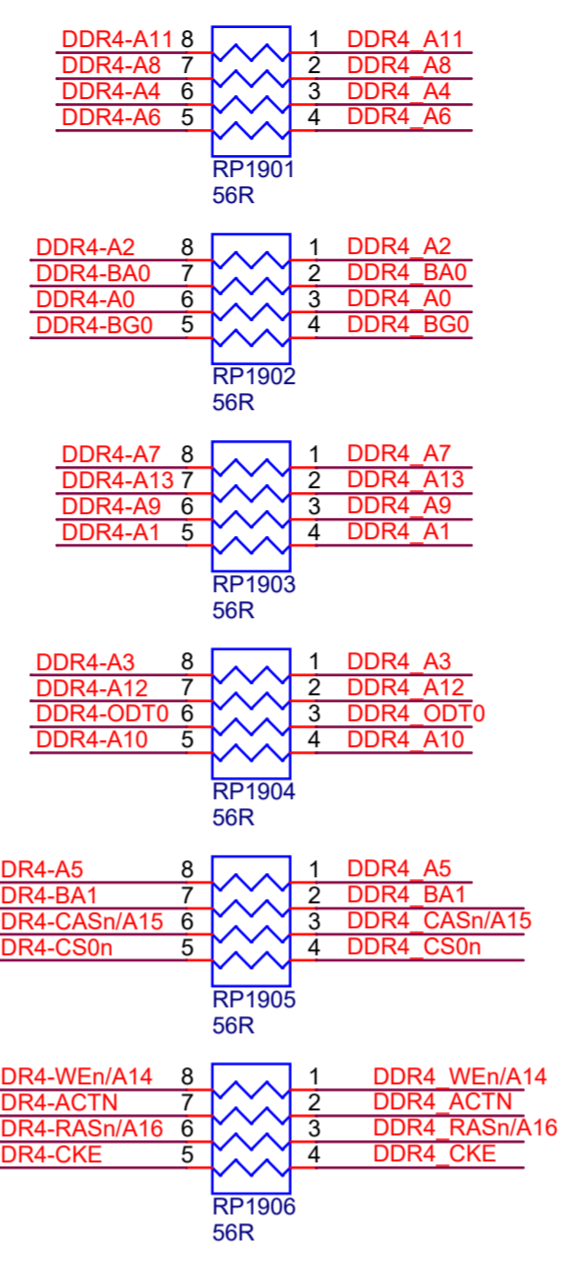
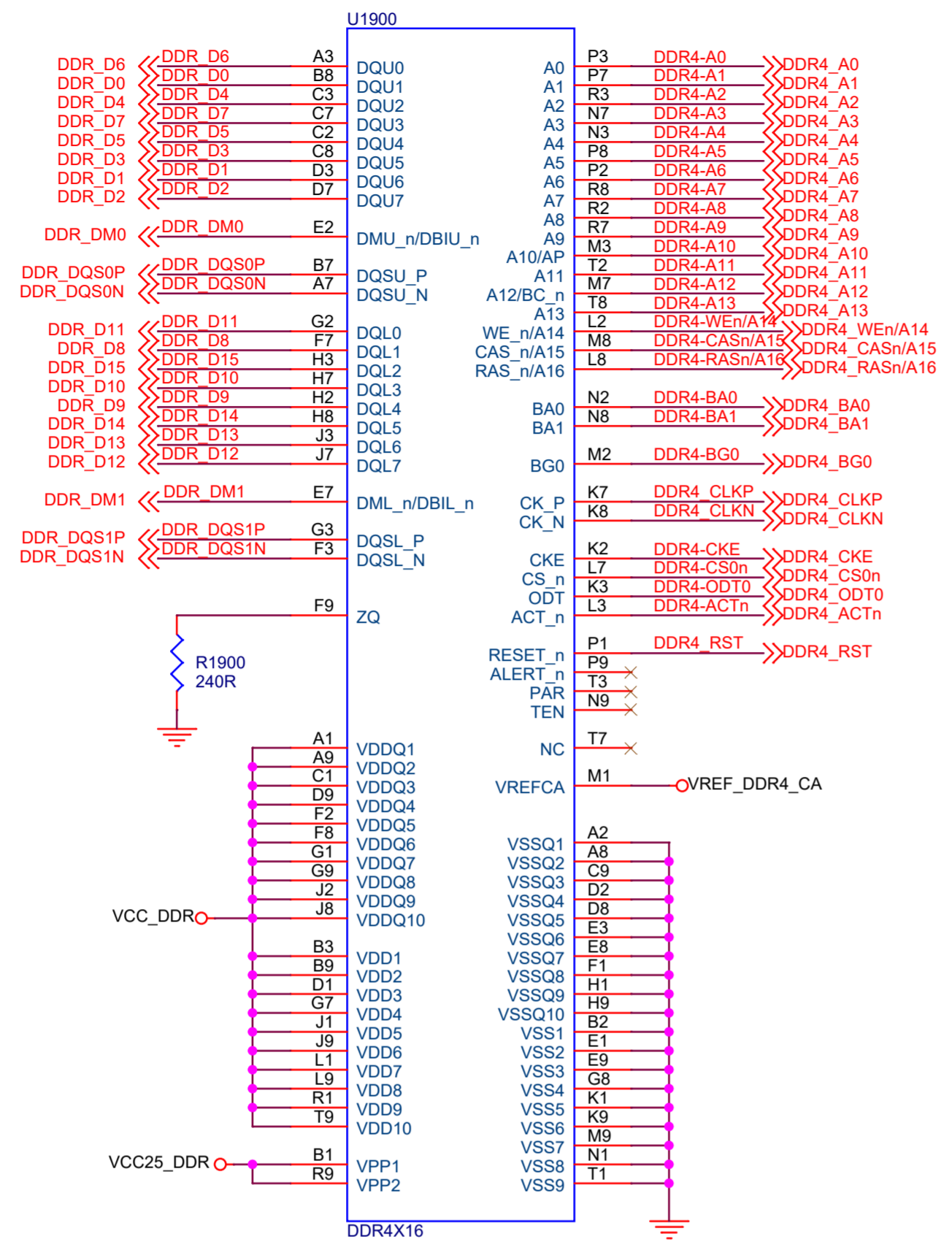

VCC_SD

SDMMC0_D2/JTAG_TCK
SDMMC0_D3/JTAG_TMS
SDMMC0_CMD

SDMMC0_CLK R2107 22R

SDMMC0_D0
SDMMC0_D1
SDMMC0_DET

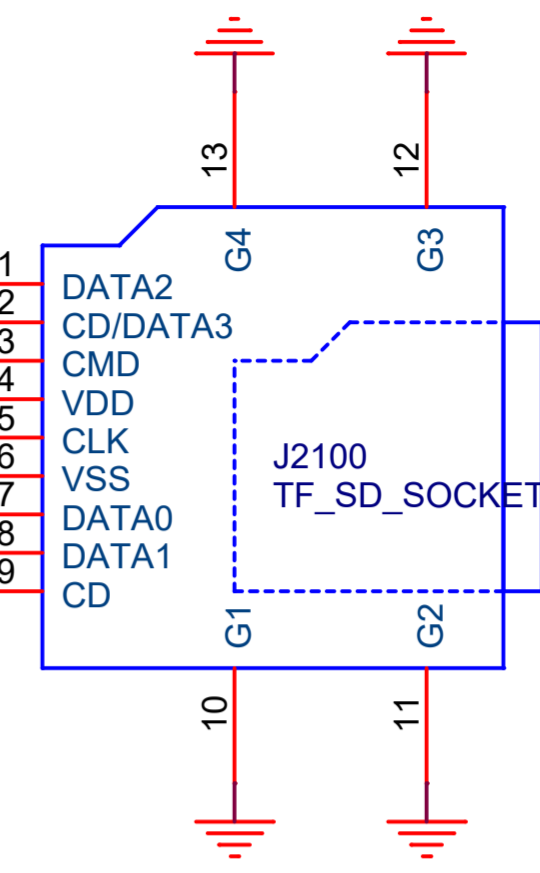
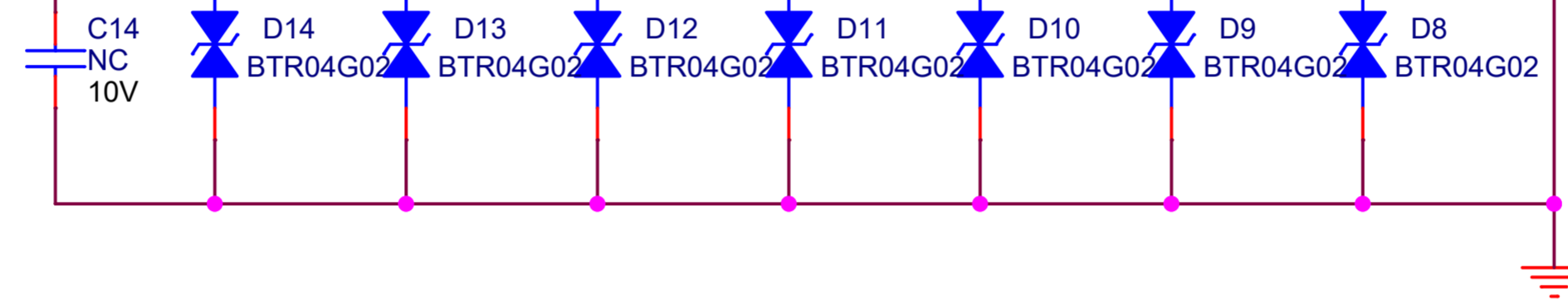
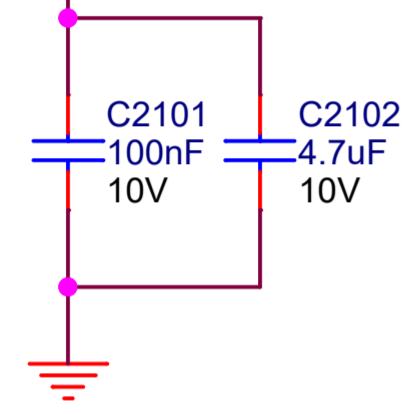

SDMMC0_D0
SDMMC0_D1
SDMMC0_D2/JTAG_TCK
SDMMC0_D3/JTAG_TMS
SDMMC0_CMD
SDMMC0_CLK
SDMMC0_DET
SDMMC0_PWREN

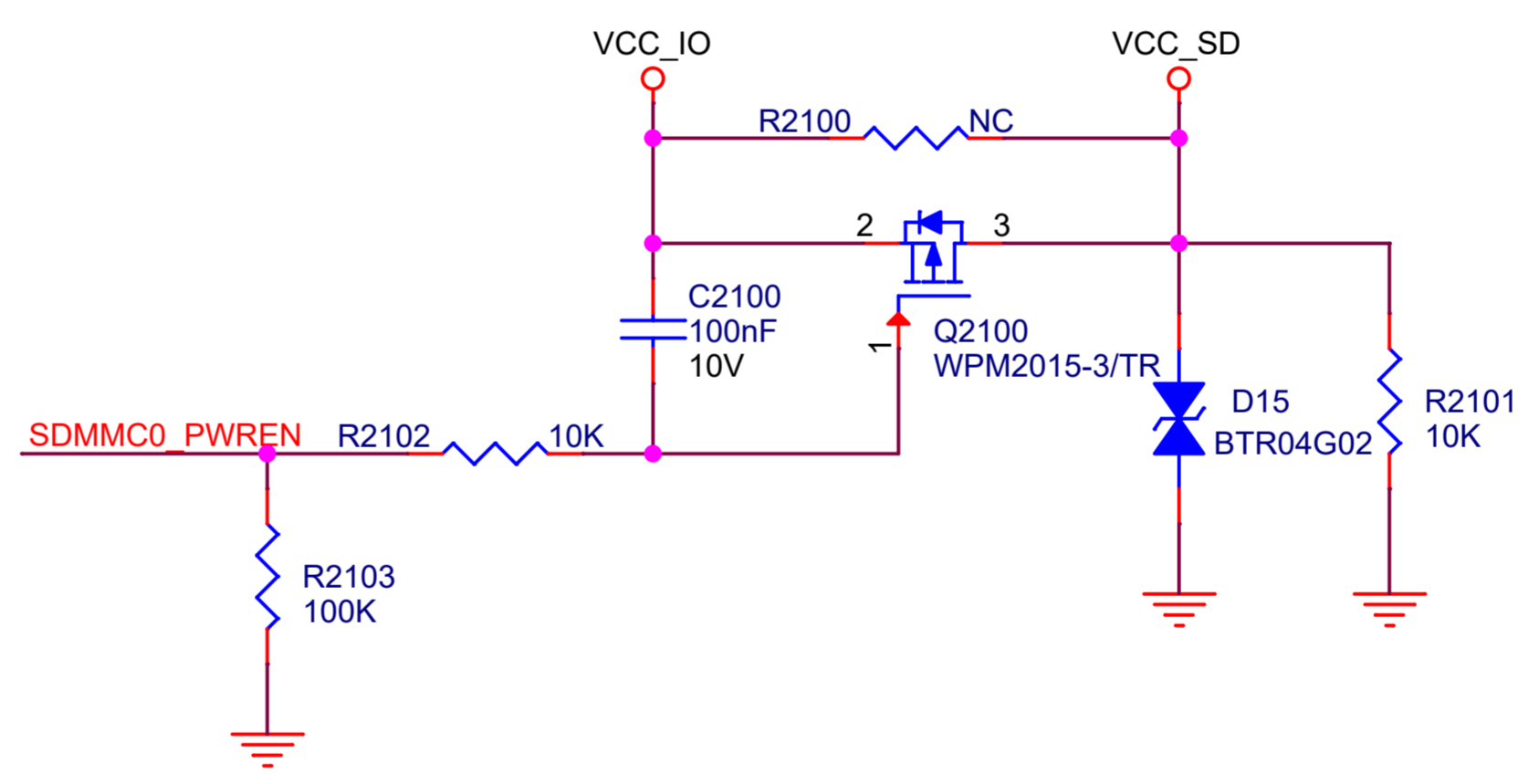

Size	Title: Radxa ROCK Pi E	REV
A4	Page Name: 15.TF/SD Card	3.0
Date: Monday, May 20, 2024	Sheet 15 of 21	

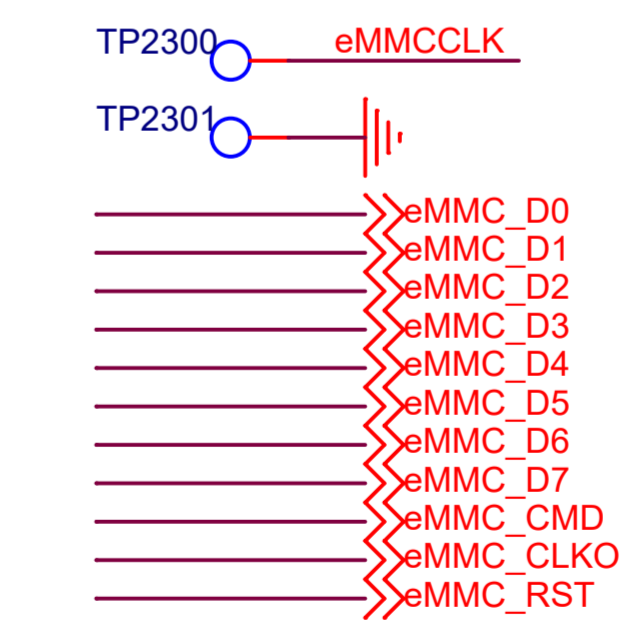
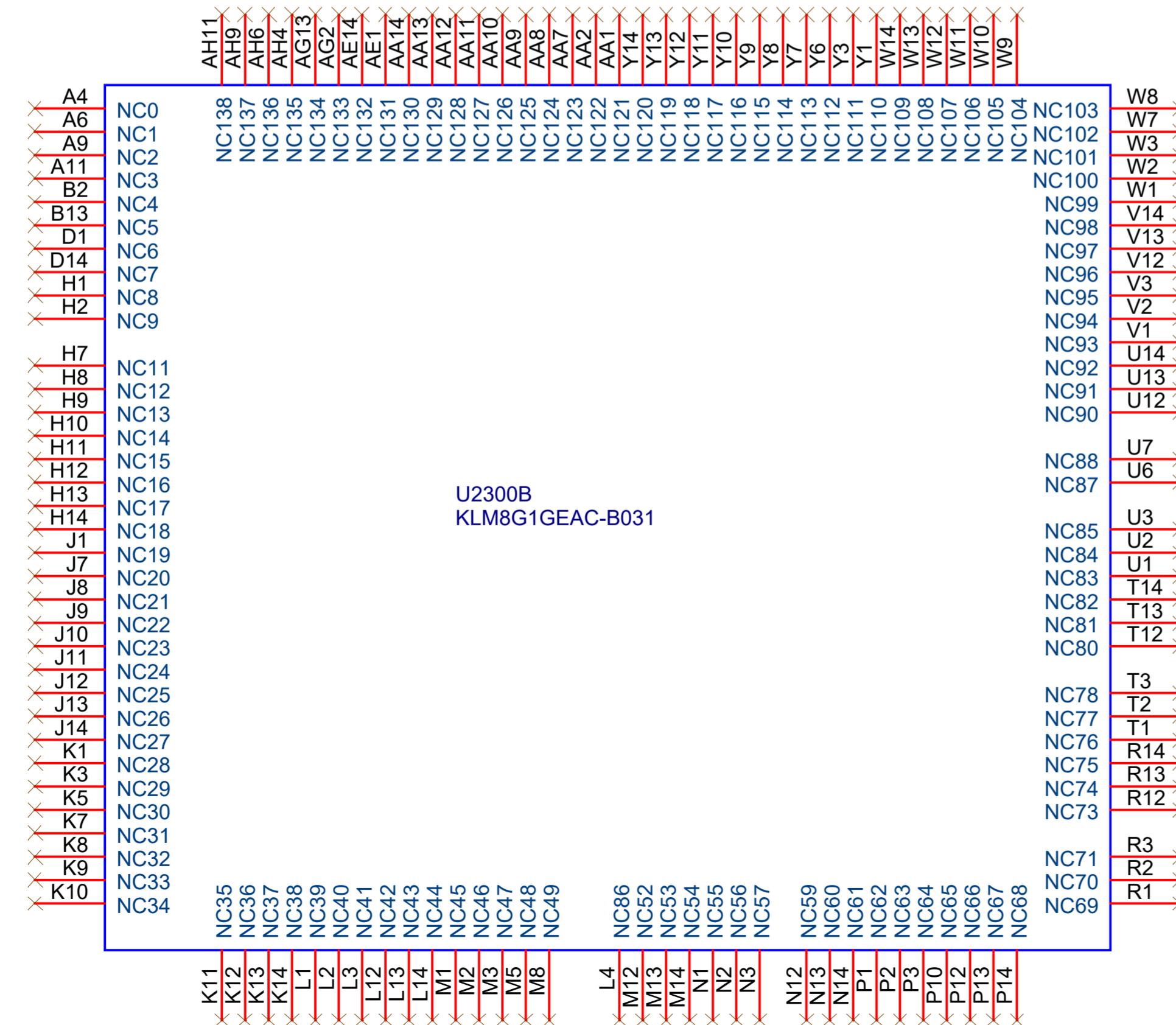
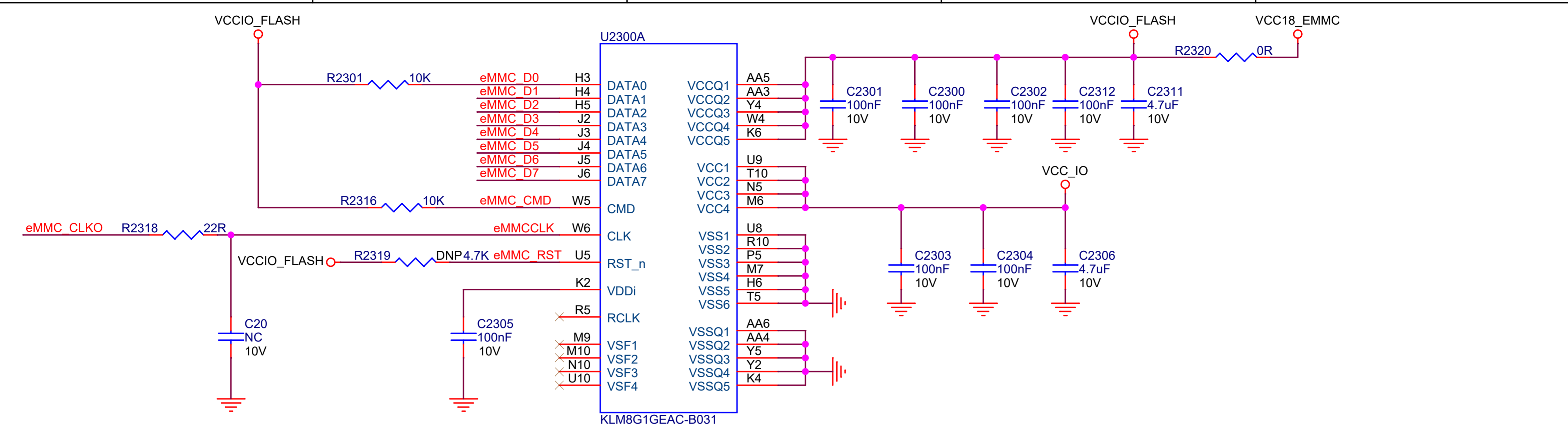



Size	Title: Radxa ROCK Pi E	REV
A4	Page Name: 16.Flash-eMMC	3.0
Date:	Monday, May 20, 2024	Sheet 16 of 21

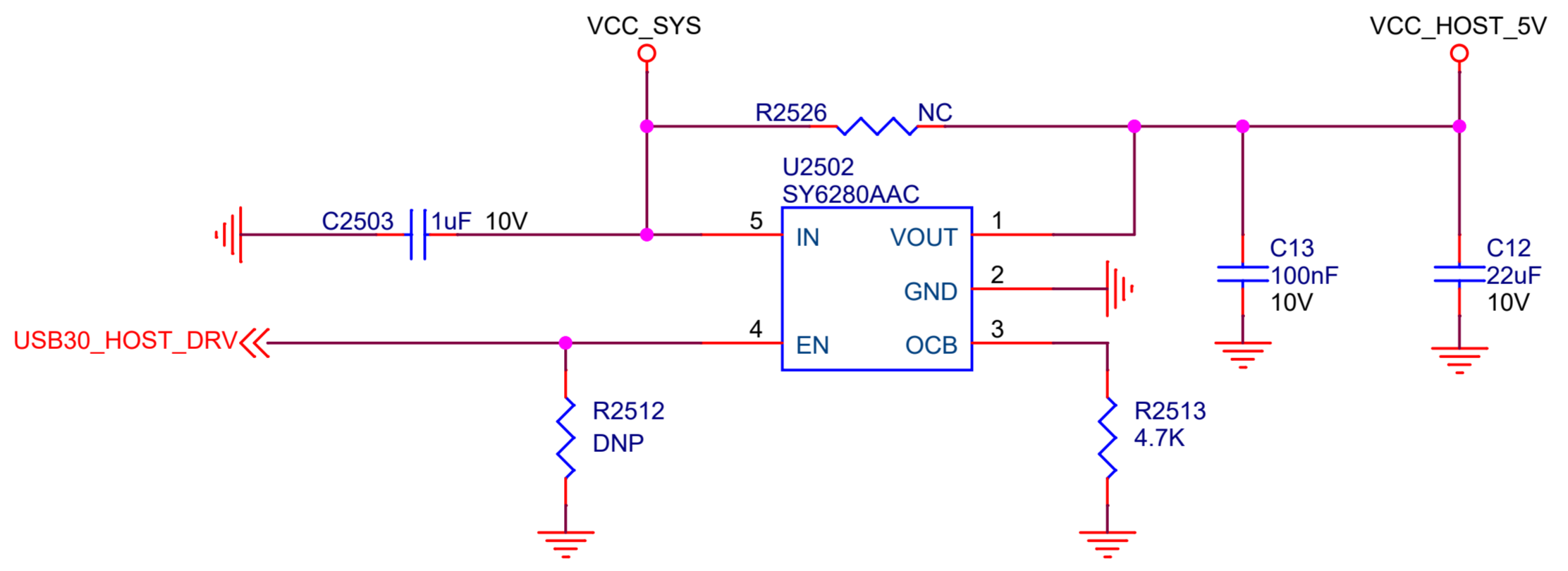
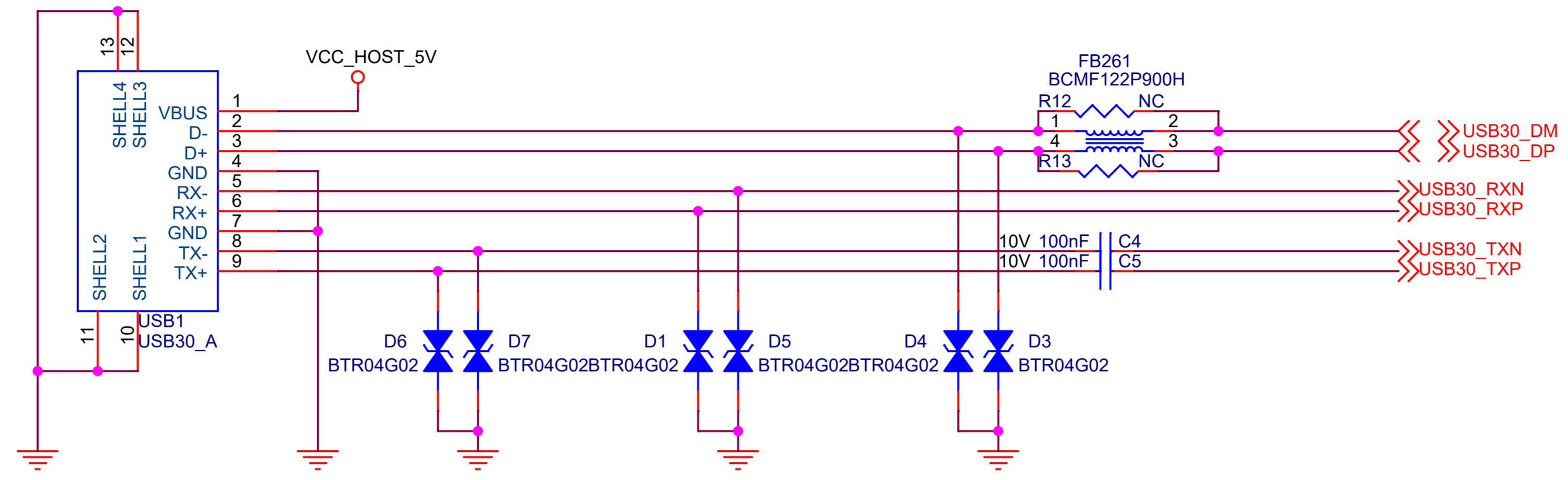

Size	Title: Radxa ROCK Pi E	REV
A4	Page Name: 17.USB Port	3.0
Date: Monday, May 20, 2024	Sheet 17 of 21	

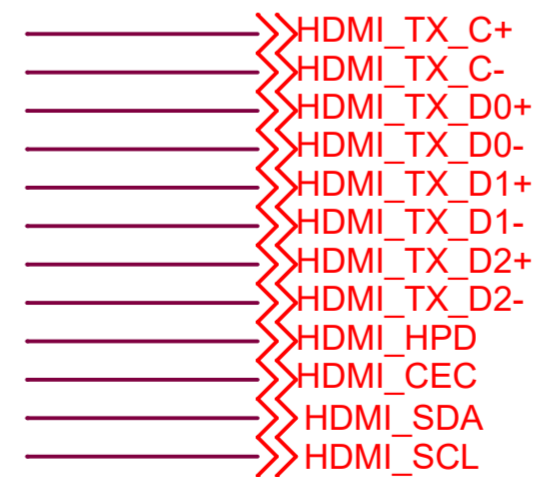
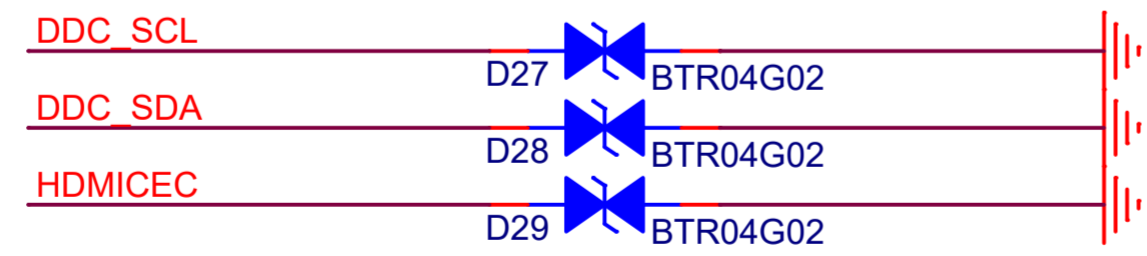
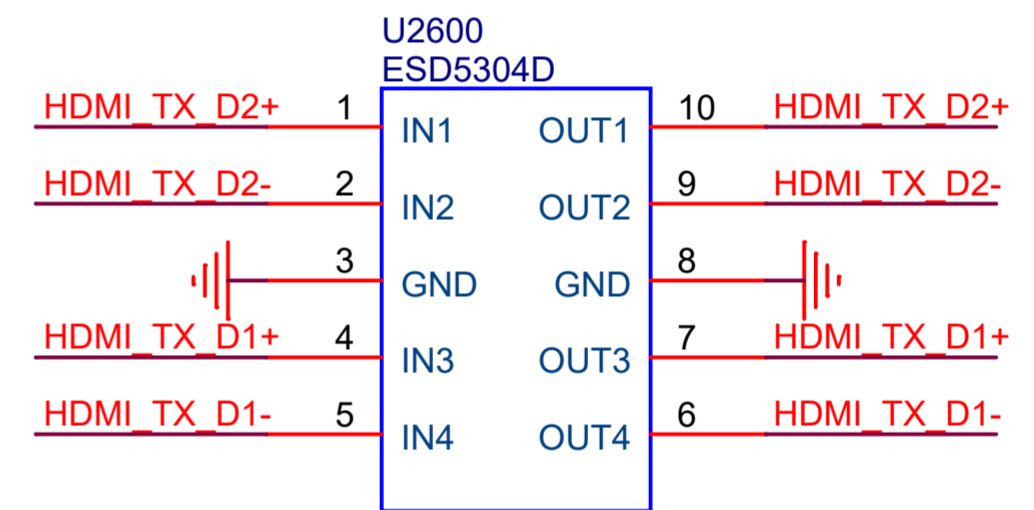
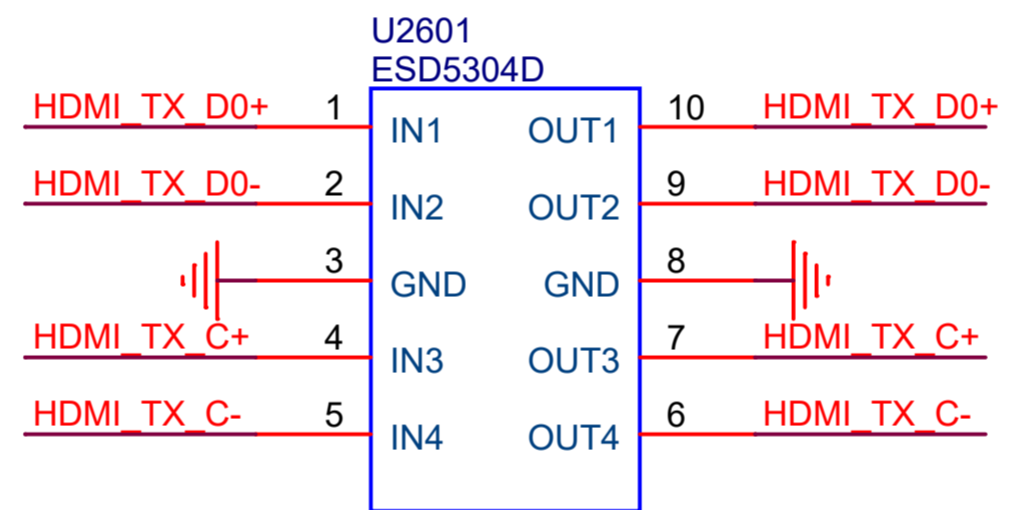
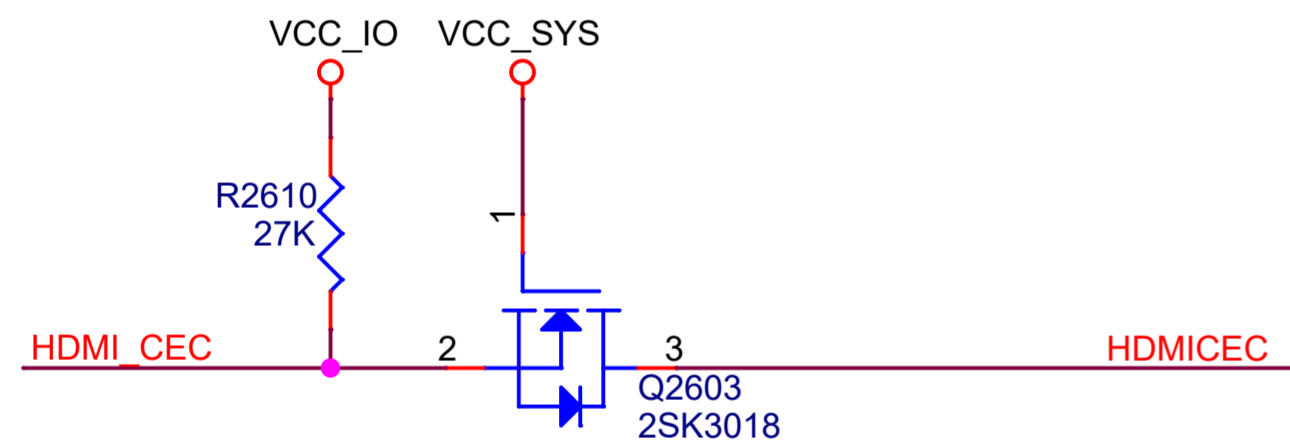
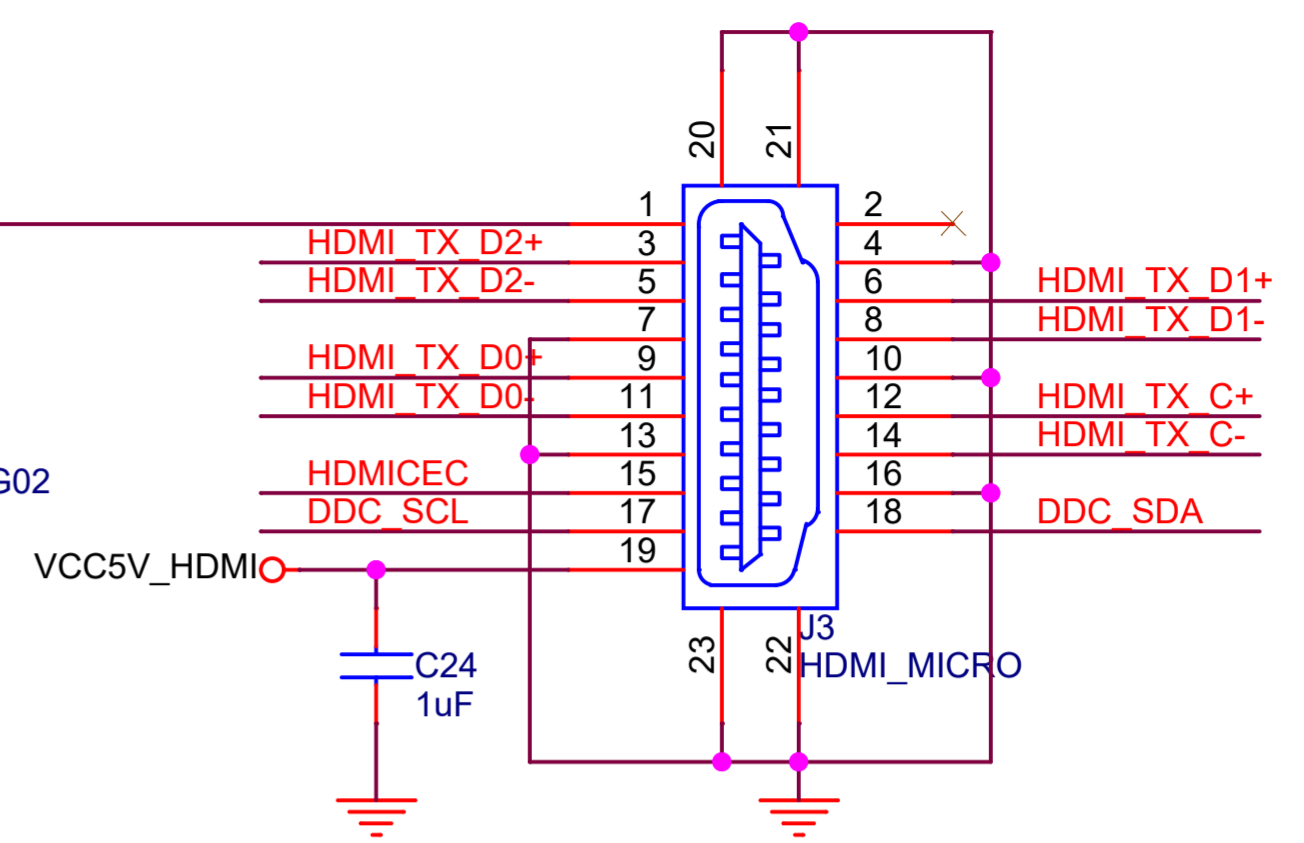
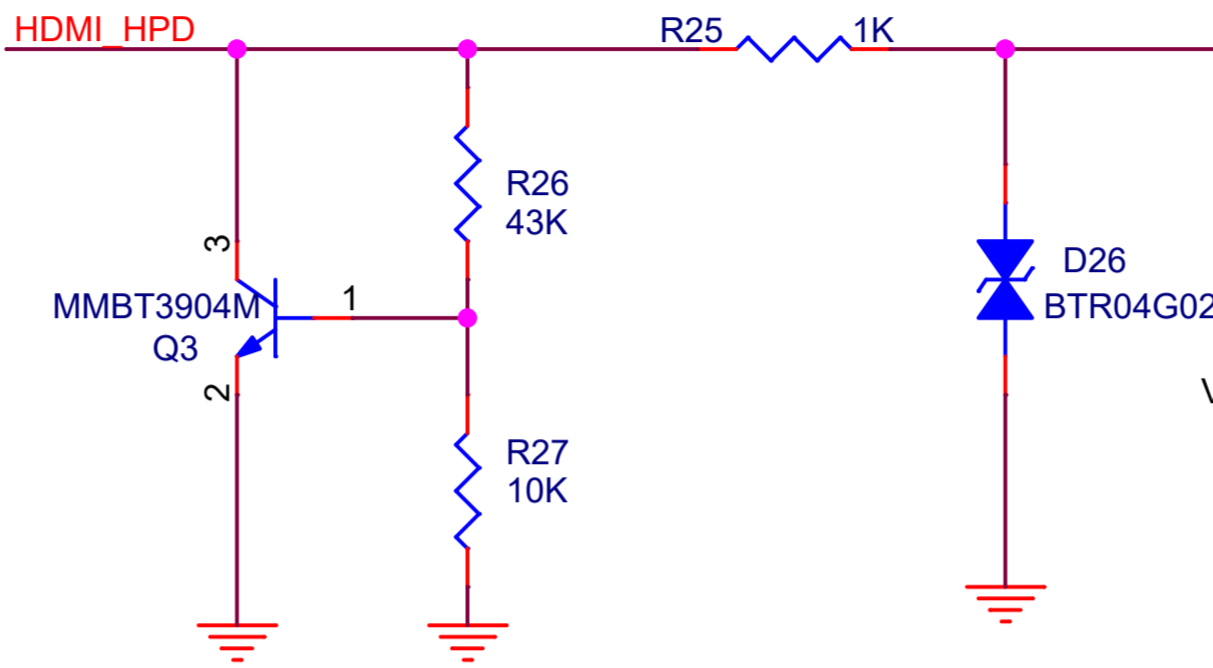
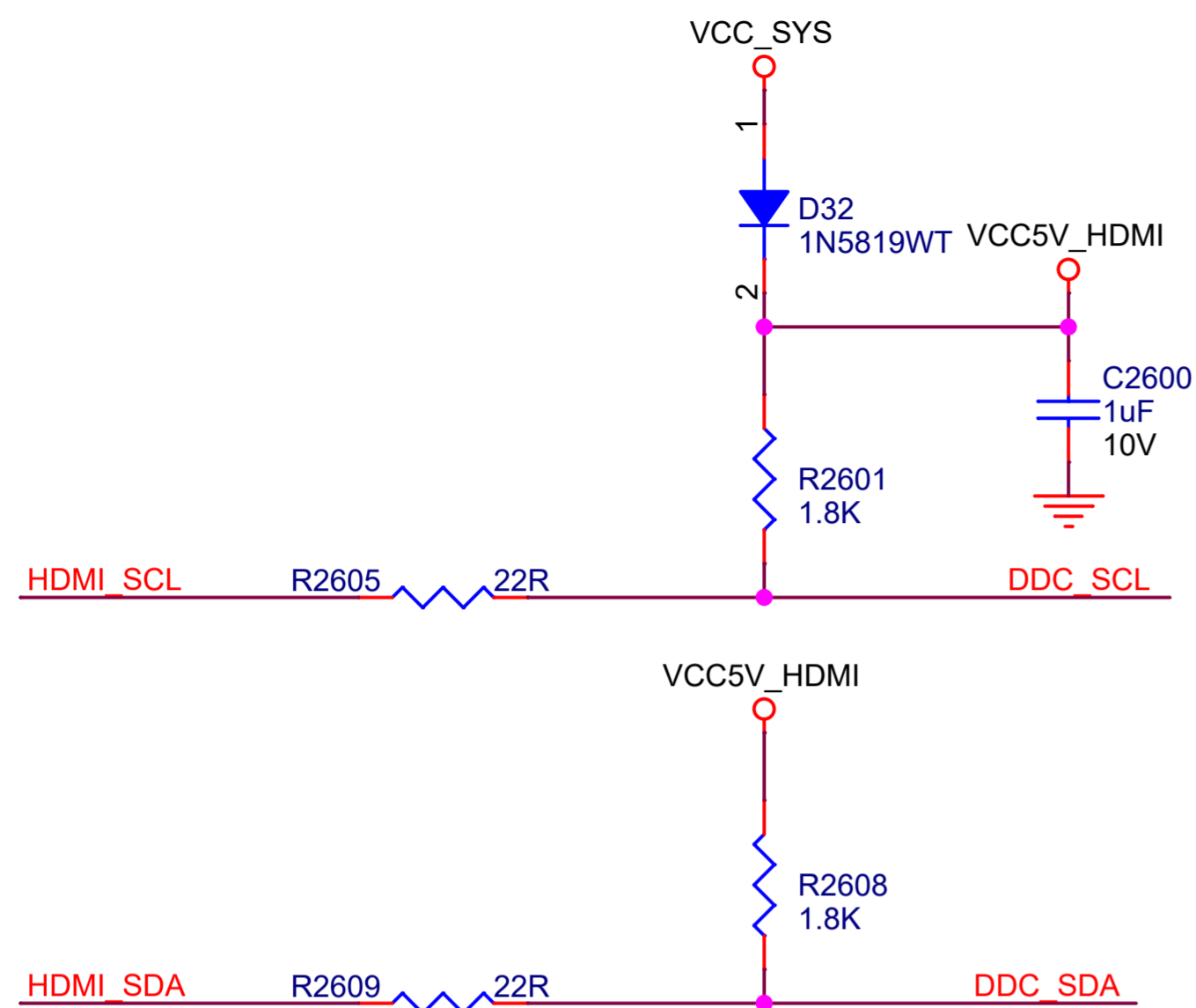

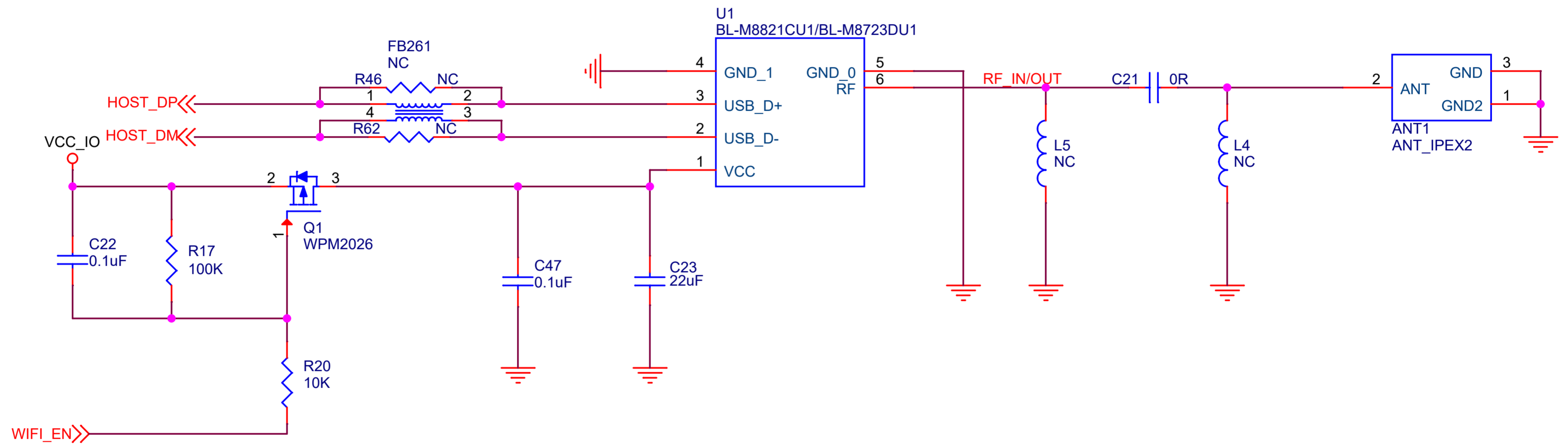

radxa

Size	Title: Radxa ROCK Pi E	REV
A4	Page Name: 19.WIFI+BT	3.0
Date: Monday, May 20, 2024	Sheet 19 of 21	

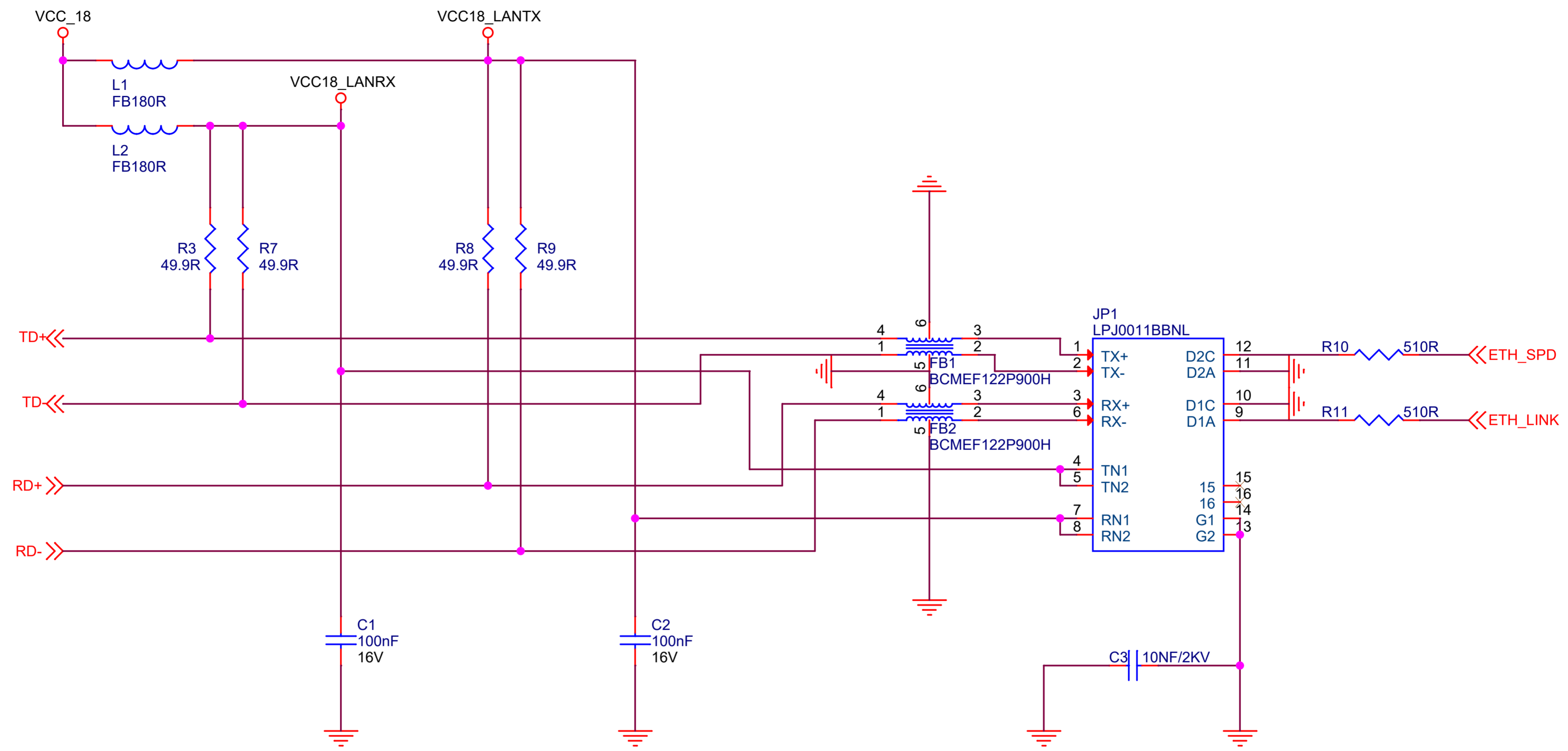

Size	Title: Radxa ROCK Pi E	REV
A4	Page Name: 20.10/100M-Embed PHY	3.0
Date: Monday, May 20, 2024	Sheet 20 of 21	

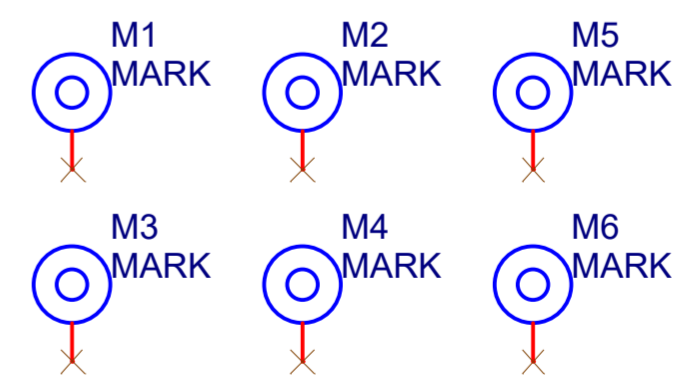
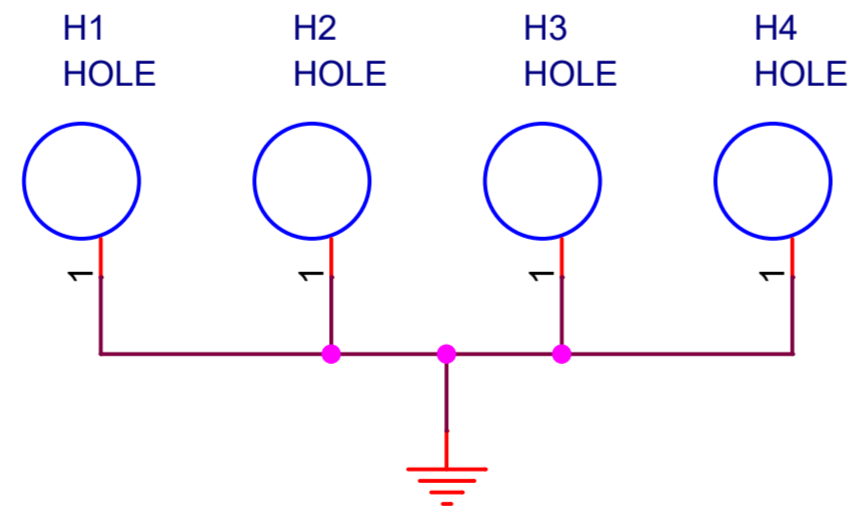
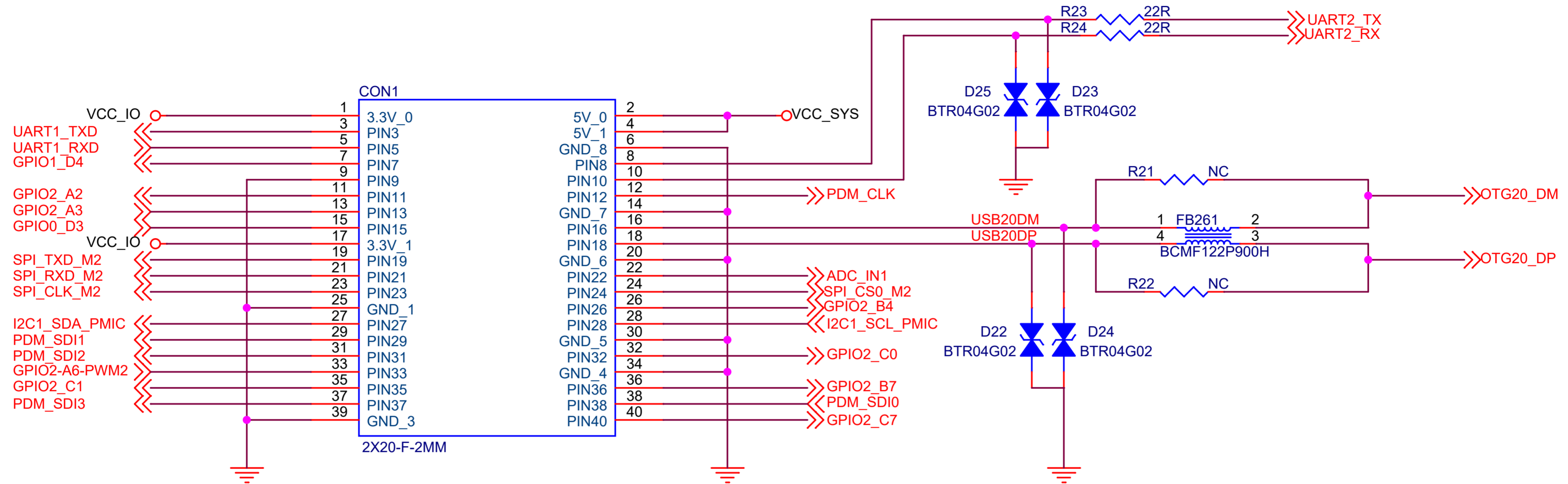

Size	Title: Radxa ROCK Pi E	REV
A4	Page Name: 21.CON	3.0
Date: Monday, May 20, 2024	Sheet 21 of 21	