

TF Card

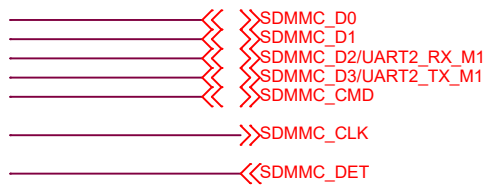

VCC_IO	SDMMC_D2/UART2_RX_M1	R9103	1	22R	2	5%	R0201
	SDMMC_D3/UART2_TX_M1	R9104	1	22R	2	5%	R0201
	SDMMC_CMD	R9105	1	22R	2	5%	R0201
	SDMMC_CLK						
	SDMMC_D0	R9106	1	22R	2	5%	R0201
	SDMMC_D1	R9107	1	22R	2	5%	R0201
	SDMMC_DET	R9102	1	22R	2	5%	R0201

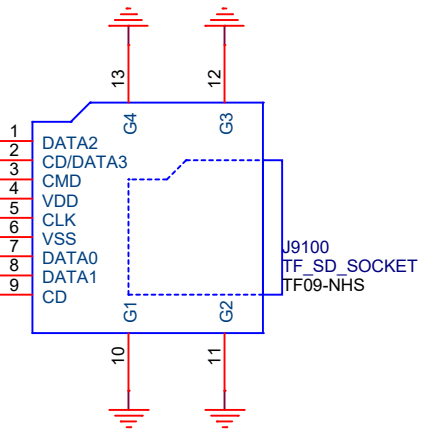
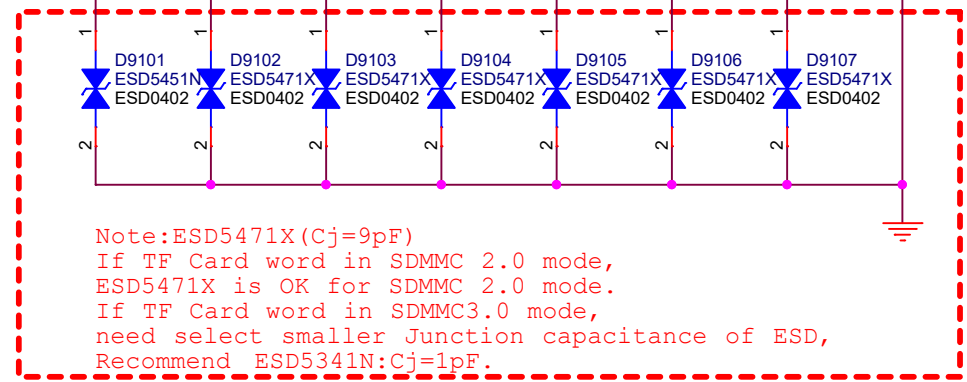
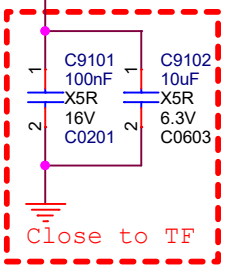

SPI Flash

Remind: Refer to the latest AVL for parts selection.

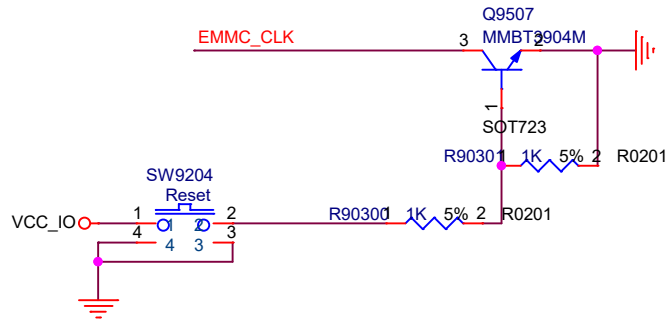
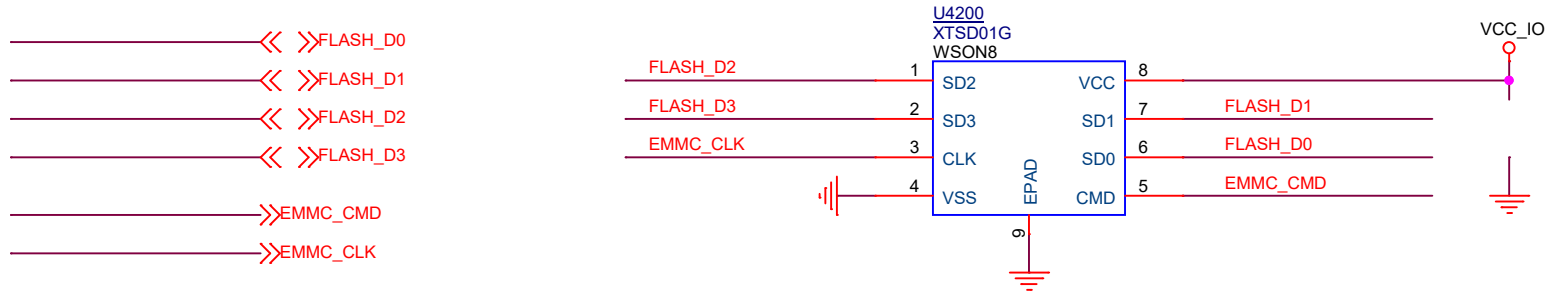

USB OTG

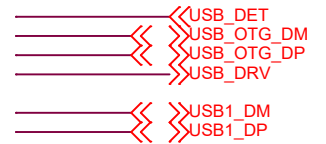

USB-HUB_PORTBA
USB2500
USB_L

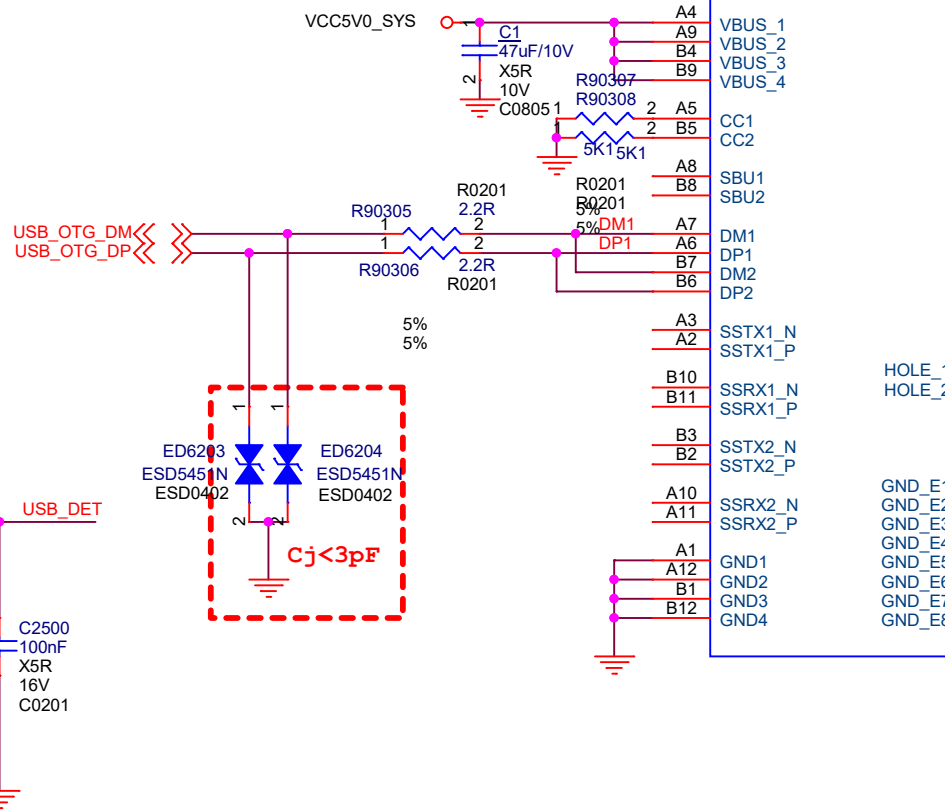
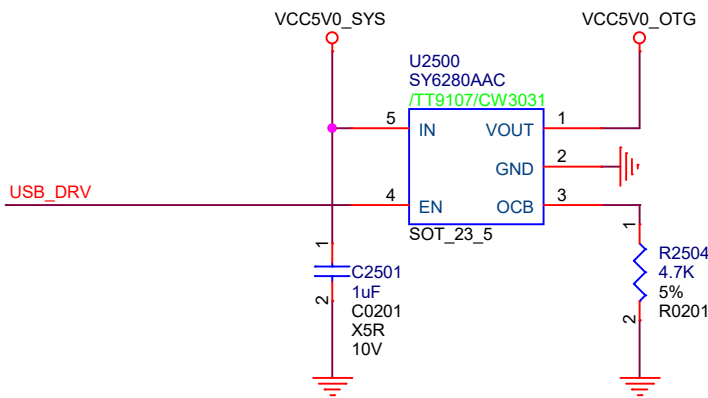
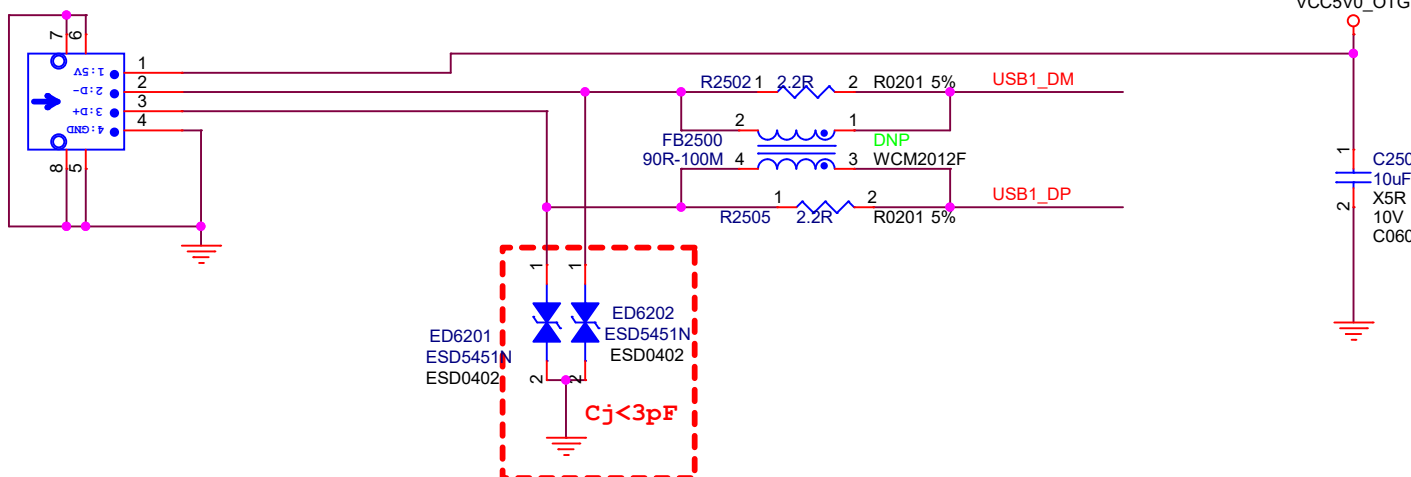

J2600
USB_TYPEC_115H0
TYPEC-16PIN-SMD1

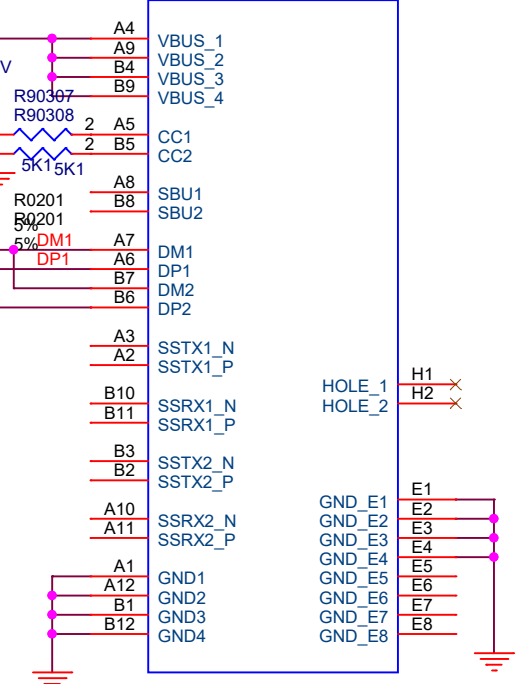

VDD_ARM

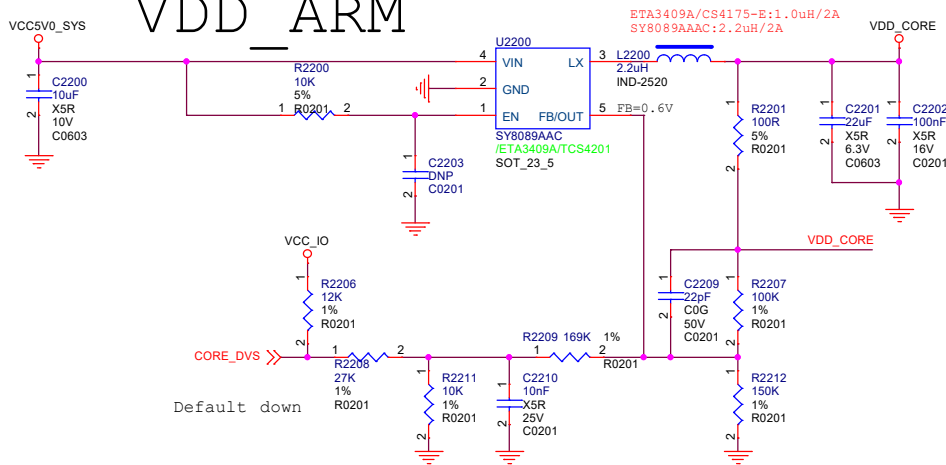

$$V = V_{max} - (V_{max} - V_{min}) * Duty$$
 Default 1.015V
 0.827-1.34V

VDD_LOG

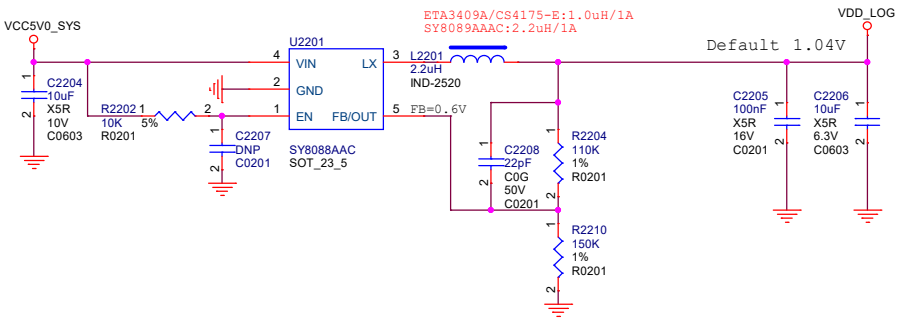

VCC_DDR

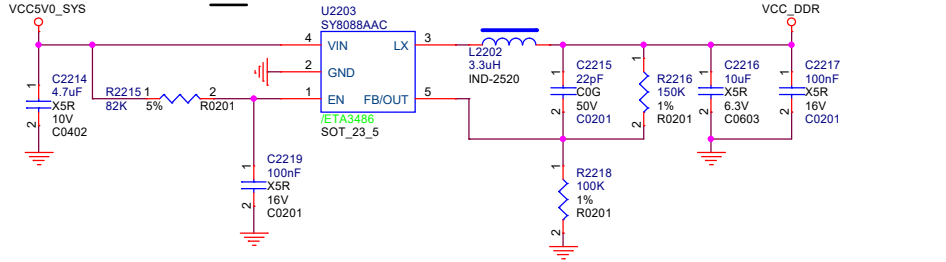

RK3308 Part-H

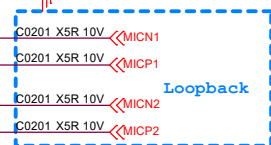
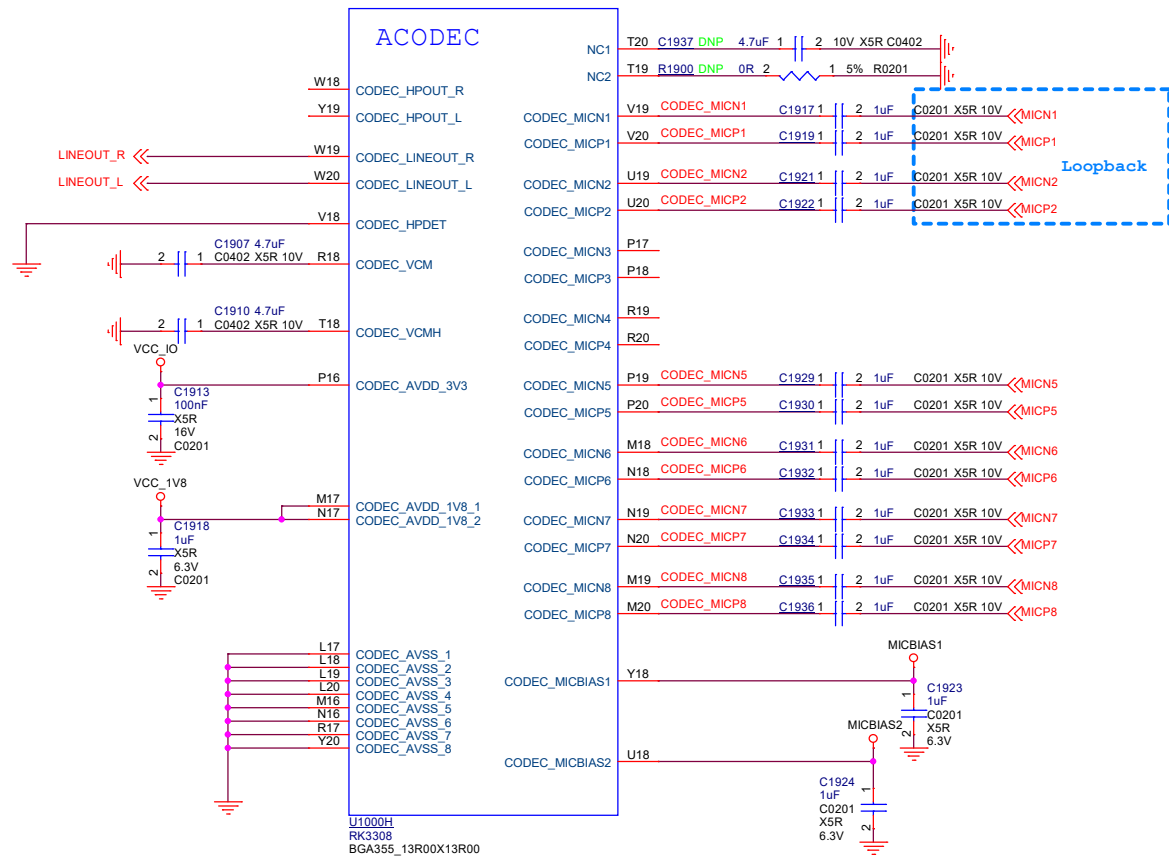

Application scene	MIC IN Channel	Loopback Channel
6MIC IN+ 2Speaker OUT	MIC3~MIC8	MIC1~MIC2
6MIC IN+ 1Speaker OUT	MIC3~MIC8	
5MIC IN+ 2Speaker OUT	MIC4~MIC8	
5MIC IN+ 1Speaker OUT	MIC4~MIC8	
4MIC IN+ 2Speaker OUT	MIC5~MIC8	
4MIC IN+ 1Speaker OUT	MIC5~MIC8	
3MIC IN+ 1Speaker OUT	MIC6~MIC8	
2MIC IN+ 1Speaker OUT	MIC7~MIC8	

ACODEC

U1000H
RK3308
BGA355_13R00X13R00

RK3308 Part-B

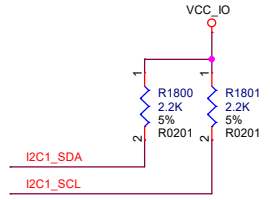
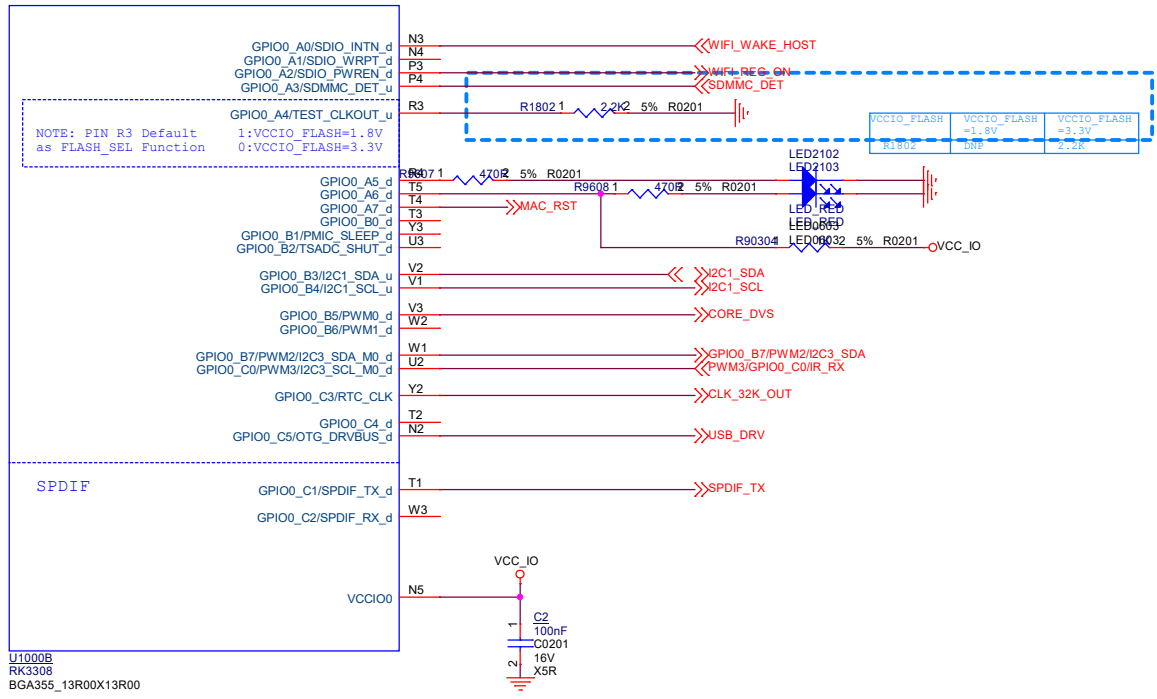

RK3308 Part-D

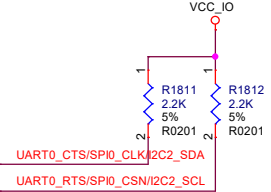
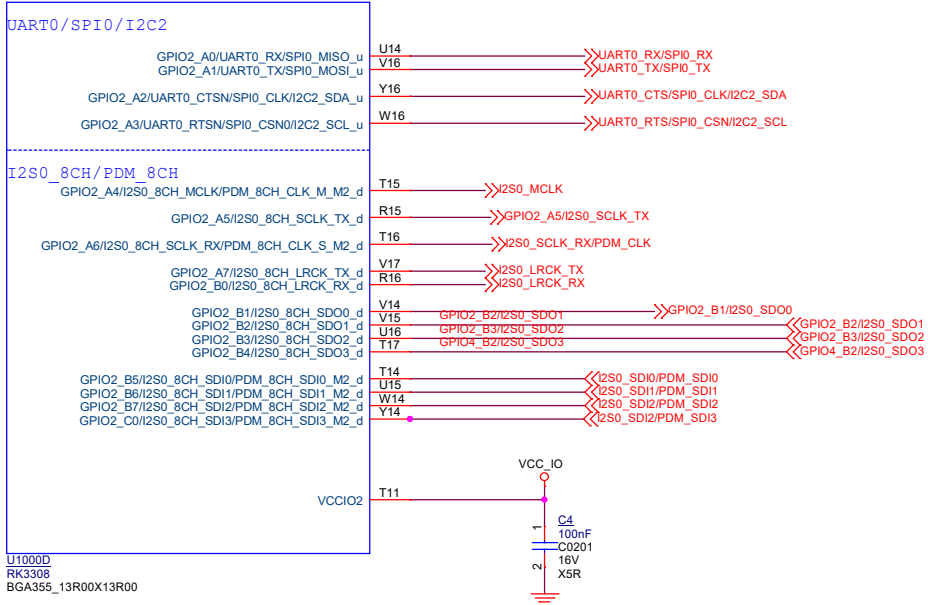

RK3308 Part-F

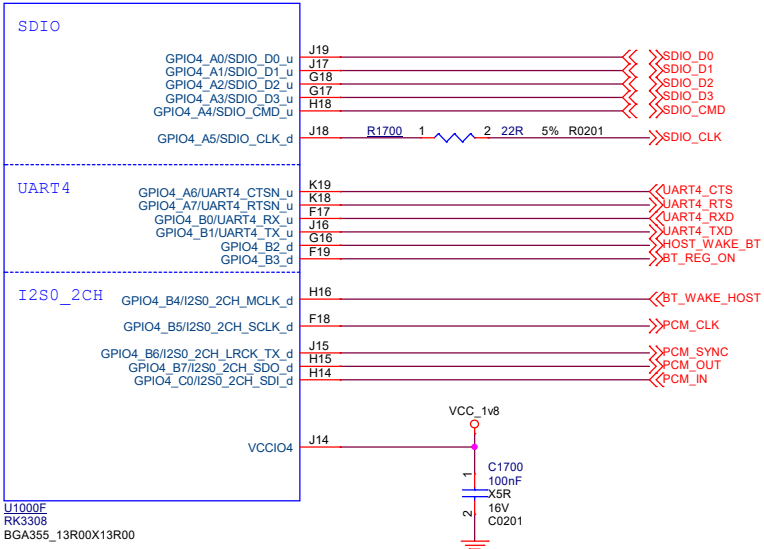

RK3308 Part-G

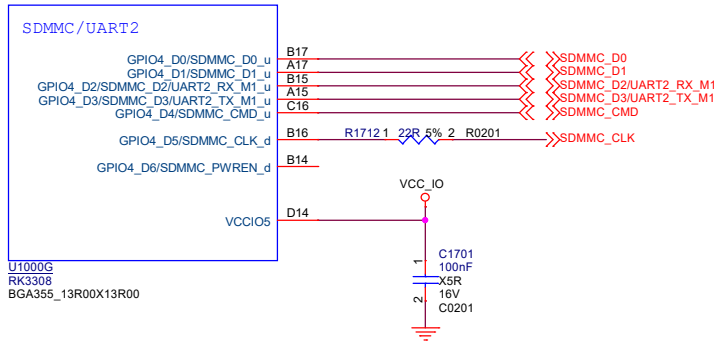

RK3308 Part-C

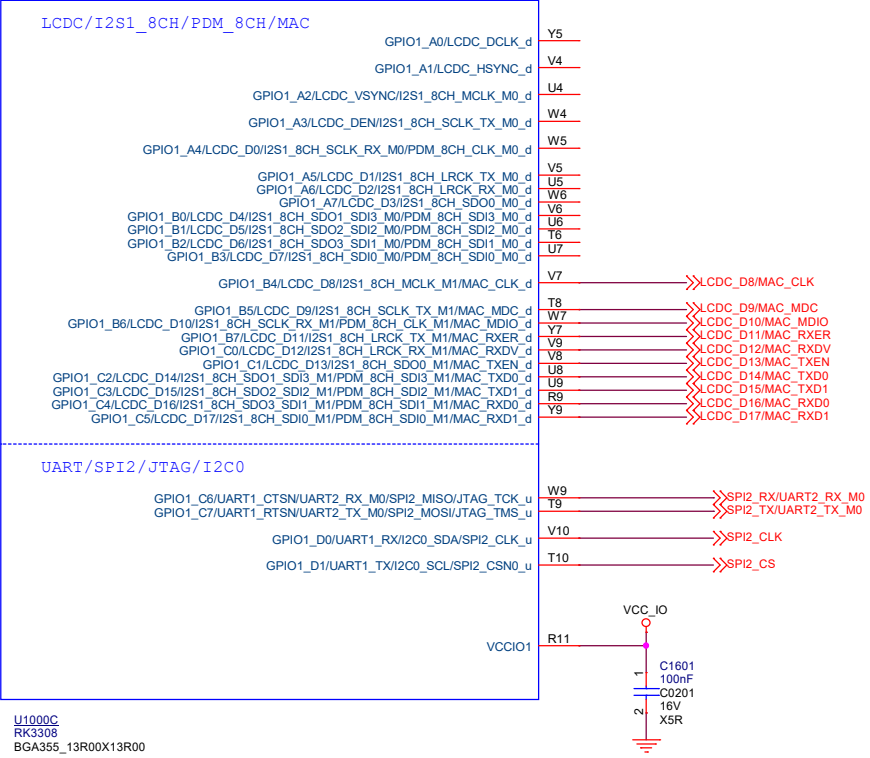

U1000C
RK3308
BGA355_13R00X13R00

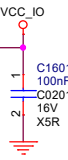

RK3308 Part-J

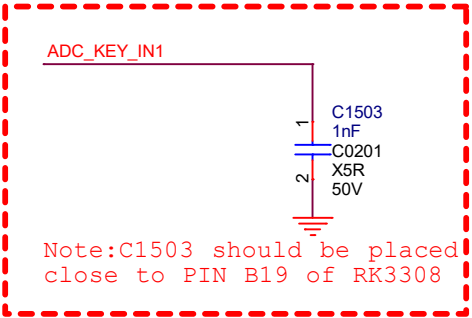
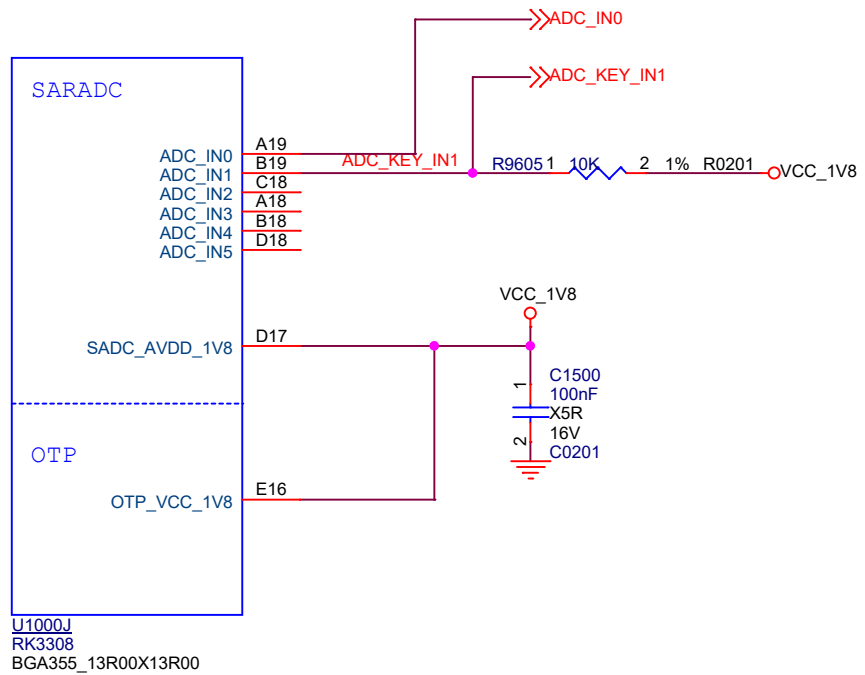

Note: C1503 should be placed close to PIN B19 of RK3308

RK3308 Part-I

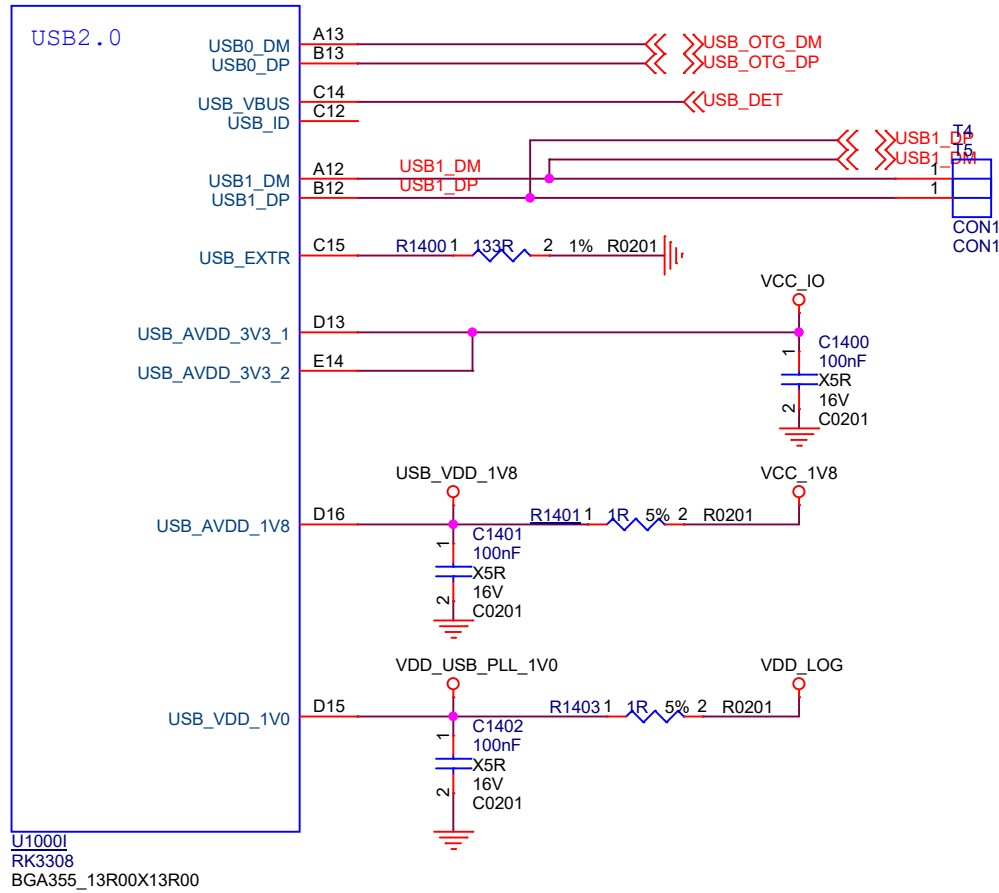

RK3308 Part-E

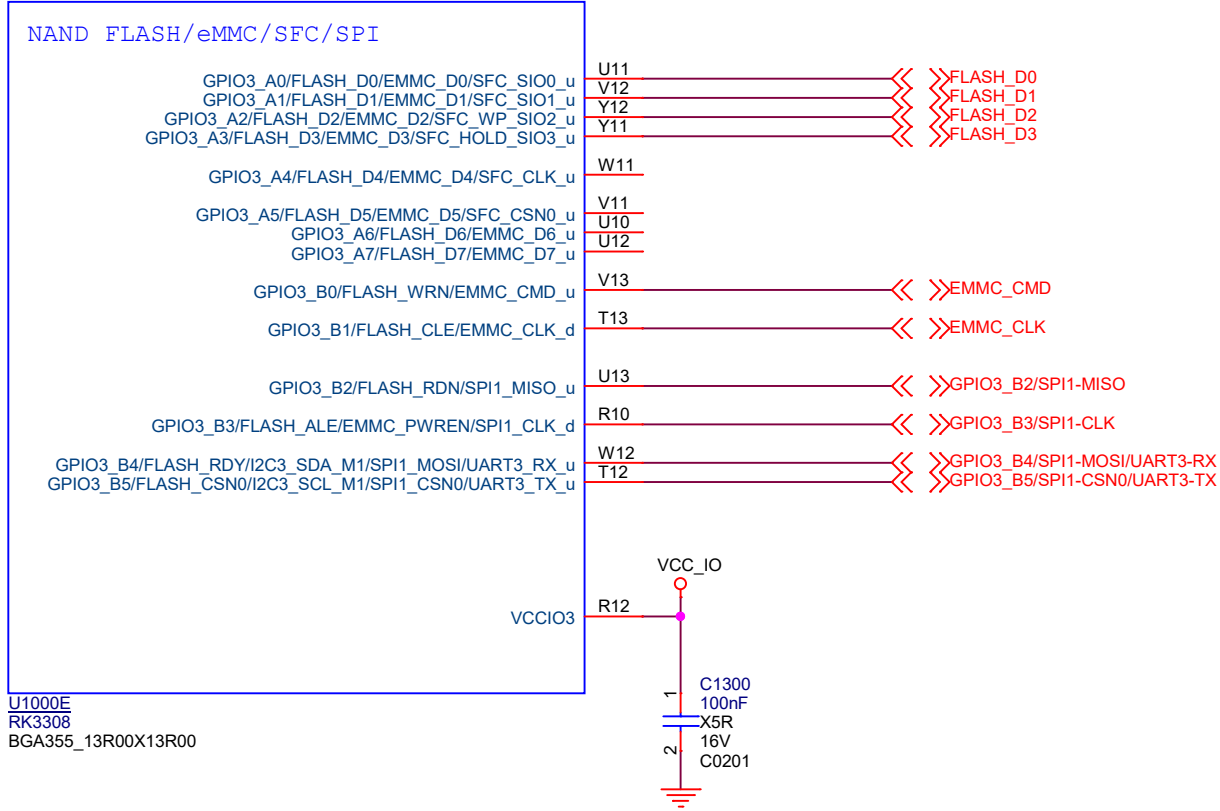

RK3308 Part-K

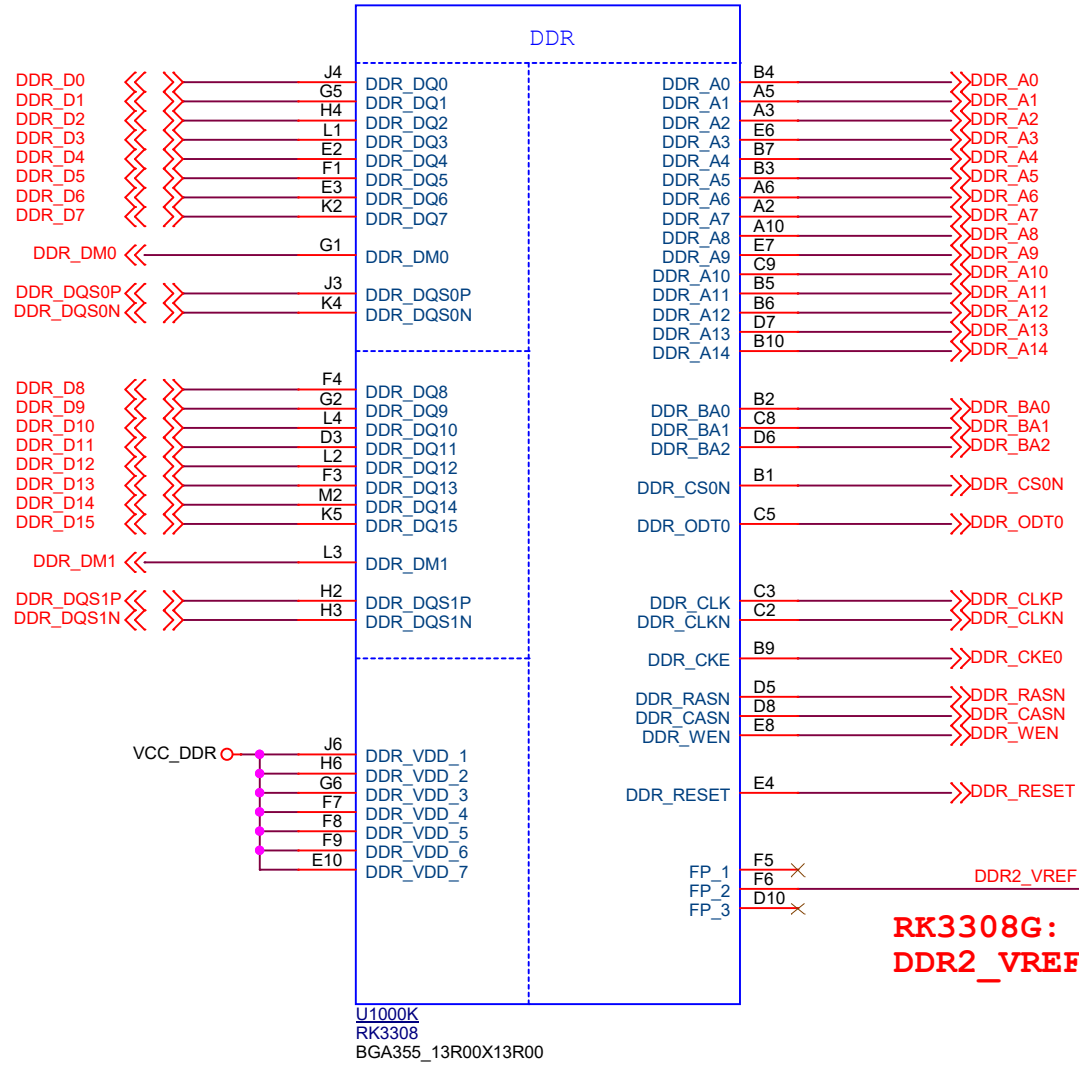

**RK3308G:
DDR2_VREF**

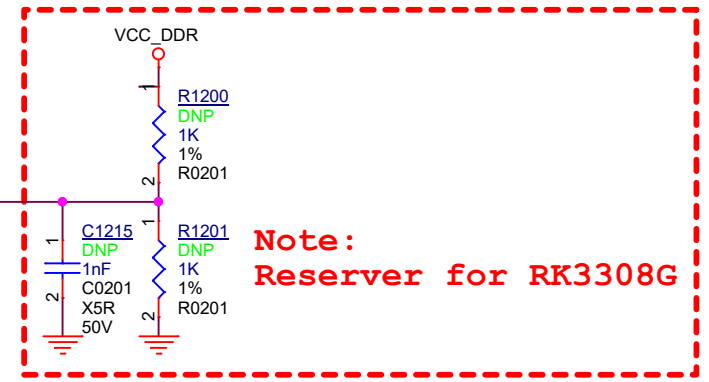

Power Filter

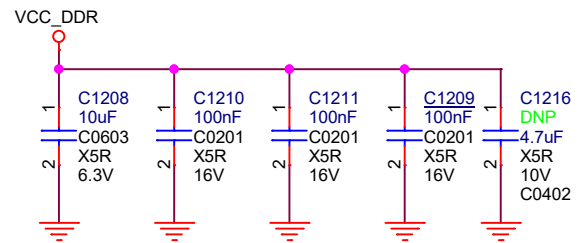

Note: All the Power filter capacitors should be placed close to the power pins of RK3308

RK3308 Part-A

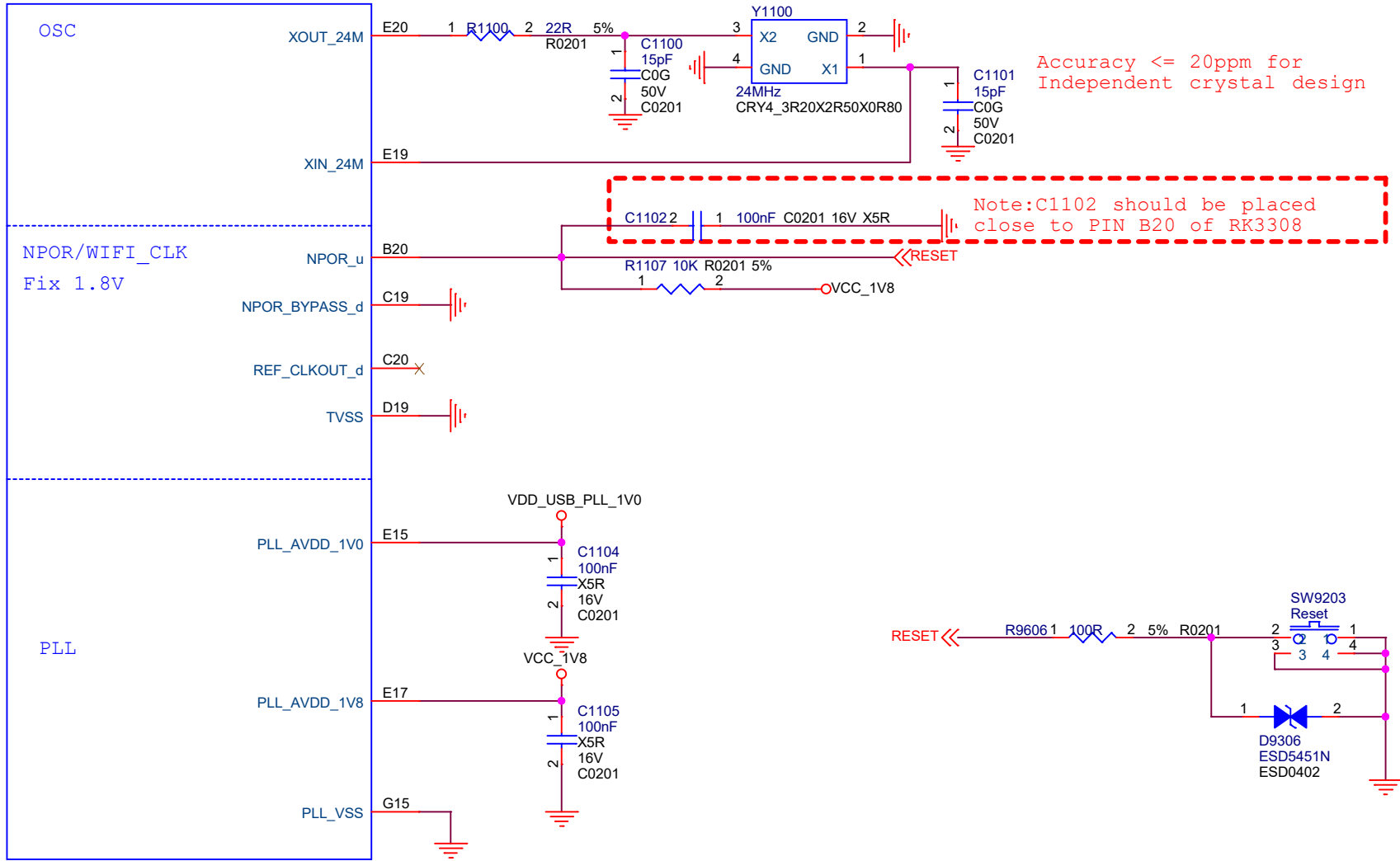

Accuracy <= 20ppm for Independent crystal design

Note: C1102 should be placed close to PIN B20 of RK3308

U1000A
RK3308
BGA355_13R00X13R00

RK3308 Part-L

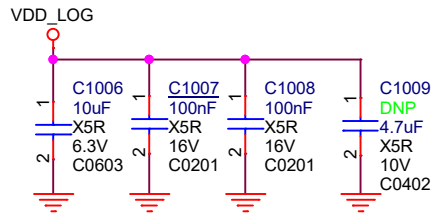
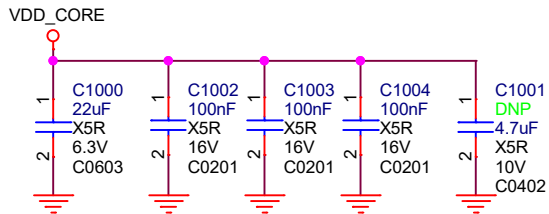
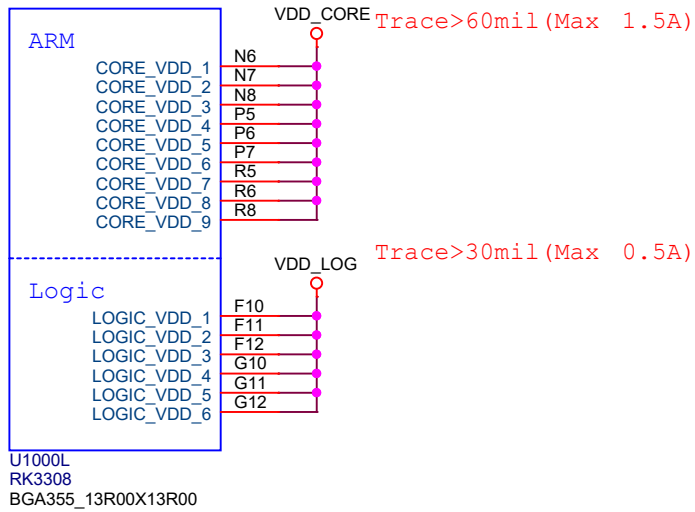

Note: All the Power filter capacitors should be placed close to the power pins of RK3308

RK3308 Part-N

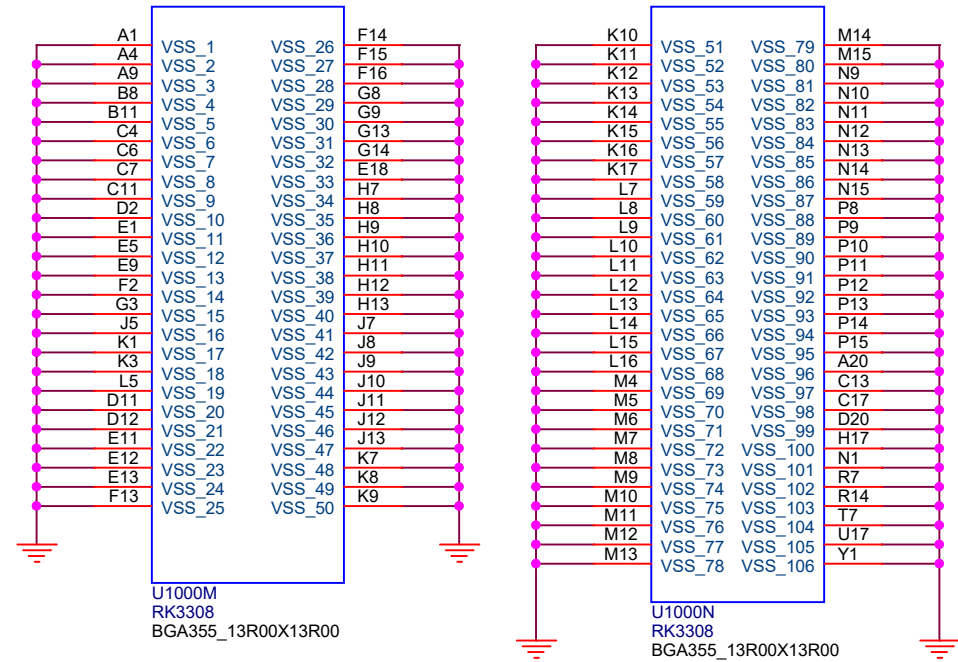

10/100M PHY-RTL8201F

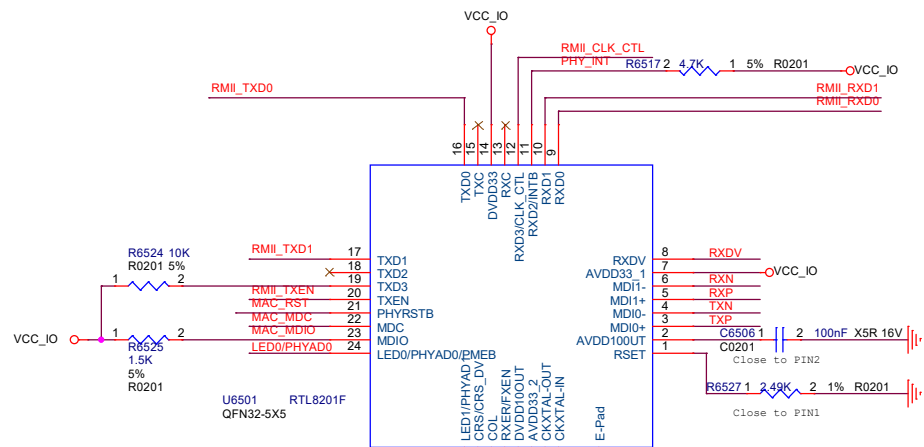
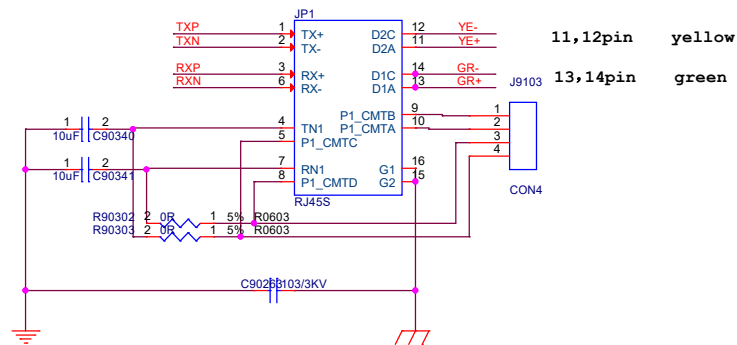
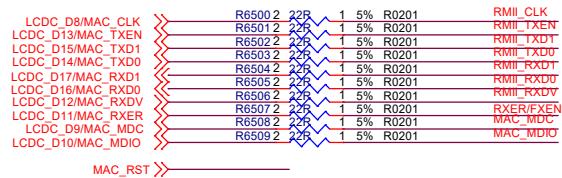

	25MHz Crystal	NO 25MHz Crystal (Default)
Option1	0R	DNP
Option2	DNP	10K
Option3	DNP	0R
Option4	Be mounted	Not be mounted
Option5	R6518=4.7K R6519=DNP	R6518=DNP R6519=4.7K

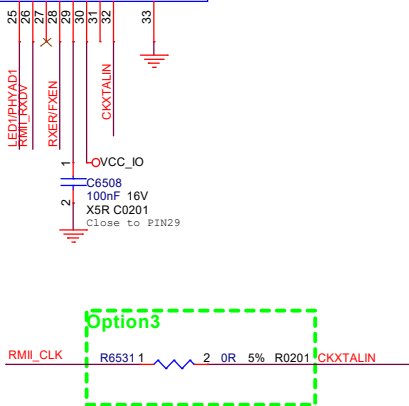

RMII REF_CLK direction

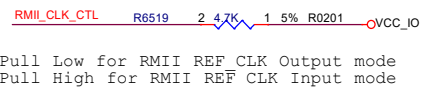

MII/RMII Selection

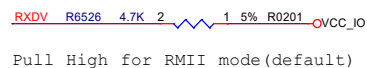

UTP / Fiber Selection

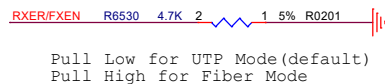

PHY Address/LED



WOL/LED0 Selection

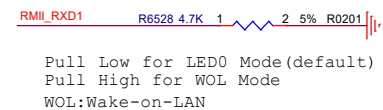

POWER

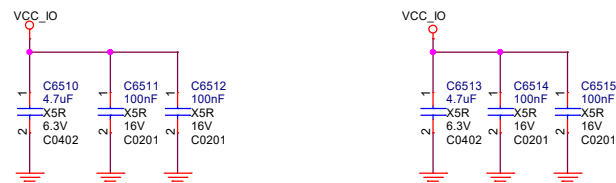

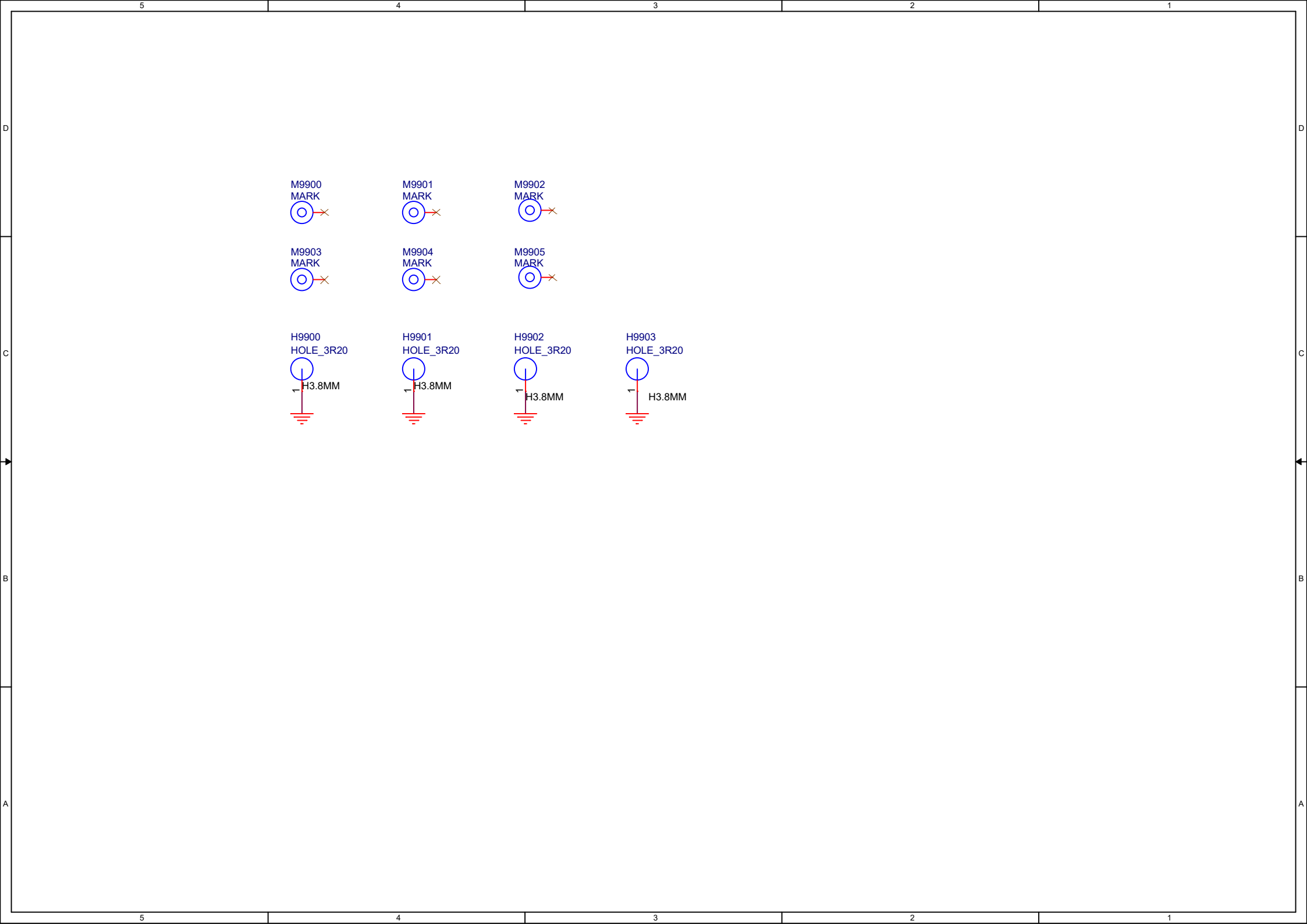

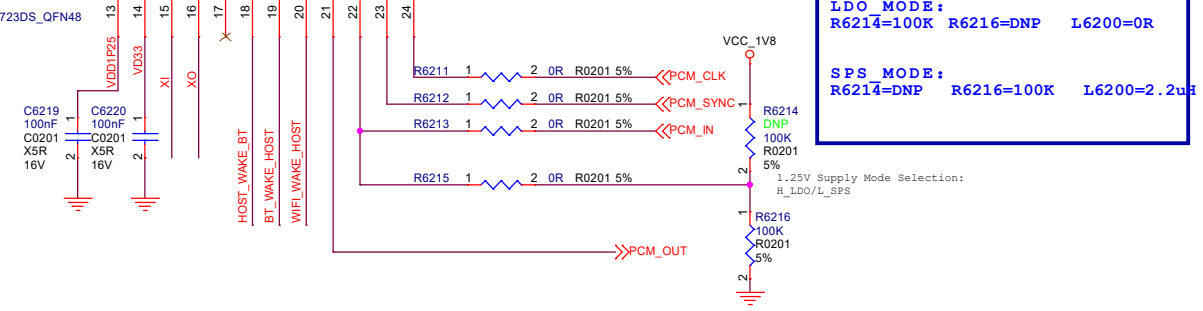
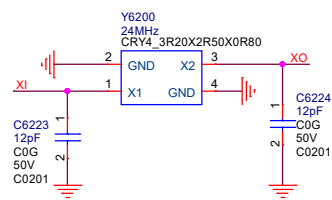
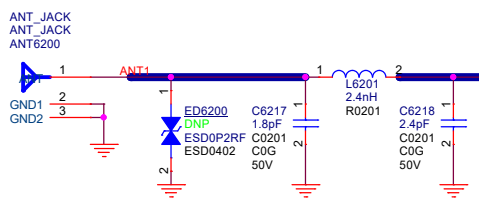
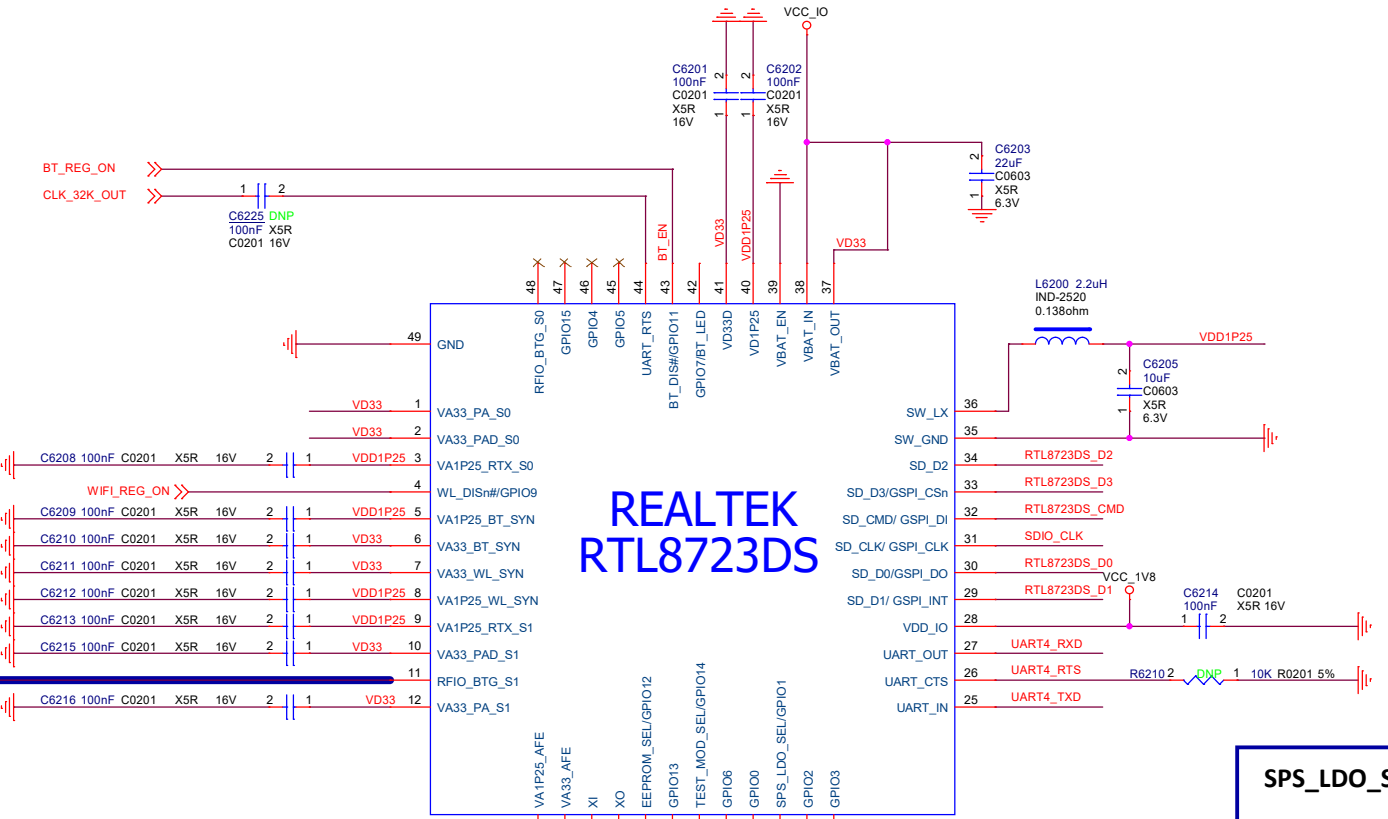
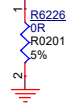
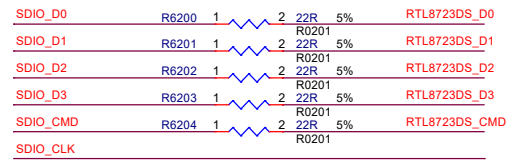

SPS_LDO_SEL

LDO MODE:
R6214=100K R6216=DNP L6200=0R

SPS MODE:
R6214=DNP R6216=100K L6200=2.2uH

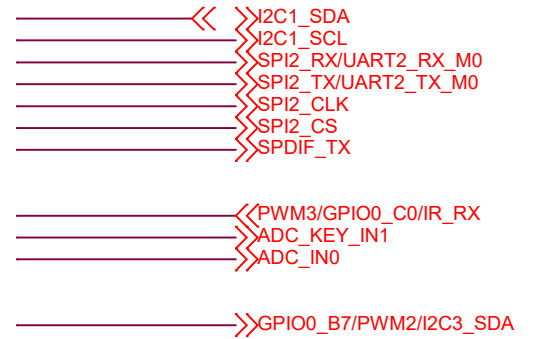
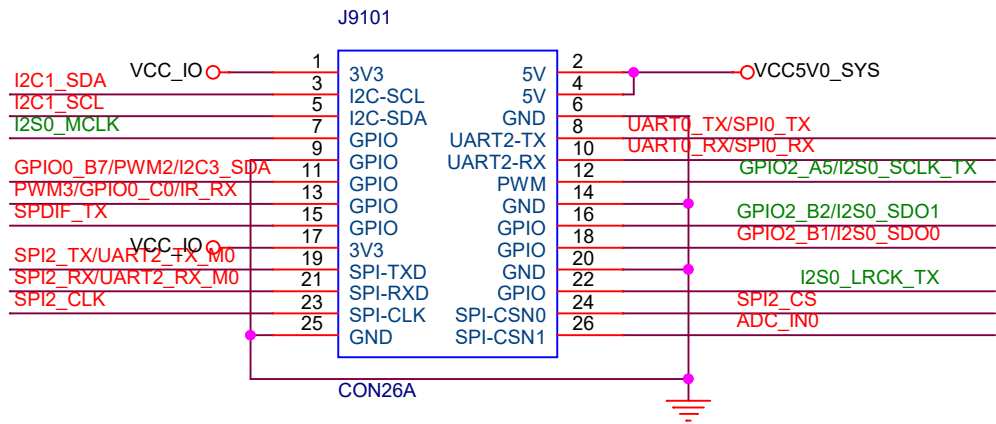

GPIO2_A5/I2S0_SCLK_TX

