

# TEST REPORT

Report No.: BCTC2111530025-6E

---

Applicant: ROCKPI TRADING LIMITED

---

Product Name: Radxa Zero

---

Model/Type Ref.: D4E16H

---

Tested Date: 2021-11-05 to 2021-11-24

---

Issued Date: 2021-12-08

---

**Shenzhen BCTC Testing Co., Ltd.**



Product Name: Radxa Zero  
Trademark: N/A  
Model/Type Ref.: D4E16H  
D4E16T, D4E32H, D4E64H, D4E128H  
Prepared For: ROCKPI TRADING LIMITED  
Address: Room 11, 27/f, Ga wah international centre, 191 Javaroad, north point, Hong Kong, China  
Manufacturer: ROCKPI TRADING LIMITED  
Address: Room 11, 27/f, Ga wah international centre, 191 Javaroad, north point, Hong Kong, China  
Prepared By: Shenzhen BCTC Testing Co., Ltd.  
Address: 1-2/F., Building B, Pengzhou Industrial Park, No.158, Fuyuan 1st Road, Tangwei, Fuhai Subdistrict, Bao'an District, Shenzhen, Guangdong, China  
Sample Received Date: 2021-11-05  
Sample tested Date: 2021-11-05 to 2021-11-24  
Issue Date: 2021-12-08  
Report No.: BCTC2111530025-6E  
Test Standards: ETSI EN 301 893 V2.1.1 (2017-05)  
Test Results: PASS  
Remark: This is WIFI-5.1GHz band radio test report.

Tested by:



Lei Chen/Project Handler

Approved by:



Zero Zhou/Reviewer

The test report is effective only with both signature and specialized stamp. This result(s) shown in this report refer only to the sample(s) tested. Without written approval of Shenzhen BCTC Testing Co., Ltd, this report can't be reproduced except in full. The tested sample(s) and the sample information are provided by the client.

## Table Of Content

Test Report Declaration	Page
1. Version .....	5
2. Test Summary .....	6
3. Measurement Uncertainty .....	7
4. Product Information And Test Setup .....	8
4.1 Product Information .....	8
4.2 Test Setup Configuration .....	8
4.3 Support Equipment .....	8
4.4 Channel List .....	9
4.5 Test Mode .....	9
4.6 Test Environment .....	9
5. Test Facility And Test Instrument Used .....	10
5.1 Test Facility .....	10
5.2 Test Instrument Used .....	10
6. Information As Required .....	11
7. Nominal Centre Frequencies .....	13
7.1 Block Diagram Of Test Setup .....	13
7.2 Limit .....	13
7.3 Test Procedure .....	13
7.4 Test Result .....	14
8. Nominal Channel Bandwidth And Occupied Channel Bandwidth .....	17
8.1 Block Diagram Of Test Setup .....	17
8.2 Limit .....	17
8.3 Test Procedure .....	17
8.4 Test Result .....	18
9. RF Output Power, Transmit Power Control (TPC) .....	22
9.1 Block Diagram Of Test Setup .....	22
9.2 Limit .....	22
9.3 Test Procedure .....	22
9.4 Test Result .....	24
10. Power Spectral Density .....	28
10.1 Block Diagram Of Test Setup .....	28
10.2 Limit .....	28
10.3 Test Procedure .....	28
10.4 Test Result .....	29
11. Transmitter Unwanted Emissions In The Spurious Domain .....	30
11.1 Block Diagram Of Test Setup .....	30
11.2 Limits .....	31
11.3 Test Procedure .....	31

11.4	Test Results	32
12.	Transmitter Unwanted Emissions In The Out-Of-Band Domain	33
12.1	Block Diagram Of Test Setup	33
12.2	Limit	33
12.3	Test Procedure	33
12.4	Test Result	34
13.	Receiver Spurious Emissions	48
13.1	Block Diagram Of Test Setup	48
13.2	Limits	48
13.3	Test Procedure	49
13.4	Test Results	50
14.	Adaptivity	51
14.1	Block Diagram Of Test Setup	51
14.2	Limit	51
14.3	Test Procedure	52
14.4	Test Result	52
15.	Receiver Blocking	53
15.1	Block Diagram Of Test Setup	53
15.2	Limit	53
15.3	Test Procedure	53
15.4	Test Result	54
16.	User Access Restrictions	55
16.1	Applicable Standard	55
16.2	Conformance Limit	55
16.3	Test Results	55
17.	EUT Photographs	56
18.	EUT Test Setup Photographs	60

(Note: N/A Means Not Applicable)

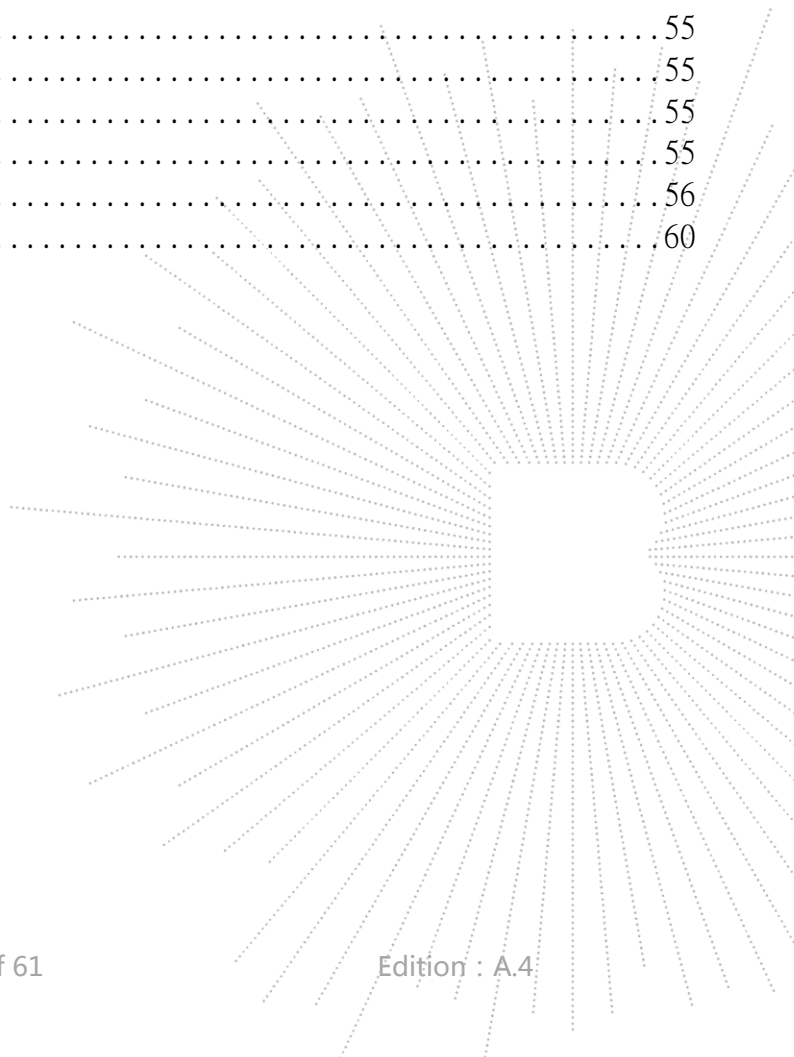

**1. Version**

<b>Report No.</b>	<b>Issue Date</b>	<b>Description</b>	<b>Approved</b>
BCTC2111530025-6E	2021-12-08	Original	Valid

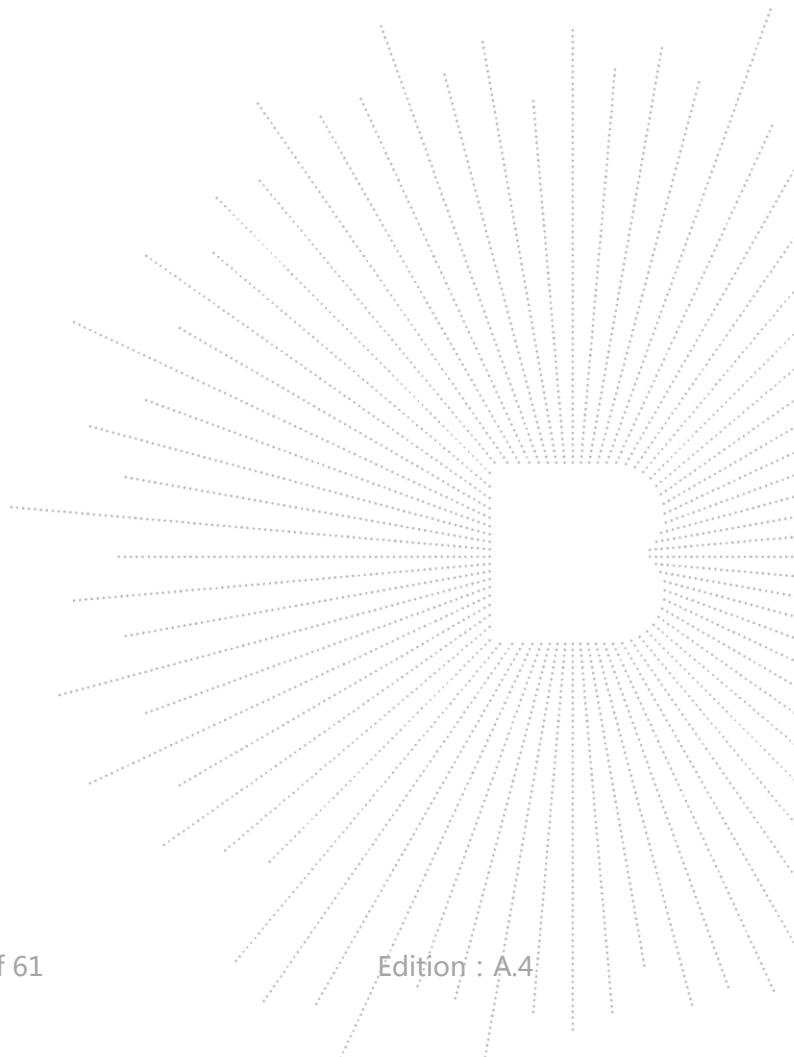

## 2. Test Summary

The Product has been tested according to the following specifications:

No.	Test Parameter	Clause No	Results
1	Nominal Centre frequencies	4.2.1	PASS
2	Nominal Channel Bandwidth and Occupied Channel Bandwidth	4.2.2	PASS
3	RF output power, Transmit Power Control (TPC) and Power Density	4.2.3	PASS
4	Transmitter unwanted emissions	4.2.4	PASS
5	Receiver spurious emissions	4.2.5	PASS
6	Dynamic Frequency Selection (DFS)	4.2.6	N/A
7	Adaptivity (Channel Access Mechanism)	4.2.7	N/A
8	Receiver Blocking	4.2.8	PASS
9	User Access Restrictions	4.2.9	PASS

Note: N/A is an abbreviation for Not Applicable and means this test item is not applicable for this device according to the technology characteristic of device.

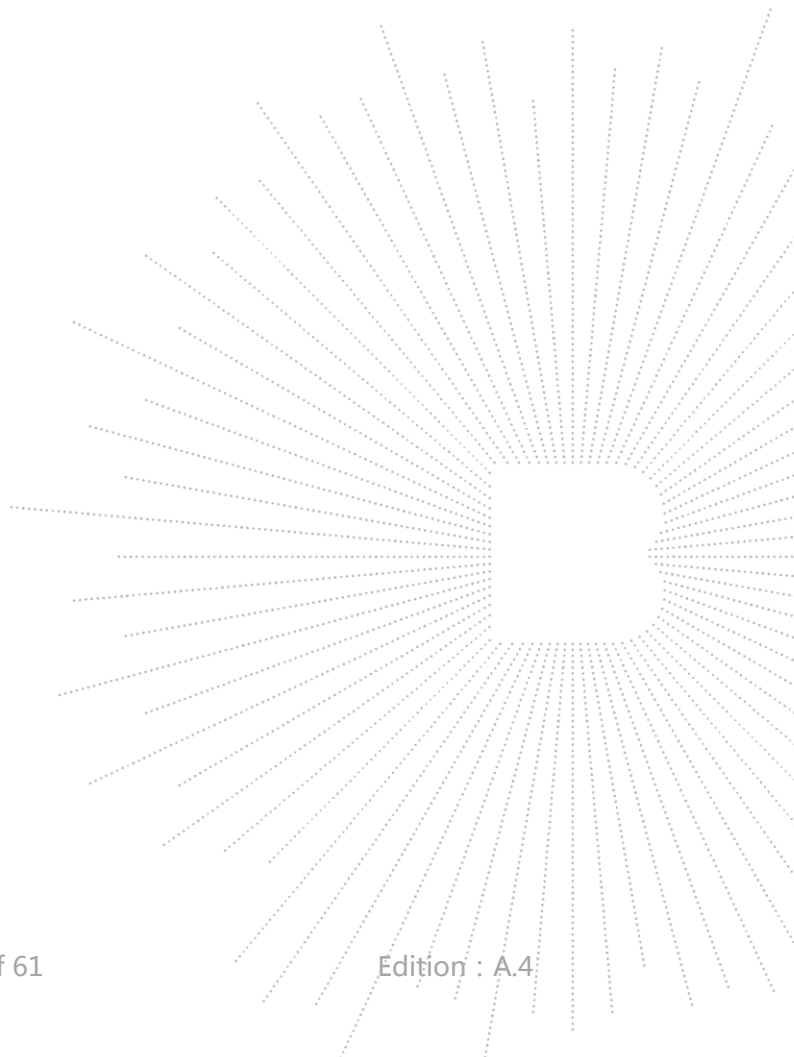

### 3. Measurement Uncertainty

Where relevant, the following measurement uncertainty levels have been estimated for tests performed on the Product as specified in CISPR 16-4-2. This uncertainty represents an expanded uncertainty expressed at approximately the 95% confidence level using a coverage factor of  $k=2$ .

RF frequency	$1 \times 10^{-7}$
RF power, conducted	$\pm 1.0$ dB
Conducted emission of receivers	$\pm 1$ dB
Radiated emission of transmitter	$\pm 6$ dB
Radiated emission of receiver	$\pm 6$ dB
Temperature	$\pm 1$ degree
Humidity	$\pm 5$ %

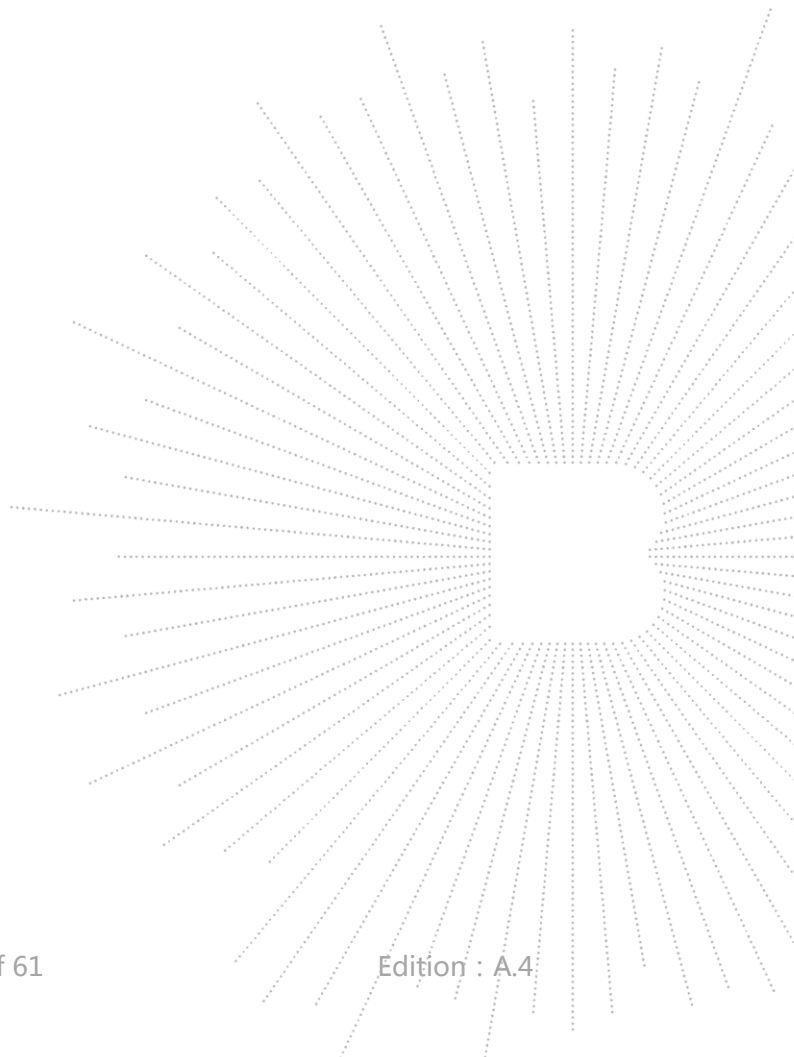

## 4. Product Information And Test Setup

### 4.1 Product Information

Model/Type Ref.:	D4E16H D4E16T, D4E32H, D4E64H, D4E128H
Model differences:	All the model are the same circuit and RF module, except model names.
Wi-Fi Specification:	IEEE 802.11a/b/g/n/ac
Operation Frequency:	WiFi (5.1G): IEEE 802.11a/n/ac HT20/HT40/HT80:5180-5240MHz
Max. RF output power:	WiFi (5.1G):13.97 dBm
Type of Modulation:	WiFi: DSSS, OFDM
Antenna installation:	Chip antenna
Antenna Gain:	WiFi (5.1G): 2dBi
Ratings:	DC 5V from USB

#### Cable of Product

No.	Cable Type	Quantity	Provider	Length (m)	Shielded	Note
1	--	--	Applicant	---	Yes/No	With a ferrite ring in mid Detachable
2	--	--	BCTC	--	Yes/No	--

### 4.2 Test Setup Configuration

See test photographs attached in EUT TEST SETUP PHOTOGRAPHS for the actual connections between Product and support equipment.

### 4.3 Support Equipment

No.	Device Type	Brand	Model	Series No.	Note
1.	---	---	---	---	---

#### Notes:

- All the equipment/cables were placed in the worst-case configuration to maximize the emission during the test.
- Grounding was established in accordance with the manufacturer's requirements and conditions for the intended use.



#### 4.4 Channel List

CH	Frequency (MHz)	CH	Frequency (MHz)	CH	Frequency (MHz)	CH	Frequency (MHz)
36	5180	38	5190	40	5200	42	5210
44	5220	46	5230	48	5240		

#### 4.5 Test Mode

All test mode(s) and condition(s) mentioned were considered and evaluated respectively by performing full tests, the worst data were recorded and reported.

Test mode	Low channel	Middle channel	High channel
Transmitting(802.11a HT20)	5180MHz	5200 MHz	5240 MHz
Transmitting(802.11n HT20)	5180MHz	5200 MHz	5240 MHz
Transmitting(802.11n HT40)	5190Mhz	/	5230 MHz
Transmitting(802.11ac HT20)	5190Mhz	5590MHz	5230 MHz
Transmitting(802.11ac HT40)	5190Mhz	/	5230 MHz
Transmitting(802.11ac HT80)	/	5200 MHz	/
Receiving(802.11a HT20)	5180MHz	5200 MHz	5240 MHz
Receiving(802.11n HT20)	5180MHz	5200 MHz	5240 MHz
Receiving(802.11n HT40)	5190Mhz	/	5230 MHz
Receiving(802.11ac HT20)	5190Mhz	5590MHz	5230 MHz
Receiving(802.11ac HT40)	5190Mhz	/	5230 MHz
Receiving(802.11ac HT80)	/	5210 MHz	/

#### 4.6 Test Environment

##### 1. Normal Test Conditions:

Humidity(%):	54
Atmospheric Pressure(kPa):	101
Temperature(°C):	26
Test Voltage(DC):	5V

##### 2. Extreme Test Conditions:

For tests at extreme temperatures, measurements shall be made over the extremes of the operating temperature range as declared by the manufacturer.

Test Conditions	LT	HT
Temperature (°C)	0	35

## 5. Test Facility And Test Instrument Used

### 5.1 Test Facility

All measurement facilities used to collect the measurement data are located at Shenzhen BCTC Testing Co., Ltd. Address: 1-2/F., Building B, Pengzhou Industrial Park, No.158, Fuyuan 1st Road, Tangwei, Fuhai Subdistrict, Bao'an District, Shenzhen, Guangdong, China. The site and apparatus are constructed in conformance with the requirements of ANSI C63.4 and CISPR 16-1-1 other equivalent standards.

### 5.2 Test Instrument Used

Item	Equipment	Manufacturer	Type No.	Serial No.	Last calibration	Calibrated until
1	966 chamber	ChengYu	966 Room	966	Jun. 06. 2020	Jun. 05, 2023
2	Receiver	R&S	ESR3	102075	May 28, 2021	May 27, 2022
3	Spectrum Analyzer	Agilent	E4407B	MY45109572	May 28, 2021	May 27, 2022
4	Amplifier	SKET	LAPA_01G18 G-45dB	\	May 28, 2021	May 27, 2022
5	Amplifier	Schwarzbeck	BBV9744	9744-0037	May 28, 2021	May 27, 2022
6	TRILOG Broadband Antenna	Schwarzbeck	VULB 9163	942	Jun. 01, 2021	May 31, 2022
7	Horn Antenna	Schwarzbeck	BBHA9120D	1541	Jun. 02, 2021	Jun. 01, 2022
8	band rejection filter	ZBSF	ZBSF-C2441. 5	1706003606	May 28, 2021	May 27, 2022
9	Signal Generator	Keysight	N5181A	MY50143748	Jun. 29, 2021	Jun. 28, 2022
10	Communication test set	R&S	CMU200	119435	May 28, 2021	May 27, 2022
11	Spectrum Analyzer	Keysight	N9020A	MY49100060	May 28, 2021	May 27, 2022
12	Signal Generator	Keysight	N5182B	MY56200519	May 28, 2021	May 27, 2022
13	Power Meter	Keysight	E4419	\	May 28, 2021	May 27, 2022
14	Power Sensor	Keysight	E9300A	\	May 28, 2021	May 27, 2022
15	Horn antenna	Schwarzbeck	BBHA9170	00822	Jun. 15, 2021	Jun. 14, 2022
16	Preamplifier	MITEQ	TTA1840-35- HG	2034381	May 28, 2021	May 27, 2022
17	Software	Frad	EZ-EMC	FA-03A2 RE	\	\
18	Software	Keysight	Keysight.ETS LTest system	1.02.05	\	\
19	D.C. Power Supply	LongWei	TPR-6405D	\	\	\
20	Loop Antenna	Schwarzbeck	FMZB1519B	00014	Jun. 02, 2021	Jun. 01, 2022
21	Communication test set	Agilent	N4010A	MY49081107	May 28, 2021	May 27, 2022
22	Programmable constant temperature and humidity test chamber	DGBELL	BTKS5-150C	\	Jul. 06, 2021	Jul. 05, 2022

## 6. Information As Required

### ETSI EN 301 893 V2.1.1 Annex G

<b>a) The Nominal Channel Bandwidth(s):</b>
Refer to section 4.4 channel list.
<b>b) For Load Based Equipment that supports multi-channel operation:</b>
N/A
<b>c) The different transmit operating modes (see clause 5.3.3.2) (tick all that apply):</b>
<input type="checkbox"/> Operating mode 1: Single Antenna Equipment
<input type="checkbox"/> a) Equipment with only 1 antenna
<b>d) In case of Smart Antenna Systems or multiple antenna systems:</b>
<ul style="list-style-type: none"> <li>• The number of Receive chains: .....</li> <li>• The number of Transmit chains: .....</li> <li>• Equal power distribution among the transmit chains: <input type="checkbox"/> Yes <input type="checkbox"/> No</li> <li>• In case of beamforming, the maximum (additional) beamforming gain: ..... dB</li> </ul> NOTE: Beamforming gain does not include the basic gain of a single antenna (assembly).
<b>e) TPC feature available:</b>
<input type="checkbox"/> Yes <input checked="" type="checkbox"/> No
<b>f) For equipment with TPC range:</b>
The lowest and highest power level (or lowest and highest e.i.r.p. level in case of integrated antenna equipment), intended antenna assemblies and corresponding operating frequency range for the TPC range (or for each of the TPC ranges if more than one is implemented).
<b>g) For equipment without a TPC range:</b>
Power Setting 1: Max.
<b>h) The DFS related operating mode(s) of the equipment:</b>
N/A
<b>i) User access restrictions (please check box below to confirm):</b>
N/A
<b>j) For equipment with Off-Channel CAC functionality:</b>
N/A
<b>k) The equipment can operate in ad-hoc mode:</b>
N/A
<b>l) Operating Frequency Range(s):</b>
Refer to section 4.1.
<b>m) The extreme operating temperature and supply voltage range that apply to the equipment:</b>
Refer to section 4.6
<b>n) The test sequence/test software used (see also ETSI EN 301 893 (V2.1.1), clause 5.3.1.2):</b>
Provide by manufacturer.
<b>o) Type of Equipment:</b>
<input checked="" type="checkbox"/> Stand-alone
<input type="checkbox"/> Combined Equipment (Equipment where the radio part is fully integrated within another type of equipment)
<input type="checkbox"/> Plug-in radio device (Equipment intended for a variety of host systems)
<input type="checkbox"/> Other .....
<b>p) Adaptivity (Channel Access Mechanism):</b>
<input type="checkbox"/> Frame Based Equipment
<input checked="" type="checkbox"/> Load Based Equipment
<b>q) With regards to Adaptivity for Frame Based Equipment</b>
<input type="checkbox"/> The Frame Based Equipment operates as an Initiating Device
<input type="checkbox"/> The Frame Based Equipment operates as an Responding Device
<input type="checkbox"/> The Frame Based Equipment can operate as an Initiating Device and as a Responding Device
<b>r) With regards to Adaptivity for Load Based Equipment</b>
N/A
<b>s) The equipment supports a geo-location capability as defined in clause 4.2.10 of ETSI EN 301</b>

<b>893 V2.1.1:</b>
<input type="checkbox"/> Yes <input checked="" type="checkbox"/> No
<b>t) The minimum performance criteria (see ETSI EN 301 893 V2.1.1, clause 4.2.8.3) that corresponds to the intended use of the equipment:</b>
The minimum performance criterion is a PER of less than or equal to 10 %.
<b>u) The theoretical maximum radio performance of the equipment (e.g. maximum throughput) (see ETSI EN 301 893 V2.1.1, clause 5.4.9.3.1):</b>
N/A

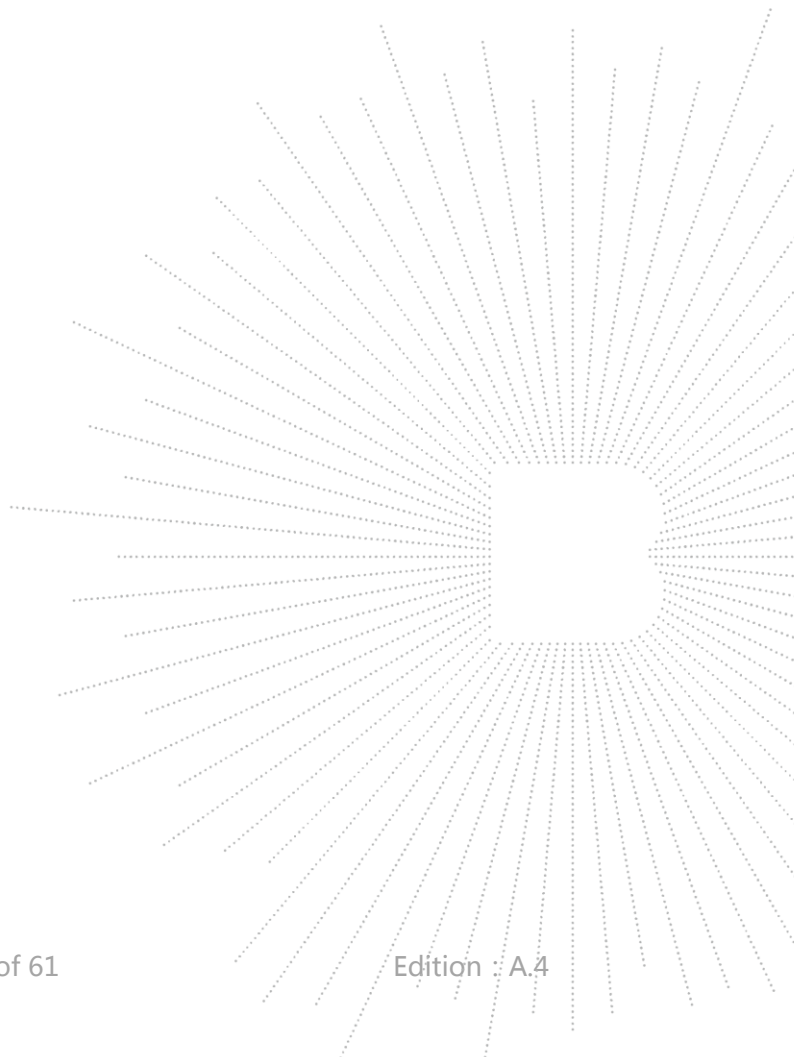

## 7. Nominal Centre Frequencies

### 7.1 Block Diagram Of Test Setup

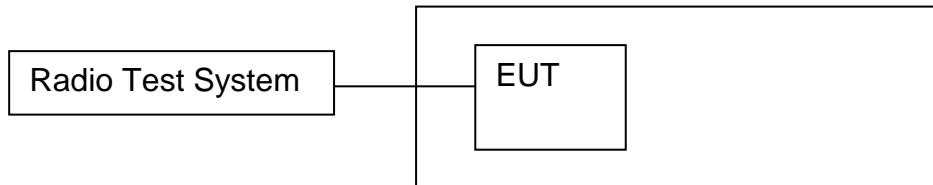

### 7.2 Limit

The Nominal Centre Frequencies ( $f_c$ ) for a Nominal Channel Bandwidth of 20 MHz are defined by equation (1). See also figure 3.

$f_c = 5\,160 + (g \times 20)$  MHz, where  $0 \leq g \leq 9$  or  $16 \leq g \leq 27$  and where  $g$  shall be an integer.

A maximum offset of the Nominal Centre Frequency of  $\pm 200$  kHz is permitted. Where the manufacturer decides to make use of this frequency offset, the manufacturer shall declare the actual centre frequencies used by the equipment.

See clause 5.4.1, item a).

The actual centre frequency for any given channel shall be maintained within the range  $f_c \pm 20$  ppm.

Equipment may have simultaneous transmissions on more than one Operating Channel with a Nominal Channel Bandwidth of 20 MHz.

### 7.3 Test Procedure

This method is an alternative to the above method in case the UUT cannot be operated in an un-modulated mode.

The UUT shall be connected to spectrum analyzer.

Max Hold shall be selected and the centre frequency adjusted to that of the UUT.

The peak value of the power envelope shall be measured and noted. The span shall be reduced and the marker moved in a positive frequency increment until the upper, (relative to the centre frequency), -10 dBc point is reached. This value shall be noted as  $f_1$ .

The marker shall then be moved in a negative frequency increment until the lower, (relative to the centre frequency), -10 dBc point is reached. This value shall be noted as  $f_2$ .

The centre frequency is calculated as  $(f_1 + f_2) / 2$ .

## 7.4 Test Result

Modulation	Test conditions		Frequency Measured (MHz)		
			Low channel	Middle channel	High channel
			5180.0000	5200.0000	5240.0000
Unmodulation	Normal		5179.9800	5199.9800	5239.9800
	Extreme	LTLV	5179.9825	5199.9849	5239.9843
		LTHV	5179.9873	5199.9850	5239.9858
		HTLV	5179.9919	5199.9887	5239.9885
		HTHV	5179.9949	5199.9937	5239.9906
Max.Error(ppm)			-3.86	-3.85	-3.82
Limit (ppm)			±20	±20	±20

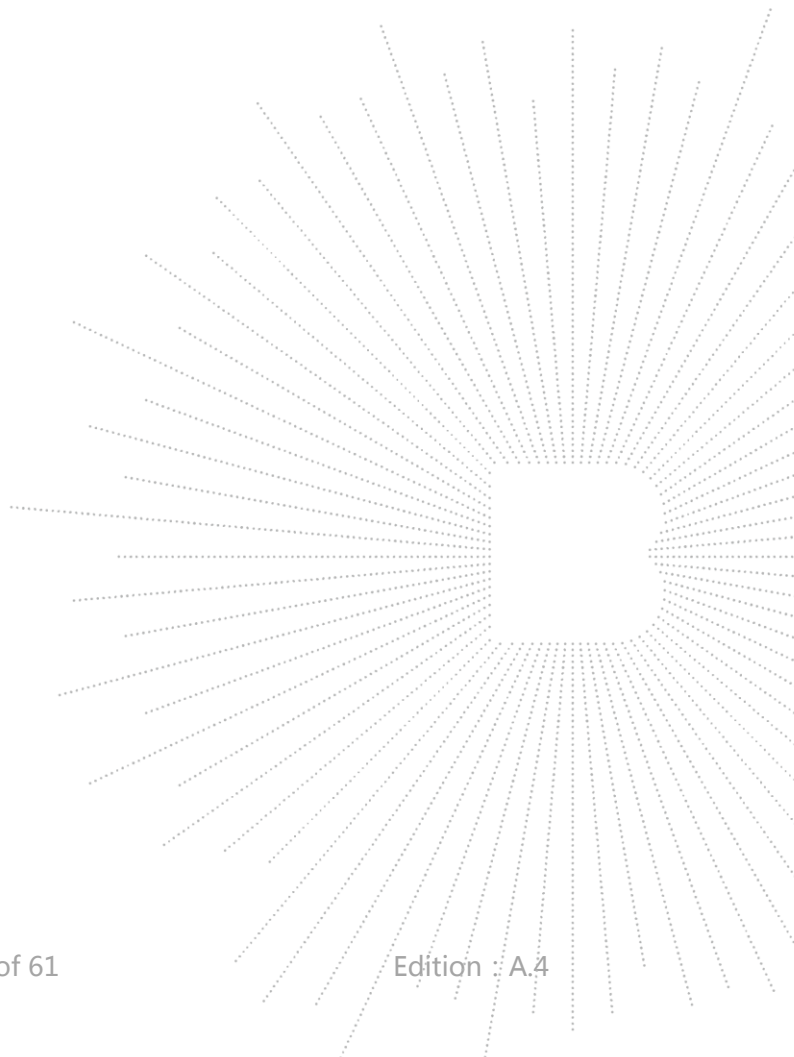

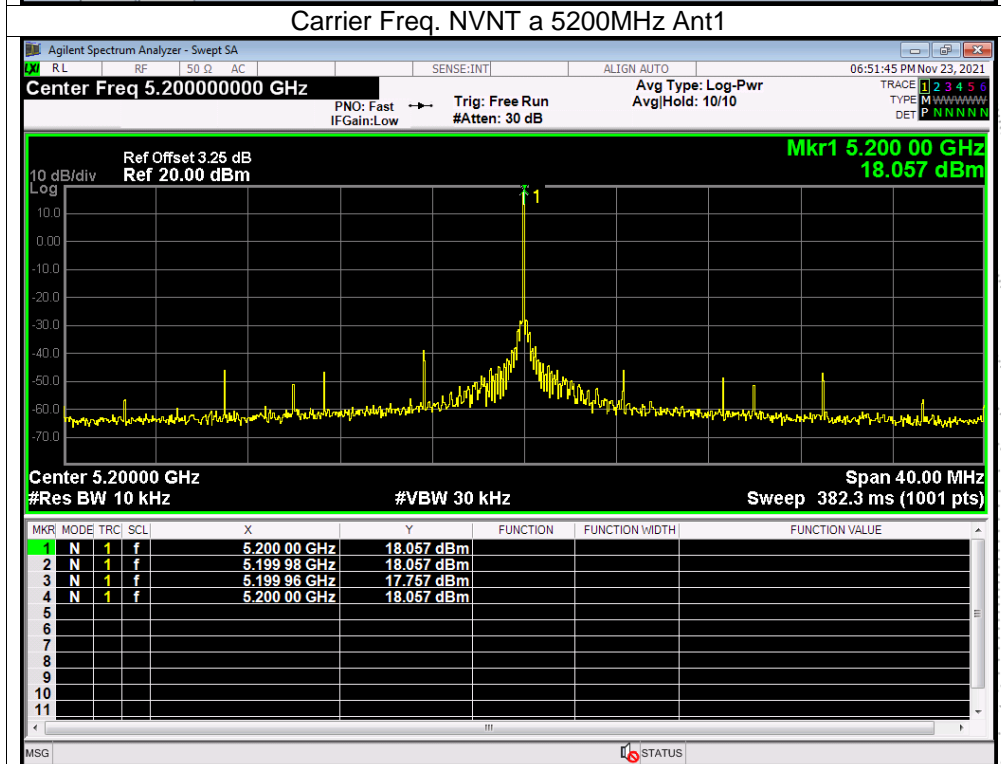
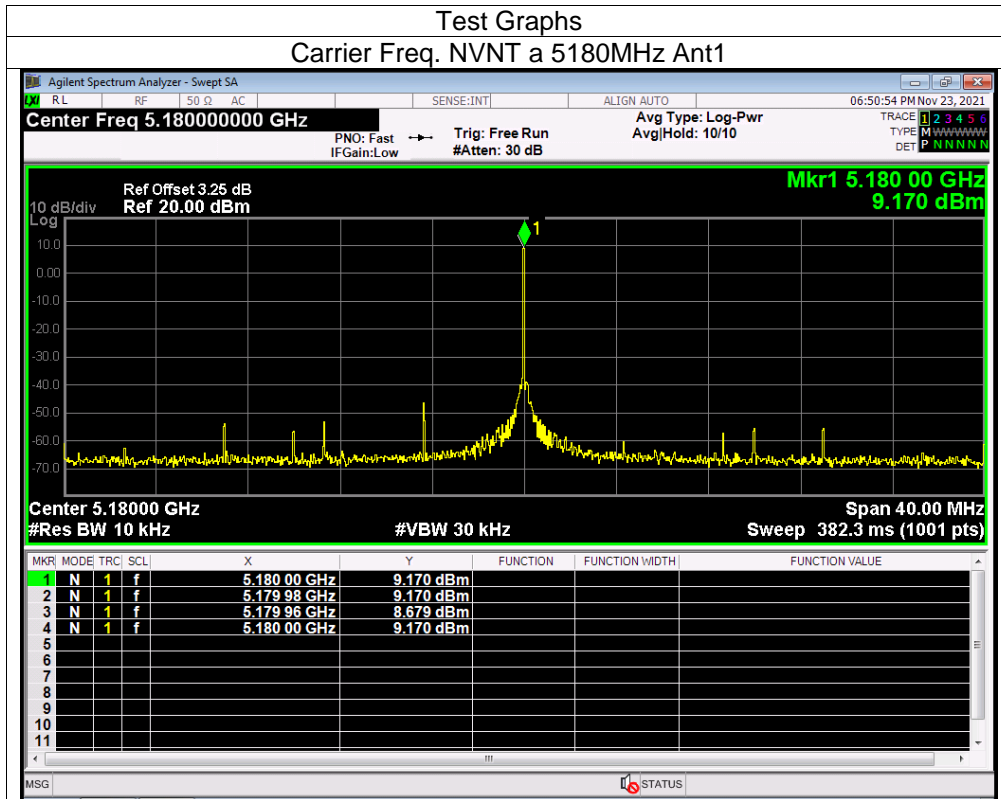



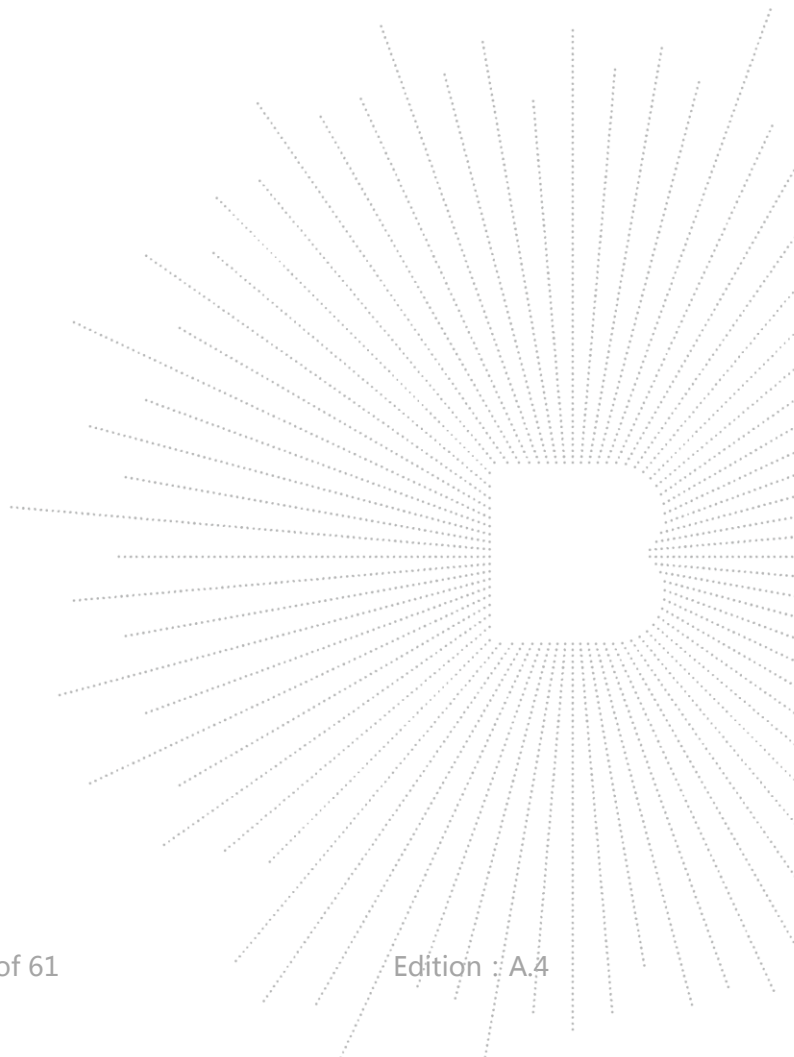
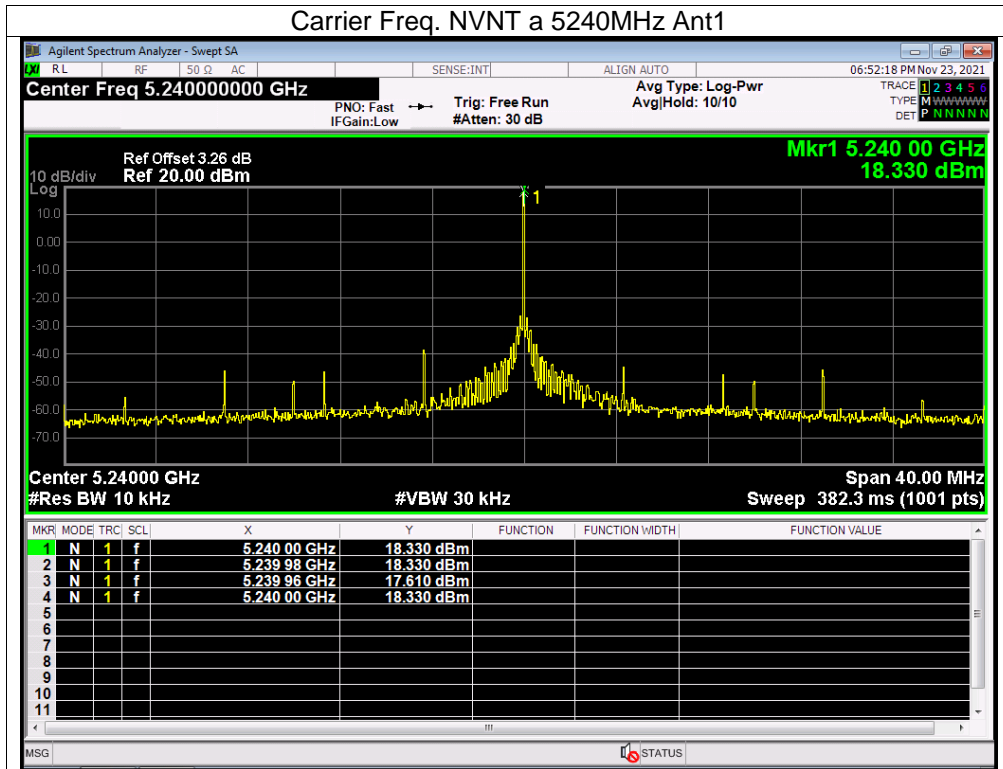



## 8. Nominal Channel Bandwidth And Occupied Channel Bandwidth

### 8.1 Block Diagram Of Test Setup

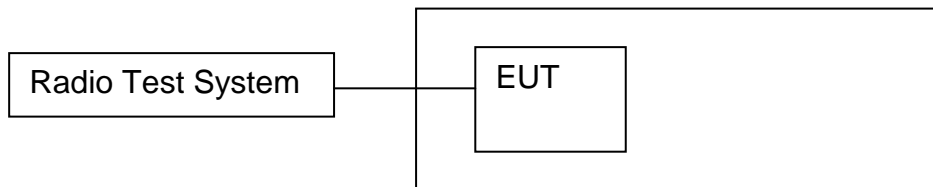

### 8.2 Limit

The Nominal Channel Bandwidth for a single Operating Channel shall be 20 MHz. Alternatively, equipment may implement a lower Nominal Channel Bandwidth with a minimum of 5 MHz, providing they still comply with the Nominal Centre Frequencies defined in clause 4.2.1 (20 MHz raster). The Occupied Channel Bandwidth shall be between 80 % and 100 % of the Nominal Channel Bandwidth. In case of smart antenna systems (devices with multiple transmit chains) each of the transmit chains shall meet this requirement.

The Occupied Channel Bandwidth might change with time/payload.

### 8.3 Test Procedure

#### Step 1:

- Connect the UUT to the spectrum analyzer and use the following settings:
  - Centre Frequency: The centre frequency of the channel under test
  - Resolution Bandwidth: 100 kHz
  - Video Bandwidth: 300 kHz
  - Frequency Span: 2 × Nominal Bandwidth (e.g. 40 MHz for a 20 MHz channel)
  - Sweep time: > 1 s; for larger Nominal Bandwidths, the sweep time may be increased until a value where the sweep time has no impact on the RMS value of the signal
  - Detector Mode: RMS
  - Trace Mode: Max Hold

#### Step 2:

- Wait for the trace to stabilize.

#### Step 3:

- Make sure that the power envelope is sufficiently above the noise floor of the analyzer to avoid the noise signals left and right from the power envelope being taken into account by this measurement.
- Use the 99 % bandwidth function of the spectrum analyzer to measure the Occupied Channel Bandwidth of the UUT. This value shall be recorded.

The measurement described in step 1 to step 3 above shall be repeated in case of simultaneous transmissions in non-adjacent channels.

## 8.4 Test Result

Modulation	Test conditions	OCCUPIED CHANNEL BANDWIDTH (MHz)		
		Low Channel	Middle Channel	High Channel
802.11a HT20	Normal	16.416	16.407	16.418
802.11n HT20	Normal	17.624	17.618	17.626
802.11n HT40	Normal	36.141	/	36.175
802.11ac HT20	Normal	17.628	17.620	17.627
802.11ac HT40	Normal	36.121	/	36.158
802.11ac HT80	Normal	/	75.627	/

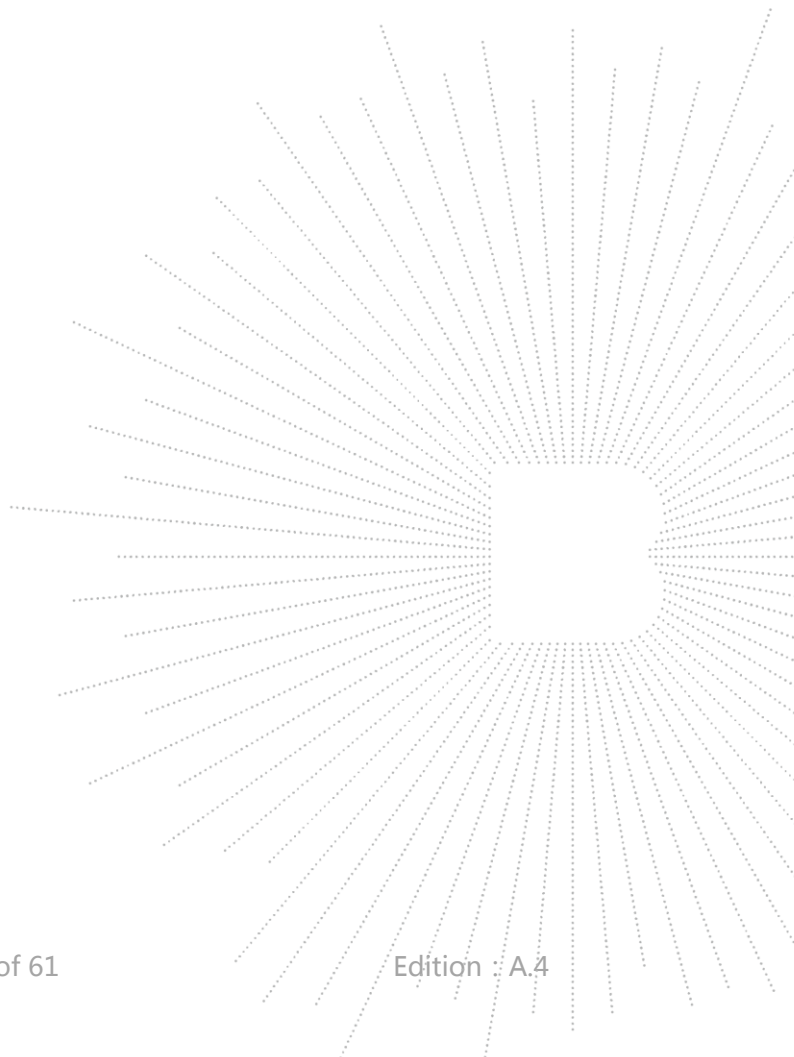

Test Plots  
802.11a Low Channel

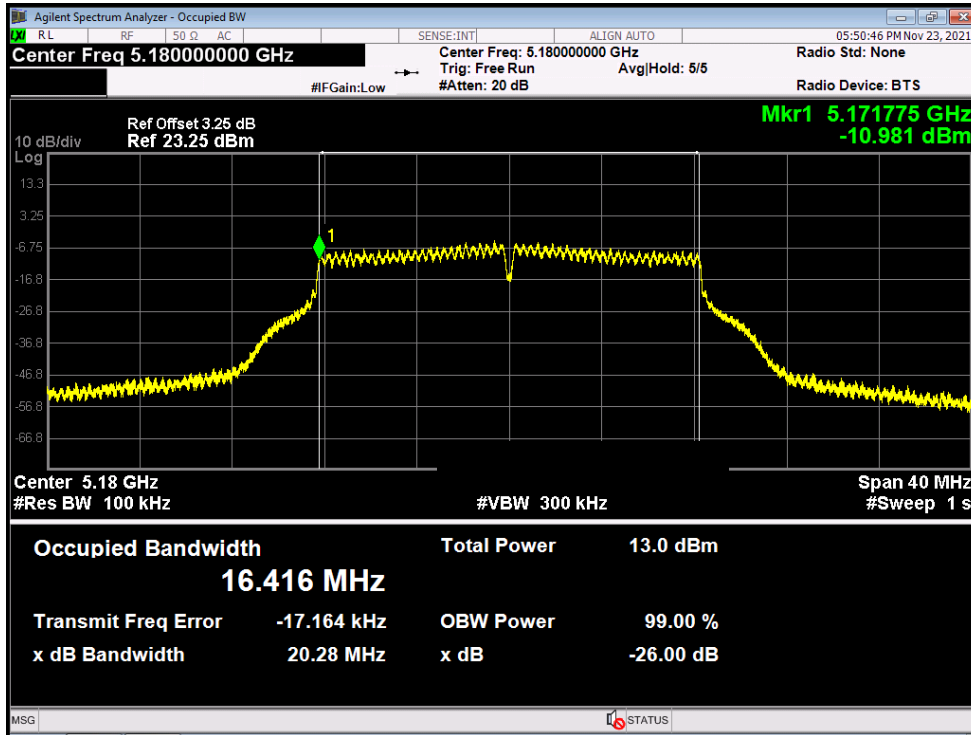

802.11n HT20 Low Channel

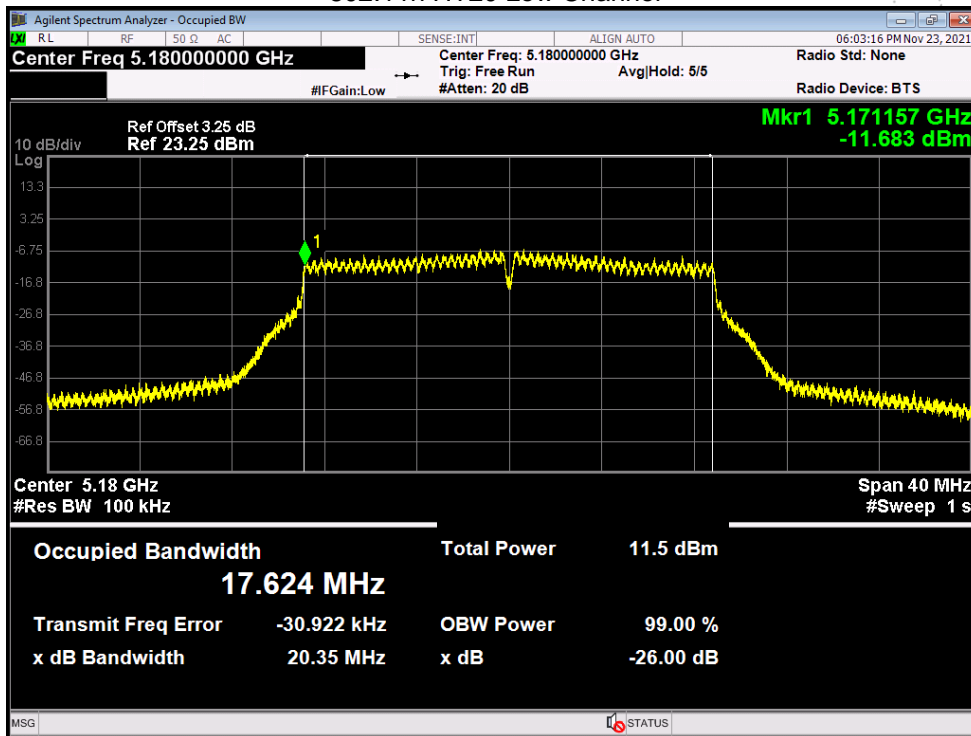

## 802.11n HT40 Low Channel

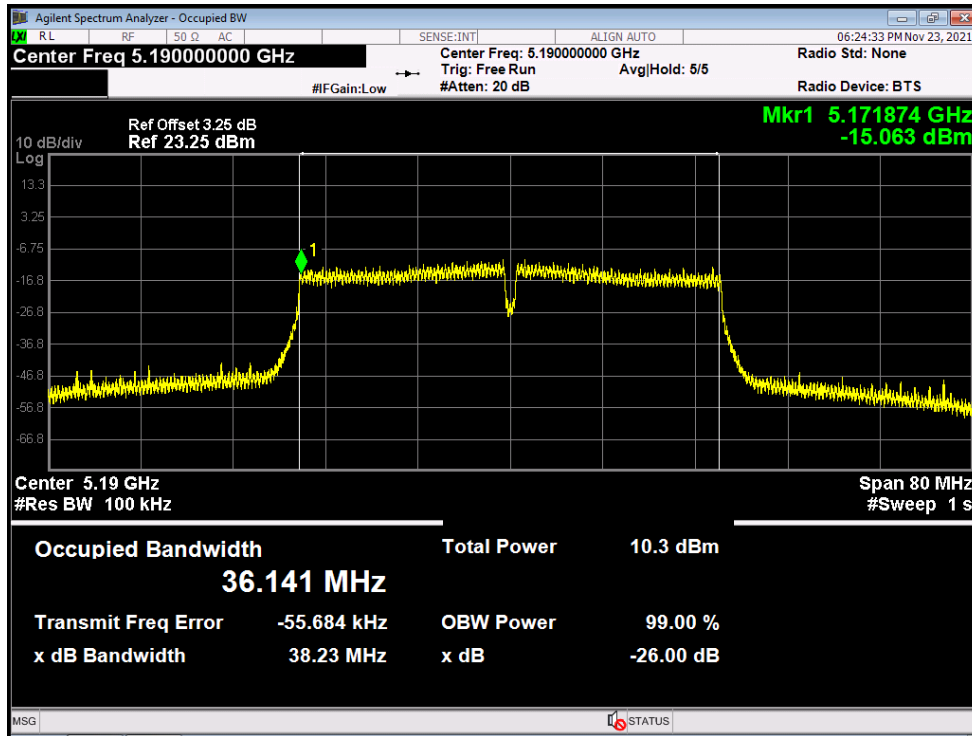

## 802.11ac HT20 Low Channel

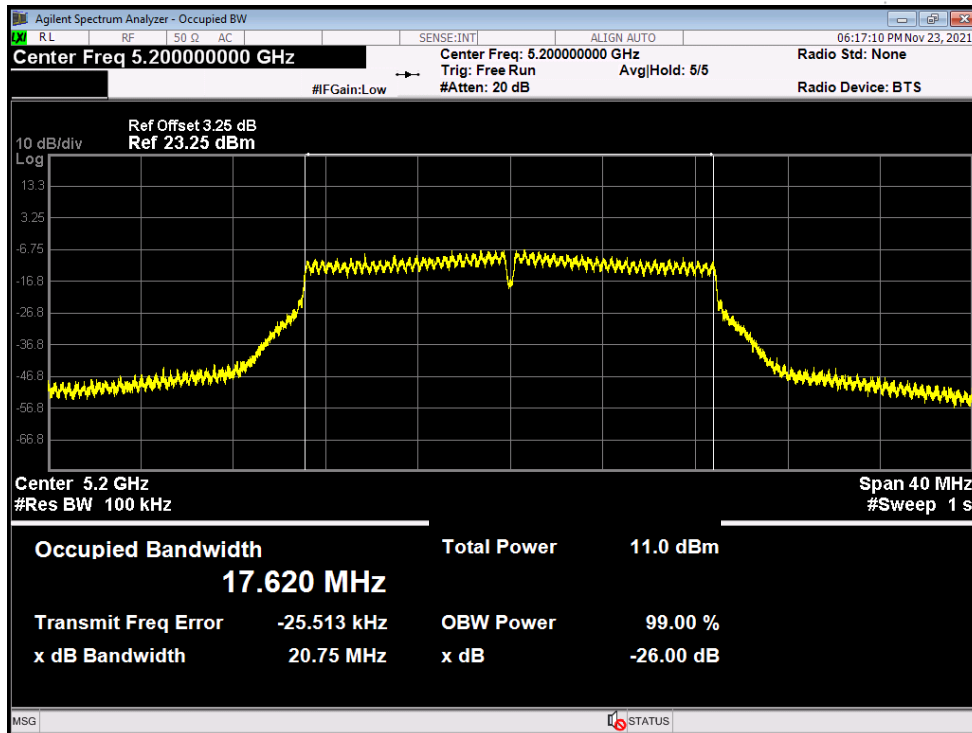

## 802.11ac HT40 Low Channel

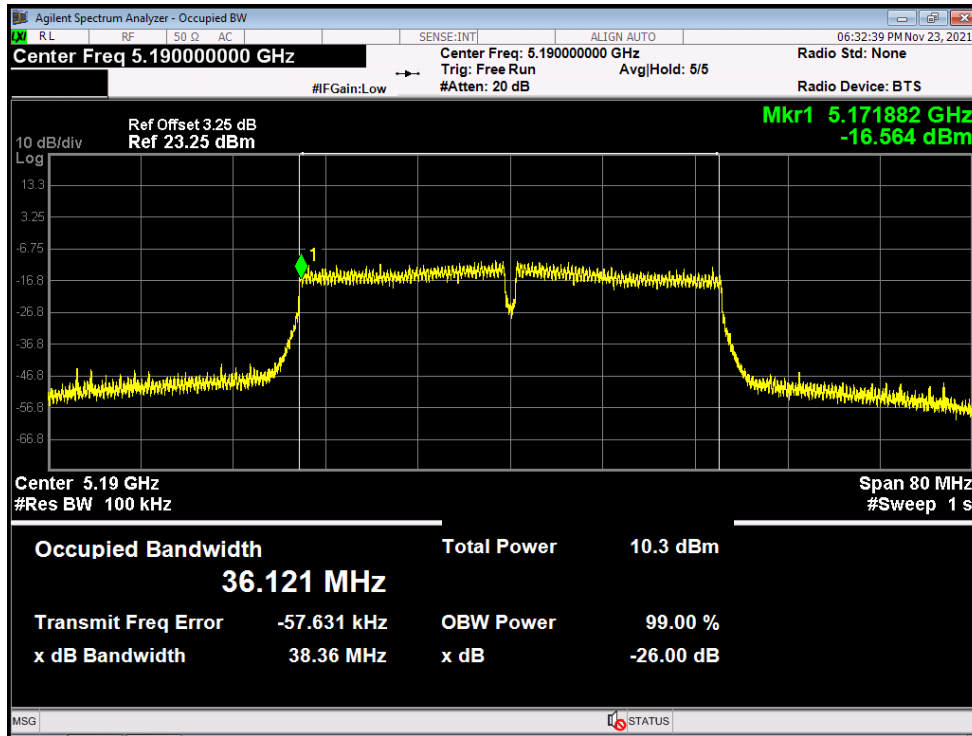

## 802.11ac HT80 Low Channel

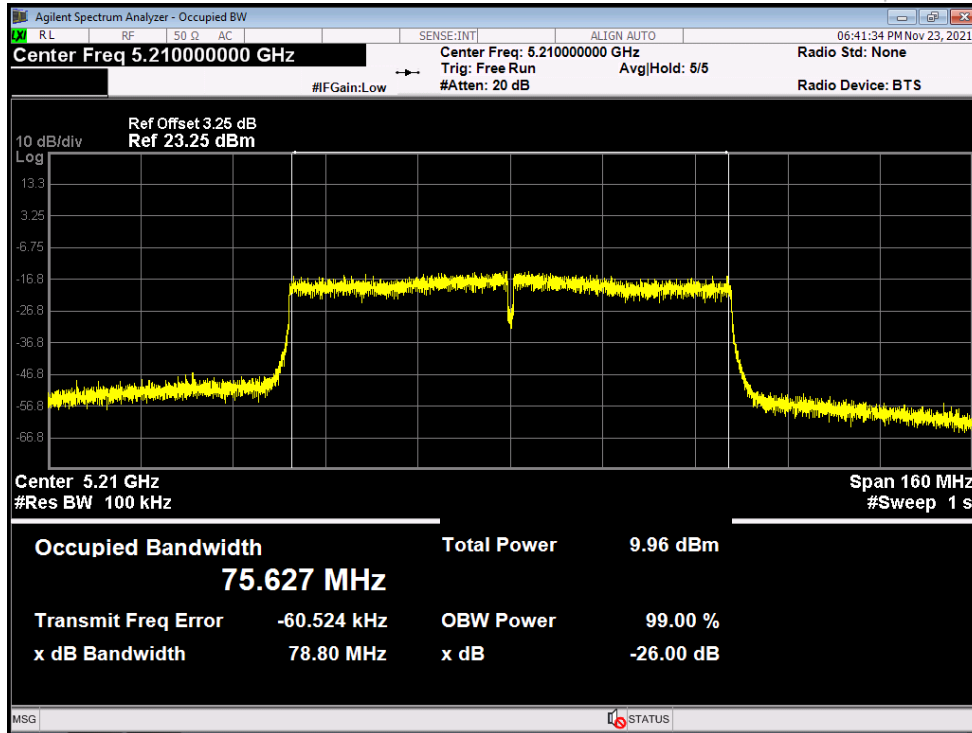

## 9. RF Output Power, Transmit Power Control (TPC)

### 9.1 Block Diagram Of Test Setup

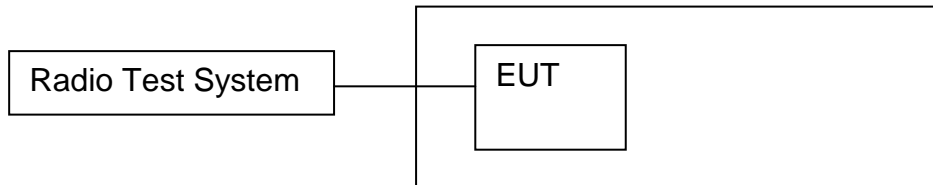

### 9.2 Limit

Frequency range (MHz)	Mean e.i.r.p. limit for $P_H$ (dBm)		Mean e.i.r.p. density limit (dBm/MHz)	
	with TPC	without TPC	with TPC	without TPC
5 150 to 5 350	23	20/23 (see note 1)	10	7/10 (see note 2)
5 470 to 5 725	30 (see note 3)	27 (see note 3)	17 (see note 3)	14 (see note 3)

NOTE 1: The applicable limit is 20 dBm, except for transmissions whose nominal bandwidth falls completely within the band 5 150 MHz to 5 250 MHz, in which case the applicable limit is 23 dBm.

NOTE 2: The applicable limit is 7 dBm/MHz, except for transmissions whose nominal bandwidth falls completely within the band 5 150 MHz to 5 250 MHz, in which case the applicable limit is 10 dBm/MHz.

NOTE 3: Slave devices without a *Radar Interference Detection* function shall comply with the limits for the frequency range 5 250 MHz to 5 350 MHz.

### 9.3 Test Procedure

This option is for equipment that operates only in one sub-band or that is capable for operation in two sub-bands simultaneously but, for the purpose of the testing, the equipment can be configured to:

- operate in a continuous transmit mode or with a constant duty cycle (x), and
- operate only in one sub-band.

#### Step 1:

- For equipment configured into a continuous transmit mode ( $x = 1$ ), proceed immediately with step 2.
- The output power of the transmitter shall be coupled to a matched diode detector or equivalent thereof. The output of the diode detector shall be connected to the vertical channel of an oscilloscope.
- The combination of the diode detector and the oscilloscope shall be capable of faithfully reproducing the duty cycle of the transmitter output signal.
- The observed duty cycle of the transmitter (Tx on / (Tx on + Tx off)) shall be noted as x ( $0 < x \leq 1$ ), and recorded in the test report.

**Step 2:**

- The RF output power shall be determined using a wideband RF power meter with a thermocouple detector or an equivalent thereof and with an integration period that exceeds the repetition period of the transmitter by a factor 5 or more. The observed value shall be noted as A (in dBm).
- In case of conducted measurements on smart antenna systems operating in a mode with multiple transmit chains active simultaneously, the output power of each transmit chain shall be measured separately to calculate the total power (value A in dBm) for the UUT.

**Step 3:**

- The RF output power at the highest power level PH (e.i.r.p.) shall be calculated from the above measured power output A (in dBm), the observed duty cycle x, the stated antenna gain G in dBi and if applicable the beamforming gain Y in dB, according to the formula below. This value shall be recorded in the test report.

If more than one antenna assembly is intended for this power setting or TPC range, the gain of the antenna assembly with the highest gain shall be used.

$$PH = A + G + Y + 10 \times \log (1 / x) \text{ (dBm)}. (5)$$

- This value PH shall be compared to the applicable limit contained in table 2 of clause 4.2.3.2.2.

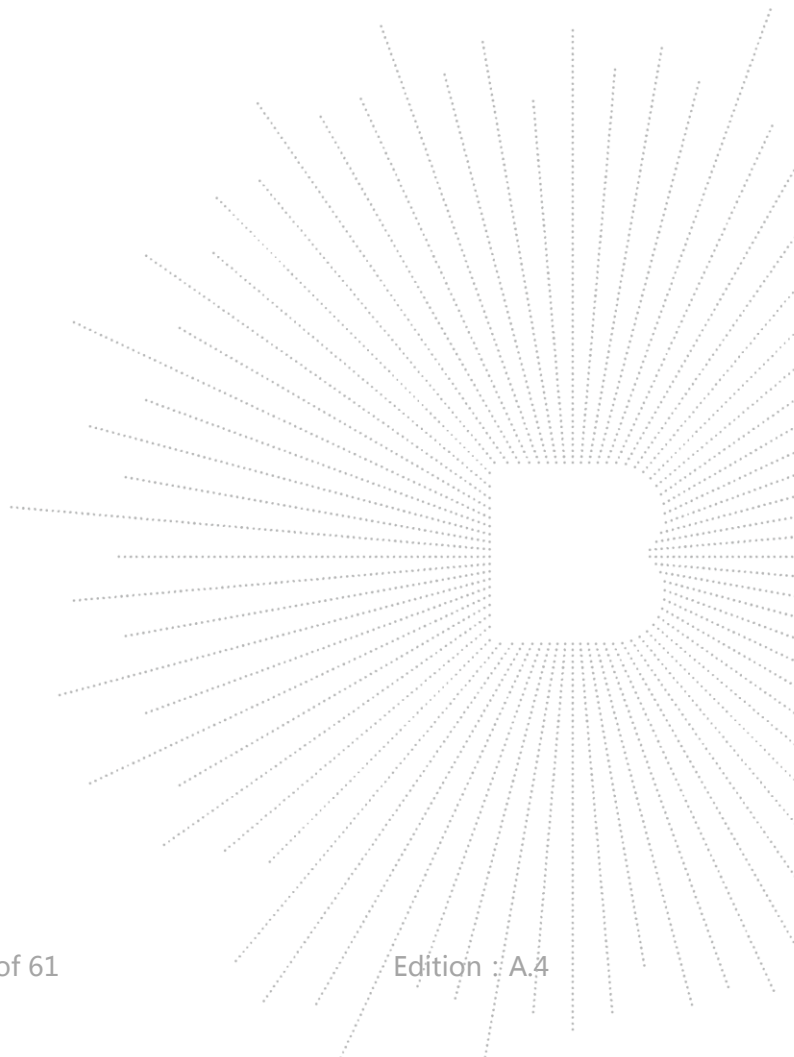

### 9.4 Test Result

Remark:  $PH = A + G + Y + 10 \times \log(1/x)$  (dBm)

Antenna Gain  $G=1$ dB<sub>i</sub>, beamforming gain  $Y=0$  dB, duty cycle  $X=100\%$

Modulation	Test conditions	e.i.r.p. (dBm)		
		Low channel	Middle channel	High channel
		EIRP	EIRP	EIRP
802.11a HT20	Normal	13.79	13.69	<b>13.97</b>
	LT	13.26	12.36	12.87
	HT	12.19	11.95	11.51
Limit		≤23dBm		

Modulation	Test conditions	e.i.r.p. (dBm)		
		Low channel	Middle channel	High channel
		EIRP	EIRP	EIRP
802.11n HT20	Normal	12.39	12.69	12.76
	LT	11.58	11.34	11.45
	HT	10.47	10.51	10.29
Limit		≤23dBm		

Modulation	Test conditions	e.i.r.p. (dBm)		
		Low channel	Middle channel	High channel
		EIRP	EIRP	EIRP
802.11n HT40	Normal	11.42	/	11.83
	LT	10.36	/	10.57
	HT	10.31	/	10.41
Limit		≤23dBm		

Modulation	Test conditions	e.i.r.p. (dBm)		
		Low channel	Middle channel	High channel
		EIRP	EIRP	EIRP
802.11ac HT20	Normal	12.50	12.66	12.73
	LT	11.74	11.41	12.37
	HT	10.61	10.96	11.49
Limit		≤23dBm		



Modulation	Test conditions	e.i.r.p. (dBm)		
		Low channel	Middle channel	High channel
		EIRP	EIRP	EIRP
802.11ac HT40	Normal	11.38	/	11.76
	LT	10.34	/	10.41
	HT	9.66	/	9.74
Limit		≤23dBm		

Modulation	Test conditions	e.i.r.p. (dBm)		
		Low channel	Middle channel	High channel
		EIRP	EIRP	EIRP
802.11ac HT80	Normal	/	11.38	/
	LT	/	10.75	/
	HT	/	9.48	/
Limit		≤23dBm		

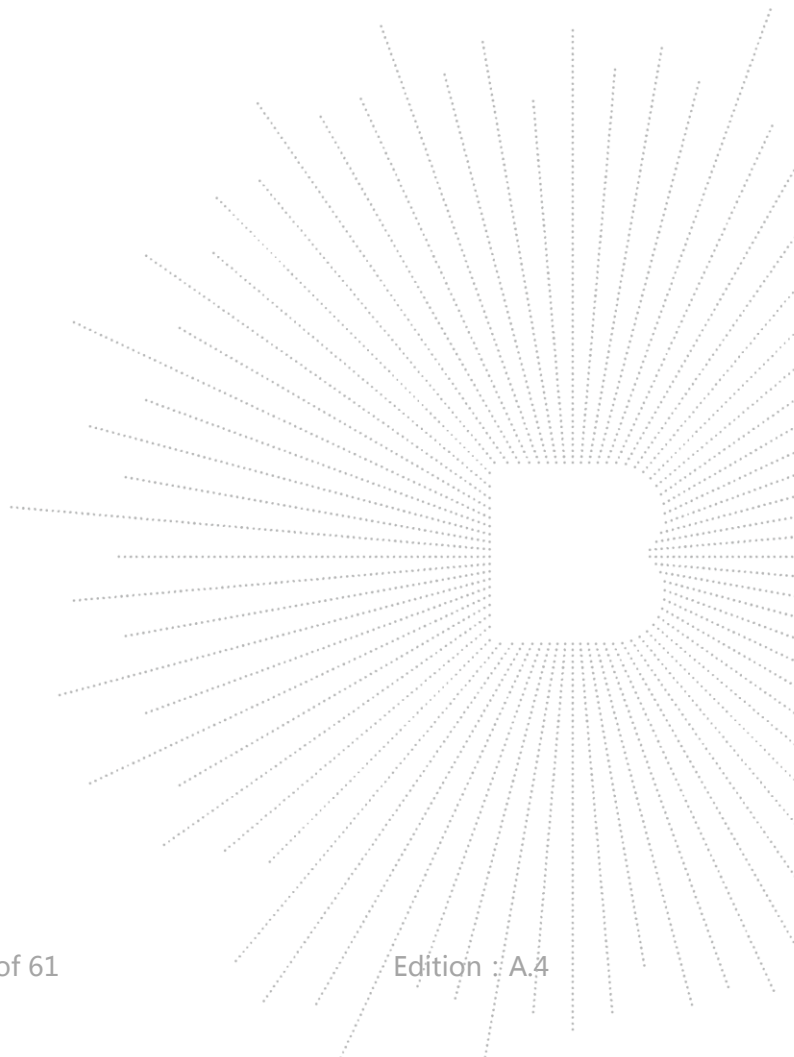

Test Plots (The worst data)  
802.11a Low channel

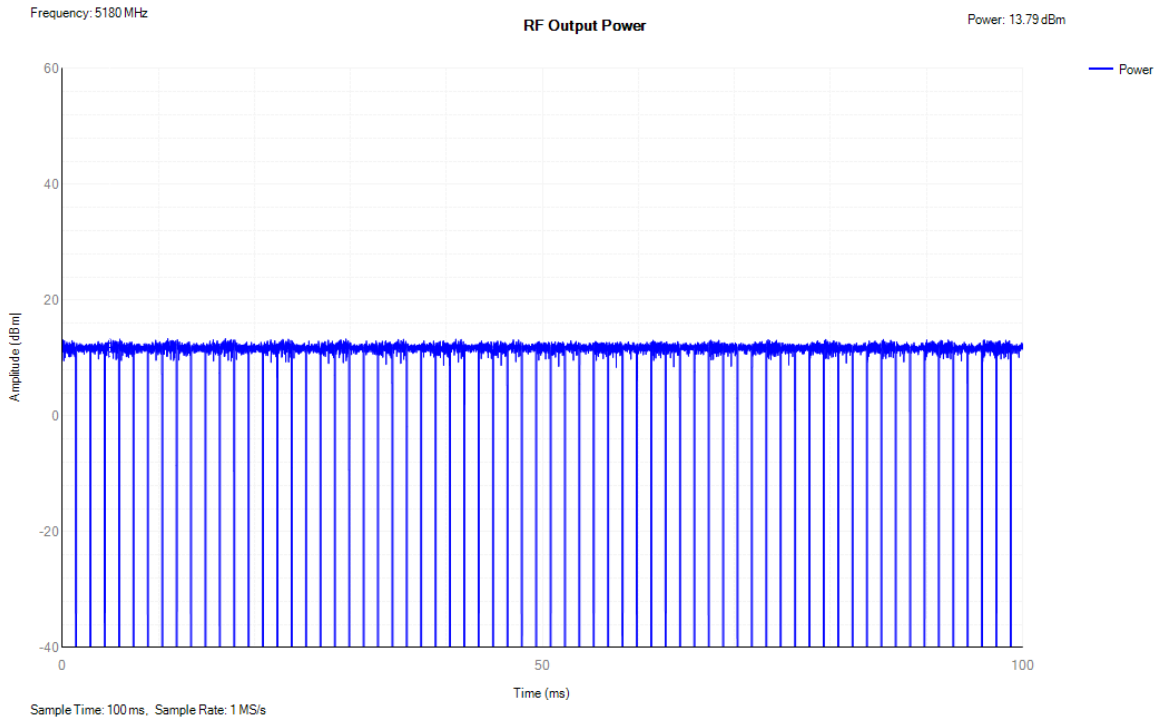

802.11a Mid channel

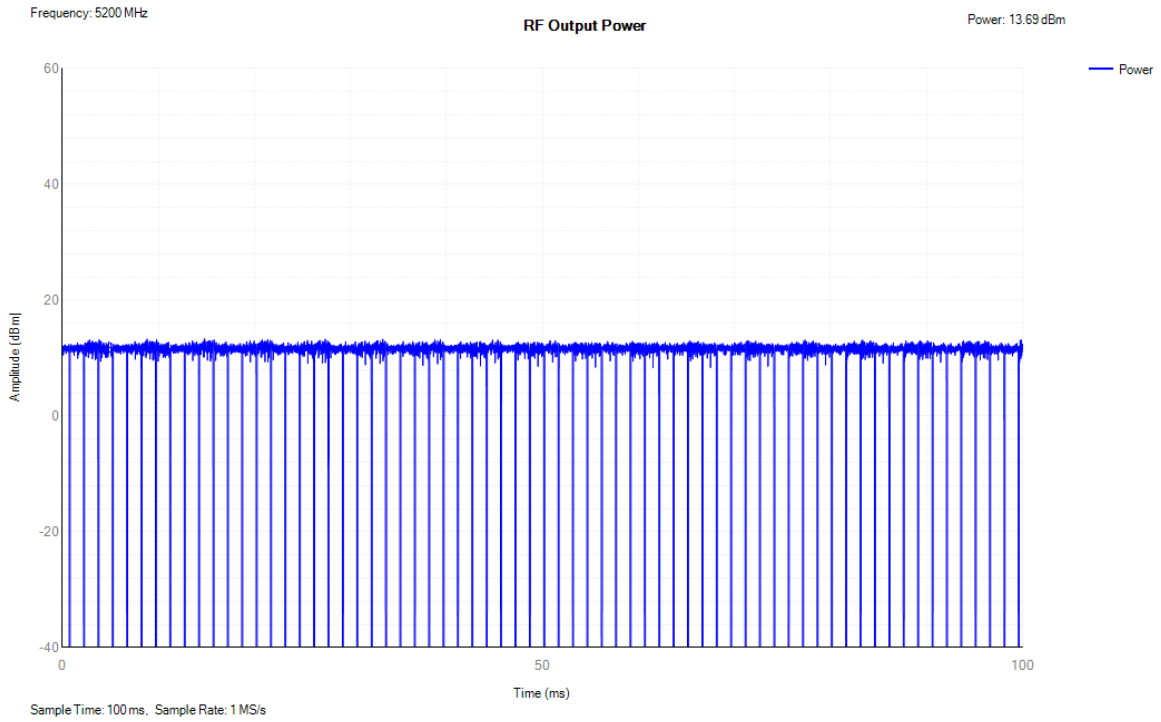

802.11a High channel

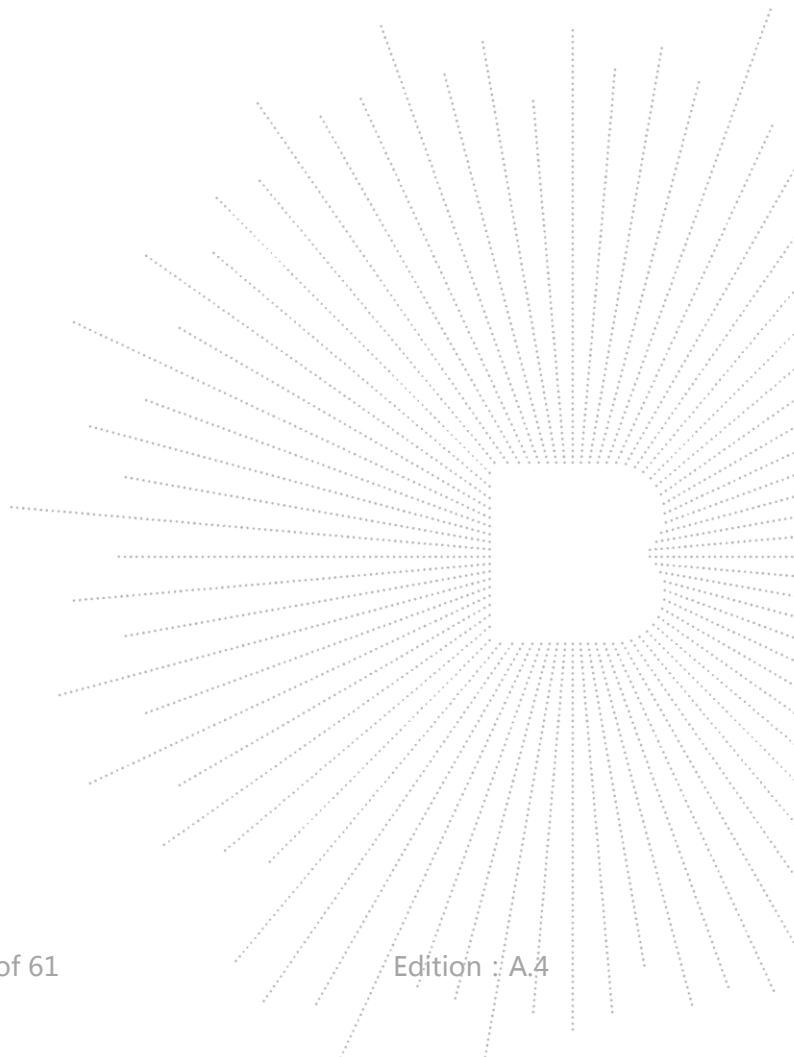
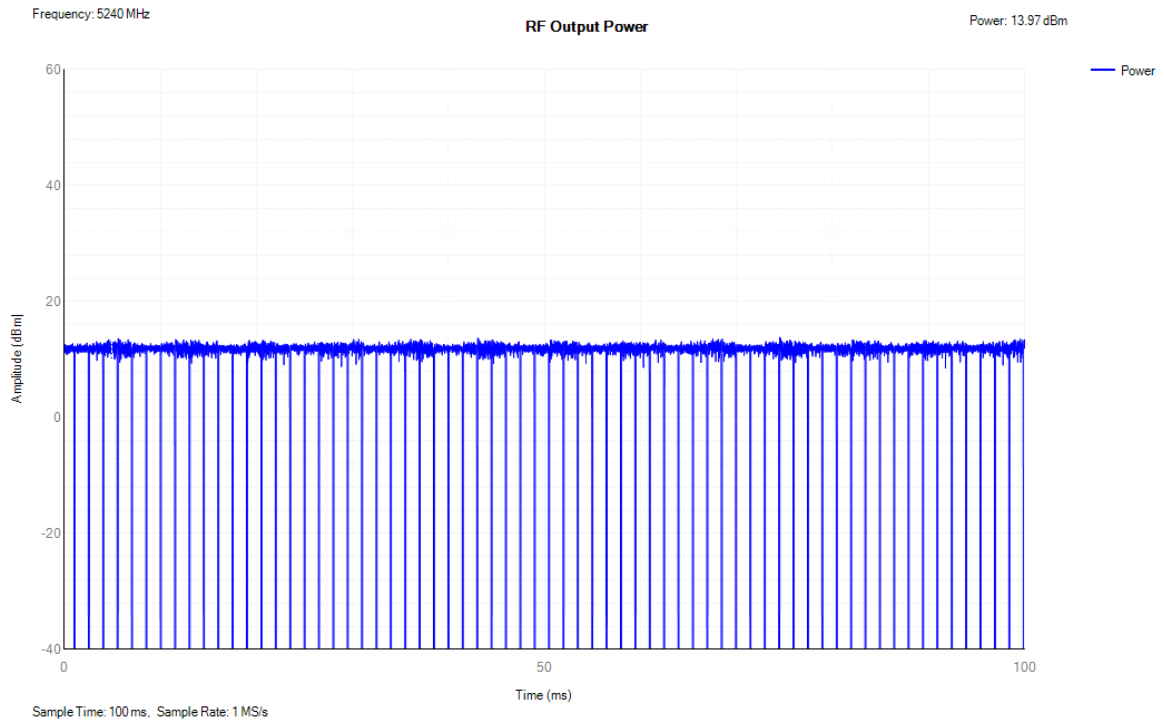

## 10. Power Spectral Density

### 10.1 Block Diagram Of Test Setup

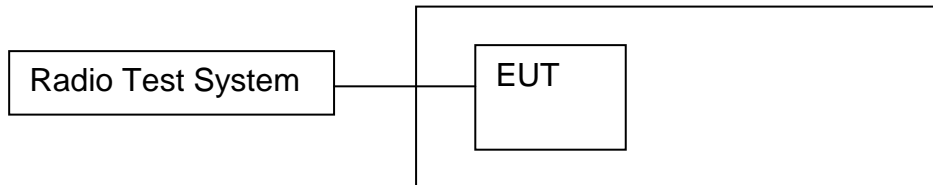

### 10.2 Limit

Frequency range (MHz)	Mean e.i.r.p. limit for $P_H$ (dBm)		Mean e.i.r.p. density limit (dBm/MHz)	
	with TPC	without TPC	with TPC	without TPC
5 150 to 5 350	23	20/23 (see note 1)	10	7/10 (see note 2)
5 470 to 5 725	30 (see note 3)	27 (see note 3)	17 (see note 3)	14 (see note 3)

NOTE 1: The applicable limit is 20 dBm, except for transmissions whose nominal bandwidth falls completely within the band 5 150 MHz to 5 250 MHz, in which case the applicable limit is 23 dBm.

NOTE 2: The applicable limit is 7 dBm/MHz, except for transmissions whose nominal bandwidth falls completely within the band 5 150 MHz to 5 250 MHz, in which case the applicable limit is 10 dBm/MHz.

NOTE 3: Slave devices without a *Radar Interference Detection* function shall comply with the limits for the frequency range 5 250 MHz to 5 350 MHz.

### 10.3 Test Procedure

This option is for equipment that can be configured to operate in a continuous transmit mode or with a constant duty cycle (x).

#### Step 1:

- Connect the UUT to the spectrum analyzer and use the following settings:
  - Centre Frequency: The centre frequency of the channel under test
  - RBW: 1 MHz
  - VBW: 3 MHz
  - Frequency Span: 2 x Nominal Bandwidth (e.g. 40 MHz for a 20 MHz channel)
  - Detector Mode: Peak
  - Trace Mode: Max Hold

#### Step 2:

- When the trace is complete, find the peak value of the power envelope and record the frequency.

#### Step 3:

- Make the following changes to the settings of the spectrum analyzer:
  - Centre Frequency: Equal to the frequency recorded in step 2
  - Frequency Span: 3 MHz
  - RBW: 1 MHz
  - VBW: 3 MHz
  - Sweep Time: 1 minute
  - Detector Mode: RMS
  - Trace Mode: Max Hold

**Step 4:**

- When the trace is complete, the trace shall be captured using the "Hold" or "View" option on the spectrum analyzer.
- Find the peak value of the trace and place the analyzer marker on this peak. This level is recorded as the highest mean power (Power Density) D in a 1 MHz band.
- Alternatively, where a spectrum analyzer is equipped with a function to measure spectral Power Density, this function may be used to display the Power Density D in dBm / MHz.
- In case of conducted measurements on smart antenna systems operating in a mode with multiple transmit chains active simultaneously, the Power Density of each transmit chain shall be measured separately to calculate the total Power Density (value D in dBm / MHz) for the UUT.

**Step 5:**

- The maximum spectral Power Density e.i.r.p. is calculated from the above measured Power Density D, the observed duty cycle x (see clause 5.4.4.2.1.1.2, step 1), the applicable antenna assembly gain G in dBi and if applicable the beamforming gain Y in dB, according to the formula below. This value shall be recorded in the test report. If more than one antenna assembly is intended for this power setting, the gain of the antenna assembly with the highest gain shall be used:  
 $PD = D + G + Y + 10 \times \log (1 / x)$  (dBm / MHz) (14)

## 10.4 Test Result

Remark:  $PH = A + G + Y + 10 \times \log (1 / x)$  (dBm)

G= Antenna Gain=1dBi, beamforming gain Y= 0 dB, duty cycle X=100%

Modulation	Test conditions	Power Density (dBm/MHz)		
		Low channel	Middle channel	High channel
802.11a	Normal	3.44	3.33	3.58
802.11n HT20	Normal	1.89	2.03	2.16
802.11n HT40	Normal	-2.16	/	-2.00
802.11ac HT20	Normal	1.83	1.76	1.96
802.11ac HT40	Normal	-2.26	/	-2.14
802.11ac HT80	Normal	/	-5.72	/
Limit		10dBm/MHz		

## 11. Transmitter Unwanted Emissions In The Spurious Domain

### 11.1 Block Diagram Of Test Setup

(A) Radiated Emission Test Set-Up Frequency Below 1GHz.

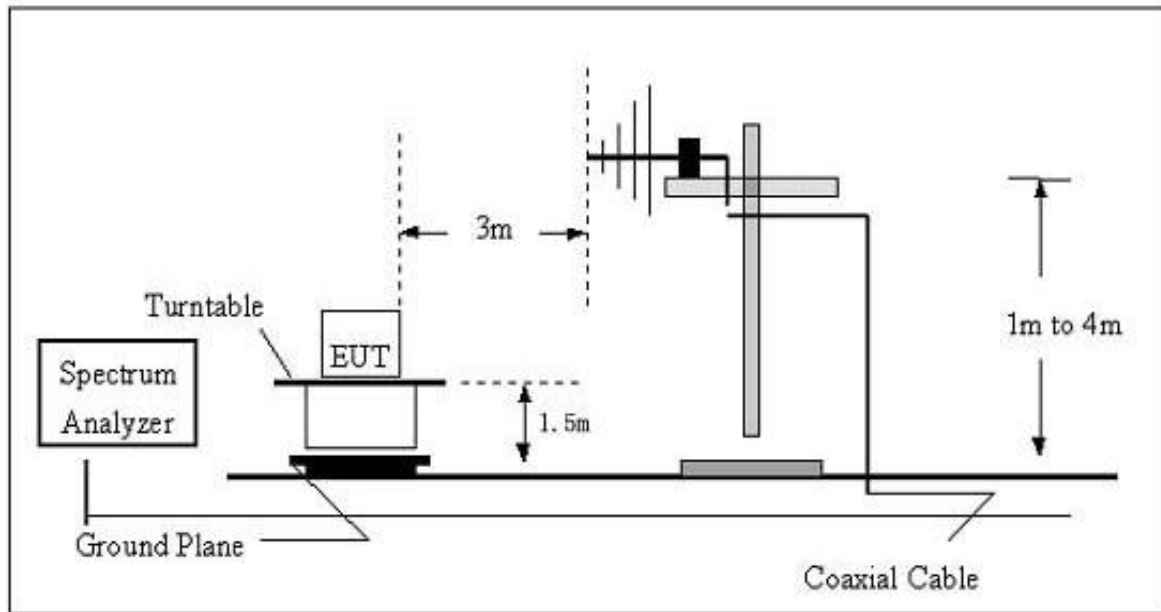

(B) Radiated Emission Test Set-Up Frequency Above 1GHz.

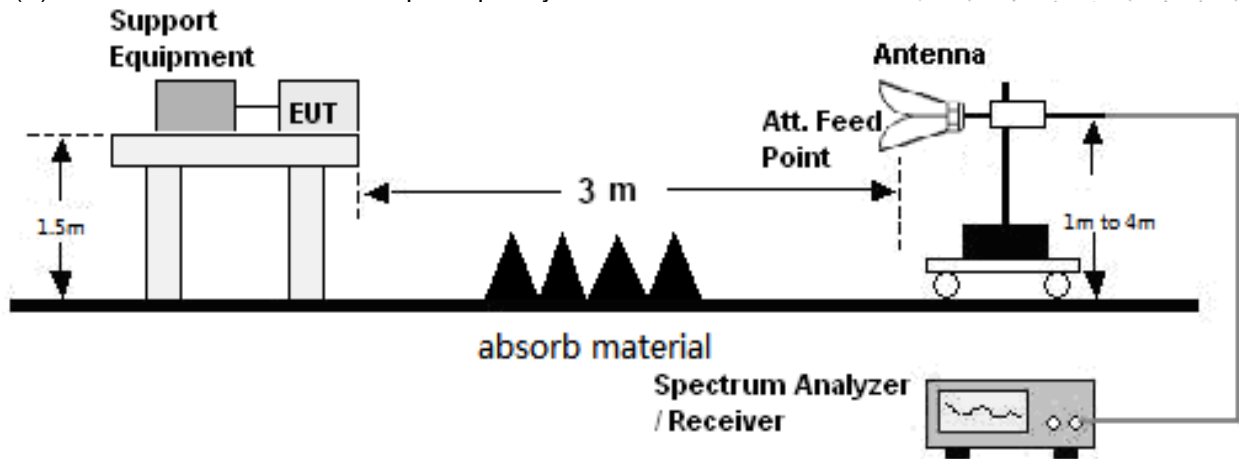

## 11.2 Limits

Frequency range	Maximum power, e.r.p. ( $\leq 1$ GHz) e.i.r.p. ( $> 1$ GHz)	Bandwidth
30 MHz to 47 MHz	-36 dBm	100 kHz/300KHz
47 MHz to 74 MHz	-54 dBm	100 kHz/300KHz
74 MHz to 87,5 MHz	-36 dBm	100 kHz/300KHz
87,5 MHz to 118 MHz	-54 dBm	100 kHz/300KHz
118 MHz to 174 MHz	-36 dBm	100 kHz/300KHz
174 MHz to 230 MHz	-54 dBm	100 kHz/300KHz
230 MHz to 470 MHz	-36 dBm	100 kHz/300KHz
470 MHz to 862 MHz	-54 dBm	100 kHz/300KHz
862 MHz to 1 GHz	-36 dBm	100 kHz/300KHz
1 GHz to 5.15 GHz	-30 dBm	1 MHz/3MHz
5.35 GHz to 5.47 GHz	-30 dBm	1 MHz/3MHz
5.725 GHz to 26 GHz	-30 dBm	1 MHz/3MHz

## 11.3 Test Procedure

### 30MHz ~ 1GHz:

- The Product was placed on the nonconductive turntable 1.5m above the ground in a full anechoic chamber.
- Set the spectrum analyzer/receiver in Peak detector, Max Hold mode, and 120 kHz RBW. Record the maximum field strength of all the pre-scan process in the full band when the antenna is varied between 1~4 m in both horizontal and vertical, and the turntable is rotated from 0 to 360 degrees.
- For each frequency whose maximum record was higher or close to limit, measure its QP value: vary the antenna's height and rotate the turntable from 0 to 360 degrees to find the height and degree where Product radiated the maximum emission, then set the test frequency analyzer/receiver to QP Detector and specified bandwidth with Maximum Hold Mode, and record the maximum value.

### Above 1GHz:

- The Product was placed on the non-conductive turntable 1.5 m above the ground in a full anechoic chamber..
- Set the spectrum analyzer/receiver in Peak detector, Max Hold mode, and 1MHz RBW. Record the maximum field strength of all the pre-scan process in the full band when the antenna is varied in both horizontal and vertical, and the turntable is rotated from 0 to 360 degrees.
- For each frequency whose maximum record was higher or close to limit, measure its AV value: rotate the turntable from 0 to 360 degrees to find the degree where Product radiated the maximum emission, then set the test frequency analyzer/receiver to AV value and specified bandwidth with Maximum Hold Mode, and record the maximum value.

## 11.4 Test Results

All modes have been tested and reports show data in the worst mode  
Worst case at MIMO

Frequency	Receiver Reading	Turn table Angle	RX Antenna		Correct	Absolute Level	Result	
			Height	Polar	Factor		Limit	Margin
(MHz)	(dBm)	Degree	(m)	(H/V)	(dBm)	(dBm)	(dBm)	(dB)
802.11n20 low channel								
546.34	-55.54	293	1.1	H	-7.77	-63.31	-54	-9.31
546.34	-53.83	72	1.2	V	-7.77	-61.60	-54	-7.60
10400.00	-42.90	311	2.0	H	-0.38	-43.28	-30	-13.28
10400.00	-38.68	56	1.5	V	-0.38	-39.06	-30	-9.06
15600.00	-55.10	80	1.1	H	8.83	-46.27	-30	-16.27
15600.00	-61.05	105	1.2	V	8.83	-52.22	-30	-22.22
802.11n20 Mid channel								
546.34	-55.54	293	1.1	H	-7.77	-63.31	-54	-9.31
546.34	-53.83	72	1.2	V	-7.77	-61.60	-54	-7.60
10400.00	-42.90	311	2.0	H	-0.38	-43.28	-30	-13.28
10400.00	-38.68	56	1.5	V	-0.38	-39.06	-30	-9.06
15600.00	-55.10	80	1.1	H	8.83	-46.27	-30	-16.27
15600.00	-61.05	105	1.2	V	8.83	-52.22	-30	-22.22
802.11n20 high channel								
546.34	-54.96	187	1.0	H	-7.77	-62.73	-54	-8.73
546.34	-54.32	76	1.6	V	-7.77	-62.09	-54	-8.09
10480.00	-43.60	77	2.0	H	-0.32	-43.92	-30	-13.92
10480.00	-38.22	190	1.6	V	-0.32	-38.54	-30	-8.54
15720.00	-54.82	282	1.8	H	9.35	-45.47	-30	-15.47
15720.00	-60.73	80	1.2	V	9.35	-51.38	-30	-21.38



## 12. Transmitter Unwanted Emissions In The Out-Of-Band Domain

### 12.1 Block Diagram Of Test Setup

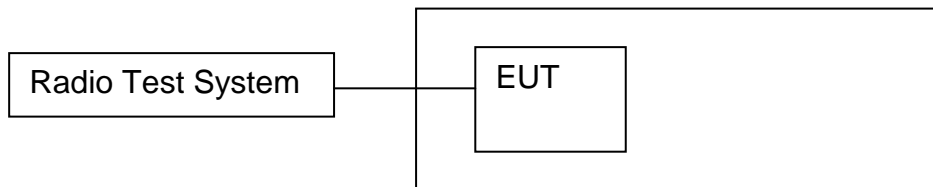

### 12.2 Limit

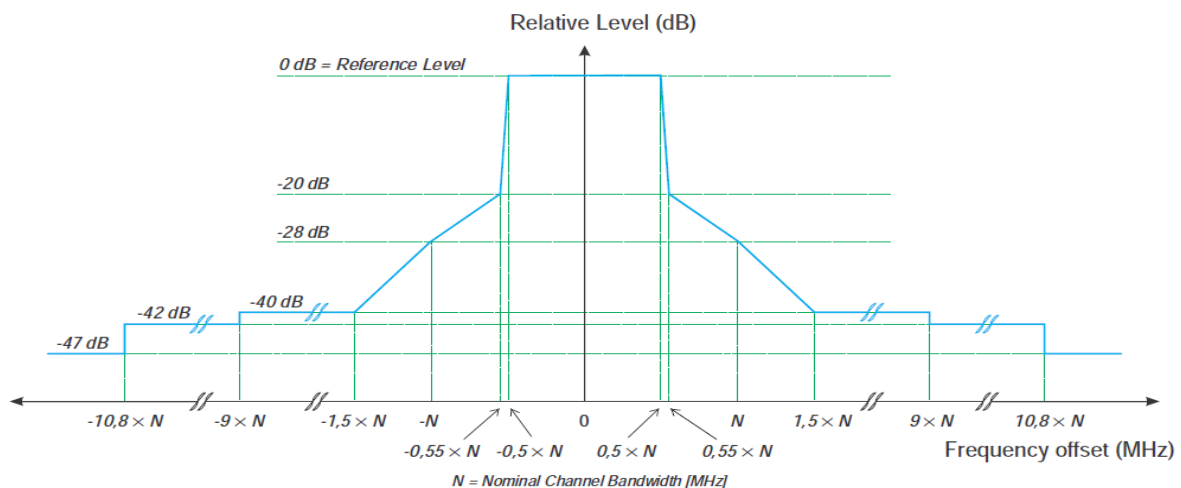

### 12.3 Test Procedure

The UUT shall be configured for continuous transmit mode (duty cycle equal to 100 %). If this is not possible, then option 2 shall be used.

#### Step 1: Determination of the reference average power level.

- Spectrum analyzer settings:
  - Resolution bandwidth: 1 MHz
  - Video bandwidth: 30 kHz
  - Detector mode: Peak
  - Trace mode: Video Average
  - Sweep Time: Coupled
  - Centre Frequency: Centre frequency of the channel being tested
  - Span: 2 × Nominal Channel Bandwidth

• Use the marker to find the highest average power level of the power envelope of the UUT. This level shall be used as the reference level for the relative measurements.

#### Step 2: Determination of the relative average power levels.

- Adjust the frequency range of the spectrum analyzer to allow the measurement to be performed within the sub-bands 5 150 MHz to 5 350 MHz and 5 470 MHz to 5 725 MHz. No other parameter of the spectrum analyzer should be changed.
- Compare the relative power envelope of the UUT with the limits defined in clause 4.2.4.2.2.

## 12.4 Test Result

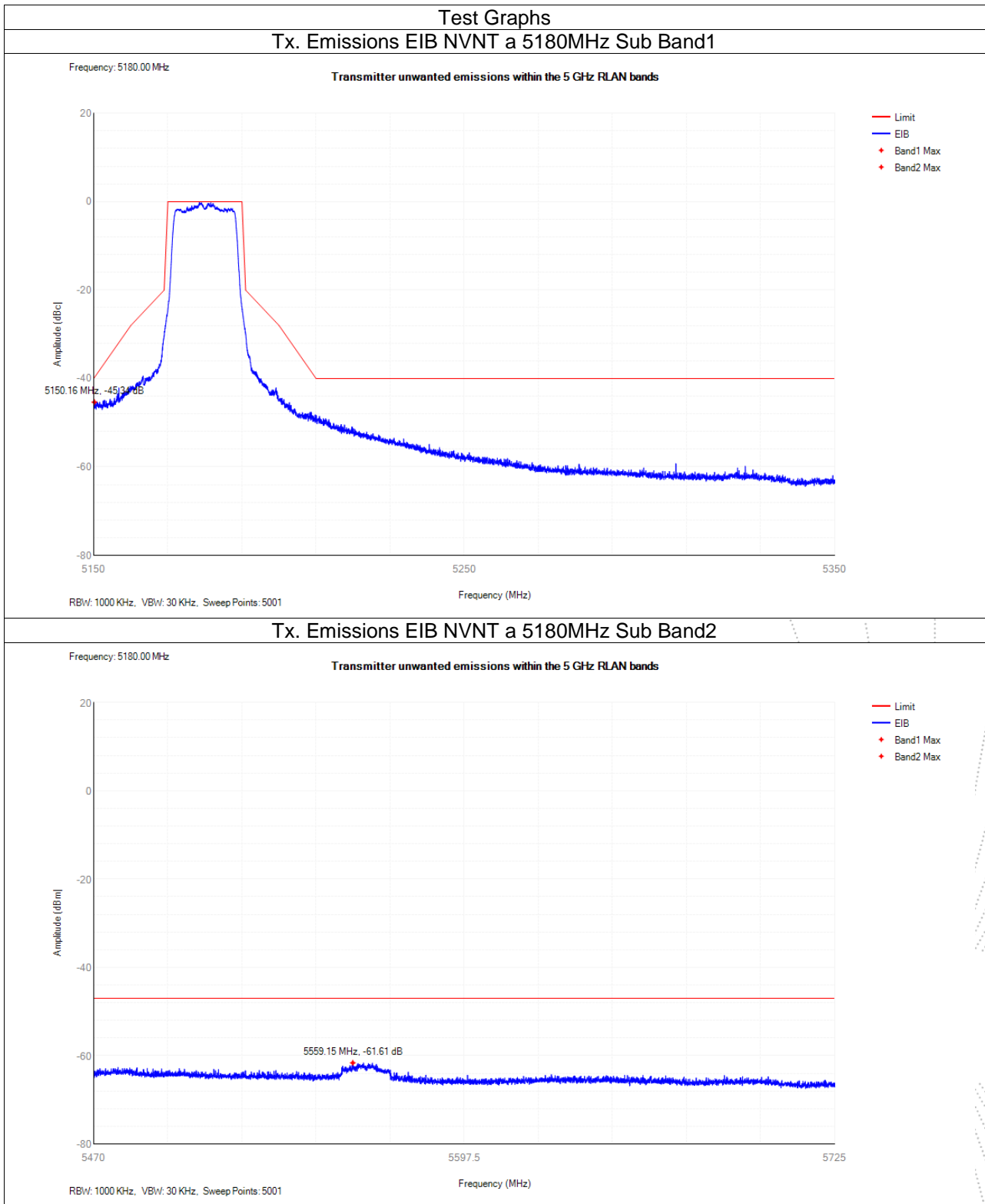

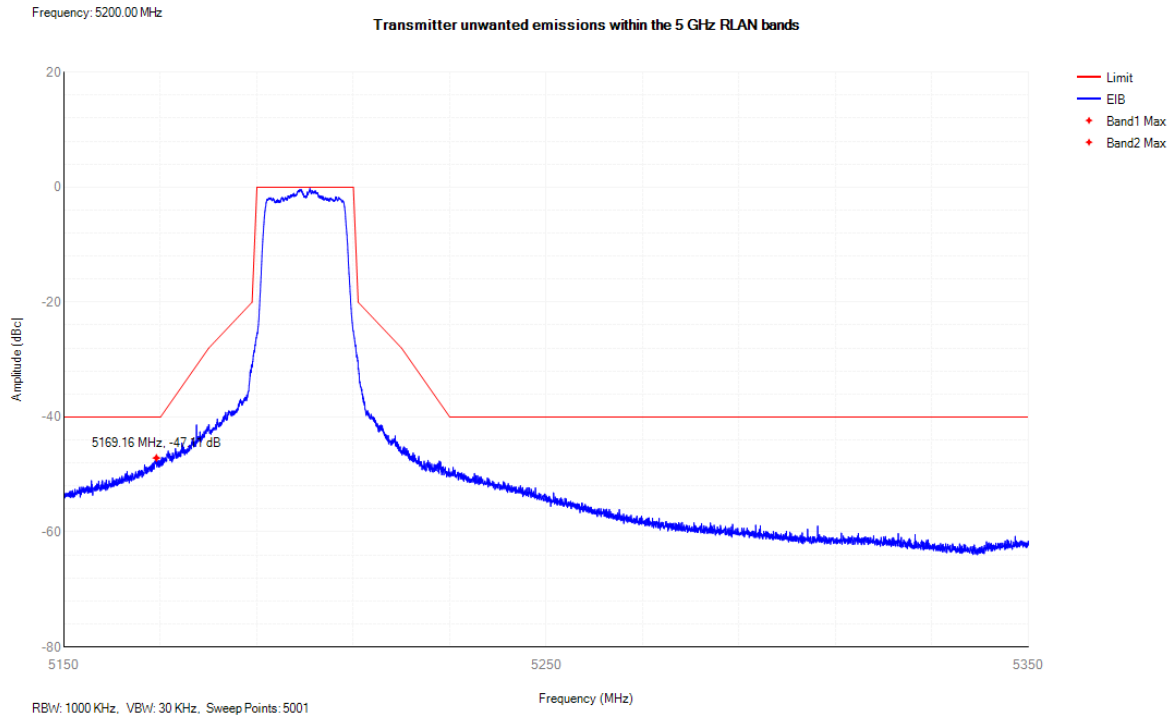
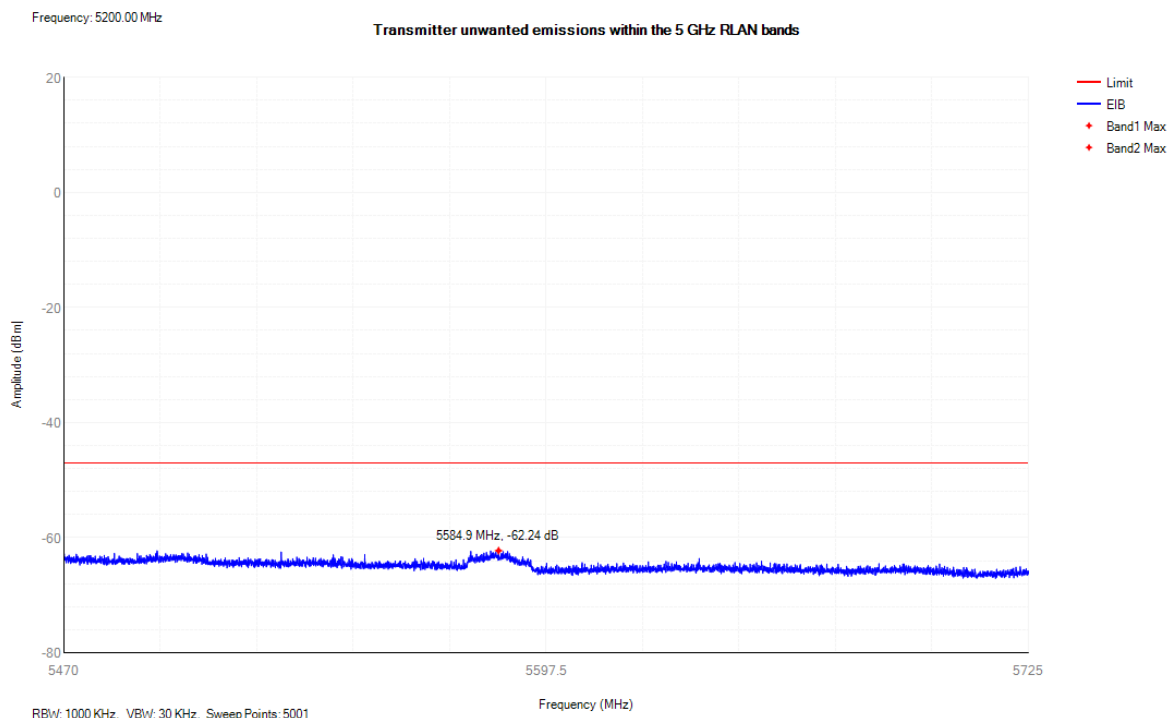
**Tx. Emissions EIB NVNT a 5200MHz Sub Band1**

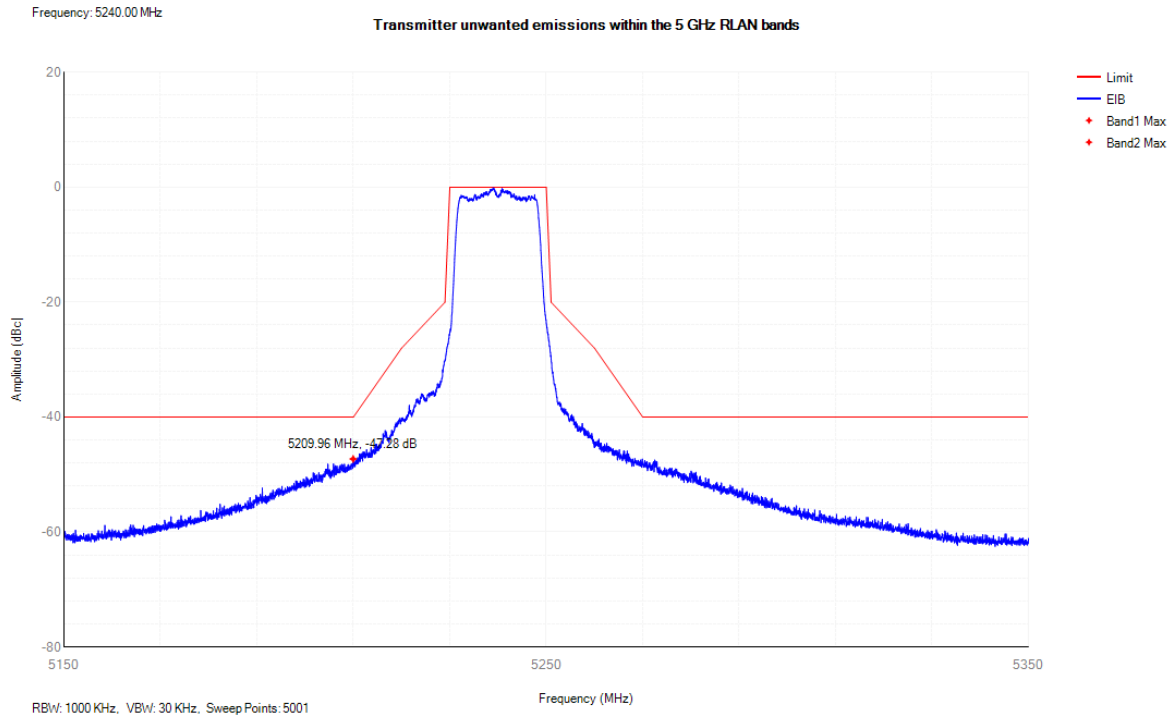
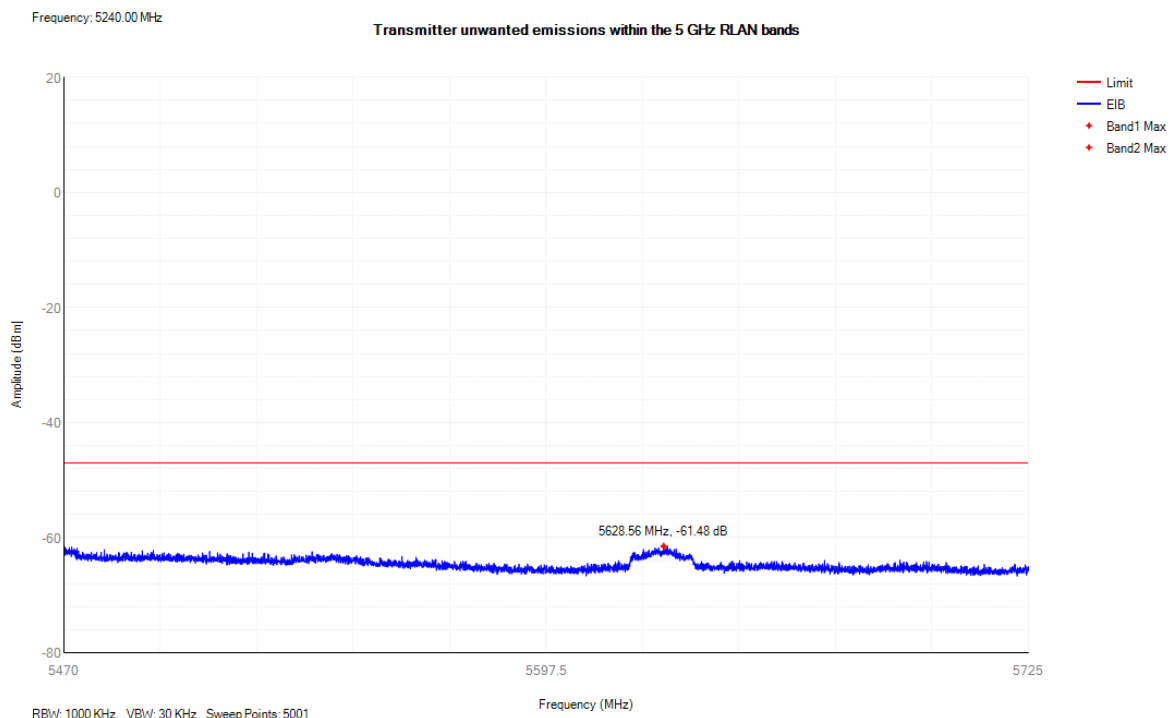
**Tx. Emissions EIB NVNT a 5200MHz Sub Band2**

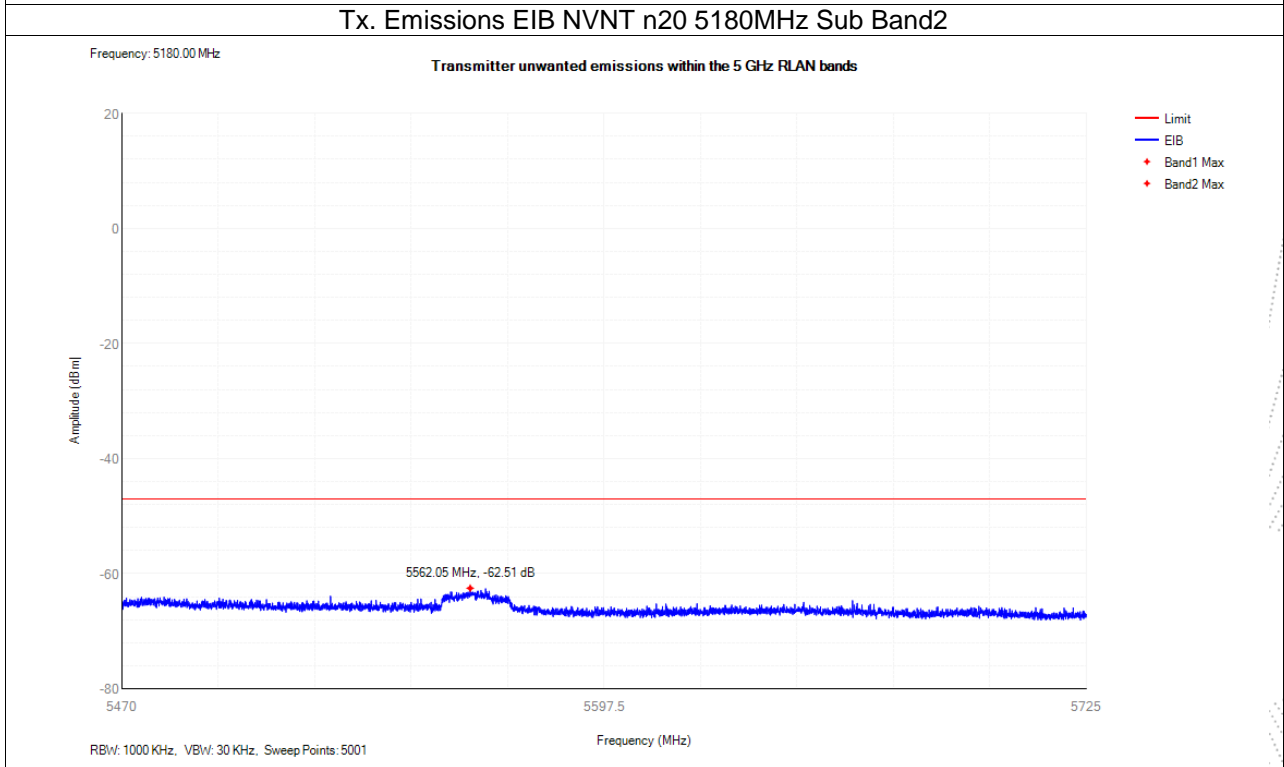
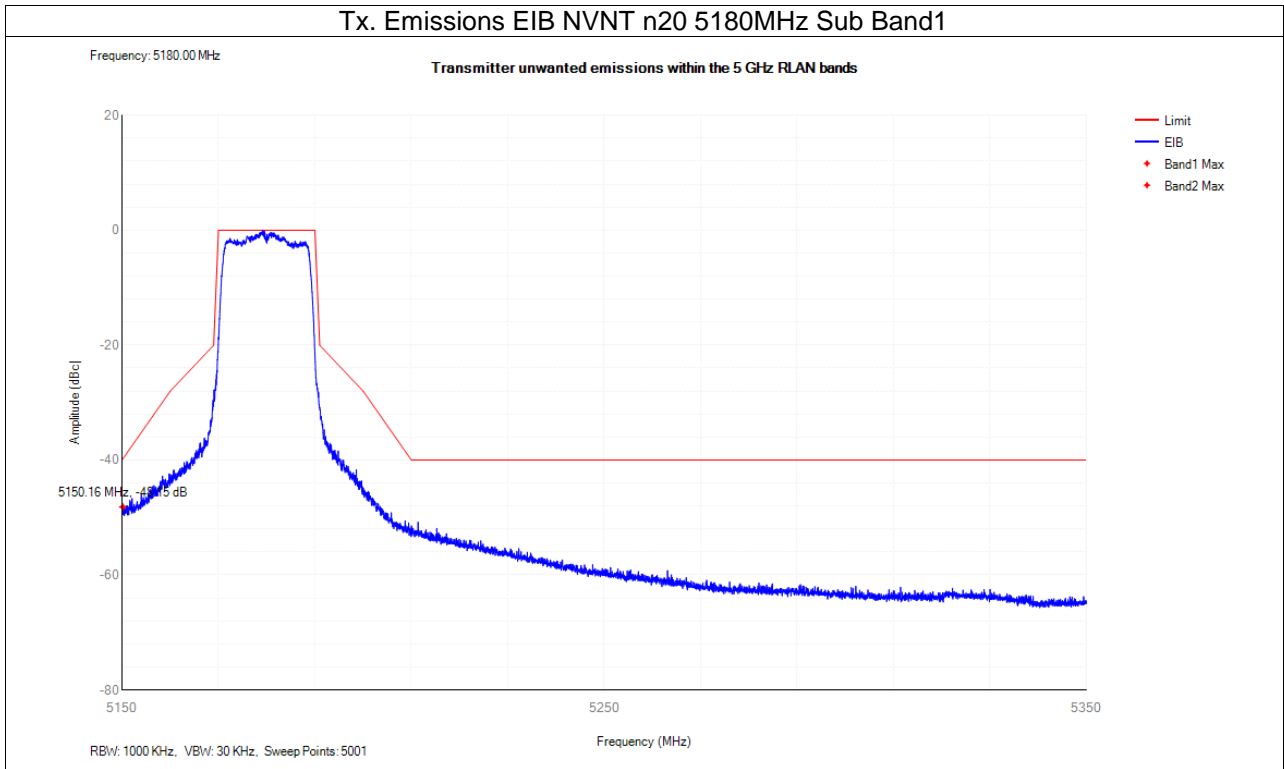
**Tx. Emissions EIB NVNT a 5240MHz Sub Band1**

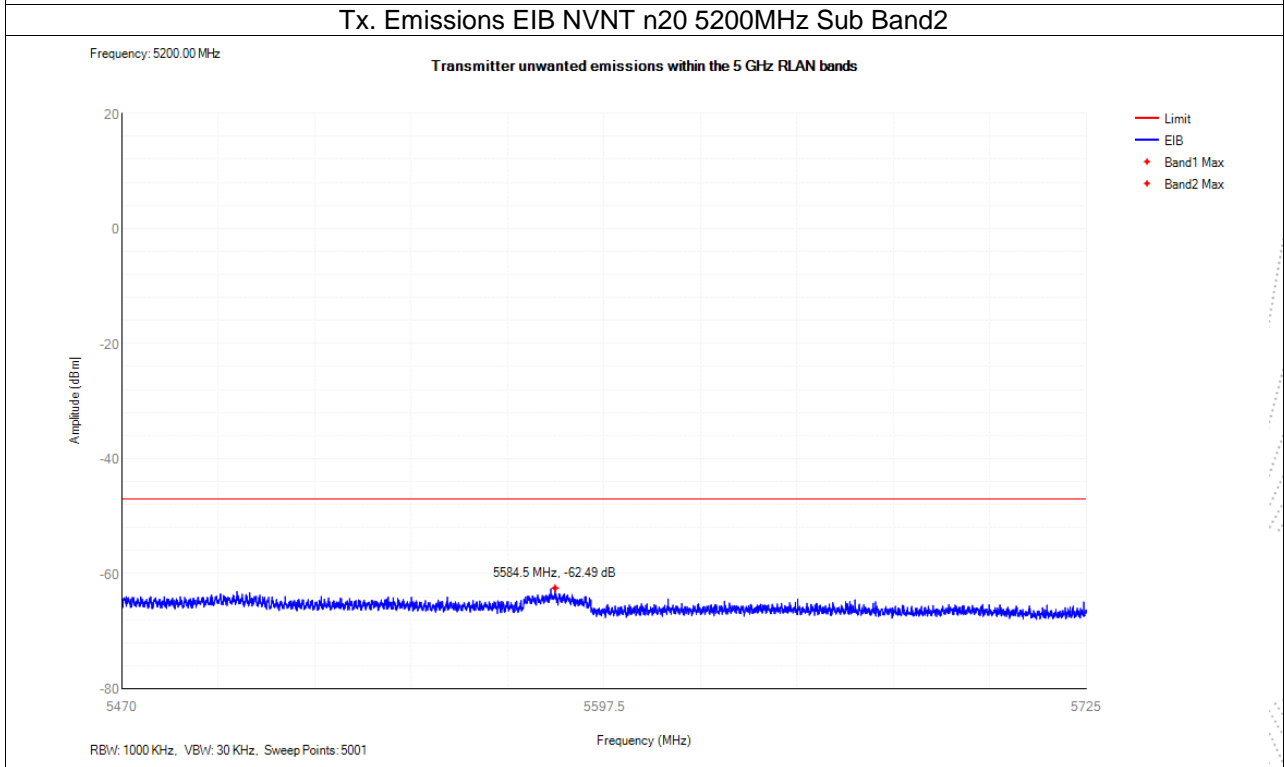
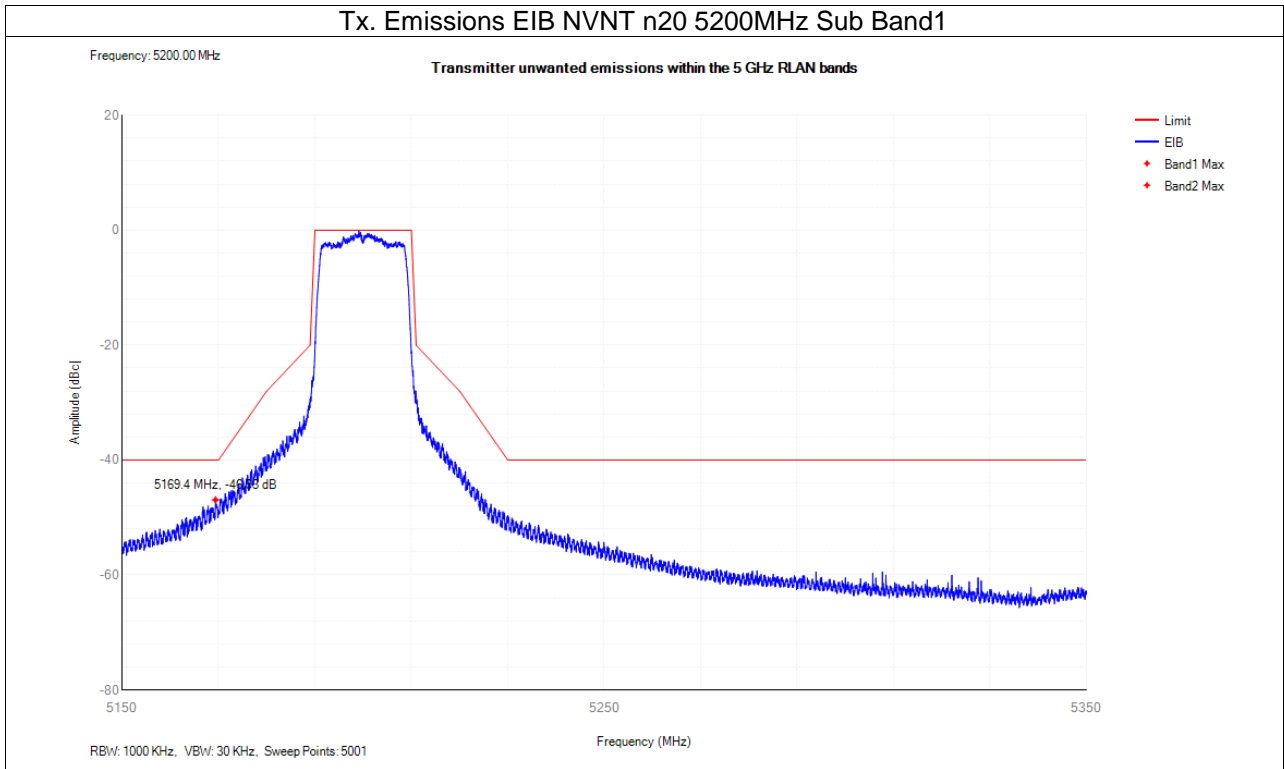
**Tx. Emissions EIB NVNT a 5240MHz Sub Band2**

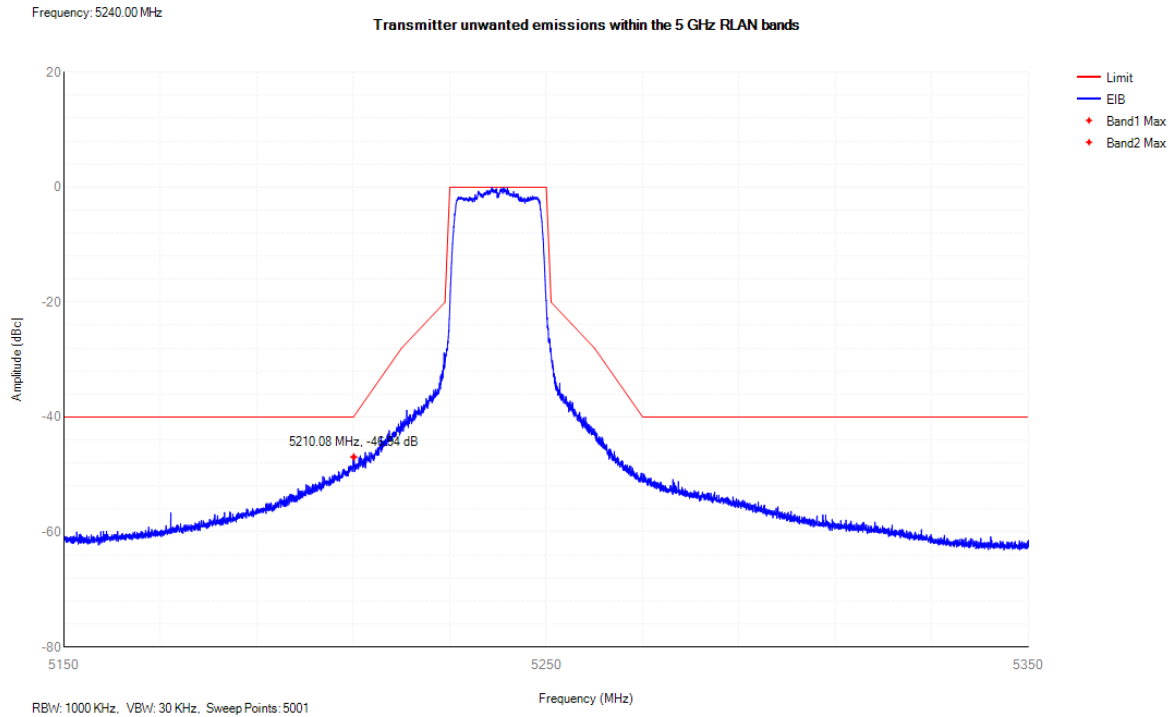
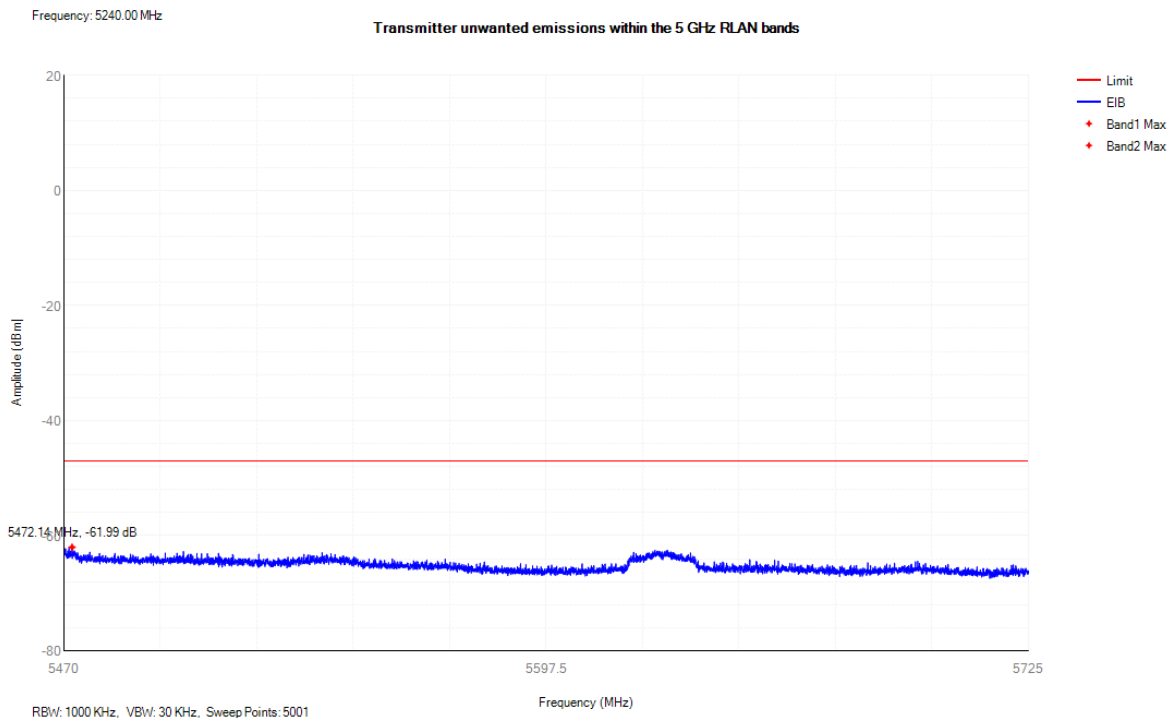

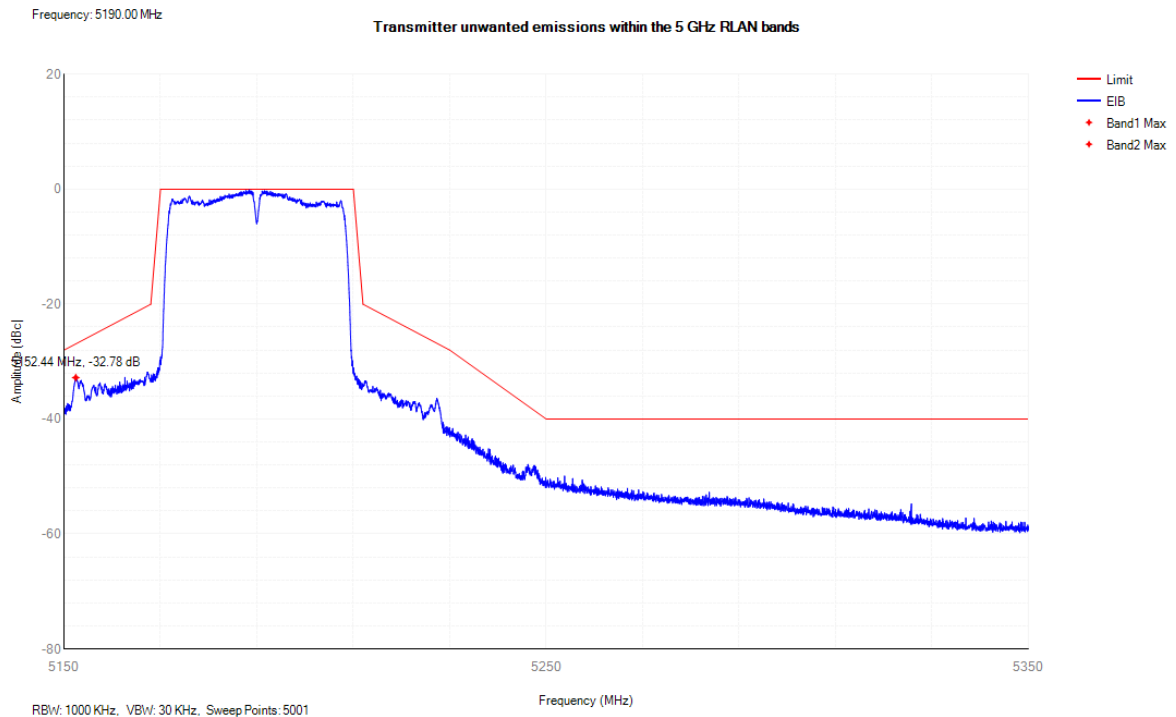
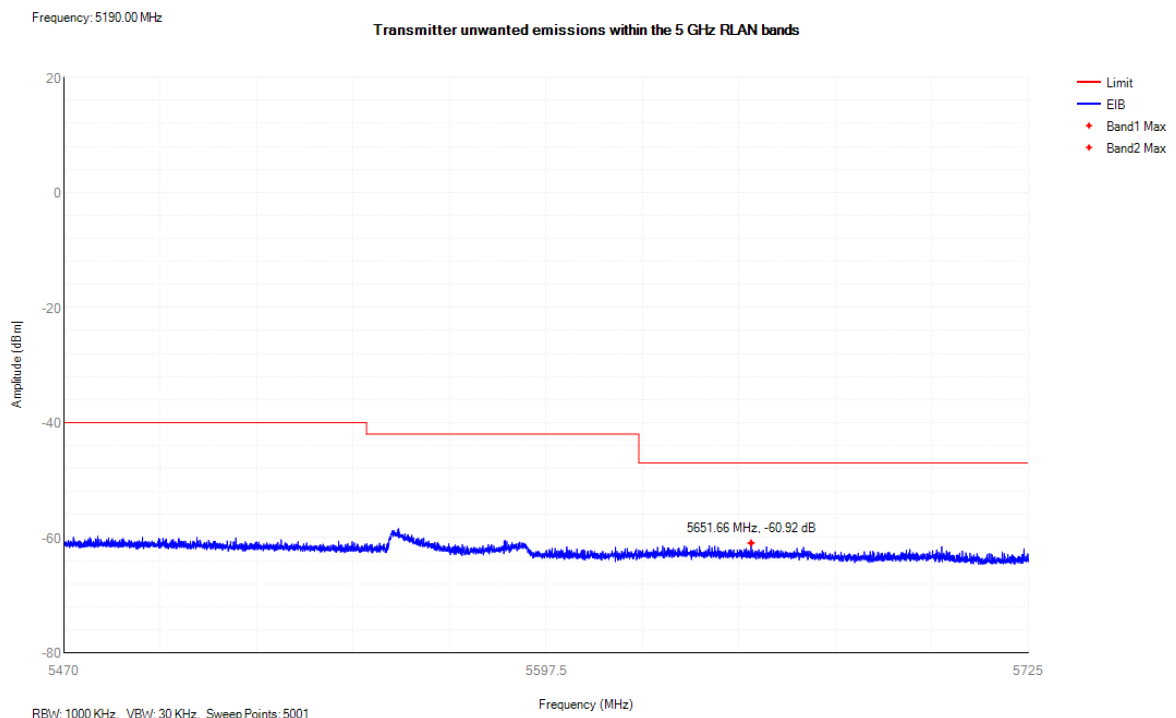

**Tx. Emissions EIB NVNT n20 5240MHz Sub Band1**

**Tx. Emissions EIB NVNT n20 5240MHz Sub Band2**

**Tx. Emissions EIB NVNT n40 5190MHz Sub Band1**

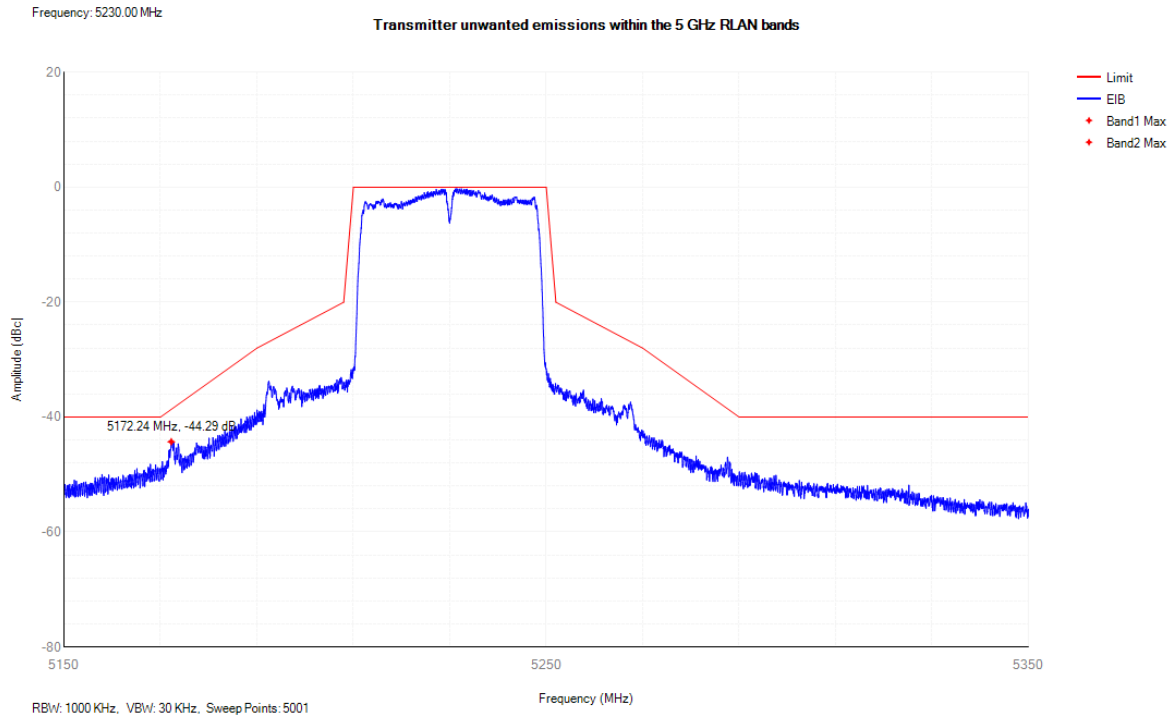
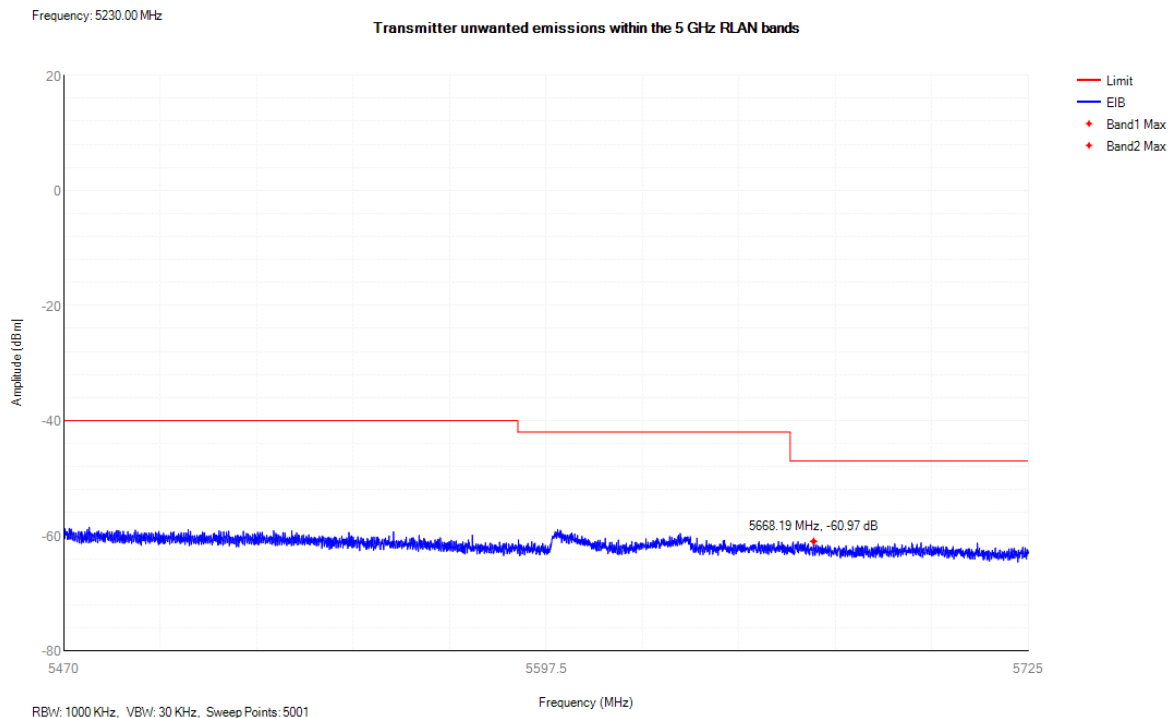
**Tx. Emissions EIB NVNT n40 5190MHz Sub Band2**

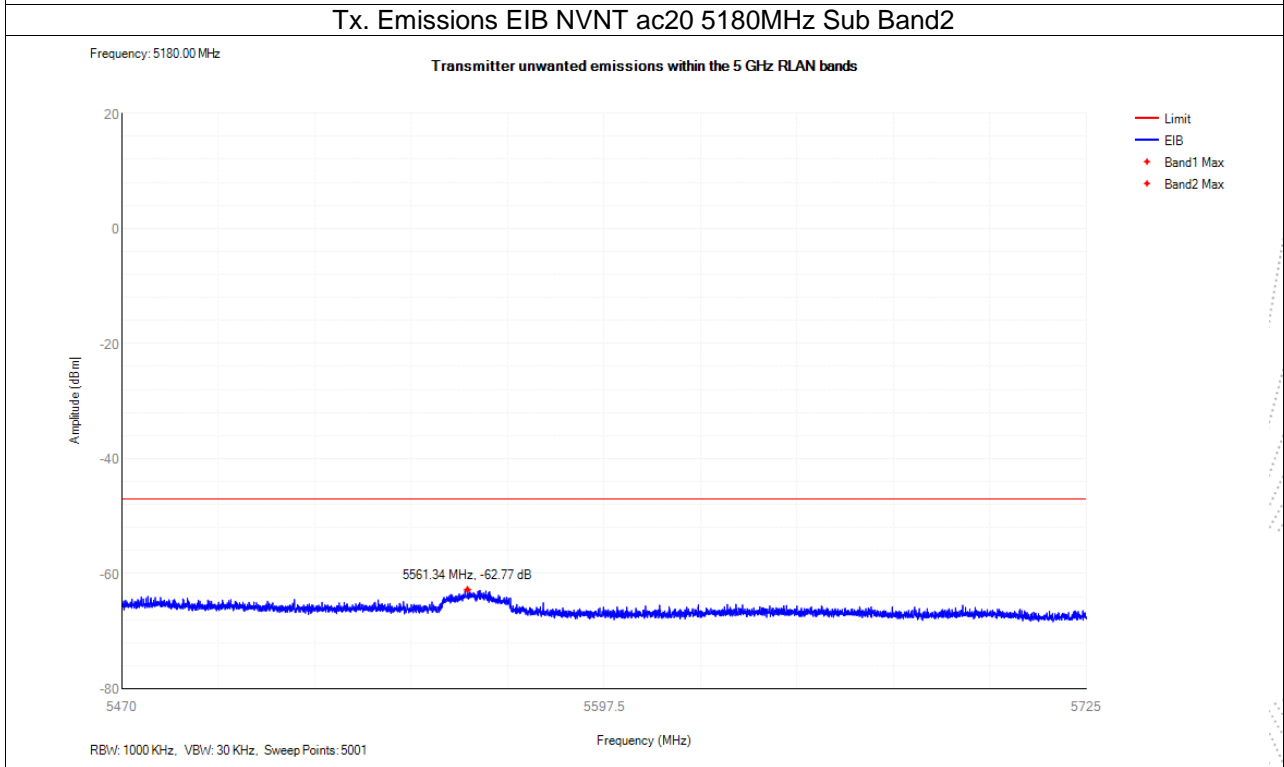
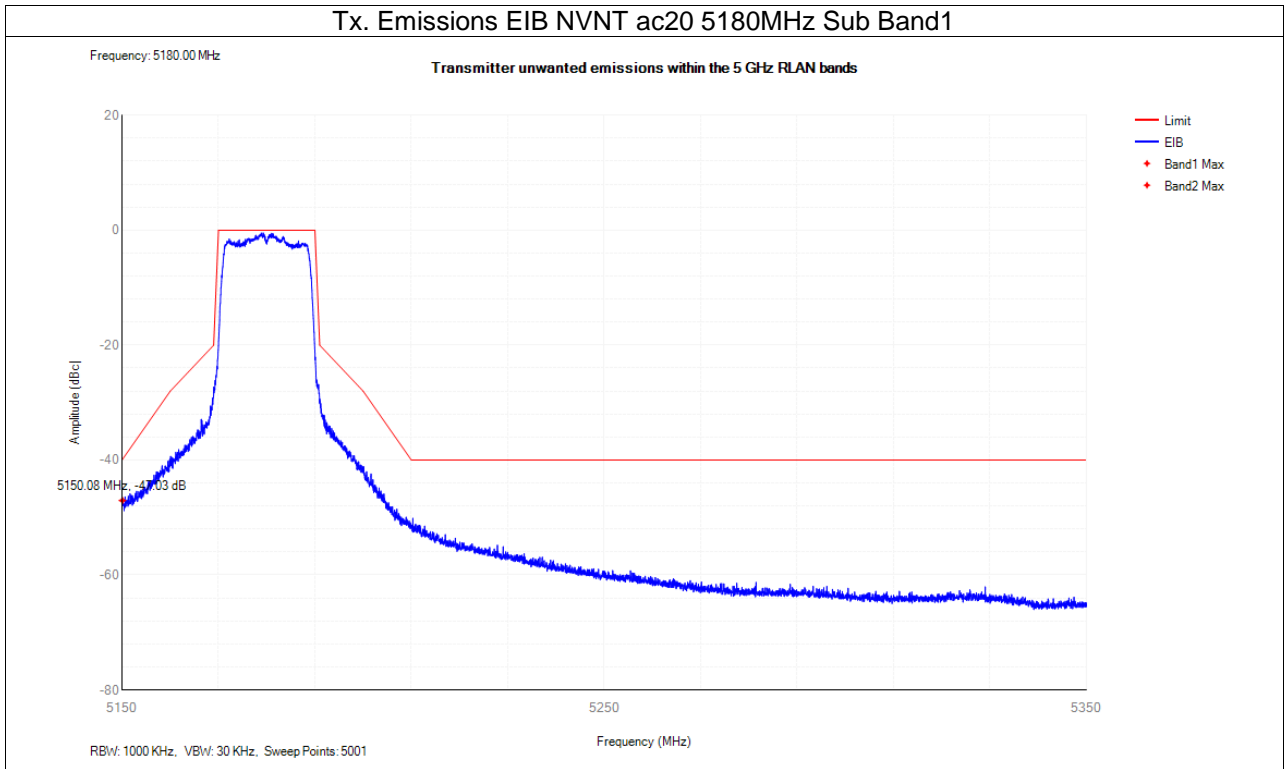

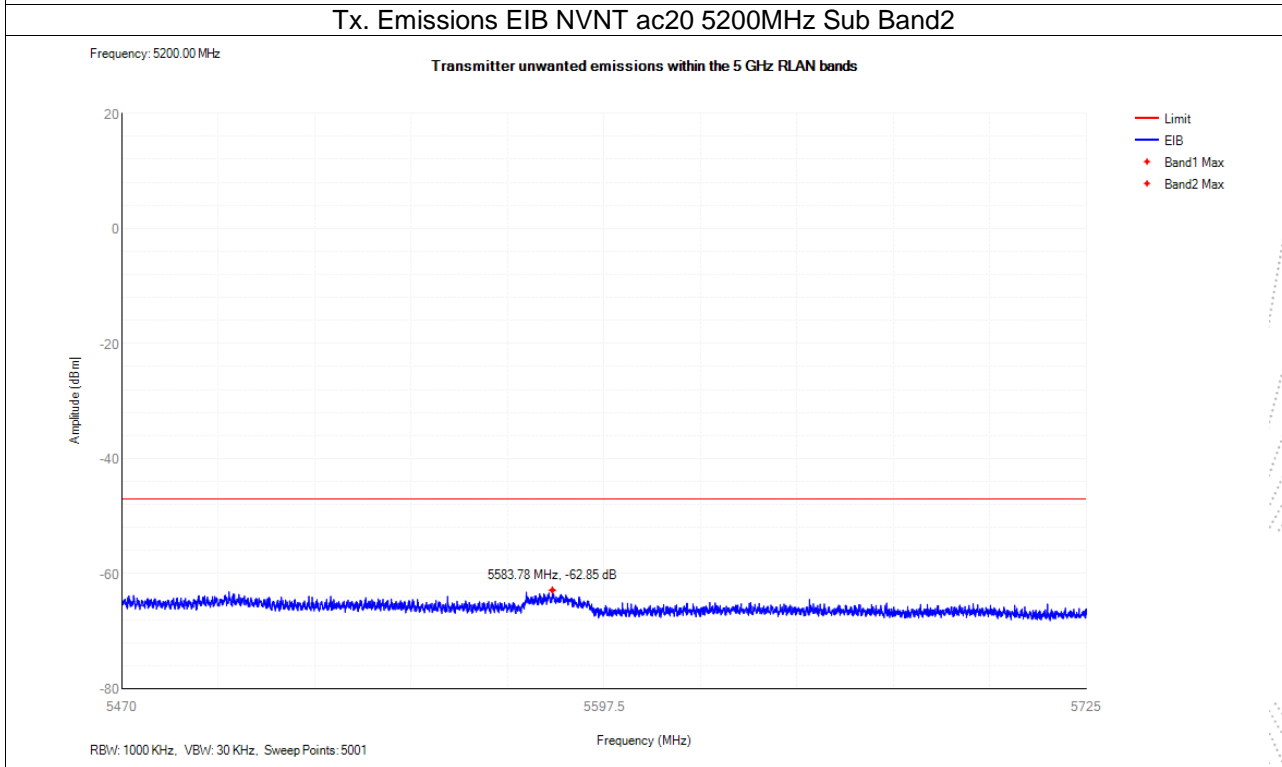
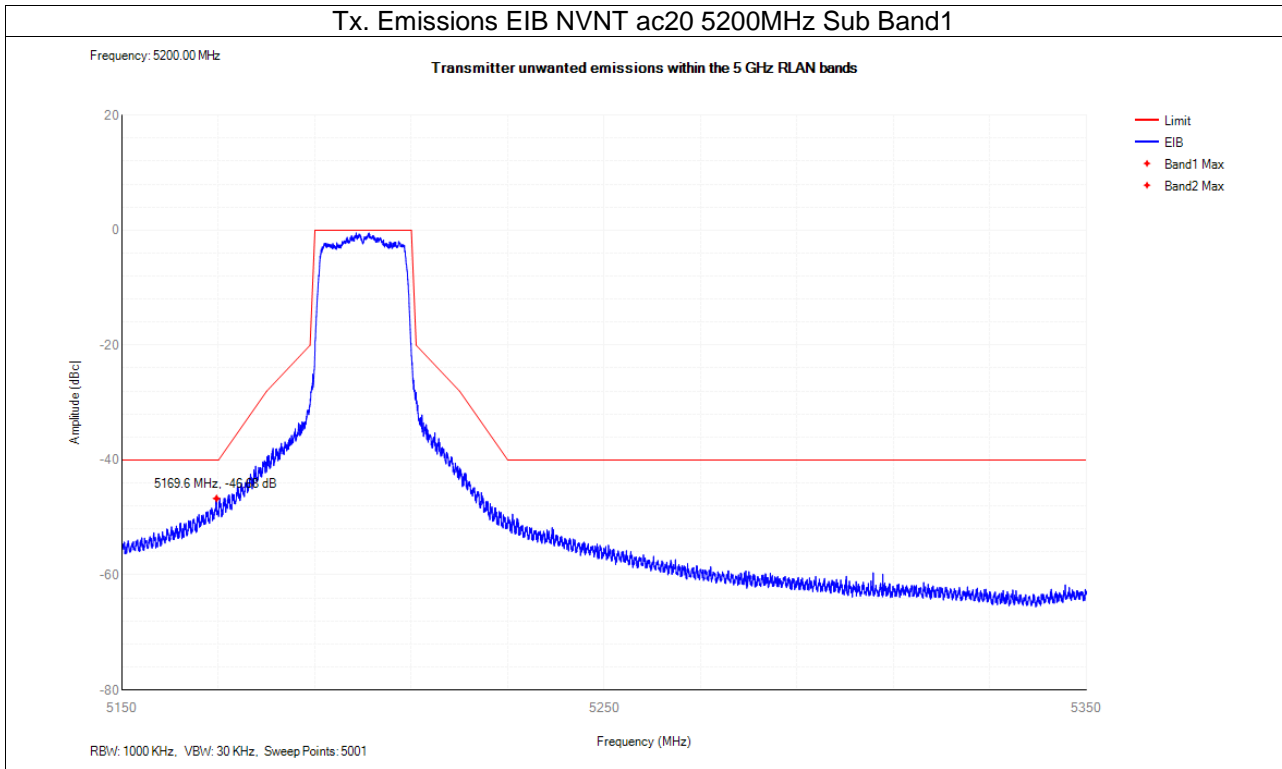
**Tx. Emissions EIB NVNT n40 5230MHz Sub Band1**

**Tx. Emissions EIB NVNT n40 5230MHz Sub Band2**

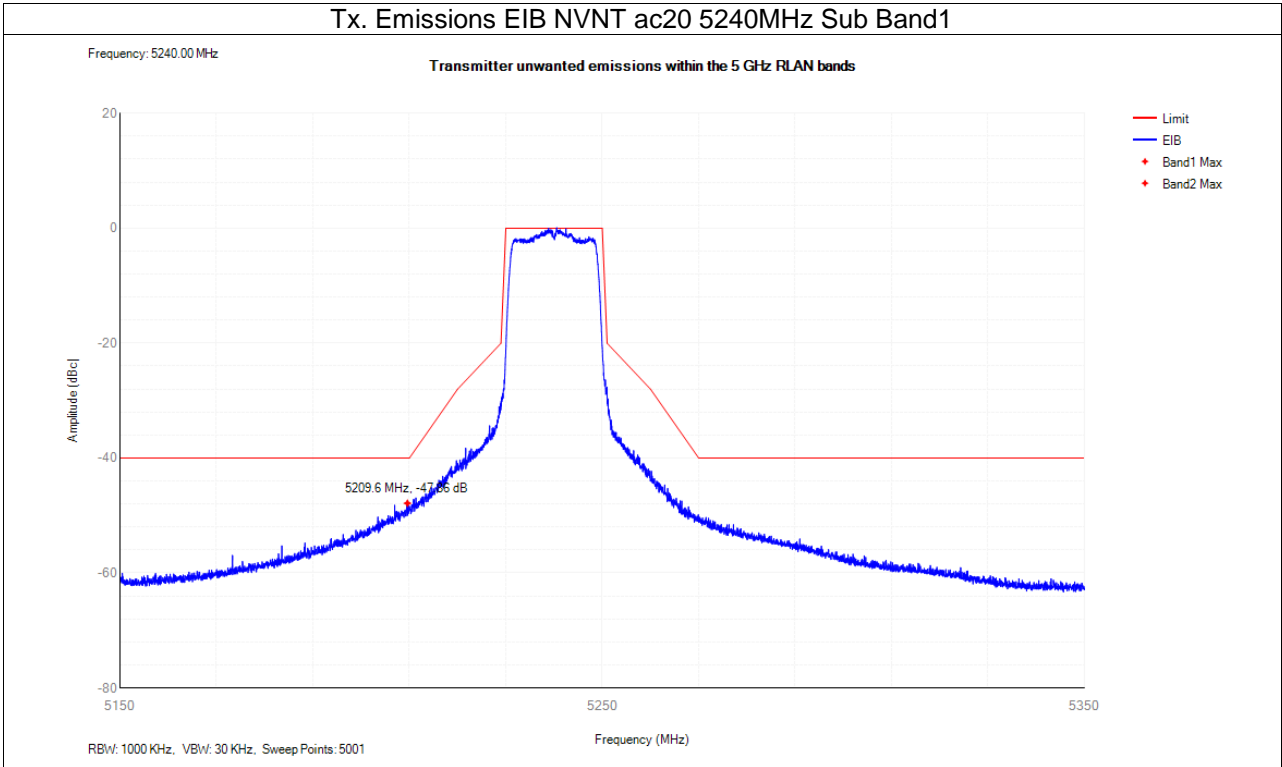
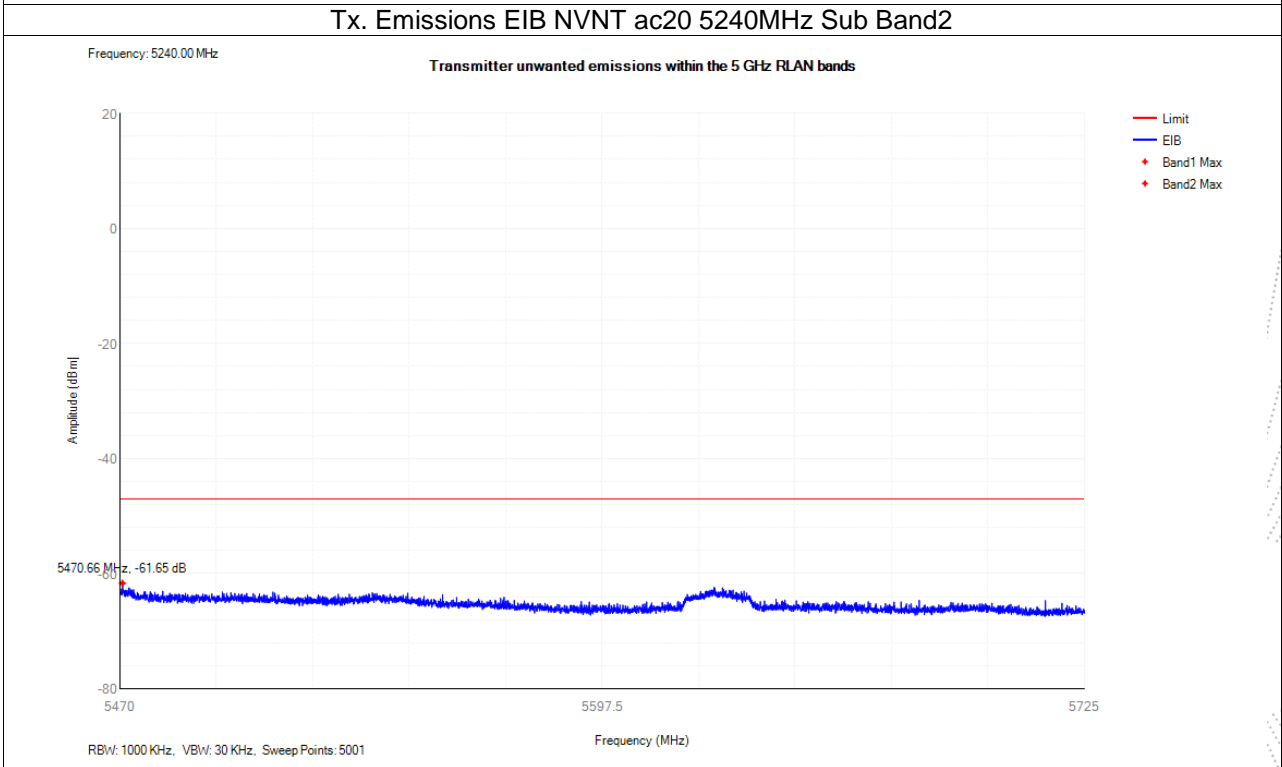

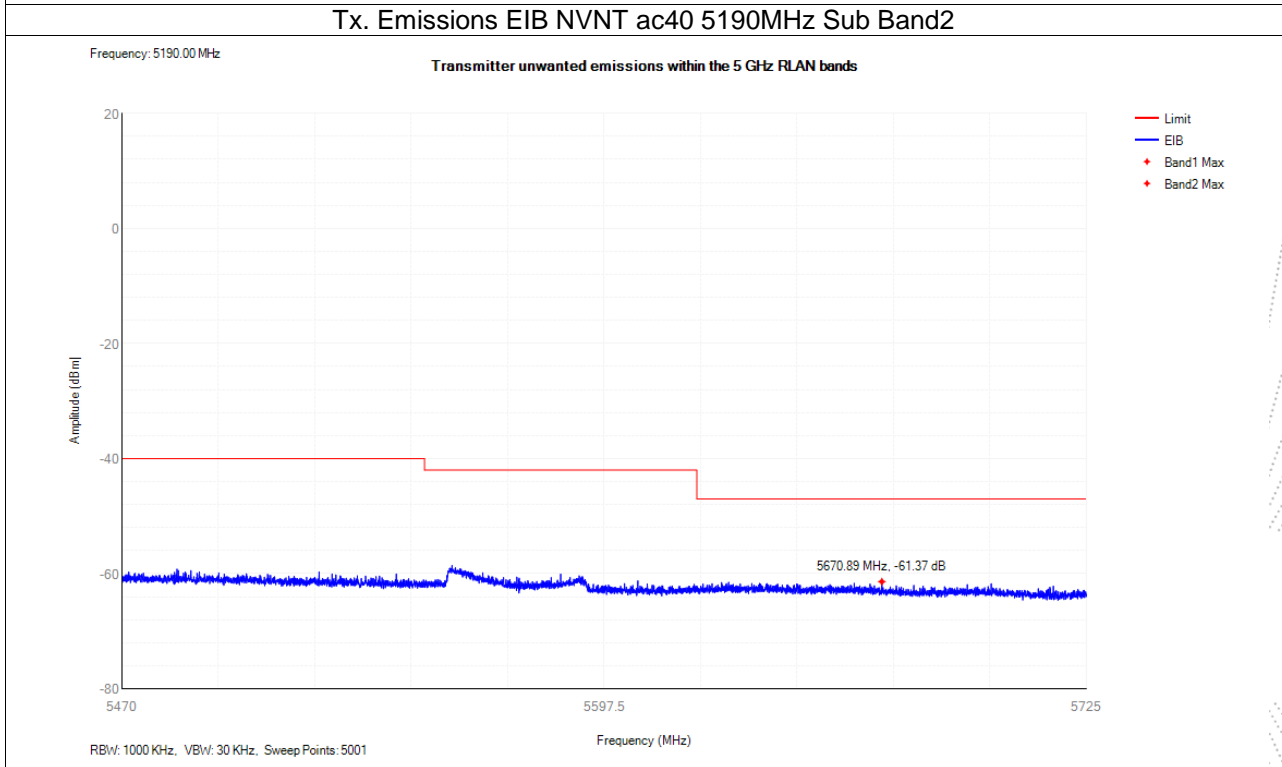
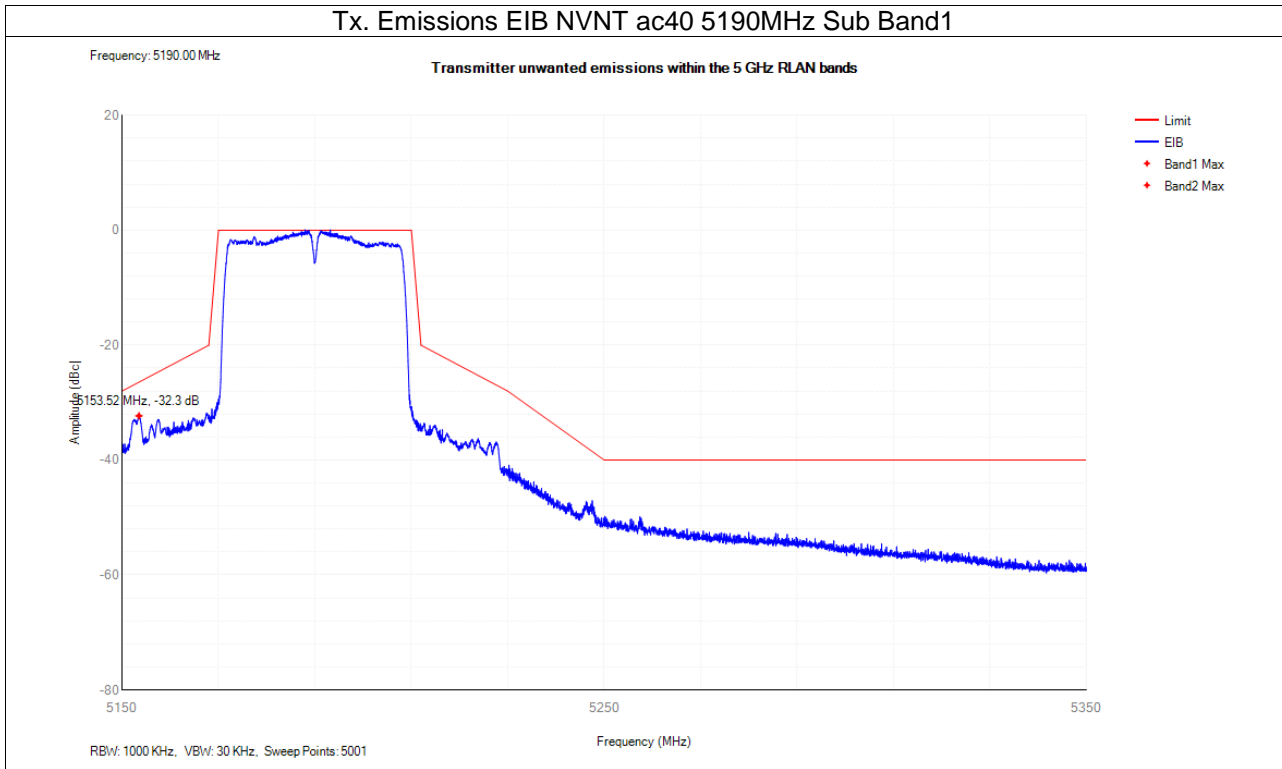

**Tx. Emissions EIB NVNT ac20 5240MHz Sub Band1**

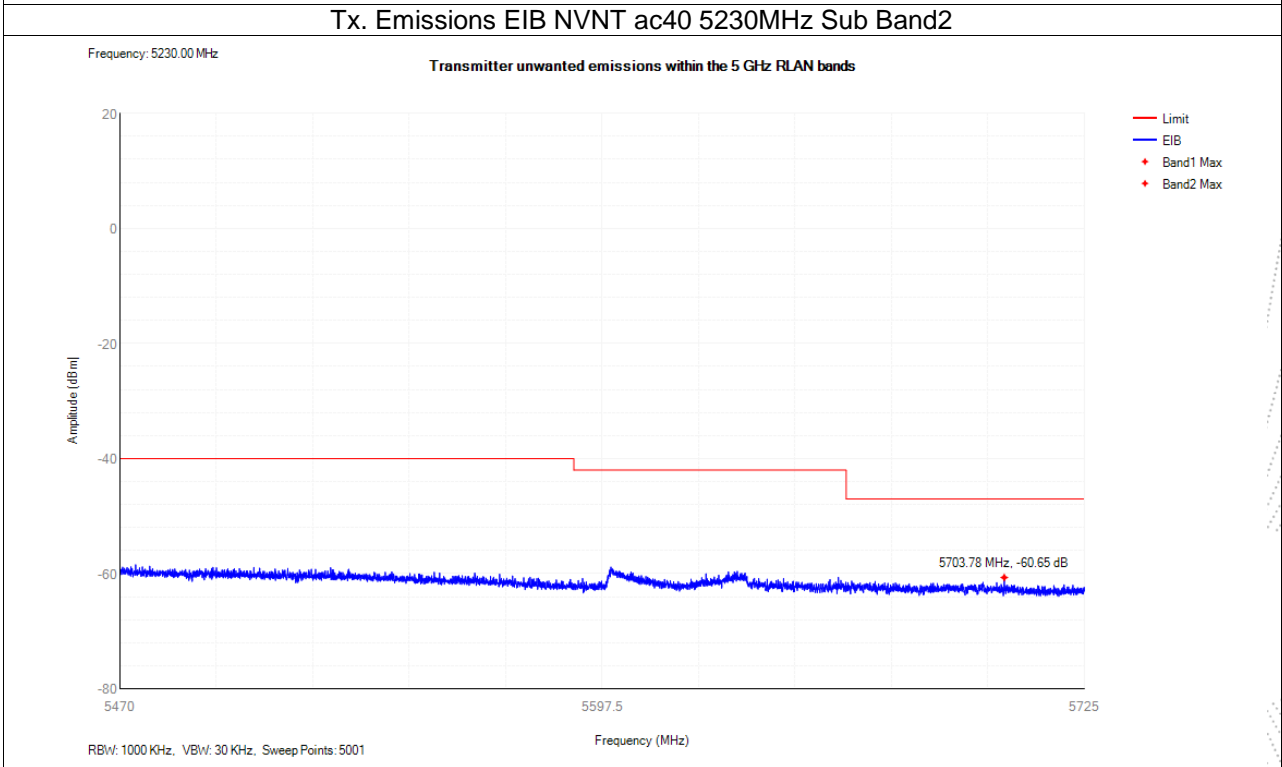
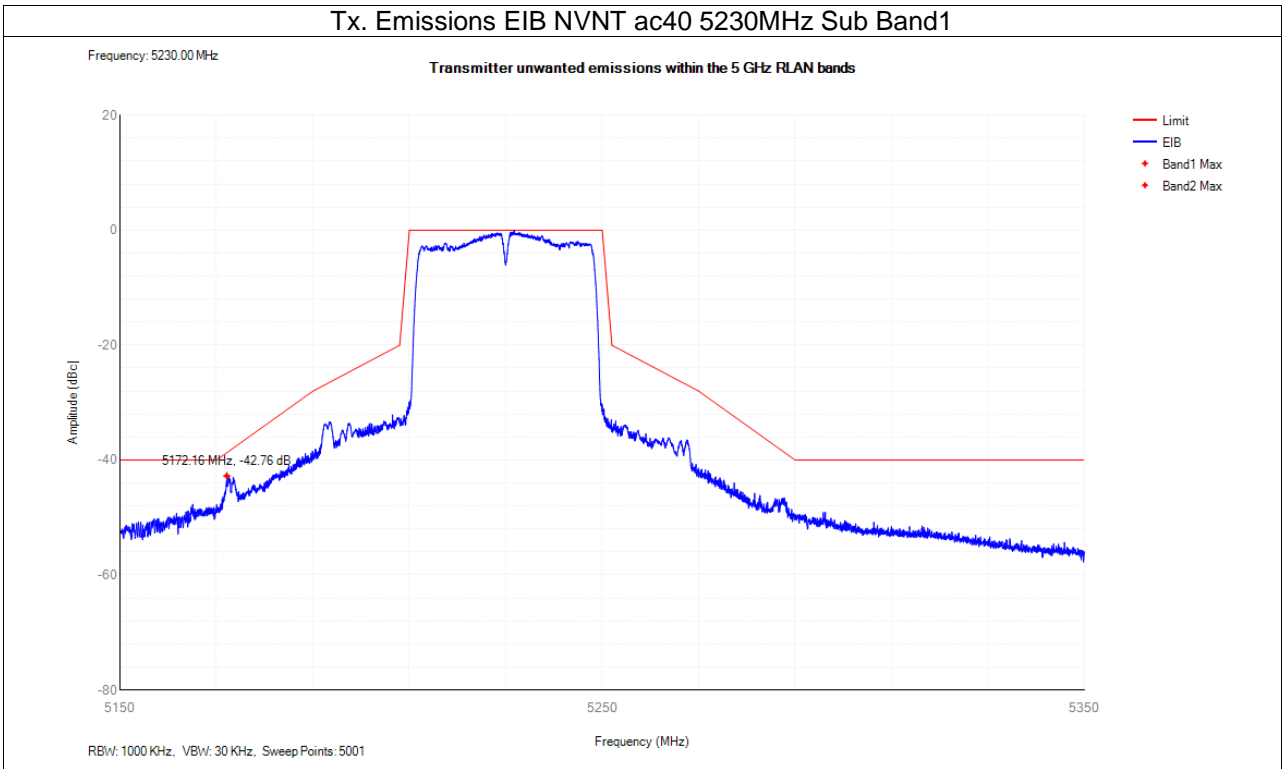
**Tx. Emissions EIB NVNT ac20 5240MHz Sub Band2**



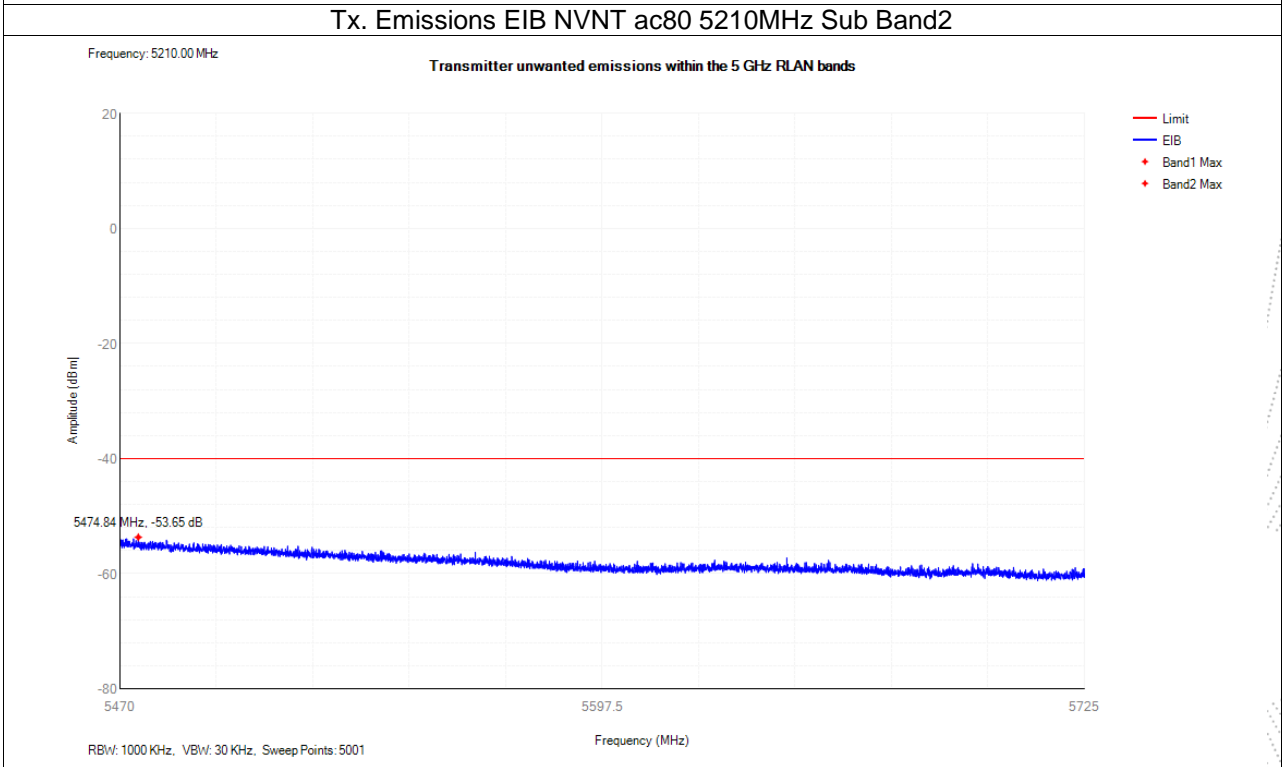
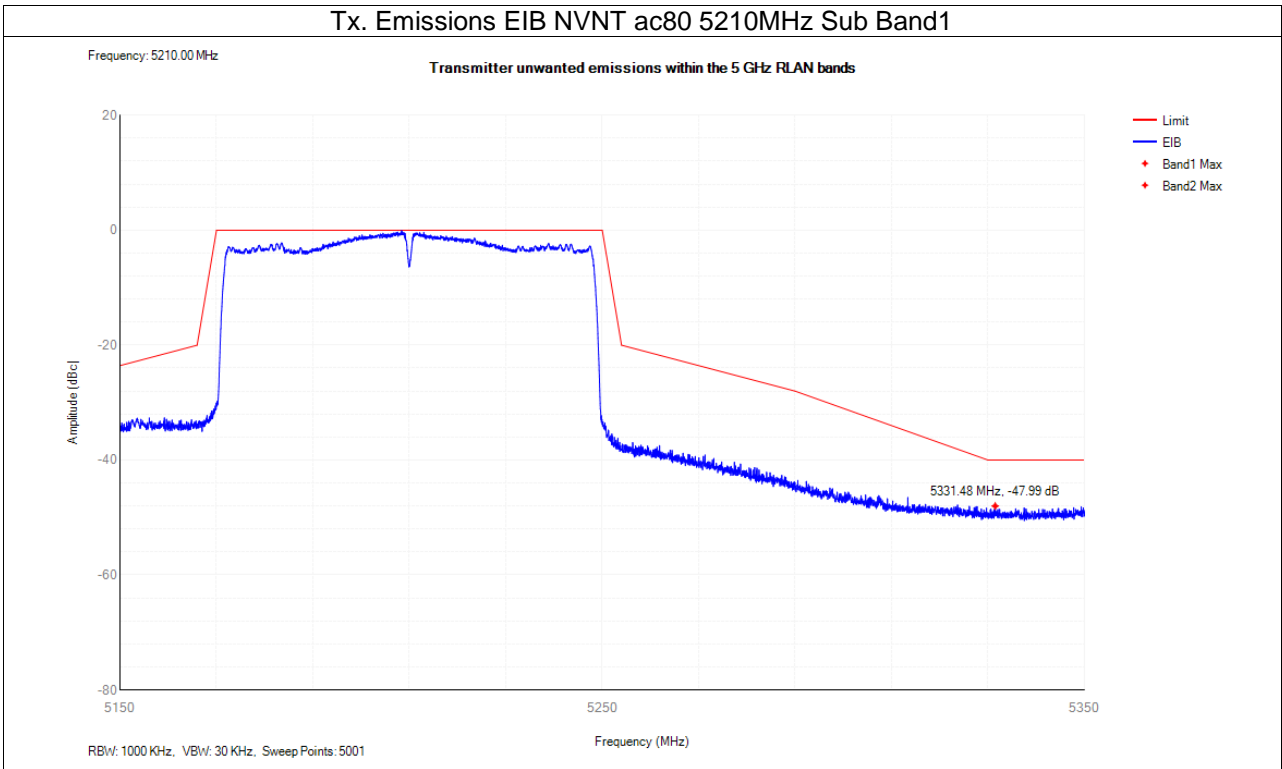



### 13. Receiver Spurious Emissions

#### 13.1 Block Diagram Of Test Setup

(A) Radiated Emission Test Set-Up Frequency Below 1GHz.

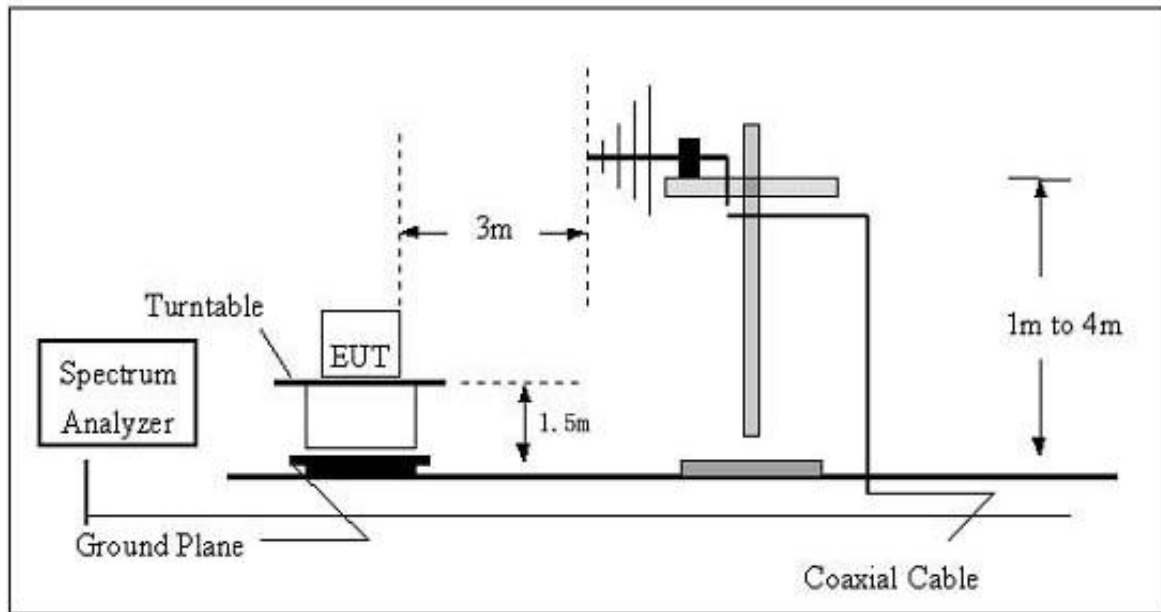

(B) Radiated Emission Test Set-Up Frequency Above 1GHz.

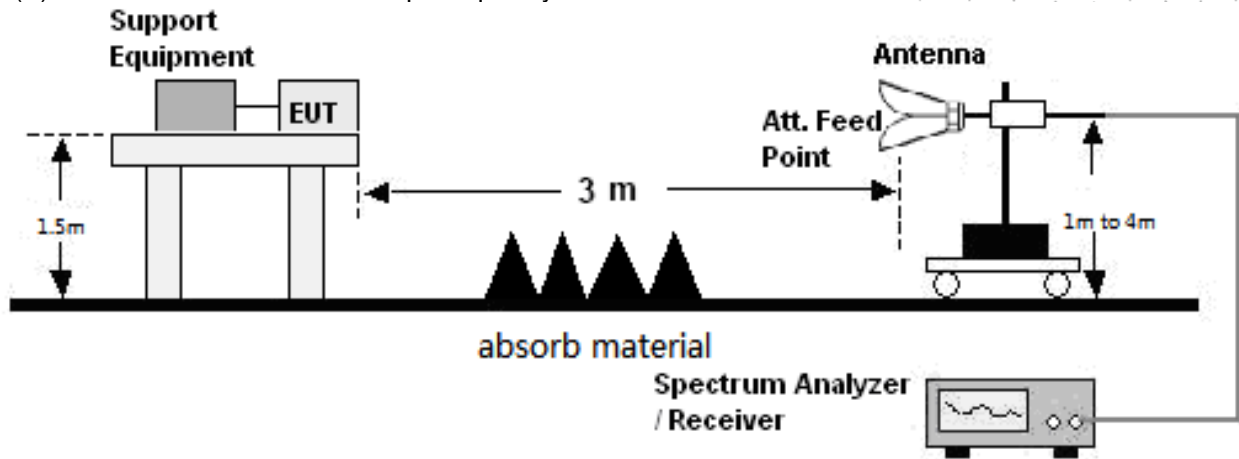

#### 13.2 Limits

Frequency(MHz)	Limit
30-1000	-57dBm
1000-12750	-47dBm



### 13.3 Test Procedure

**30MHz ~ 1GHz:**

- a. The Product was placed on the nonconductive turntable 1.5m above the ground in a full anechoic chamber.
- b. Set the spectrum analyzer/receiver in Peak detector, Max Hold mode, and 120 kHz RBW. Record the maximum field strength of all the pre-scan process in the full band when the antenna is varied between 1~4 m in both horizontal and vertical, and the turntable is rotated from 0 to 360 degrees.
- c. For each frequency whose maximum record was higher or close to limit, measure its QP value: vary the antenna's height and rotate the turntable from 0 to 360 degrees to find the height and degree where Product radiated the maximum emission, then set the test frequency analyzer/receiver to QP Detector and specified bandwidth with Maximum Hold Mode, and record the maximum value.

**Above 1GHz:**

- a. The Product was placed on the non-conductive turntable 1.5 m above the ground in a full anechoic chamber..
- b. Set the spectrum analyzer/receiver in Peak detector, Max Hold mode, and 1MHz RBW. Record the maximum field strength of all the pre-scan process in the full band when the antenna is varied in both horizontal and vertical, and the turntable is rotated from 0 to 360 degrees.
- c. For each frequency whose maximum record was higher or close to limit, measure its AV value: rotate the turntable from 0 to 360 degrees to find the degree where Product radiated the maximum emission, then set the test frequency analyzer/receiver to AV value and specified bandwidth with Maximum Hold Mode, and record the maximum value.

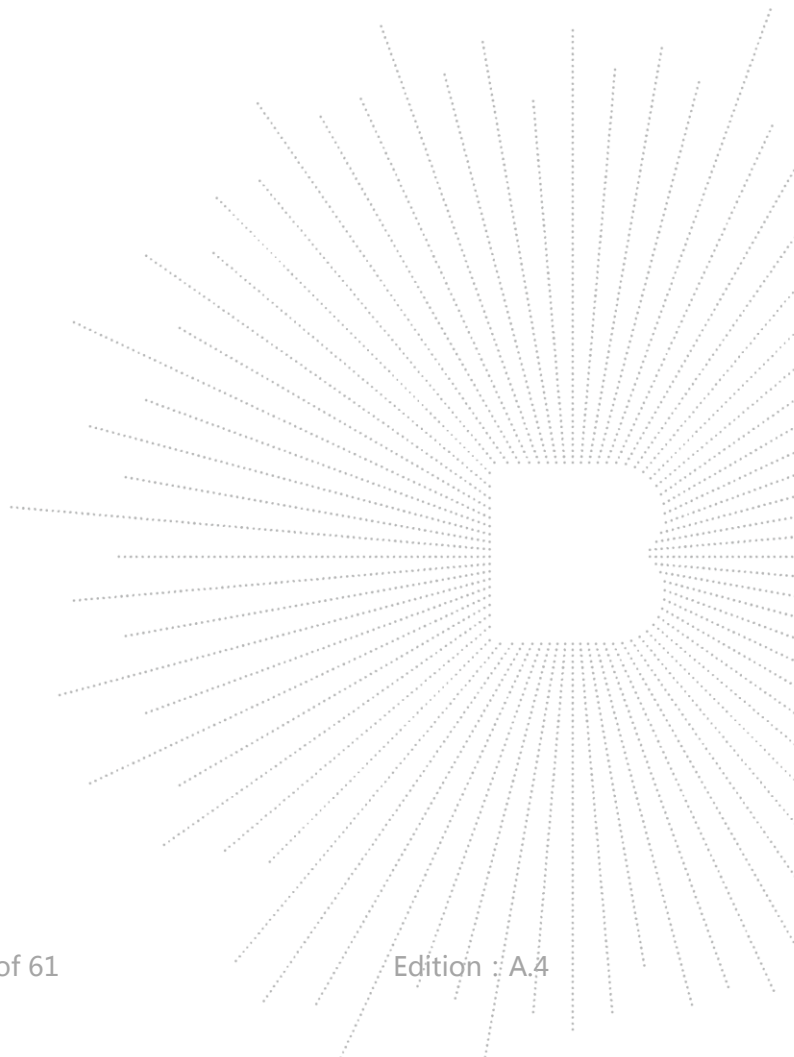

### 13.4 Test Results

All modes have been tested and reports show data in the worst mode  
Worst case at MIMO

Frequency	Receiver Reading	Turn table Angle	RX Antenna		Correct	Absolute Level	Result	
			Height	Polar	Factor		Limit	Margin
(MHz)	(dBm)	Degree	(m)	(H/V)	(dBm)	(dBm)	(dBm)	(dB)
802.11n20 low channel								
374.25	-54.23	96	1.3	H	-11.67	-65.90	-57.00	-8.90
374.25	-55.44	37	1.4	V	-11.67	-67.11	-57.00	-10.11
2490.52	-51.56	302	1.4	H	-6.80	-58.36	-47.00	-11.36
2490.52	-53.81	95	1.8	V	-6.80	-60.61	-47.00	-13.61
802.11n20 Mid channel								
374.25	-54.92	211	1.5	H	-11.67	-66.59	-57.00	-9.59
374.25	-56.15	39	1.4	V	-11.67	-67.82	-57.00	-10.82
2490.52	-51.19	112	1.5	H	-6.80	-57.99	-47.00	-10.99
2490.52	-54.57	129	1.2	V	-6.80	-61.37	-47.00	-14.37
802.11n20 high channel								
374.25	-53.38	197	1.6	H	-11.67	-65.05	-57.00	-8.05
374.25	-56.17	198	1.5	V	-11.67	-67.83	-57.00	-10.83
2490.52	-51.43	317	1.7	H	-6.80	-58.23	-47.00	-11.23
2490.52	-53.57	146	1.2	V	-6.80	-60.37	-47.00	-13.37

## 14. Adaptivity

### 14.1 Block Diagram Of Test Setup

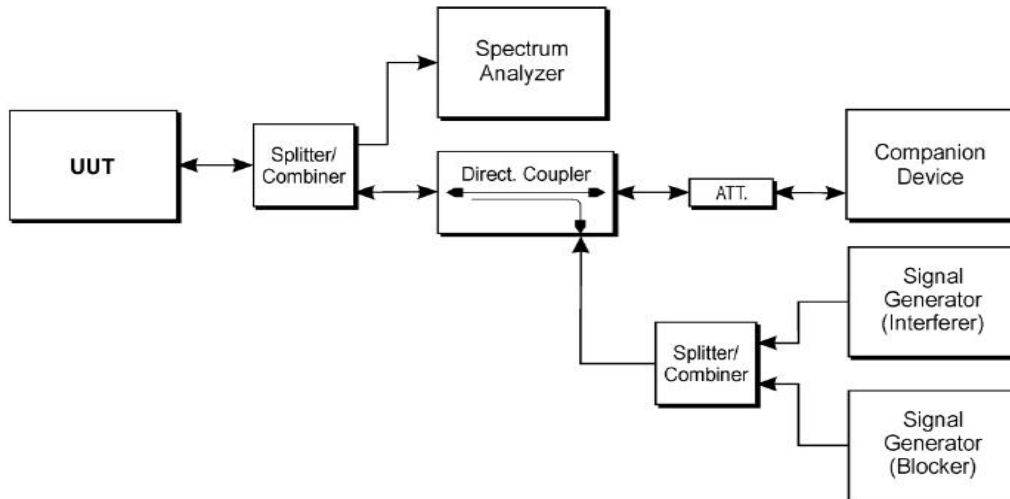

### 14.2 Limit

Requirement	Operational Mode		
	Frame Based Equipment	Load Based Equipment (CCA using 'energy detect')	Load Based Equipment (CCA not using any of the mechanisms referenced)
Minimum Clear Channel Assessment (CCA) Time	20 us (see note 1)	(see note 2)	20 us (see note 1)
Maximum Channel Occupancy (COT) Time	1ms to 10 ms	(see note 2)	$(13/32) \cdot q$ ms (see note 3)
Minimum Idle Period	5% of COT	(see note 2)	NA
Extended CCA check	NA	(see note 2)	$N \cdot CCA$ (see note 4)
Short Control Signalling Transmissions	Maximum duty cycle of 5% within an observation period of 50 ms (see note 5)		

Note 1: The CCA time used by the equipment shall be declared by the manufacturer.  
 Note 2: LBT based spectrum sharing mechanism based on the Clear Channel Assessment (CCA) mode using 'energy detect', as described in IEEE 802.11<sup>TM</sup>-2007[9], clauses 15 and 17, in IEEE 802.11n<sup>TM</sup>-2009[10], clauses 20.  
 Note 3: q is selected by the manufacturer in the range [4...32]  
 Note 4: The value of N shall be randomly selected in the range [1...q]  
 Note 5: Adaptive equipment may or may not have Short Control Signalling Transmissions.

### 14.3 Test Procedure

**Step 1:**

- The UUT shall connect to a companion device during the test. The signal generator, the spectrum analyzer, the UUT, the traffic source and the companion device are connected using a set-up equivalent to the example given by figure 14 although the interference source is switched off at this point in time. The spectrum analyzer is used to monitor the transmissions of the UUT in response to the interference signal. The traffic source might be part of the UUT itself.
- The received signal level (wanted signal from the companion device) at the UUT shall be sufficient to maintain a reliable link for the duration of the test. A typical value for the received signal level which can be used in most cases is -50 dBm/MHz.
- The analyzer shall be set as follows:
  - RBW:  $\geq$  Occupied Channel Bandwidth (if the analyzer does not support this setting, the highest available setting shall be used)
  - VBW:  $\geq$  RBW (if the analyzer does not support this setting, the highest available setting shall be used)
  - Detector Mode: RMS
  - Centre Frequency: Equal to the centre frequency of the operating channel
  - Span: 0 Hz
  - Sweep time:  $> 2 \times$  Channel Occupancy Time
  - Trace Mode: Clear/Write
  - Trigger Mode: Video or RF/IF Power

**Step 2:**

- Configure the traffic source so that it fills the UUT's buffers to a level causing the UUT to always have transmissions queued (buffer-ready-for-transmission condition) towards the companion device. Where this is not possible, the UUT shall be configured to occupy the Channel Occupancy Time of the Fixed Frame Period to the highest extent possible.
- To avoid adverse effects on the measurement results, a unidirectional traffic source should be used. An example of such a unidirectional traffic source not triggering reverse traffic on higher layer protocols is UDP.

### 14.4 Test Result

Pass

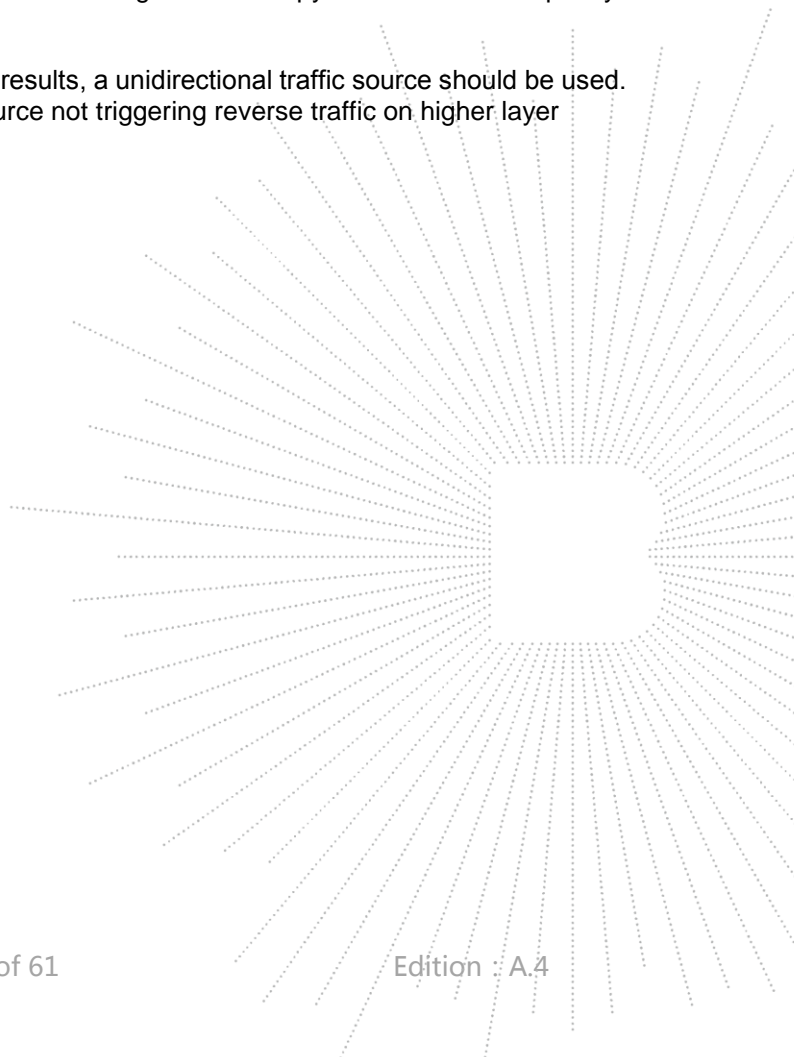

## 15. Receiver Blocking

### 15.1 Block Diagram Of Test Setup

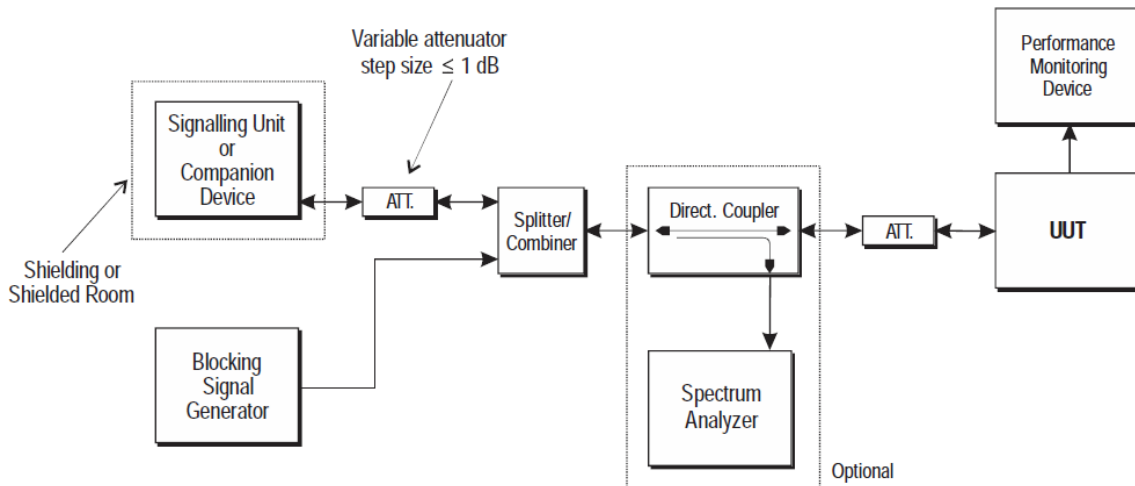

### 15.2 Limit

Wanted signal mean power from companion device (dBm)	Blocking signal frequency (MHz)	Blocking signal power (dBm) (see note 2)		Type of blocking signal
		Master or Slave with radar detection (see table D.2, note 2)	Slave without radar detection (see table D.2, note 2)	
$P_{min} + 6$ dB	5 100	-53	-59	Continuous Wave
$P_{min} + 6$ dB	4 900 5 000 5 975	-47	-53	Continuous Wave

NOTE 1:  $P_{min}$  is the minimum level of the wanted signal (in dBm) required to meet the minimum performance criteria as defined clause 4.2.8.3 in the absence of any blocking signal.

NOTE 2: The levels specified are levels in front of the UUT antenna. In case of conducted measurements, the same levels should be used at the antenna connector irrespective of antenna gain.

### 15.3 Test Procedure

**Step 1:**

- The UUT shall be set to the first operating frequency to be tested (see clause 5.3.2).

**Step 2:**

- The blocking signal generator is set to the first frequency as defined in table 9.

**Step 3:**

- With the blocking signal generator switched off a communication link is set up between the UUT and the associated companion device using the test setup shown in figure 18. The attenuation of the variable attenuator shall be increased in 1 dB steps to a value at which the minimum performance criteria as specified in clause 4.2.8.3 is still met. The resulting level for the wanted signal at the input of the UUT is  $P_{min}$ .
- This signal level ( $P_{min}$ ) is increased by 6 dB resulting in a new level ( $P_{min} + 6$  dB) of the wanted signal at the UUT receiver input.

**Step 4:**

- The level of the blocking signal at the UUT input is set to the level provided in table 9. It shall be verified and recorded in the test report that the performance criteria as specified in clause 4.2.8.3 are met.
- If the performance criteria as specified in clause 4.2.8.3 are met, the level of the blocking signal at the UUT may be further increased (e.g. in steps of 1 dB) until the level whereby the performance criteria as specified in clause 4.2.8.3 are no longer met. The highest level at which the performance criteria are met is recorded in the test report.

**Step 5:**

- Repeat step 4 for each remaining combination of frequency and level as specified in table 9.

**Step 6:**

- Repeat step 2 to step 5 with the UUT operating at the other operating frequencies at which the blocking test has to be performed. See clause 5.3.2.

## 15.4 Test Result

The worst mode(802.11a)

Transmitting	$P_{min}$ (dBm)	Blocking Frequency(MHz)	Blocking Power(dB)	Measured PER(%)	Limit (%)
5180	-74	5100	-53	3.32	10
5180	-74	4900	-47	2.15	10
5180	-74	5000	-47	2.84	10
5180	-74	5975	-47	1.00	10
5240	-73	5100	-53	1.53	10
5240	-73	4900	-47	1.62	10
5240	-73	5000	-47	4.27	10
5240	-73	5975	-47	4.63	10

## 16. User Access Restrictions

### 16.1 Applicable Standard

ETSI EN 301 893 clause 4.2.9

### 16.2 Conformance Limit

The equipment shall be so constructed that settings (hardware and/or software) related to DFS shall not be accessible to the user if changing those settings result in the equipment no longer being compliant with the DFS requirements in clause 4.2.6.

### 16.3 Test Results

The EUT can restrain user to restrict access to hardware and software setting of the equipment through making it be disabled and altered.

PASS



**17. EUT Photographs**

**EUT Photo 1**

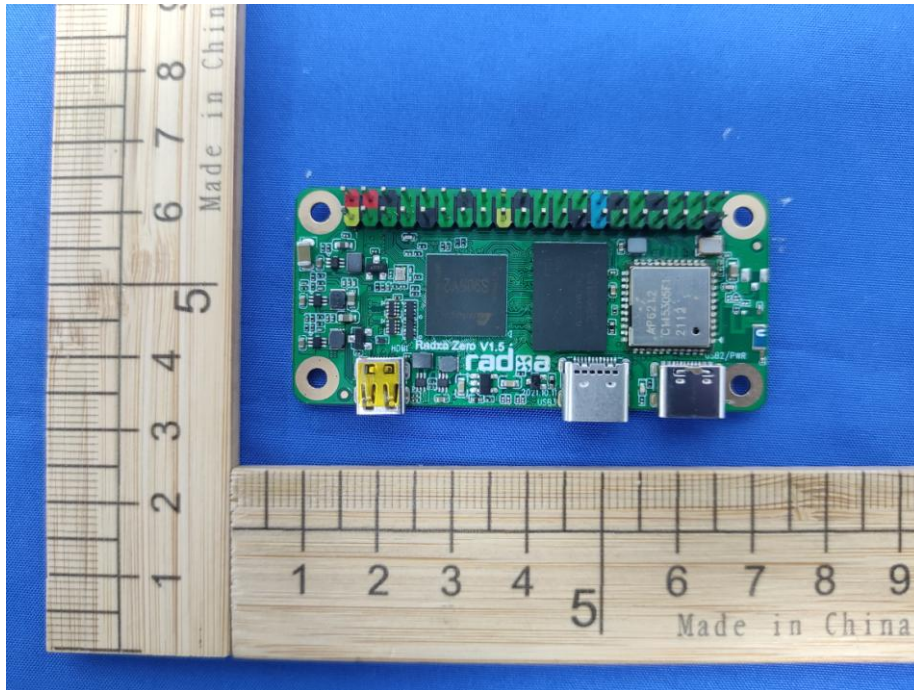

**EUT Photo 2**

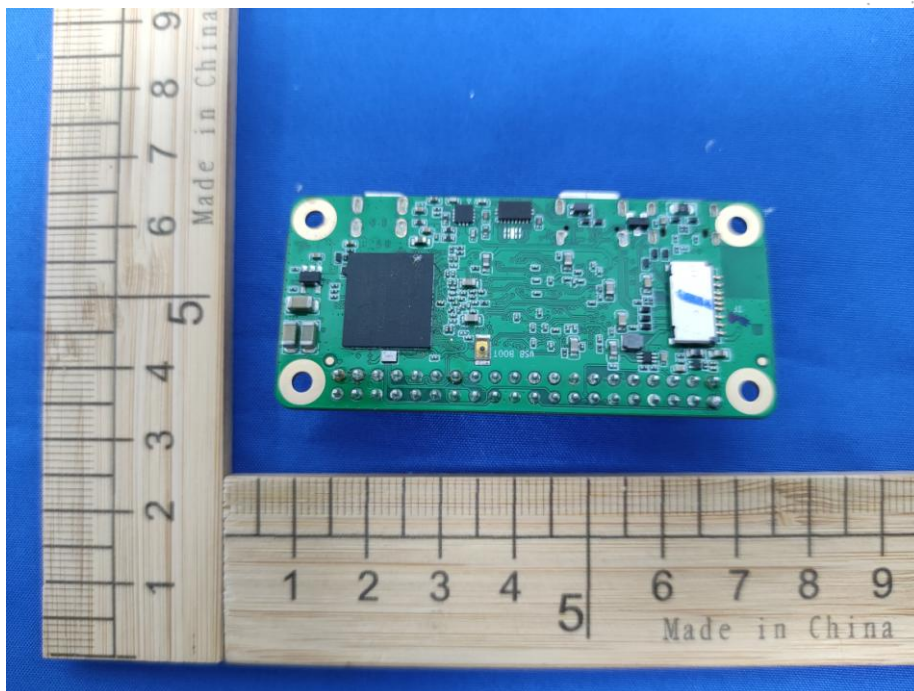



**EUT Photo 3**

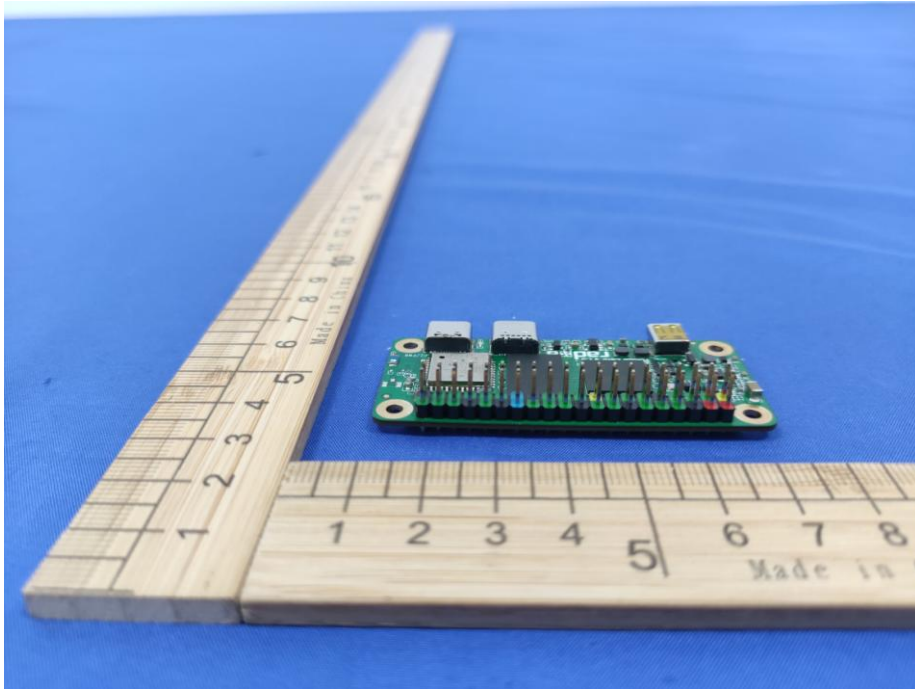

**EUT Photo 4**

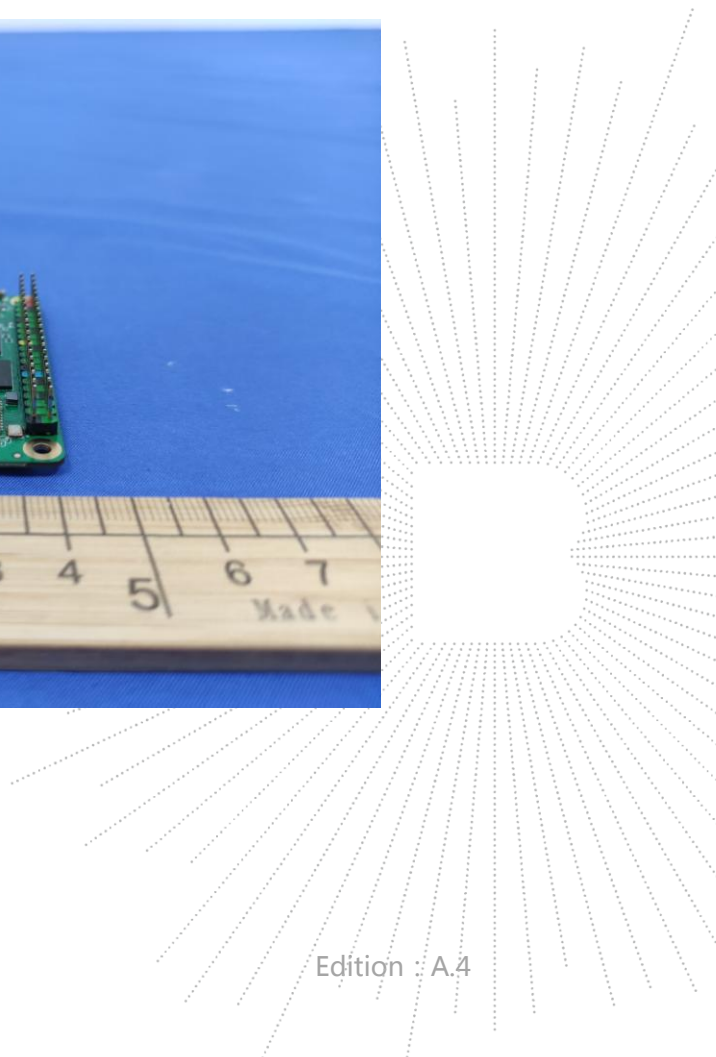
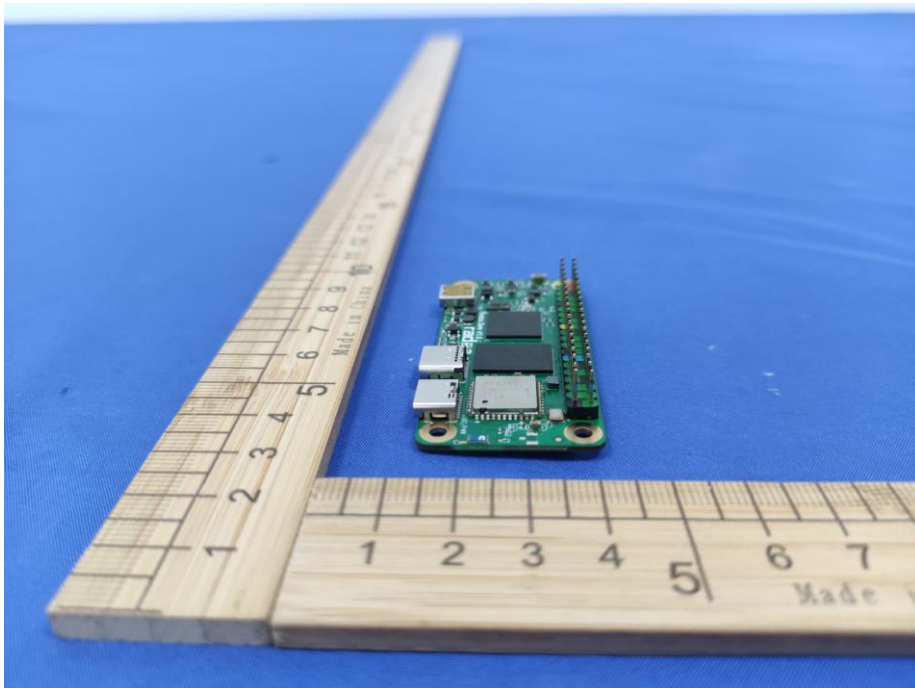

**EUT Photo 5**

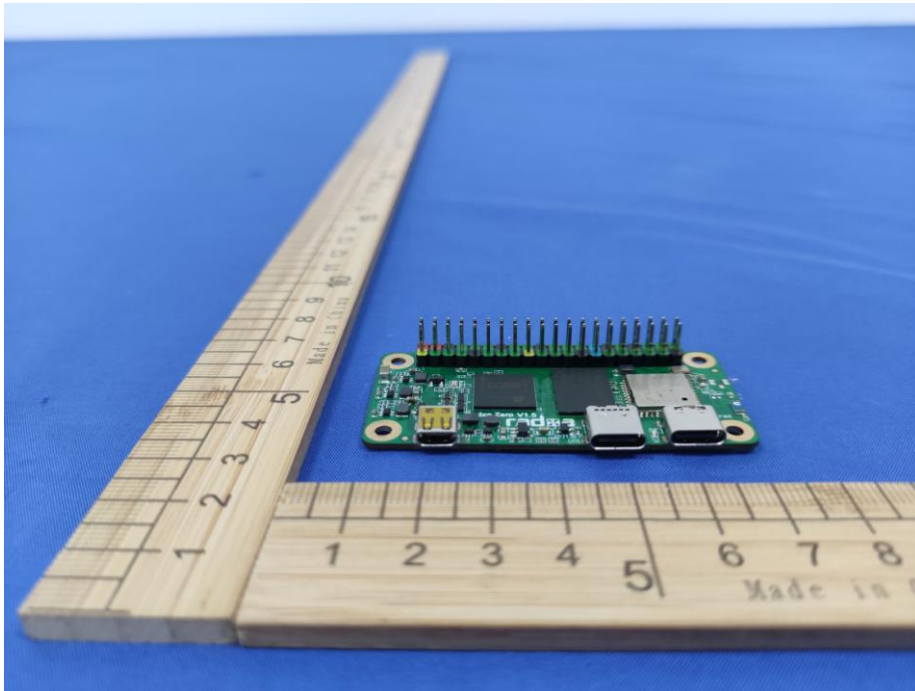

**EUT Photo 6**

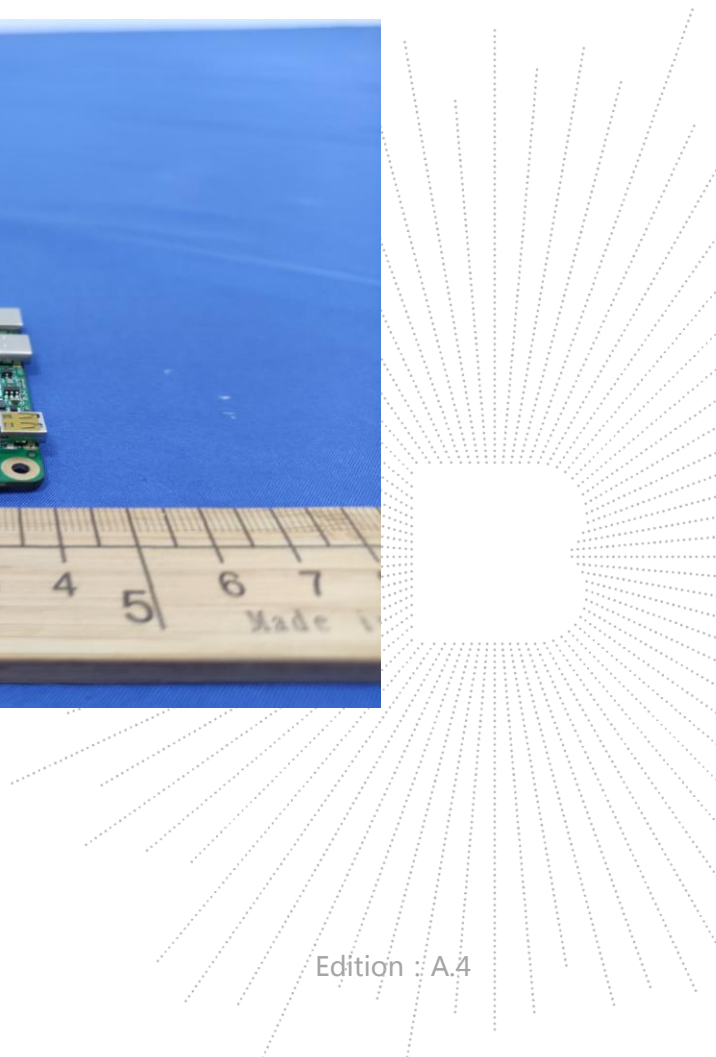
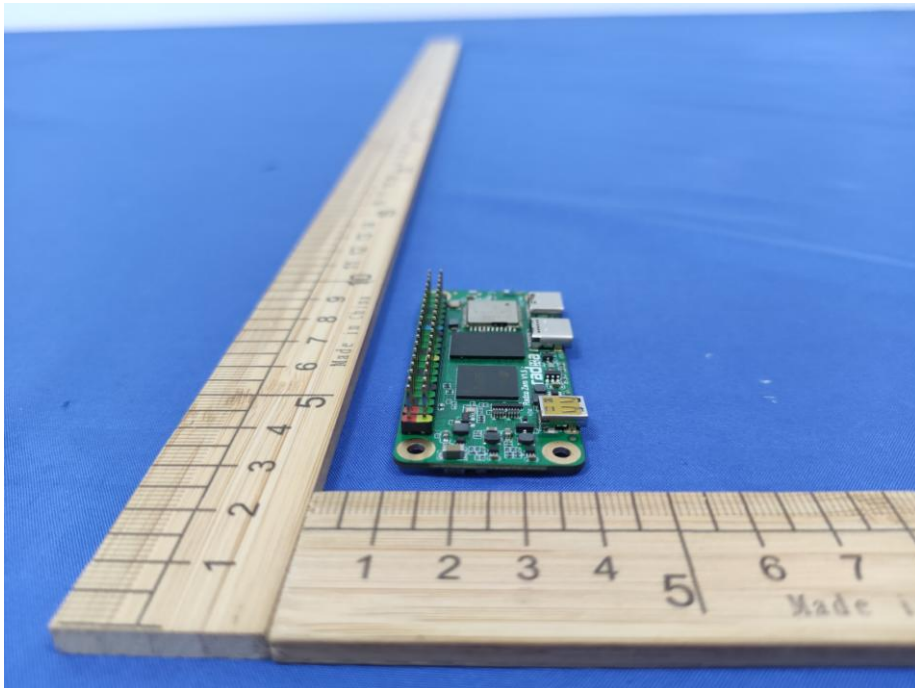

EUT Photo 7

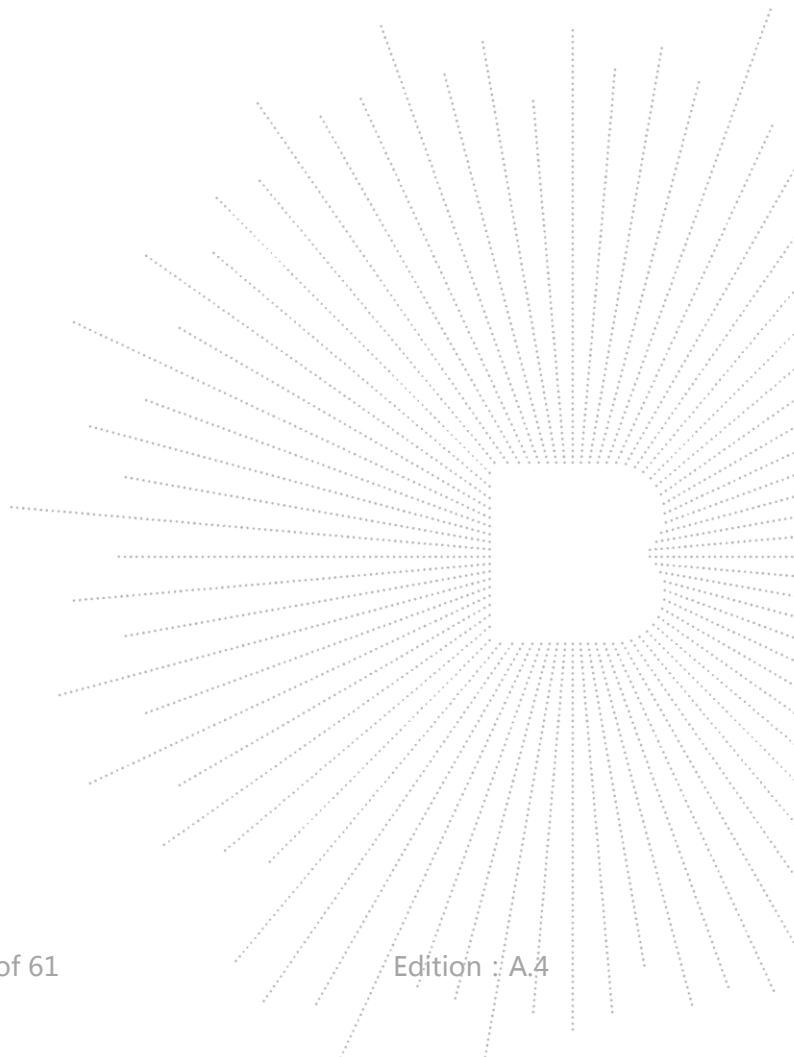
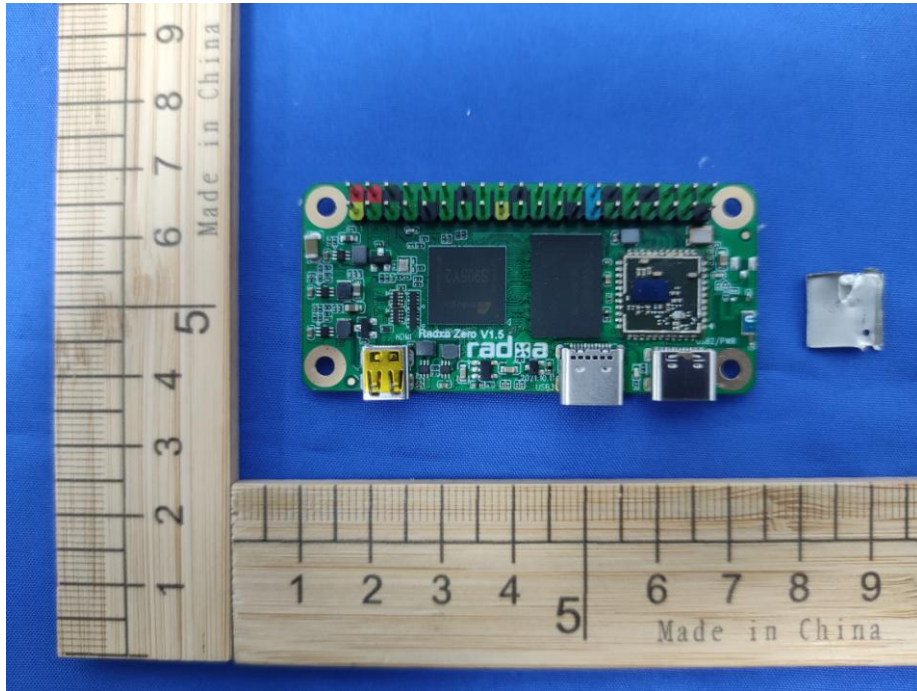

**18. EUT Test Setup Photographs**

Spurious emissions





## STATEMENT

- 1.The equipment lists are traceable to the national reference standards.
- 2.The test report can not be partially copied unless prior written approval is issued from our lab.
- 3.The test report is invalid without stamp of laboratory.
- 4.The test report is invalid without signature of person(s) testing and authorizing.
- 5.The test process and test result is only related to the Unit Under Test.
- 6.The quality system of our laboratory is in accordance with ISO/IEC17025.
- 7.If there is any objection to report, the client should inform issuing laboratory within 15 days from the date of receiving test report.

Address:

1-2/F., Building B, Pengzhou Industrial Park, No.158, Fuyuan 1st Road, Tangwei, Fuhai Subdistrict, Bao'an District, Shenzhen, Guangdong, China

TEL : 400-788-9558

P.C.: 518103

FAX : 0755-33229357

Website : <http://www.chnbctc.com>

E-Mail : [bctc@bctc-lab.com.cn](mailto:bctc@bctc-lab.com.cn)

\*\*\*\*\* END \*\*\*\*\*

