

Page Index

01-	Block
02-	Power tree
P01	Power
P02	CPU
P03	eMMC
P04	LPDDR4&DVSS
P05	HDMI
P06	USB
P07	WIFI Power
P08	WIFI SDIO&ANT

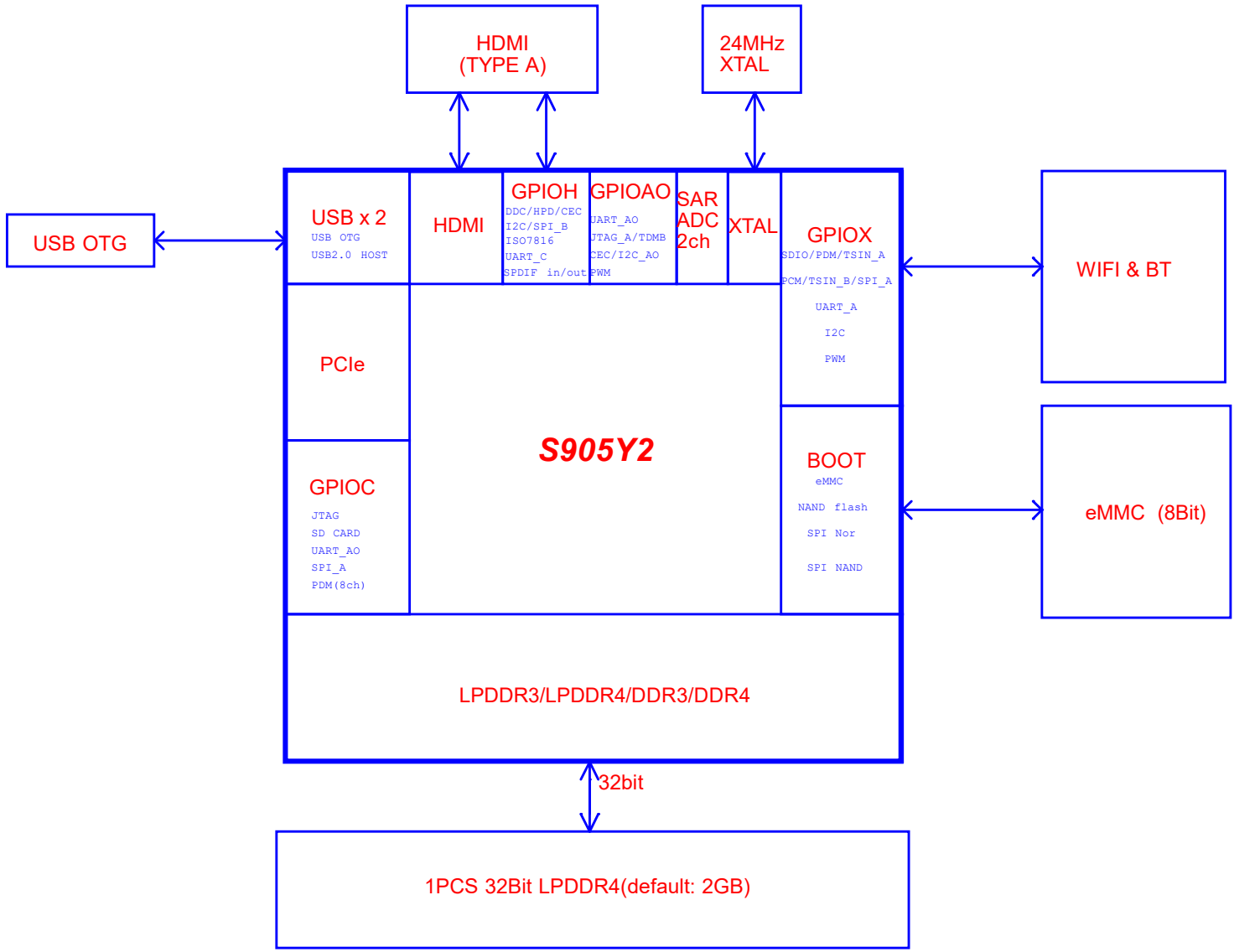

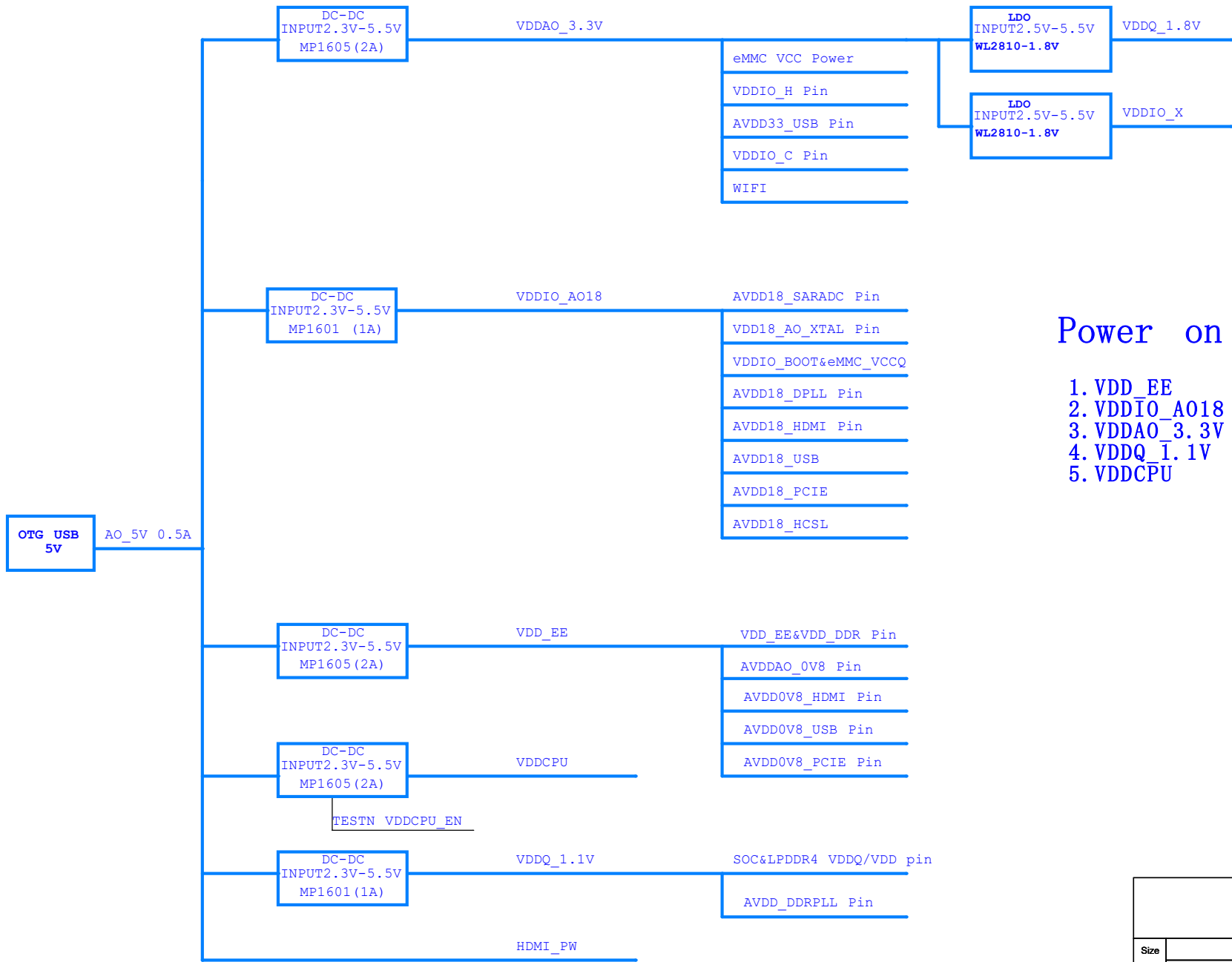

## Power on sequence

1. VDD\_EE
2. VDDIO\_A018
3. VDDAO\_3.3V
4. VDDQ\_1.1V
5. VDDCPU



Size	Radxa Zero		REV
B	Page Name:	Power tree	1.4
Date:	Friday, July 09, 2021	Sheet	2 of 9

5V to VDDA0\_3.3V Design Max: 1A

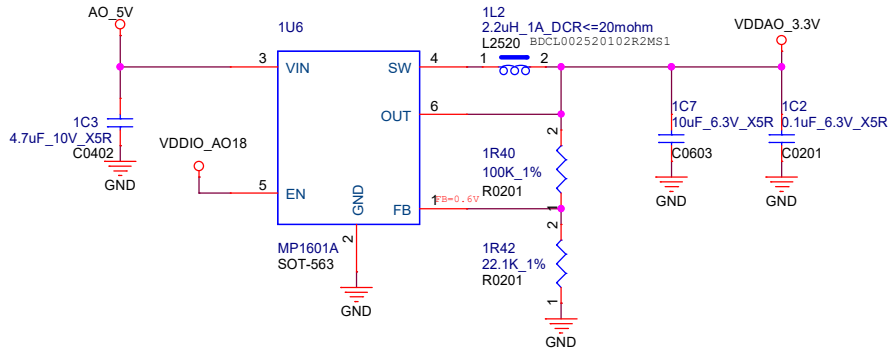

5V to VDDIO\_AO18 Design Max:1A

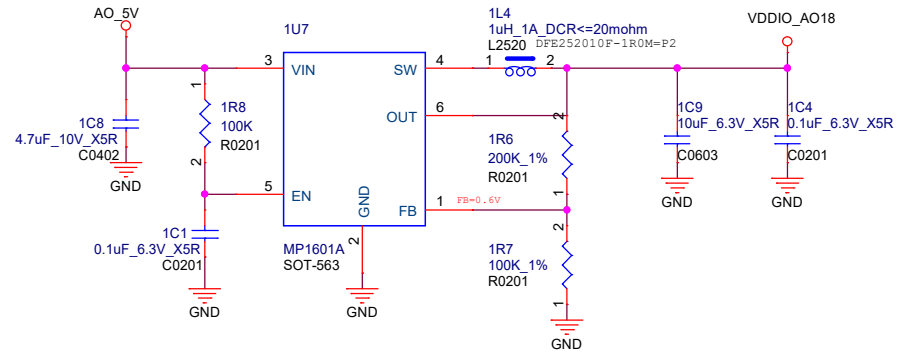

5V to VDD\_BE Design Max: 2A

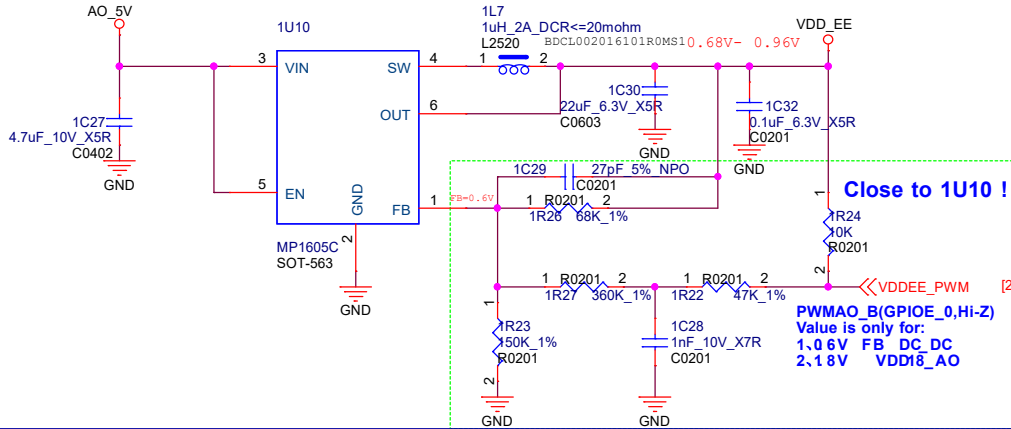

5V to VDDQ\_1.2V Design Max: 1A

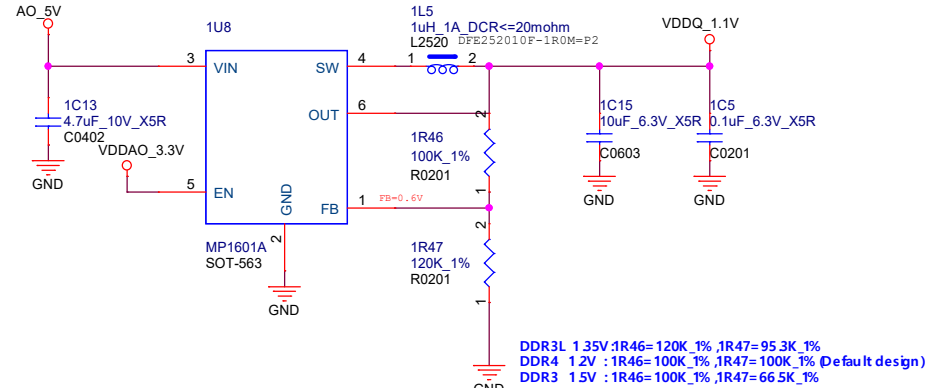

5V to VDDCPU Design Max: 2A

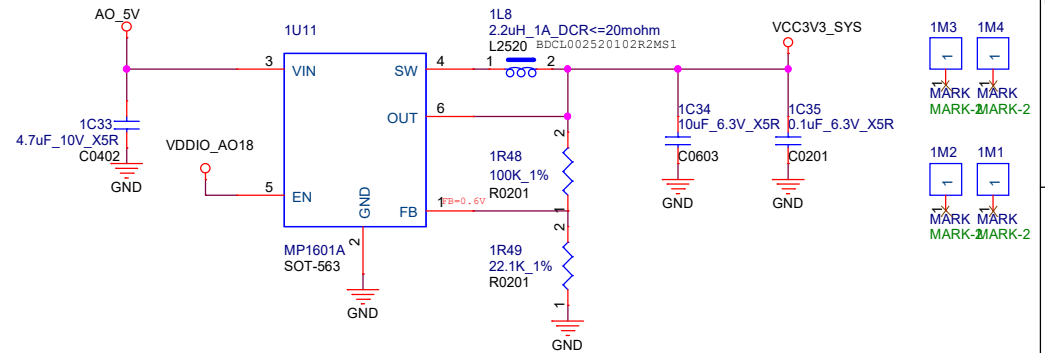
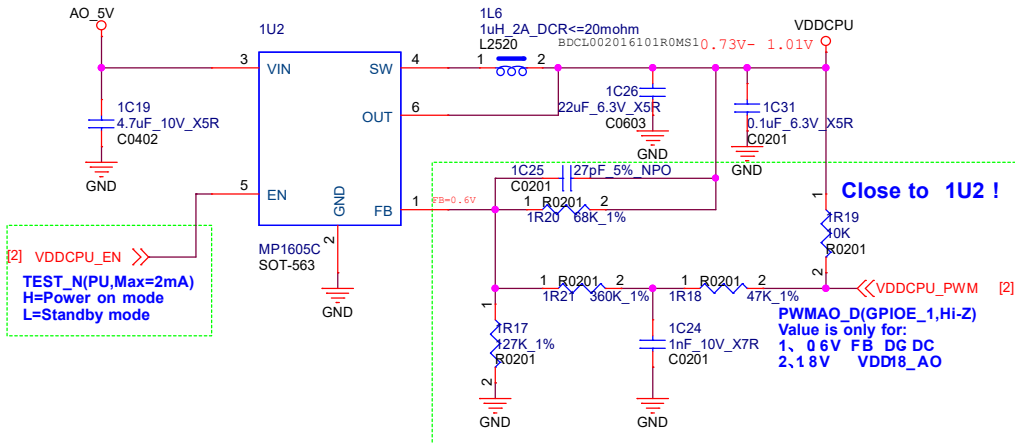

Size	Radxa Zero	REV
Customer Name:	Power	1.4
Date: Friday, July 09, 2021	Sheet	3 of 9

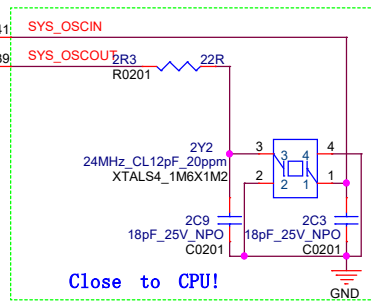
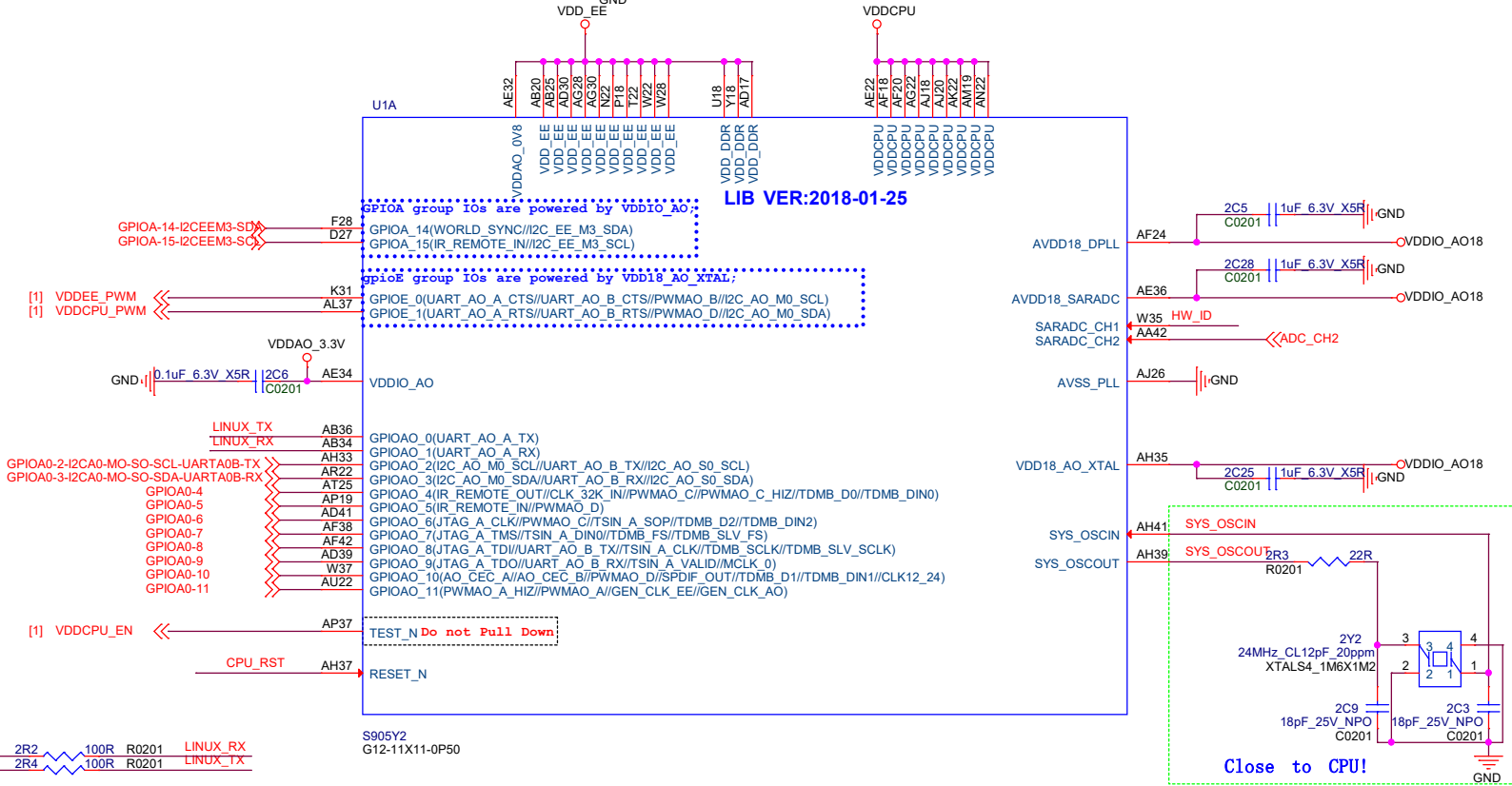
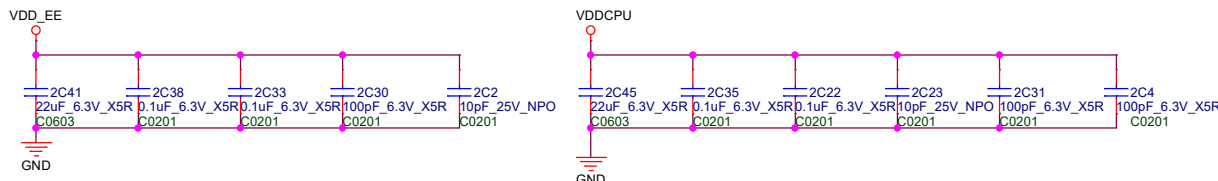

VBAT is for routing convenient. Normally should use VDDIO\_AO 3.3V here.

**For linux debug**

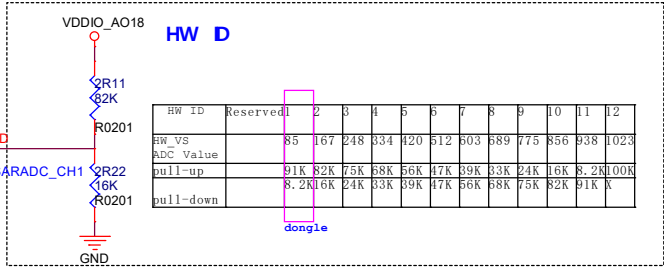
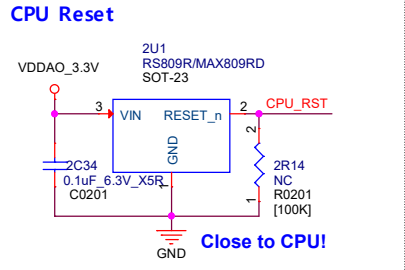

HW ID	Reserved	2	3	4	5	6	7	8	9	10	11	12
HW_Vs		85	167	248	334	420	512	603	689	776	856	938
ADC Value		91K	82K	75K	68K	56K	47K	39K	33K	24K	16K	8.2K
pull-up		8.2K	16K	24K	33K	39K	47K	56K	68K	75K	82K	91K
pull-down												

# eMMC

PCB Decal:169pin balls Type(BGA)

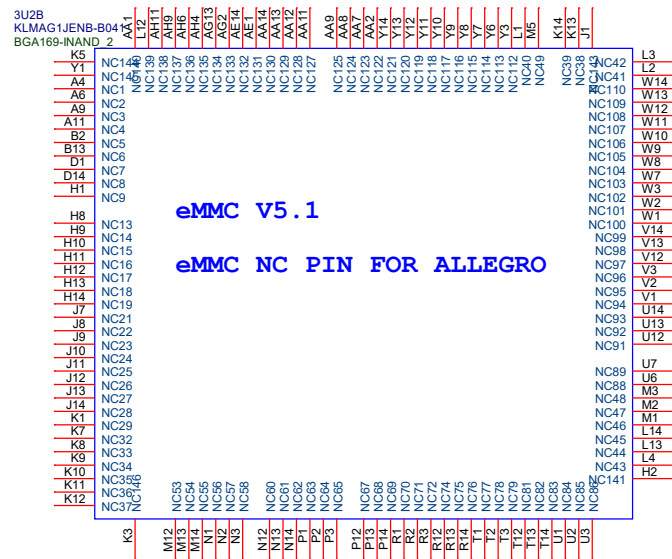
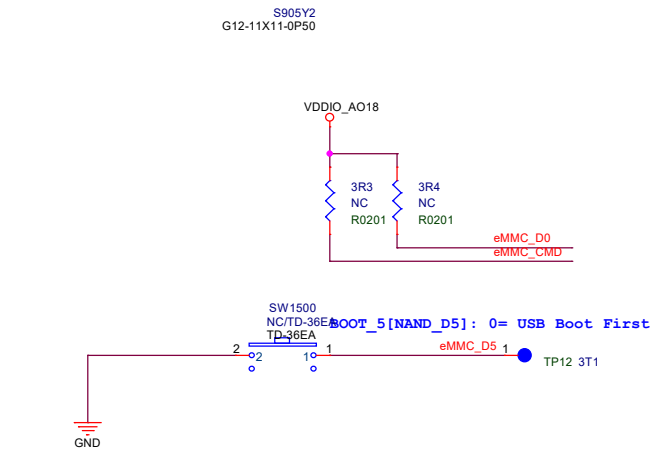
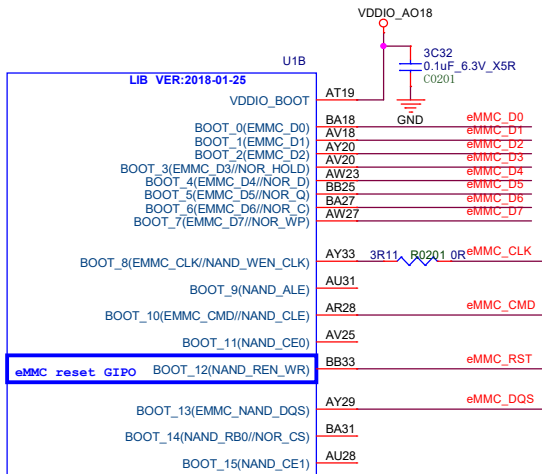
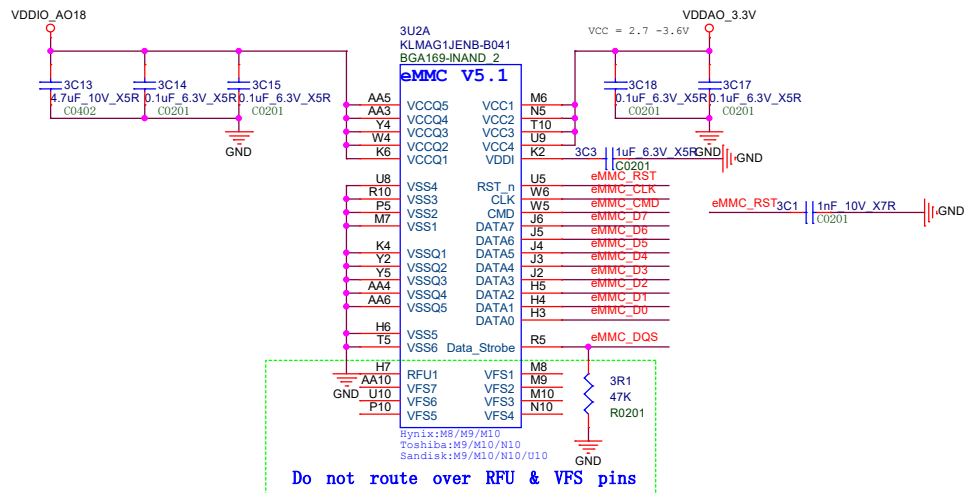

U1C LIB VER:2018-01-25

DDR_CKEA0	AM4	AC_0 /CKEA0 /CKE0	CKE0	AR16	DDR_DQ0
DDR_CKEA1	AN10	AC_1 /CKEA1 /CKE1	CKE1	DDR_DQ1	BB16
DDR_CS#0	AK1	AC_2 /CSA0 /CSA0 /CS_NO	CS_NO	DDR_DQ2	BB18
DDR_CS#1	AL3	AC_3 /CSA1 /CSA1 /CS_NO	CS_NO	DDR_DQ3	AU18
DDR_CLKA_T	T8	AC_4 /CLKA_T /CLKA_T /CAS_N	/A6	DDR_DQ4	AR10
DDR_CLKA_C	TE	AC_5 /CLKA_C /CLKA_C /BA2	/A8	DDR_DQ5	AU7
	AB7	AC_6 /INC /INC /A7	/A2	DDR_DQ6	ARY
	AB9	AC_7 /INC /INC /A5	/A11	DDR_DQ7	AR13
				DDR_DQ8	AW14
				DDR_DQ9	BA14
				DDR_DQ10	
				DDR_DQ11	
				DDR_DQ12	
				DDR_DQ13	
				DDR_DQ14	
				DDR_DQ15	
				DDR_DQ16	
				DDR_DQ17	
				DDR_DQ18	
				DDR_DQ19	
				DDR_DQ20	
				DDR_DQ21	
				DDR_DQ22	
				DDR_DQ23	
				DDR_DQ24	
				DDR_DQ25	
				DDR_DQ26	
				DDR_DQ27	
				DDR_DQ28	
				DDR_DQ29	
				DDR_DQ30	
				DDR_DQ31	
				DDR_DQ32	
				DDR_DQ33	
				DDR_DQ34	
				DDR_DQ35	
				DDR_DQ36	
				DDR_DQ37	
				DDR_DQ38	
				DDR_DQ39	
				DDR_DQ40	
				DDR_DQ41	
				DDR_DQ42	
				DDR_DQ43	
				DDR_DQ44	
				DDR_DQ45	
				DDR_DQ46	
				DDR_DQ47	
				DDR_DQ48	
				DDR_DQ49	
				DDR_DQ50	
				DDR_DQ51	
				DDR_DQ52	
				DDR_DQ53	
				DDR_DQ54	
				DDR_DQ55	
				DDR_DQ56	
				DDR_DQ57	
				DDR_DQ58	
				DDR_DQ59	
				DDR_DQ60	
				DDR_DQ61	
				DDR_DQ62	
				DDR_DQ63	
				DDR_DQ64	
				DDR_DQ65	
				DDR_DQ66	
				DDR_DQ67	
				DDR_DQ68	
				DDR_DQ69	
				DDR_DQ70	
				DDR_DQ71	
				DDR_DQ72	
				DDR_DQ73	
				DDR_DQ74	
				DDR_DQ75	
				DDR_DQ76	
				DDR_DQ77	
				DDR_DQ78	
				DDR_DQ79	
				DDR_DQ80	
				DDR_DQ81	
				DDR_DQ82	
				DDR_DQ83	
				DDR_DQ84	
				DDR_DQ85	
				DDR_DQ86	
				DDR_DQ87	
				DDR_DQ88	
				DDR_DQ89	
				DDR_DQ90	
				DDR_DQ91	
				DDR_DQ92	
				DDR_DQ93	
				DDR_DQ94	
				DDR_DQ95	
				DDR_DQ96	
				DDR_DQ97	
				DDR_DQ98	
				DDR_DQ99	
				DDR_DQ100	

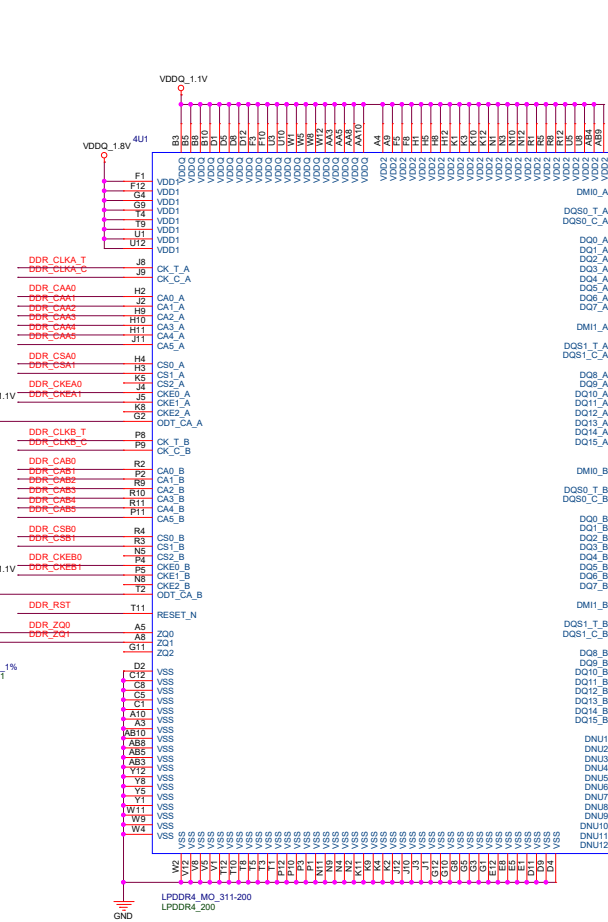
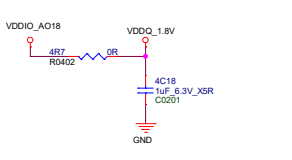

D3	DDR_DOM1
D30	DDR_DQS#1
E3	DDR_DQS#11
D0	DDR_DQ14
D2	DDR_DQ12
F2	DDR_DQ15
D5	DDR_DQ16
E4	DDR_DQ8
F4	DDR_DQ11
D6	DDR_DQ13
D2	DDR_DQ10
D7	DDR_DQ17
C10	DDR_DOM0
D10	DDR_DQS#0
D10	DDR_DQS#10
E10	DDR_DQS#16
B11	DDR_DQ3
D08	DDR_DQ2
D09	DDR_DQ1
D10	DDR_DQ4
D11	DDR_DQ7
E9	DDR_DQ6
D13	DDR_DQ5
D14	DDR_DQ4
D14	DDR_DQ9
Y3	DDR_DOM2
W3	DDR_DQS#2
Y3	DDR_DQS#12
AA2	DDR_DQ20
Y2	DDR_DQ21
V2	DDR_DQ22
U4	DDR_DQ23
U4	DDR_DQ18
U6	DDR_DQ19
Y4	DDR_DQ15
AA4	DDR_DQ18
W10	DDR_DOM3
W10	DDR_DQS#3
V10	DDR_DQS#13
AA11	DDR_DQ24
V11	DDR_DQ25
U11	DDR_DQ26
U11	DDR_DQ27
V9	DDR_DQ30
Y9	DDR_DQ27
ZA8	DDR_DQ28
D15	DDR_DQ29
A1	DNUI1
A2	DNUI2
A11	DNUI3
A12	DNUI4
B1	DNUI5
B2	DNUI6
AA1	DNUI7
AA12	DNUI8
AA3	DNUI9
AB2	DNUI10
AB11	DNUI11
AB12	DNUI12

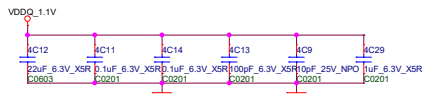

A12	DVSS	DVSS	B35
A22	DVSS	DVSS	BB
AA3	DVSS	DVSS	BA35
AA5	DVSS	DVSS	B45
AB11	DVSS	DVSS	BB12
AB17	DVSS	DVSS	BB20
AB28	DVSS	DVSS	BB39
AB30	DVSS	DVSS	BB3
AD16	DVSS	DVSS	C4
AD20	DVSS	DVSS	D10
AD1	DVSS	DVSS	D31
AE11	DVSS	DVSS	E20
AF1	DVSS	DVSS	E25
AF40	DVSS	DVSS	F10
AG12	DVSS	DVSS	G25
AG16	DVSS	DVSS	G33
AH4	DVSS	DVSS	G41
AJ24	DVSS	DVSS	K15
AJ30	DVSS	DVSS	K16
AK12	DVSS	DVSS	K22
AK14	DVSS	DVSS	L19
AK16	DVSS	DVSS	L2
AK28	DVSS	DVSS	L38
AK42	DVSS	DVSS	L4
AL10	DVSS	DVSS	N12
AL24	DVSS	DVSS	N16
AL30	DVSS	DVSS	N42
AL33	DVSS	DVSS	N20
AM2	DVSS	DVSS	P24
AM25	DVSS	DVSS	R4
AN13	DVSS	DVSS	T12
AN16	DVSS	DVSS	T16
AN28	DVSS	DVSS	T11
AN31	DVSS	DVSS	U20
AN7	DVSS	DVSS	U24
AP3	DVSS	DVSS	U25
AP40	DVSS	DVSS	U30
AV1	DVSS	DVSS	U40
AV42	DVSS	DVSS	W12
AW10	DVSS	DVSS	W16
AW11	DVSS	DVSS	W30
AY16	DVSS	DVSS	W8
AY25	DVSS	DVSS	Y25
AY39	DVSS	DVSS	Y24
B18	DVSS	DVSS	Y26
AC23	DVSS	DVSS	

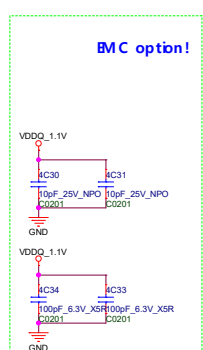
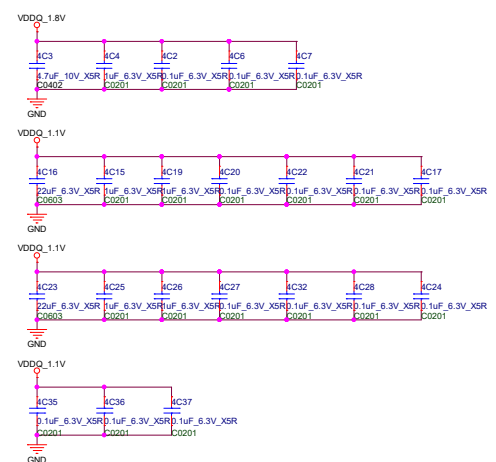

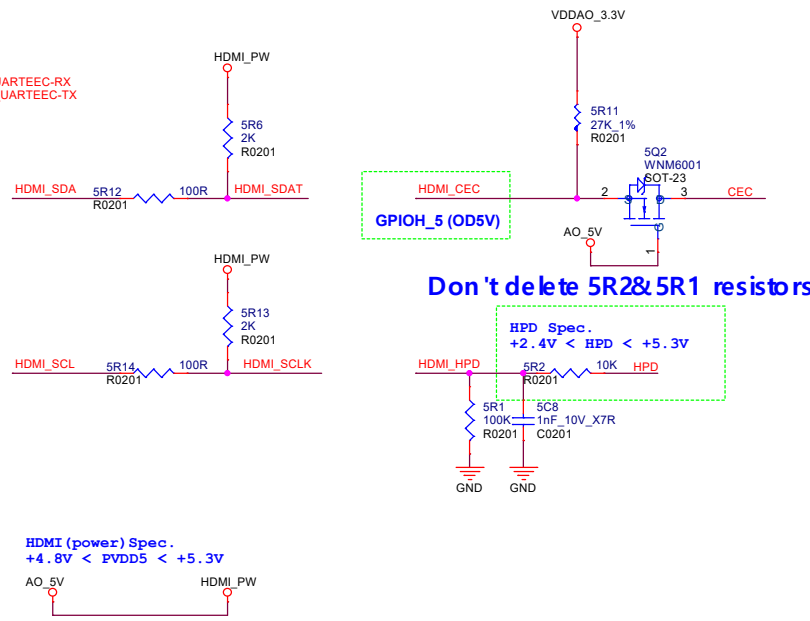
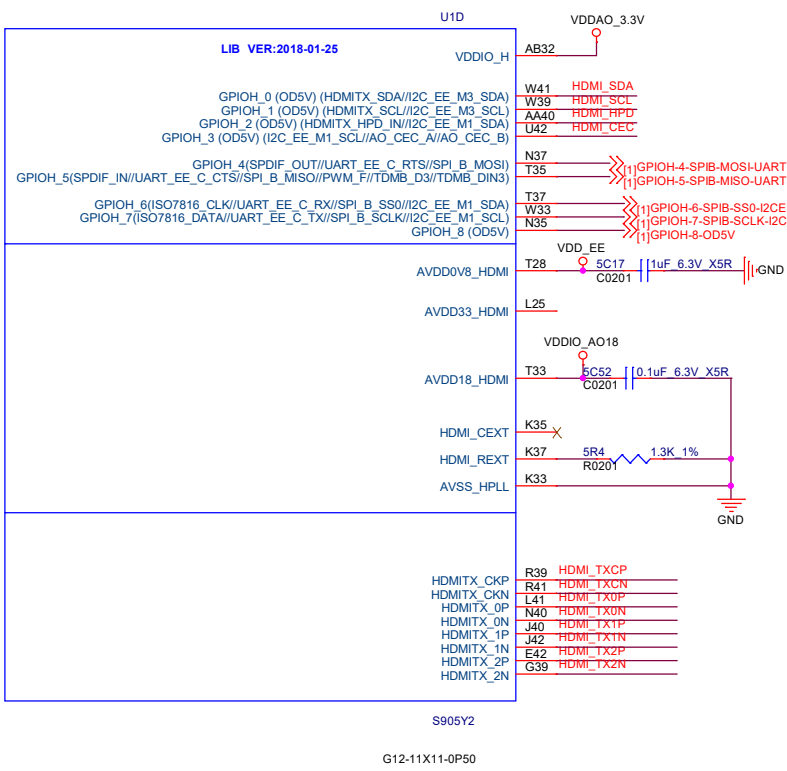
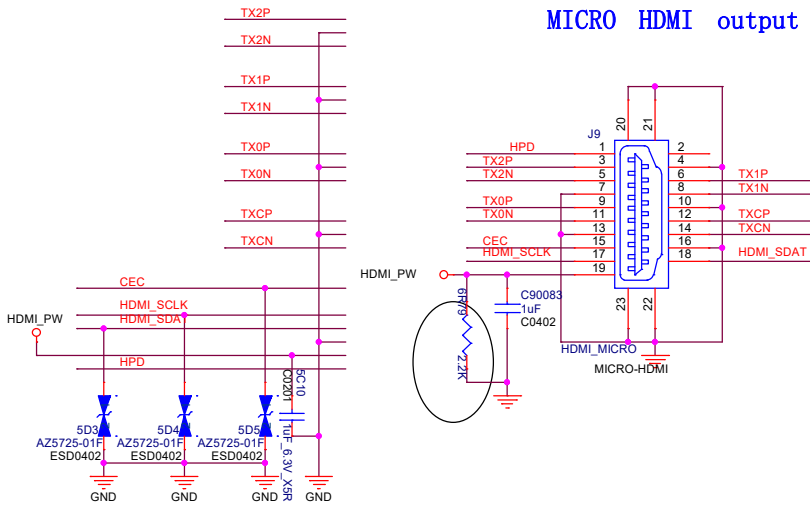
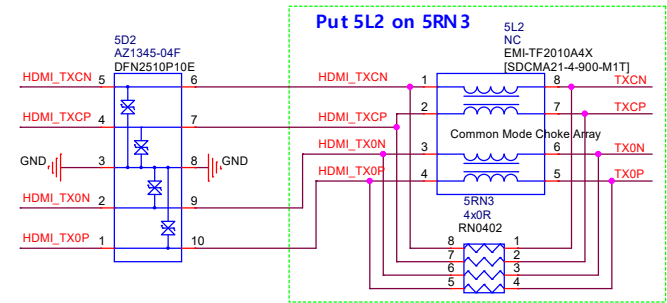
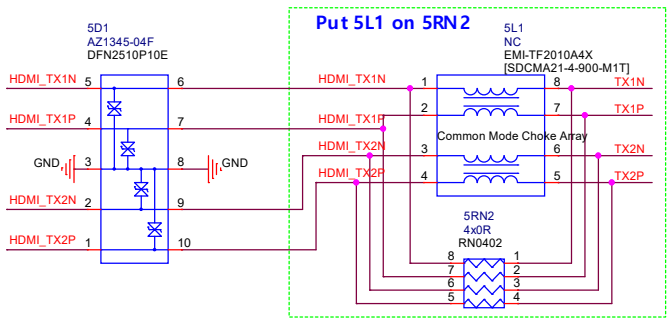

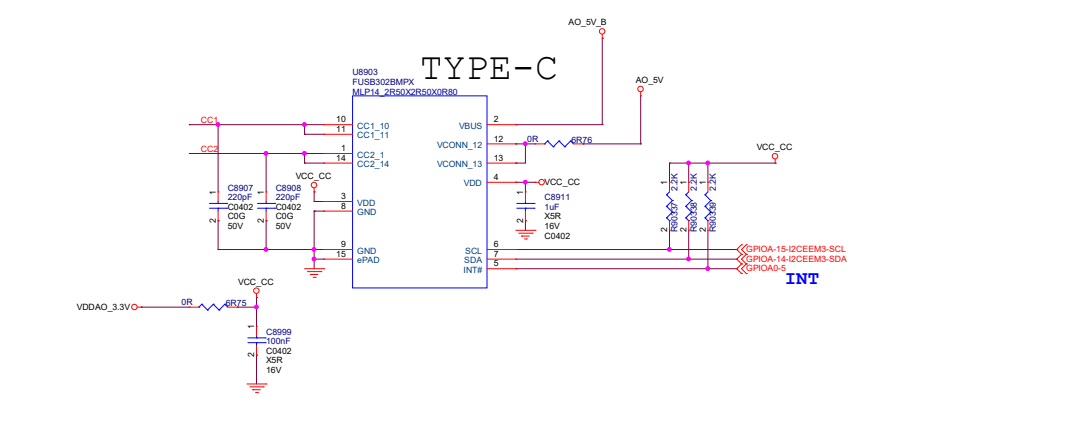
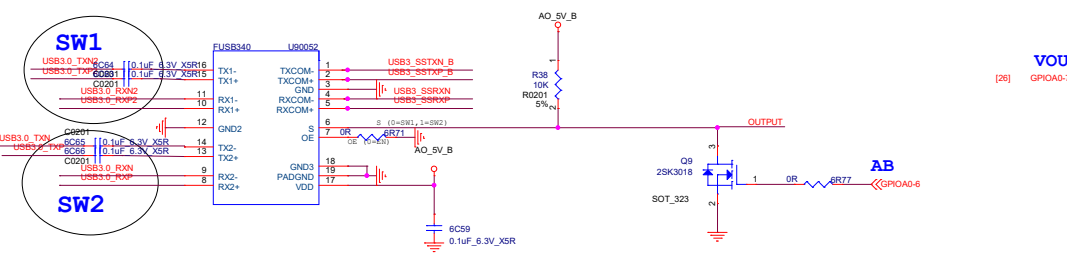
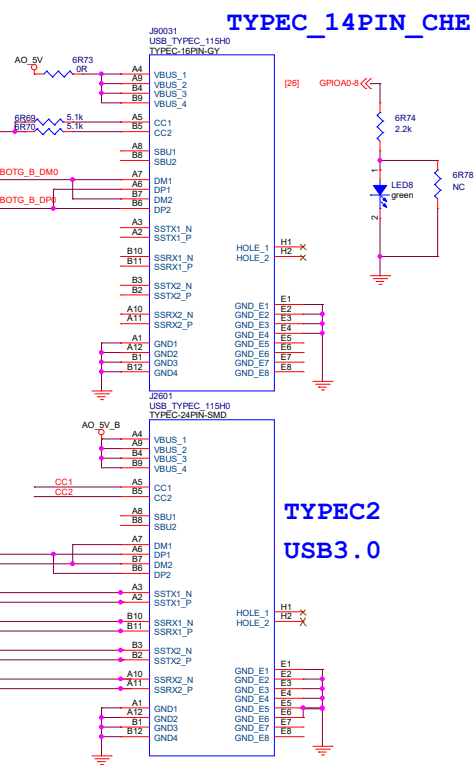
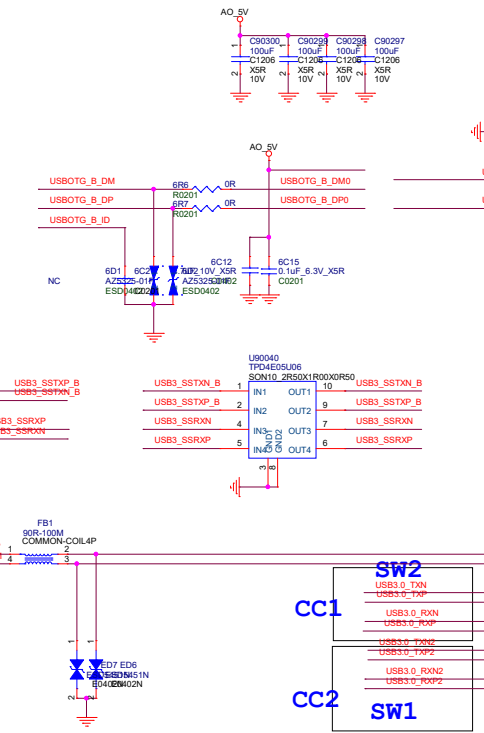
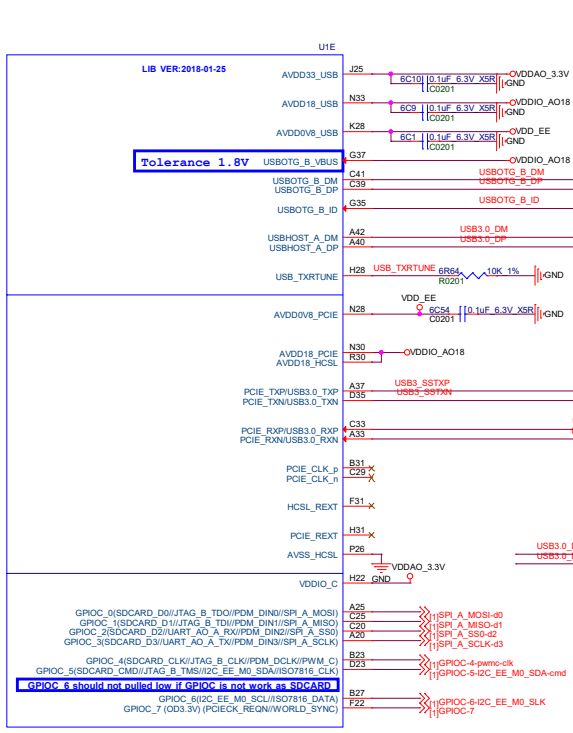



### 3.3V1A

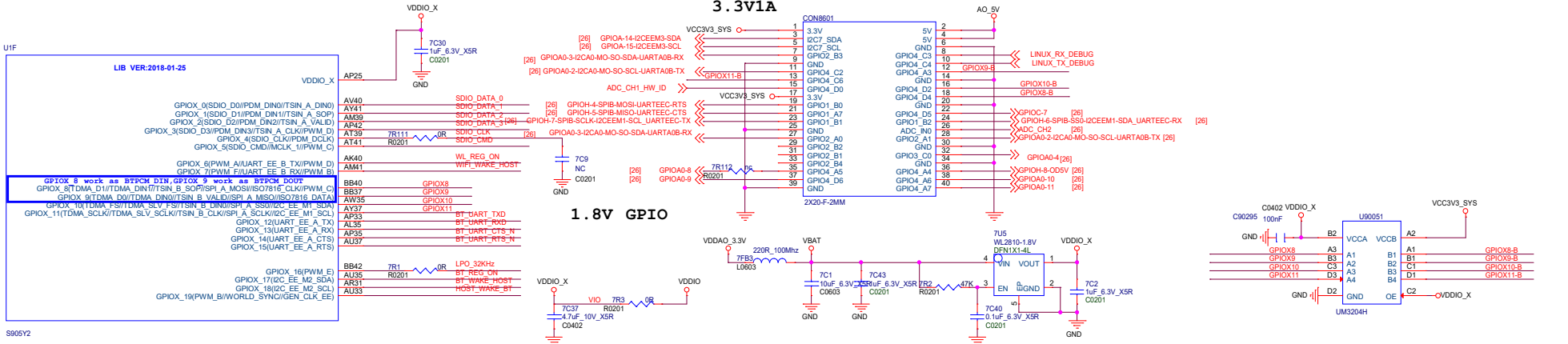

### 1.8V GPIO

### SDIO WIFI/BT-171R

Note: VBAT voltage range is 3.0V-4.8V, and peak-current is at least 400mA.

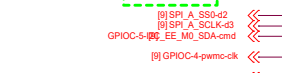
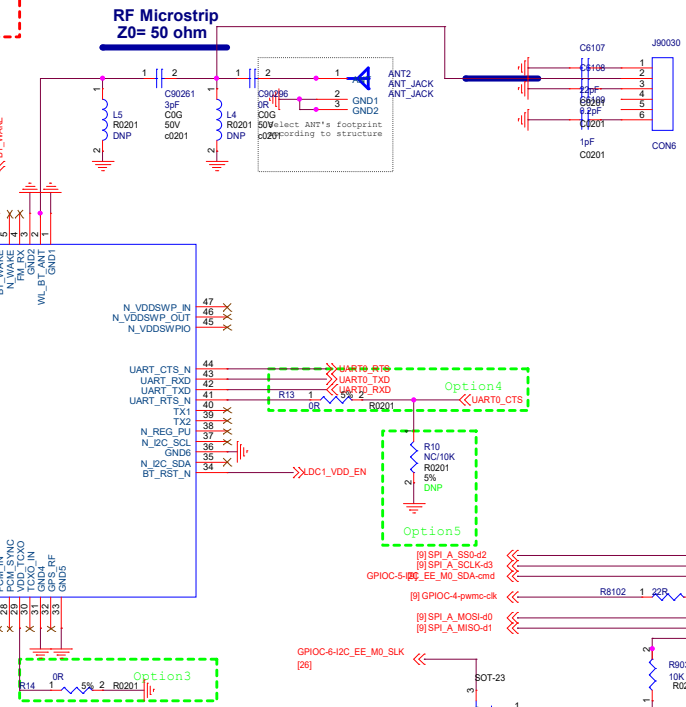
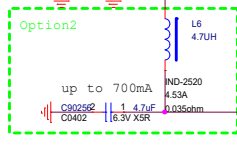
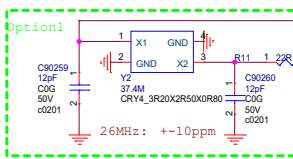
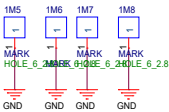

Note:  
 Yes: option circuit be mounted  
 No: option circuit not be mounted

OPTION	WIFI				BT	Crystals	VCCIO_SDIO	OPTION1	OPTION2	OPTION3	OPTION4	OPTION5
	a	b/g/n	ac	5GHz								
AW-CM256SM	Yes	Yes	Yes	Yes	4.2	37.4MHz	1.71-3.63V	Yes	Yes	Yes@SDIO2.0 No@SDIO3.0	Yes	No
AP6236/AP6212	No	Yes	No	No	4.2/4.0	26MHz	1.71-3.63V	Yes	Yes	No	Yes	No
AP6256/AP6255	Yes	Yes	Yes	Yes	5.0/4.2	37.4MHz	1.62-3.63V	Yes	Yes	Yes@SDIO2.0 No@SDIO3.0	Yes	No
RTL8189FTV Module F89FTSM12-W3	No	Yes	No	No	No	Module Integrated	1.8-3.3V	No	No	No	Yes	No
RTL8723DS Module 6223A-SRD	No	Yes	No	No	4.2	Module Integrated	1.62-3.63V	No	No	No	No	Yes
QCA9377 Module 8223A-SR	Yes	Yes	Yes	Yes	4.2	Module Integrated	1.7-3.45V	No	No	No	Yes	No
RTL8821CS Module 6221A-SRC	Yes	Yes	Yes	Yes	4.2	Module Integrated	4.7-3.45V	No	No	No	Yes	No