



Radxa ZERO schematic

V1.51



Index

Page 1	01.Cover
Page 2	02.Index
Page 3	03.Block
Page 4	04.eMMC
Page 5	05.CPU
Page 6	06.Power
Page 7	07.HDMI
Page 8	08.LPDDR4&DVSS
Page 9	09.USB
Page 10	10.WIFI SDIO&ANT



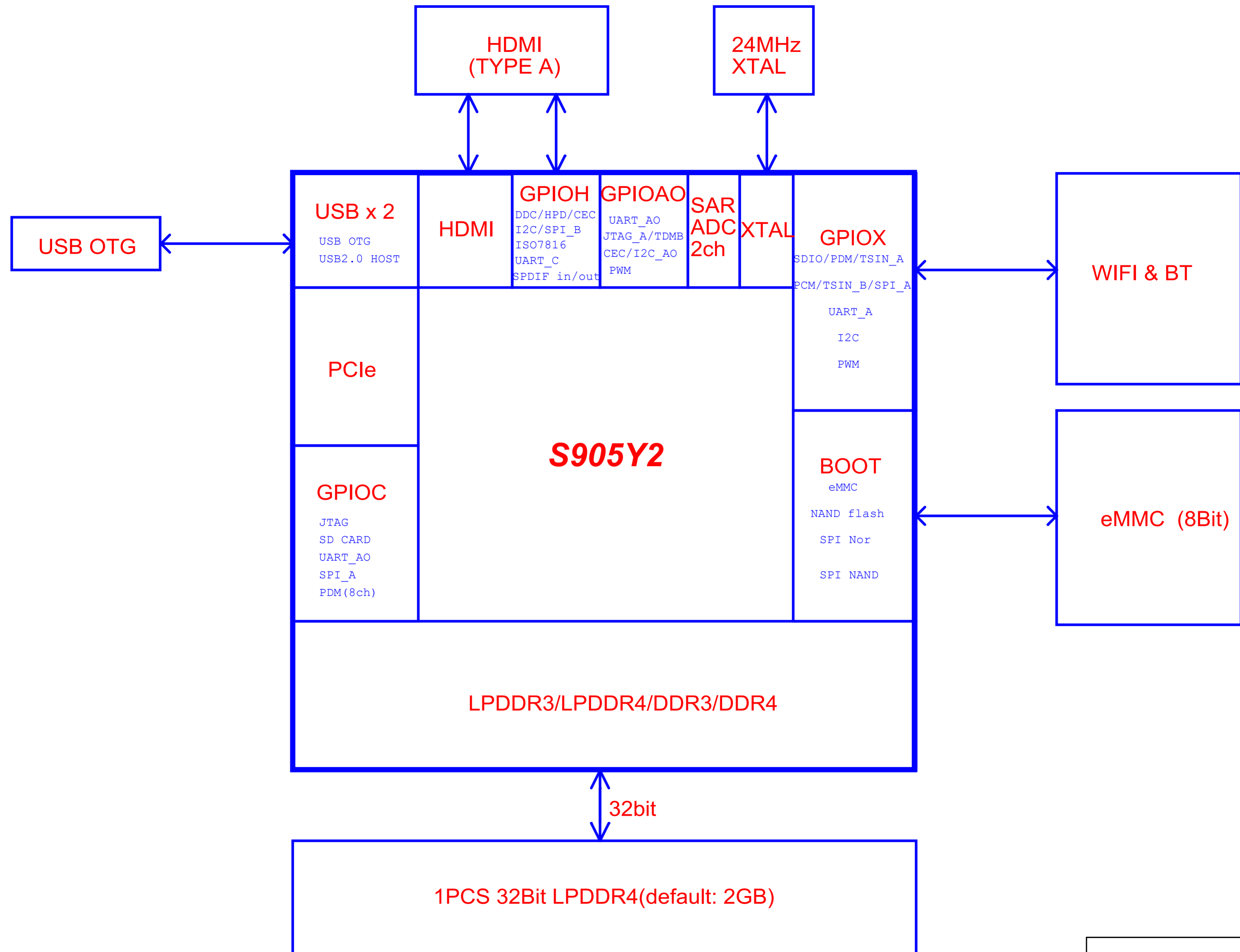

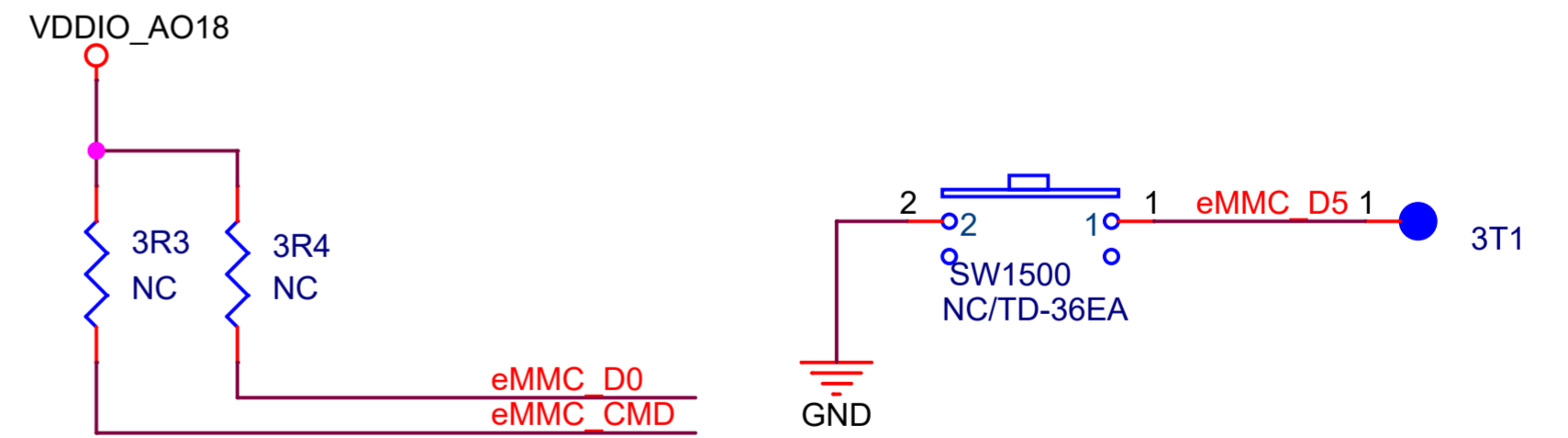
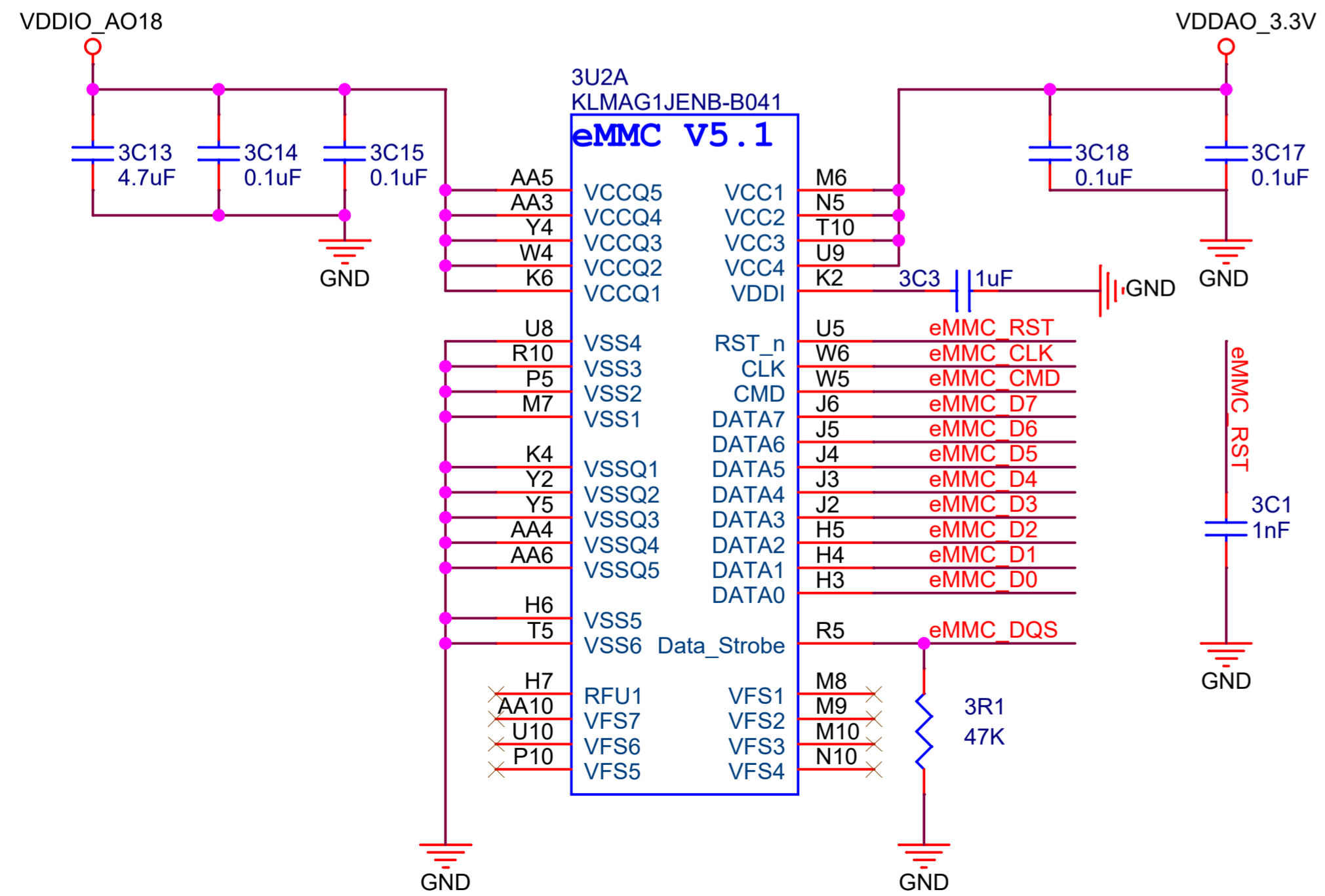
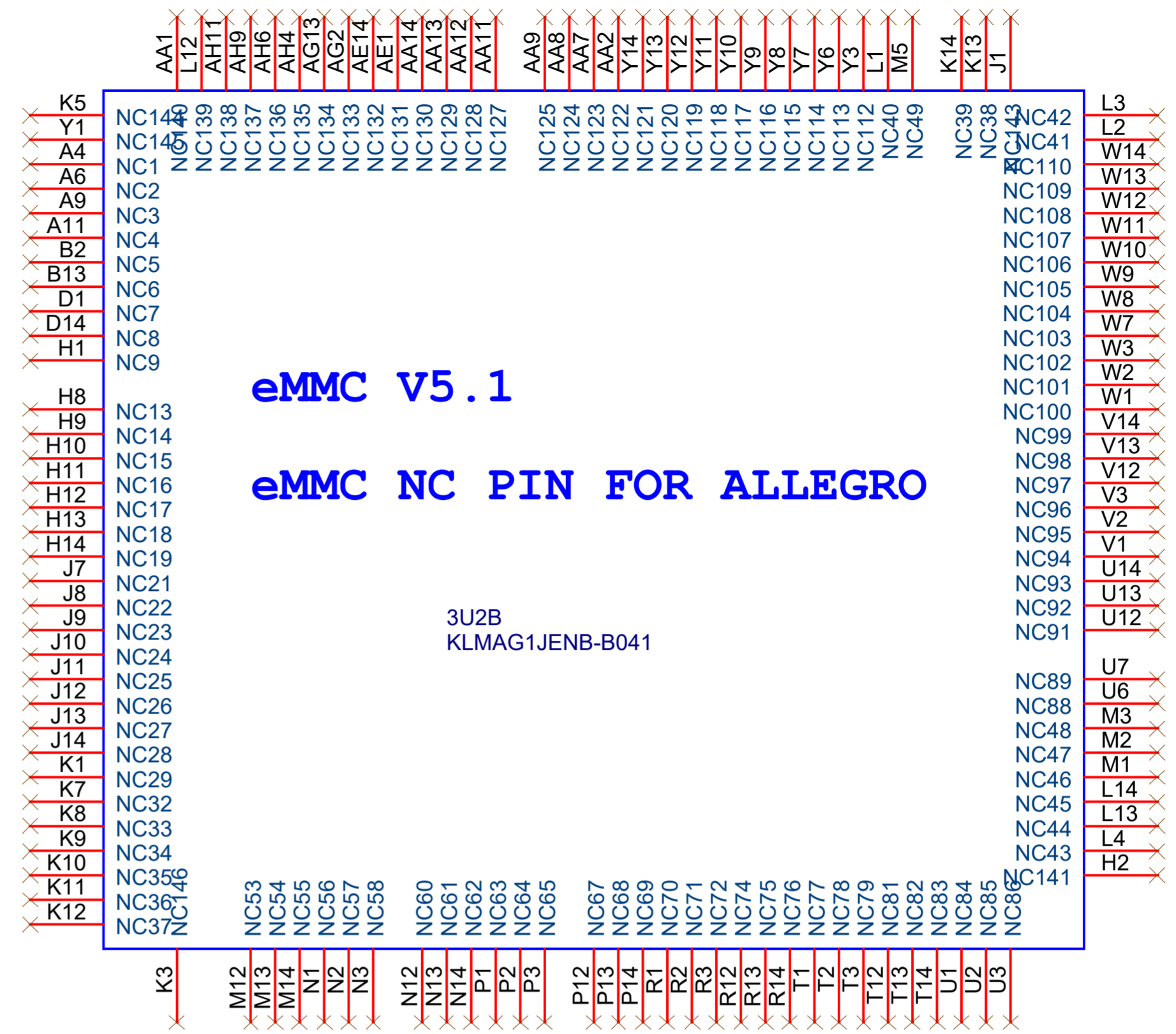
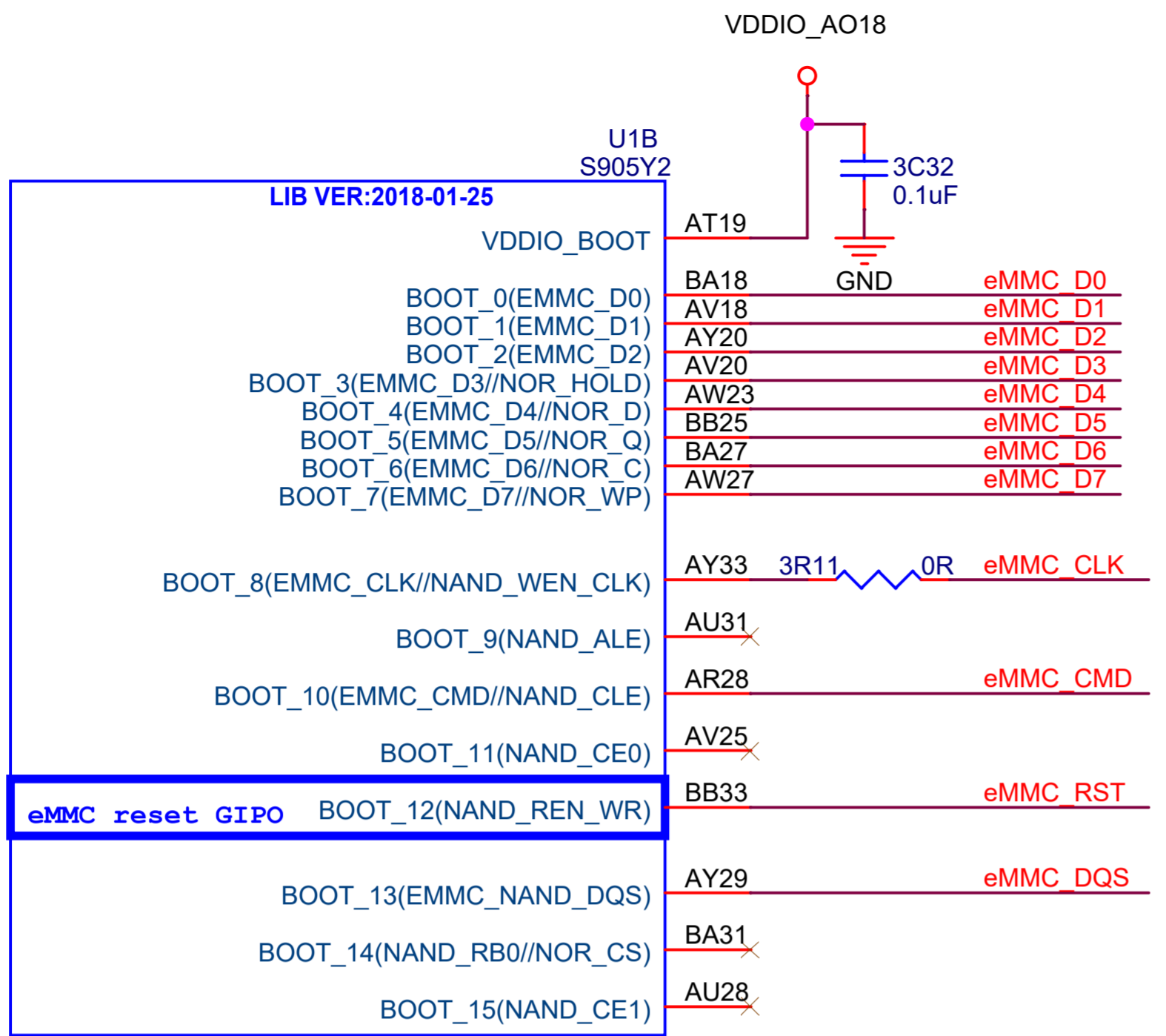

radxa

Size	Title: Radxa ZERO	REV
A4	Page Name: 04.eMMC	1.51
Date: Thursday, May 16, 2024	Sheet 4 of 10	

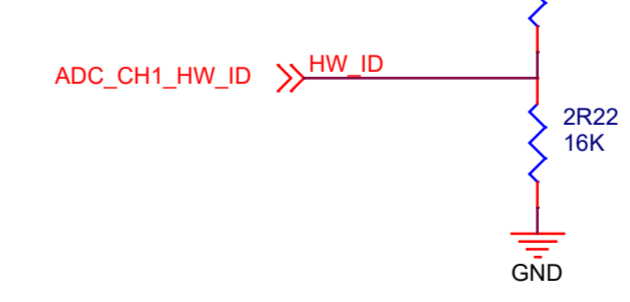
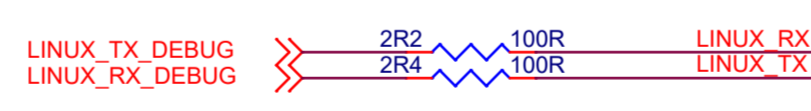
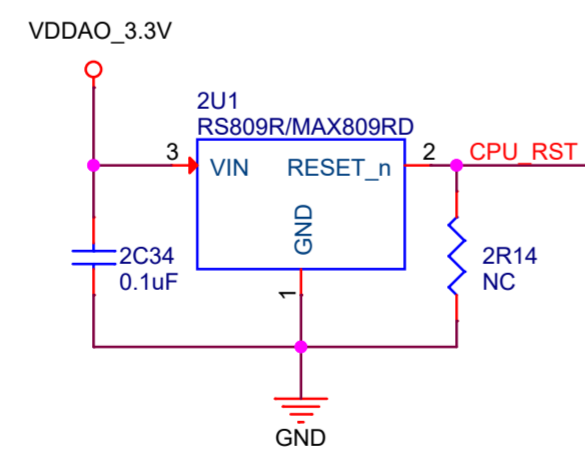
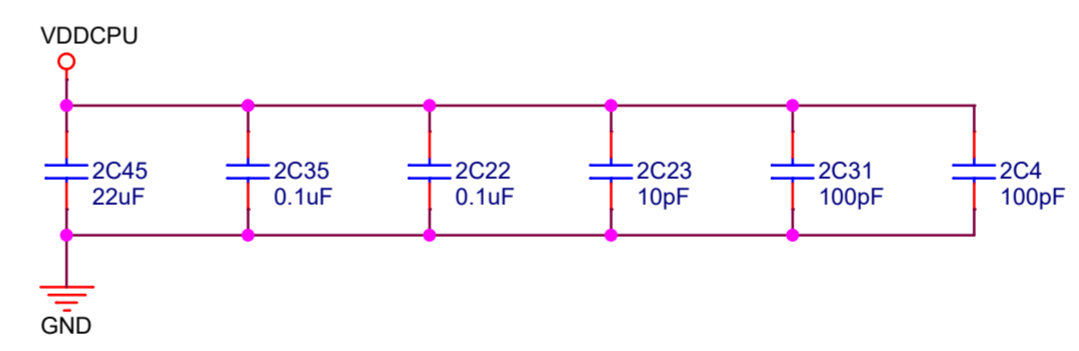
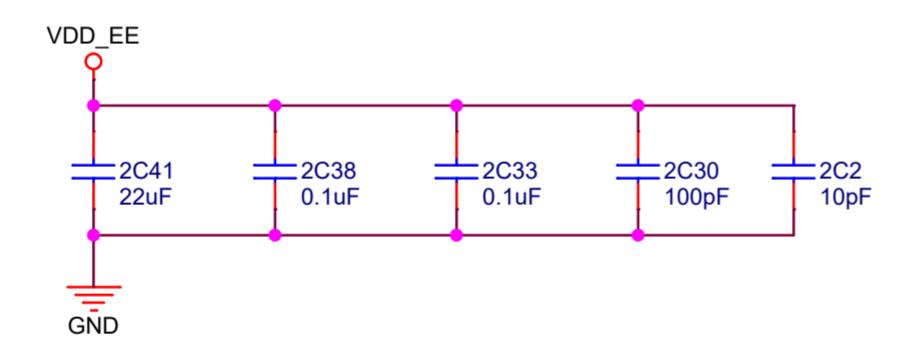
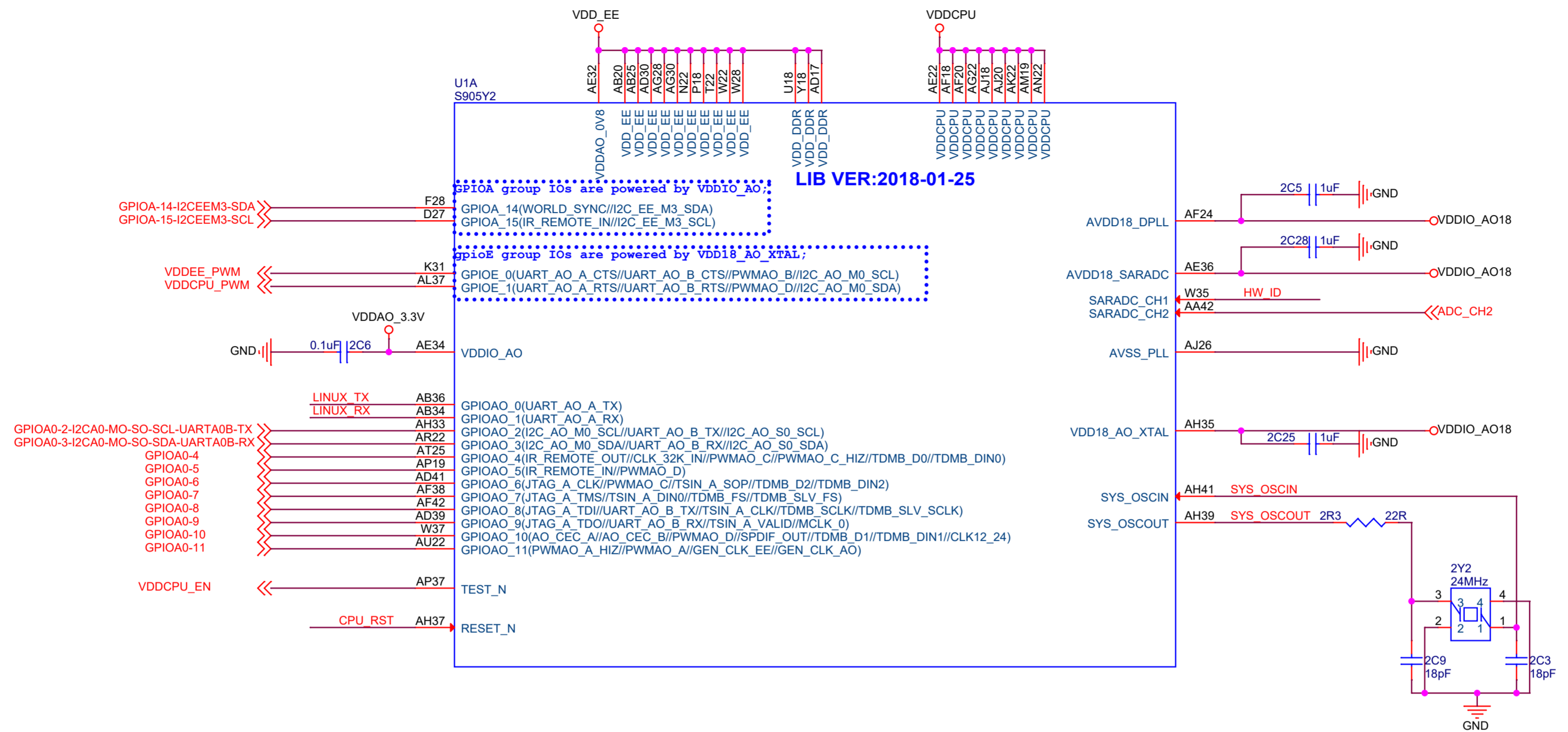

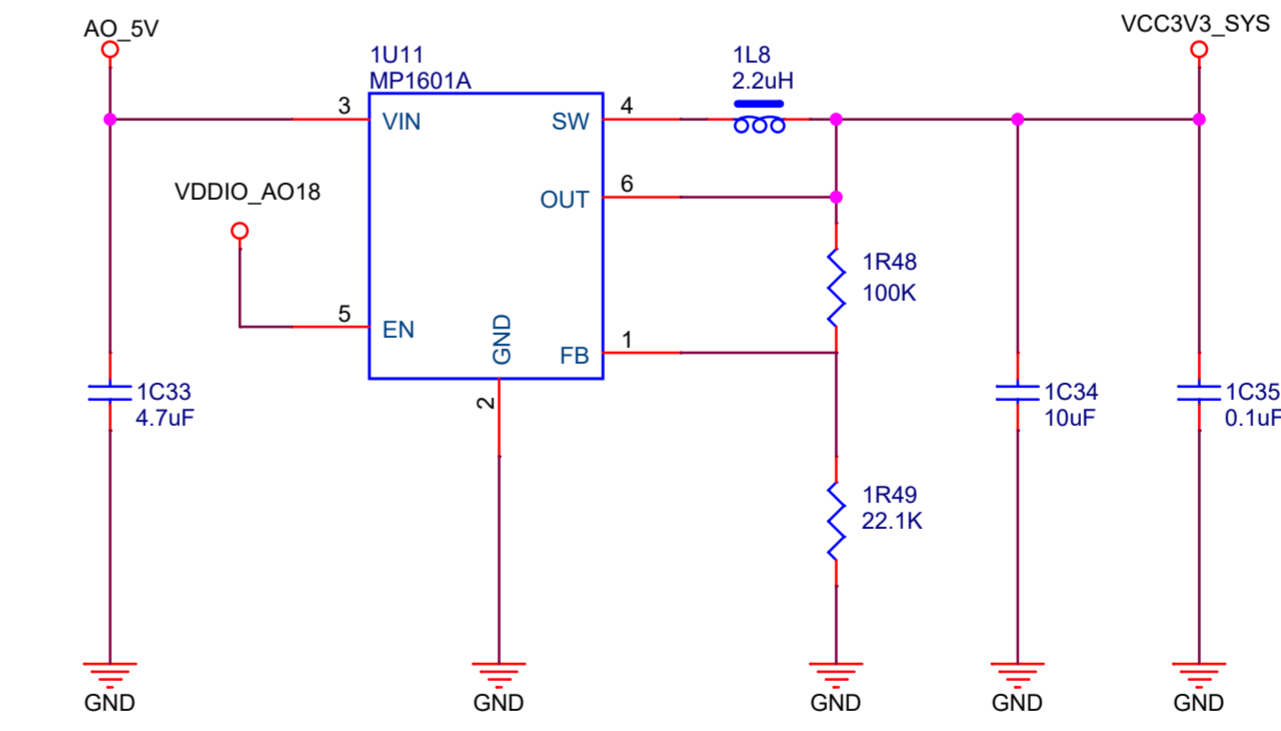
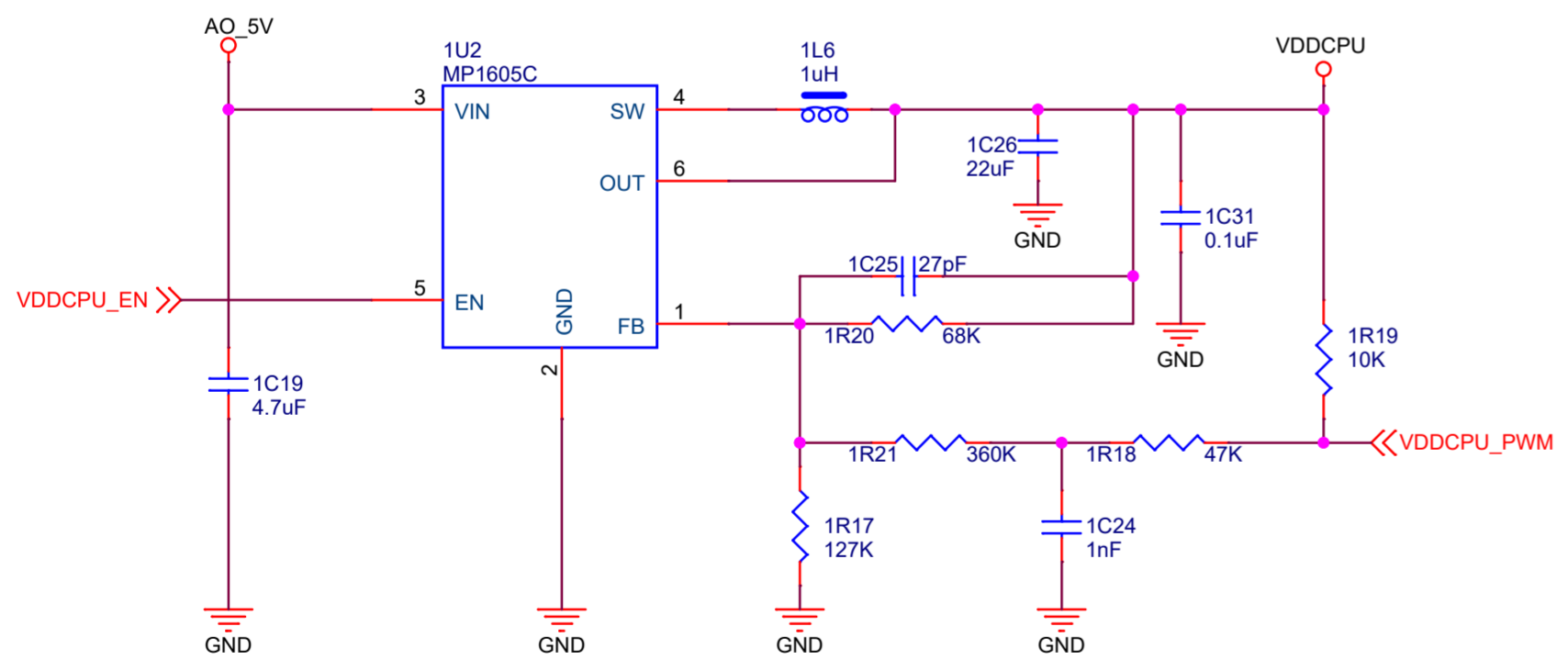
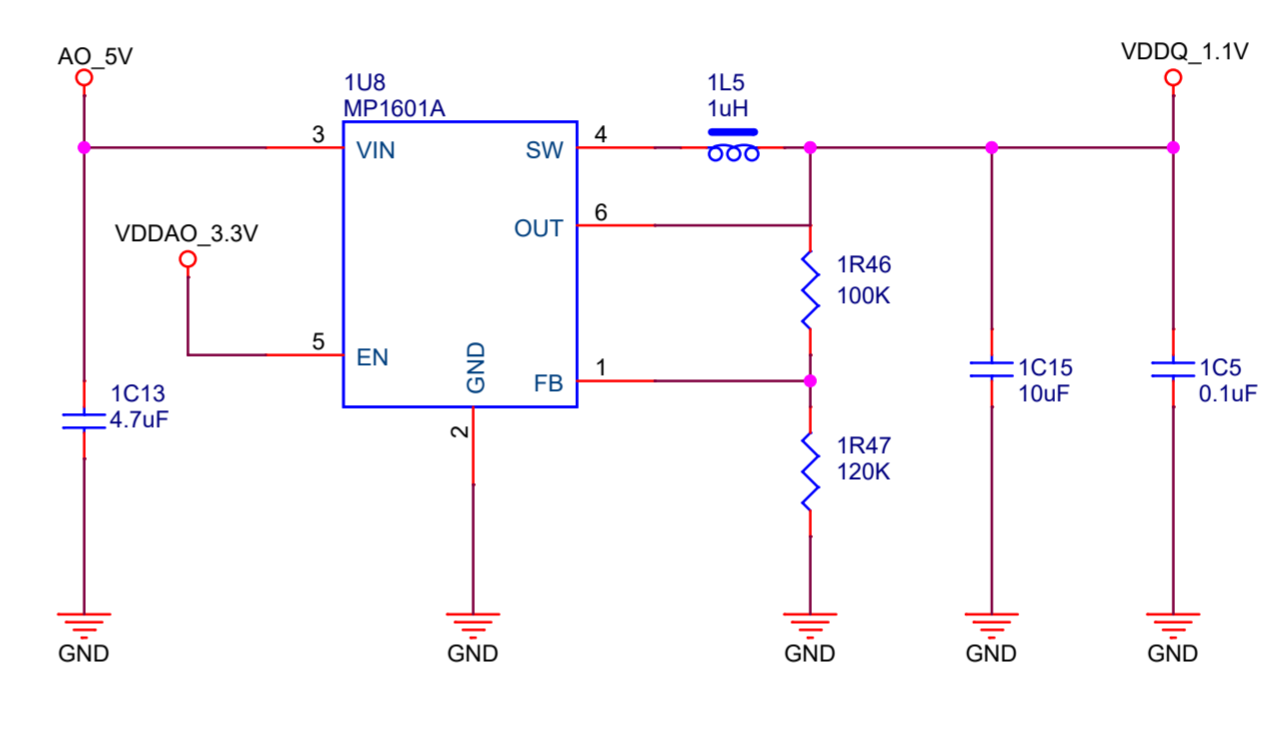
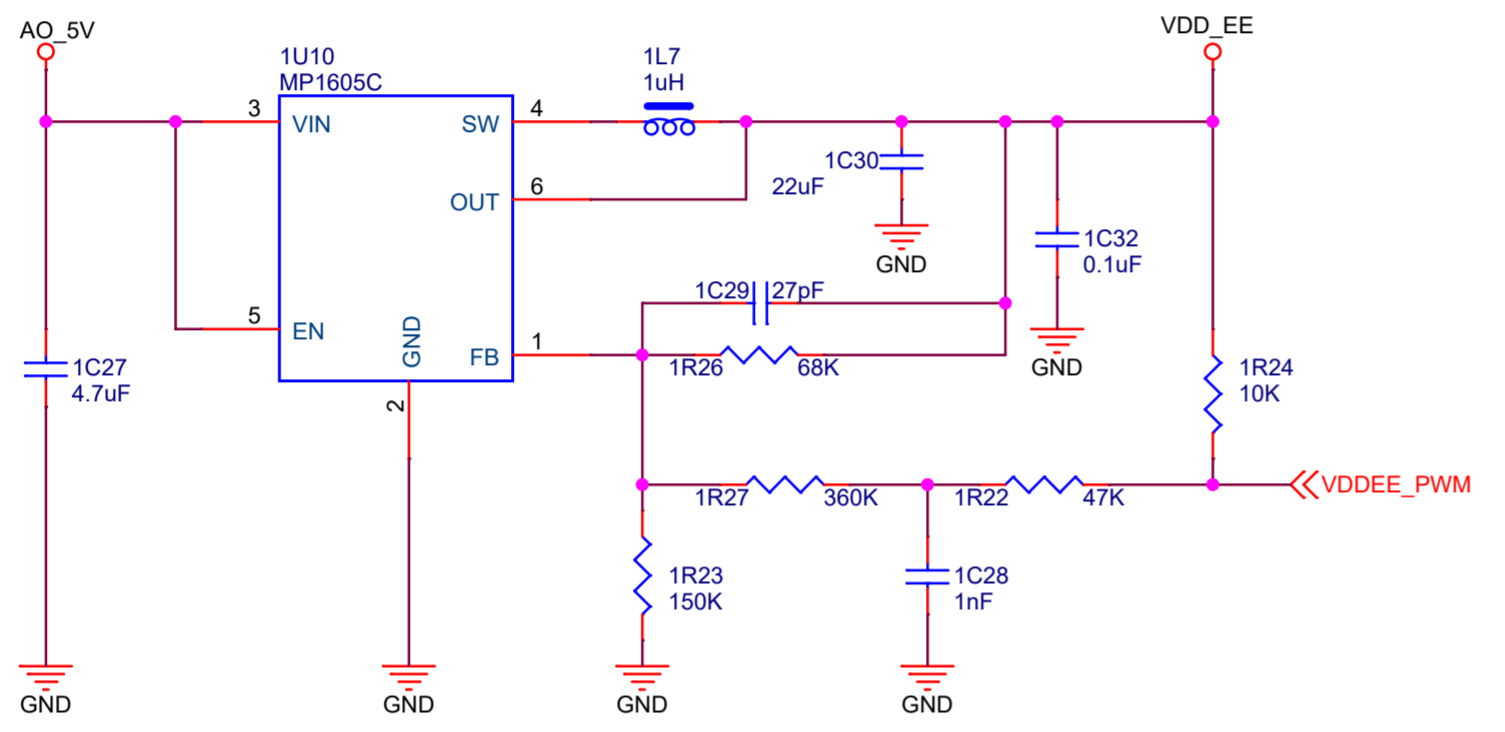
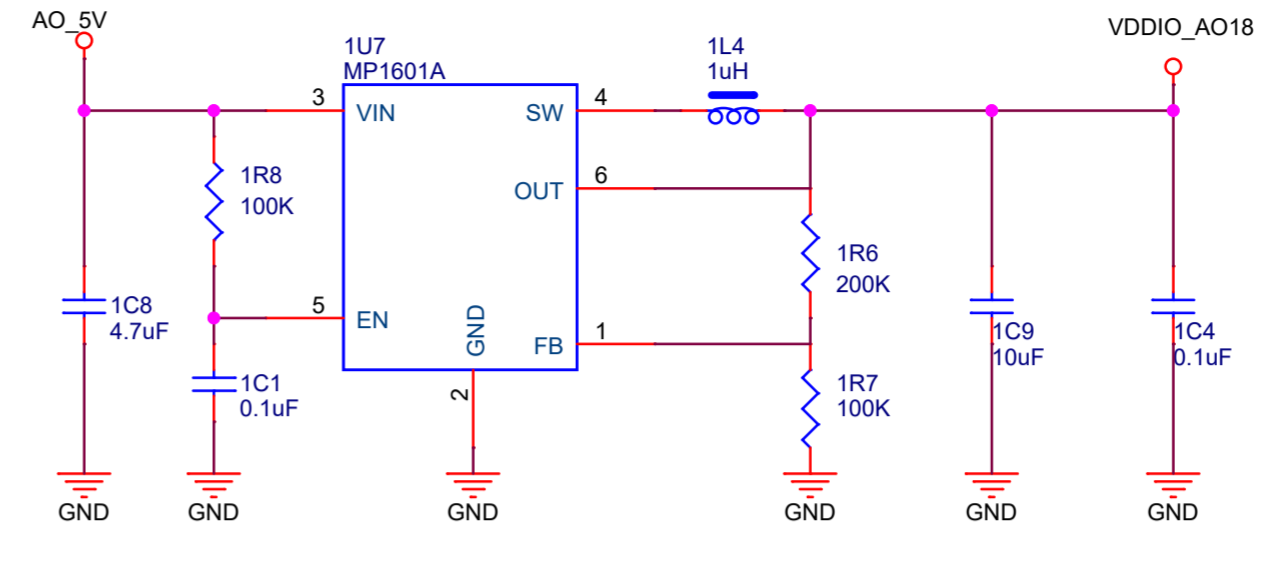
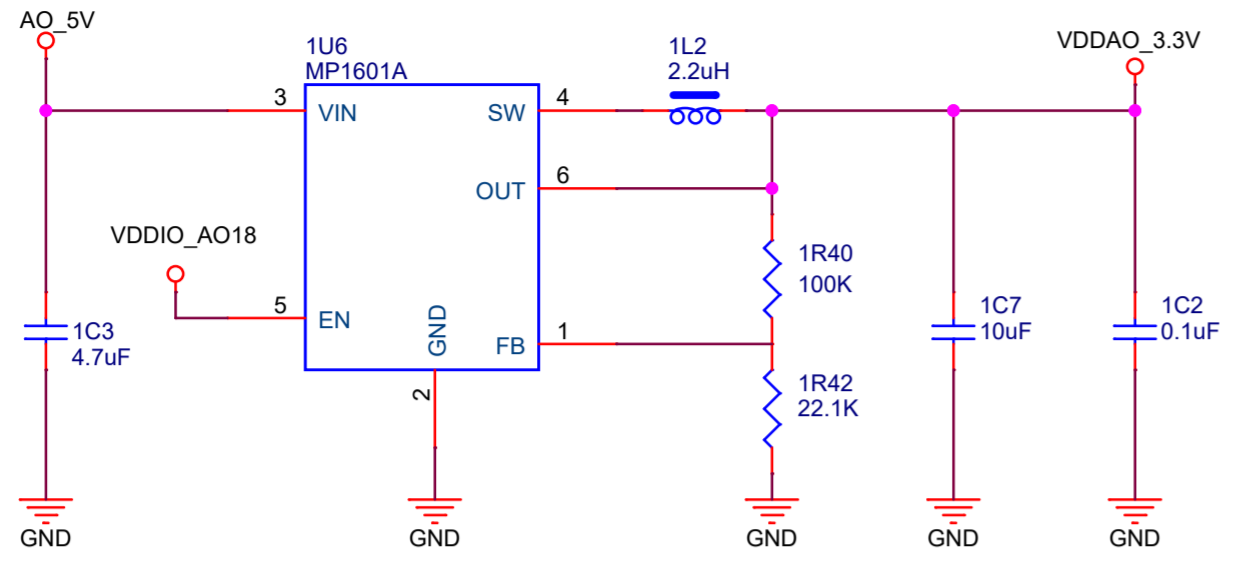

Size	Title: Radxa ZERO	REV
Custom	Page Name: 06.Power	1.51
Date: Thursday, May 16, 2024	Sheet 6 of 10	

