



Radxa ZERO 3W

Schematic

V1.11

Table of Content

- 01.cover
- 02.Index
- 03.Block Diagram
- 04.RK3566_SARADC/GPIO
- 05.RK3566_USB/PCIe/SATA PHY
- 06.RK3566_OSC/PLL/PMUIO
- 07.RK3566_Power/GND
- 08.RK3566_DDR PHY
- 09.RK3566_VI Interface
- 10.RK3566_VO Interface_1
- 11.RK3566_VO Interface_2
- 12.RK3566_Audio Interface
- 13.RK3566_Flash/SD
- 14.LPDDR4_1X32bit
- 15.SPI Flash/eMMC
- 16.MicroSD Card
- 17.TYPEC_USB3.0
- 18.HDMI2.0 TX
- 19.WIFI/BT-SDIO
- 20.CONNECTOR
- 21.Power_PMIC
- 22.Power_DC IN



Size	Title: Zero 3W	REV
A4	Page Name: Index	V1.11
Date:	Thursday, September 21, 2023	Sheet 02 of 22

ROCK 3 Zero W Ref Block Diagram

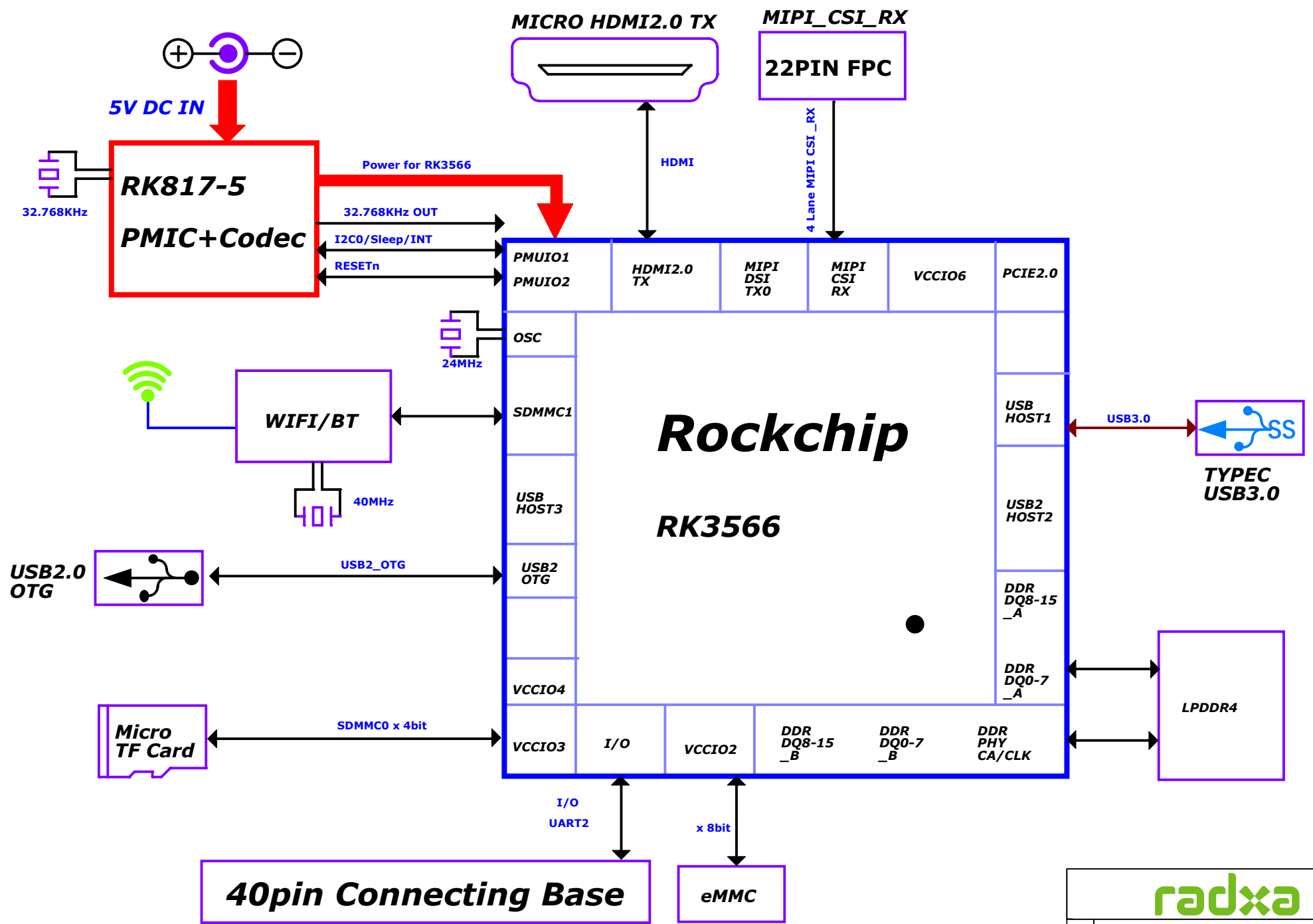

RK3566_K (VCCIO4 Domain)

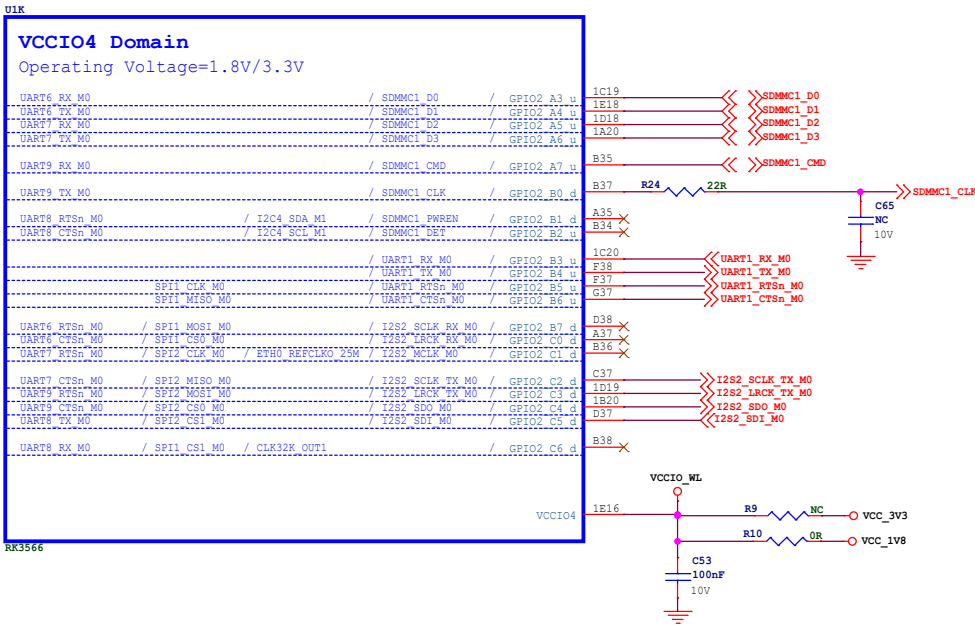

RK3566_O (SARADC/OTP)

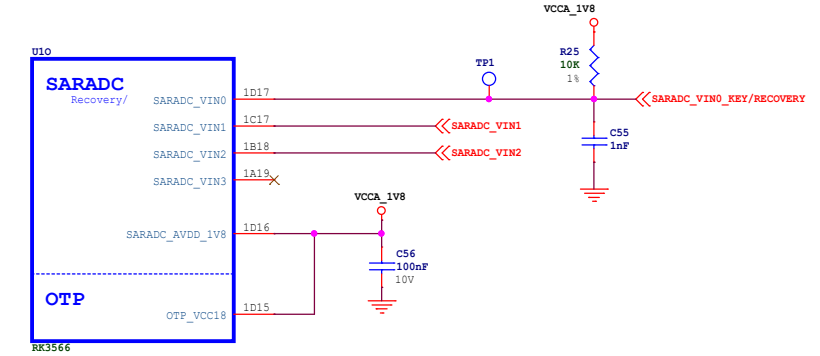

RK3566_N (VCCIO7 Domain)

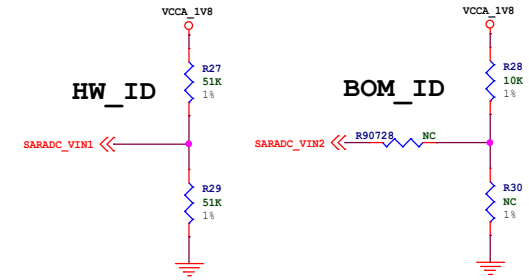
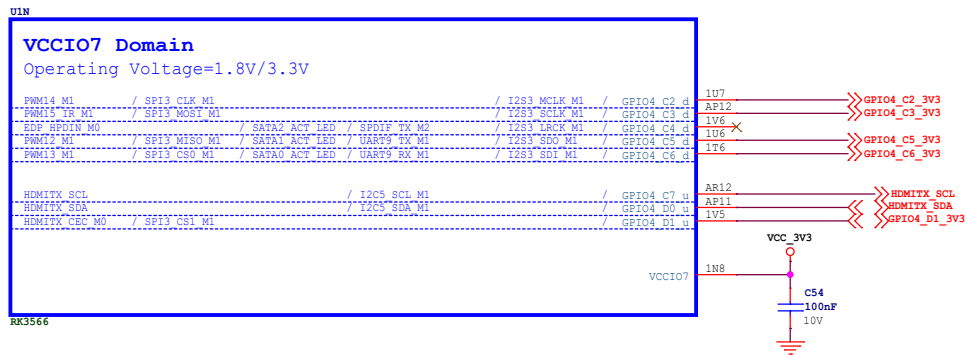

RK3566_U

U1U

USB2.0 OTG_0 HS/FS/LS (Download Port)

USB_OTG0_DP
USB_OTG0_DM
USB_OTG0_VBUSDET
USB_OTG0_ID

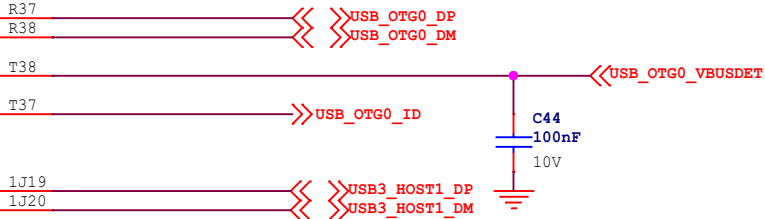

USB2.0 HOST_1 HS/FS/LS (DP/DM for USB3.0 HOST)

USB_HOST1_DP
USB_HOST1_DM



USB2.0 Power (for OTG_0 and HOST_1)

USB_AVDD1_0V9
USB_AVDD1_1V8
USB_AVDD1_3V3

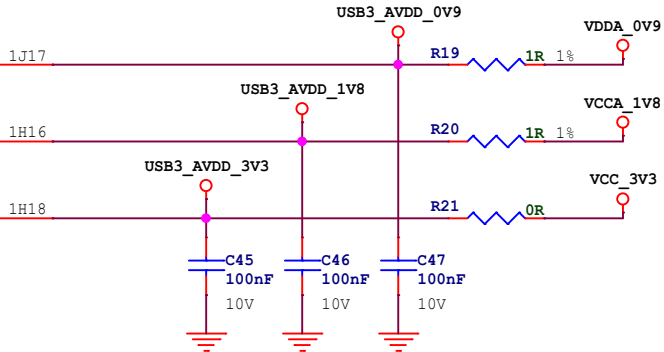

MULTI PHY U_S (SS for USB3.0 HOST or SATA3_1)

USB3_HOST1_SSTXp/SATA1_TXp
USB3_HOST1_SSTXn/SATA1_TXn
USB3_HOST1_SSRXp/SATA1_RXp
USB3_HOST1_SSRXn/SATA1_RXn



MULTI PHY P_S (PCIe2.0 or SATA3_2)

PCIE20_TXp/SATA2_TXp
PCIE20_TXn/SATA2_TXn
PCIE20_RXp/SATA2_RXp
PCIE20_RXn/SATA2_RXn
PCIE20_REFCLKp
PCIE20_REFCLKn

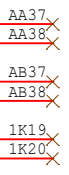

MULTI PHY Power (for MULTI PHY U_S and P_S)

MULTI_PHY_AVDD_0V9
MULTI_PHY_AVDD_1V8

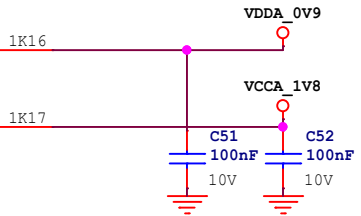

RK3566

RK3566_V

U1V

USB2.0 (for HOST_2 and HOST_3)

USB_HOST2_DP
USB_HOST2_DM
USB_HOST3_DP
USB_HOST3_DM

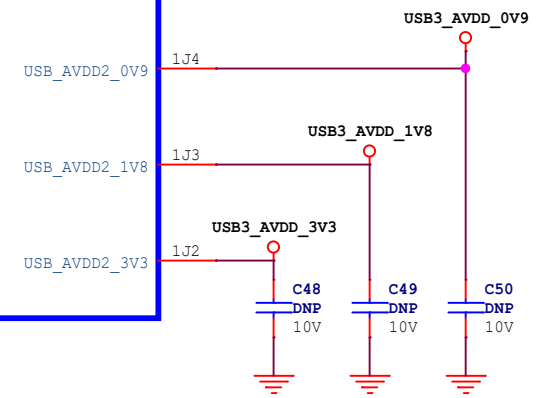
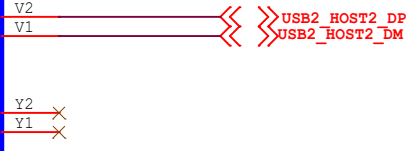

RK3566



Size	Title: Zero 3W	REV
A4	Page Name: RK3566_USB/PCIe/SATA PHY	V1.11
Date: Thursday, September 21, 2023	Sheet 05 of 22	

RK3566 (OSC/PLL/PMUIO1/2)

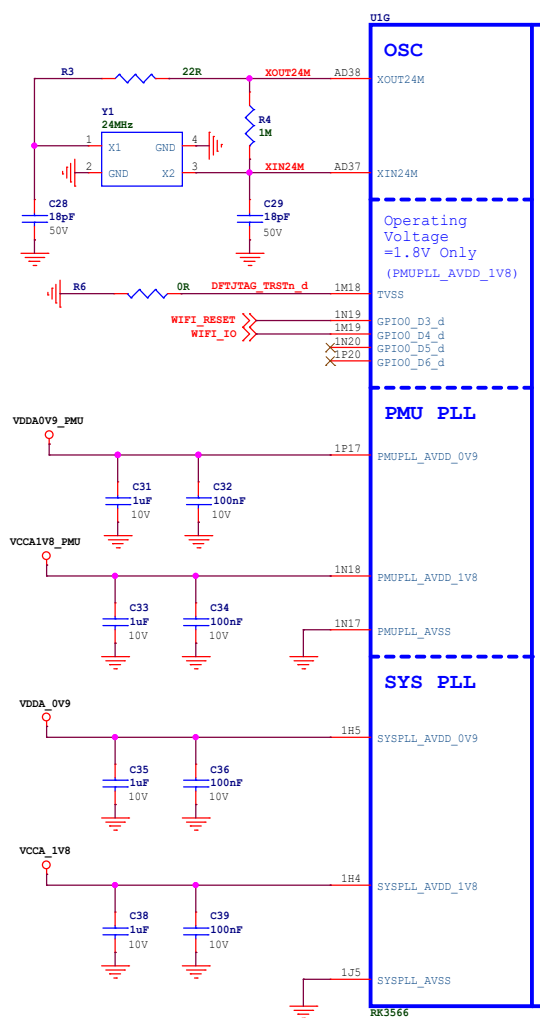

PMUIO1 Domain		PMUIO2 Domain	
Operating Voltage=3.3V Only		Operating Voltage=1.8V/3.3V	
REFCLK_OUT	GPIO0_A0_H	CLK32K_IN	GPIO0_B0_H
TSADC_SHUT_OG0	GPIO0_A1_Z	I2C0_SCL	GPIO0_B1_H
TSADC_SHUT_M0	GPIO0_A2_H	I2C0_SDA	GPIO0_B2_H
PMIC_SLEEP	GPIO0_A3_H	I2C1_SCL	GPIO0_B3_H
SIMMCO_DET	GPIO0_A4_H	I2C1_SDA	GPIO0_B4_H
SIMMCO_PWREN	GPIO0_A5_H	PCIE20_BUTTONST	GPIO0_B5_H
SIMMCO_POD	GPIO0_A6_H	PCIE20_WAREF_M0	GPIO0_B6_H
GPU_PWREN	GPIO0_A7_H	PCIE20_WAREF_M0	GPIO0_B7_H
FLASH_VOL_SEL	GPIO0_A7_H	PCIE20_WAREF_M0	GPIO0_B7_H
GPIO0_A0_H	GPIO0_B0_H	PCIE20_WAREF_M0	GPIO0_B7_H
GPIO0_A1_Z	GPIO0_B1_H	PCIE20_WAREF_M0	GPIO0_B7_H
GPIO0_A2_H	GPIO0_B2_H	PCIE20_WAREF_M0	GPIO0_B7_H
GPIO0_A3_H	GPIO0_B3_H	PCIE20_WAREF_M0	GPIO0_B7_H
GPIO0_A4_H	GPIO0_B4_H	PCIE20_WAREF_M0	GPIO0_B7_H
GPIO0_A5_H	GPIO0_B5_H	PCIE20_WAREF_M0	GPIO0_B7_H
GPIO0_A6_H	GPIO0_B6_H	PCIE20_WAREF_M0	GPIO0_B7_H
GPIO0_A7_H	GPIO0_B7_H	PCIE20_WAREF_M0	GPIO0_B7_H
GPIO0_C0_H	GPIO0_C0_H	PCIE20_WAREF_M0	GPIO0_B7_H
GPIO0_C1_H	GPIO0_C1_H	PCIE20_WAREF_M0	GPIO0_B7_H
GPIO0_C2_H	GPIO0_C2_H	PCIE20_WAREF_M0	GPIO0_B7_H
GPIO0_C3_H	GPIO0_C3_H	PCIE20_WAREF_M0	GPIO0_B7_H
GPIO0_C4_H	GPIO0_C4_H	PCIE20_WAREF_M0	GPIO0_B7_H
GPIO0_C5_H	GPIO0_C5_H	PCIE20_WAREF_M0	GPIO0_B7_H
GPIO0_C6_H	GPIO0_C6_H	PCIE20_WAREF_M0	GPIO0_B7_H
GPIO0_C7_H	GPIO0_C7_H	PCIE20_WAREF_M0	GPIO0_B7_H
GPIO0_D0_H	GPIO0_D0_H	PCIE20_WAREF_M0	GPIO0_B7_H
GPIO0_D1_H	GPIO0_D1_H	PCIE20_WAREF_M0	GPIO0_B7_H

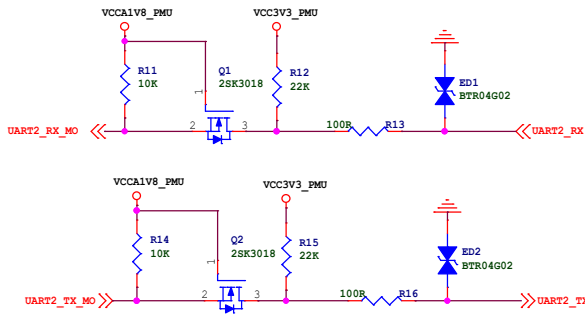
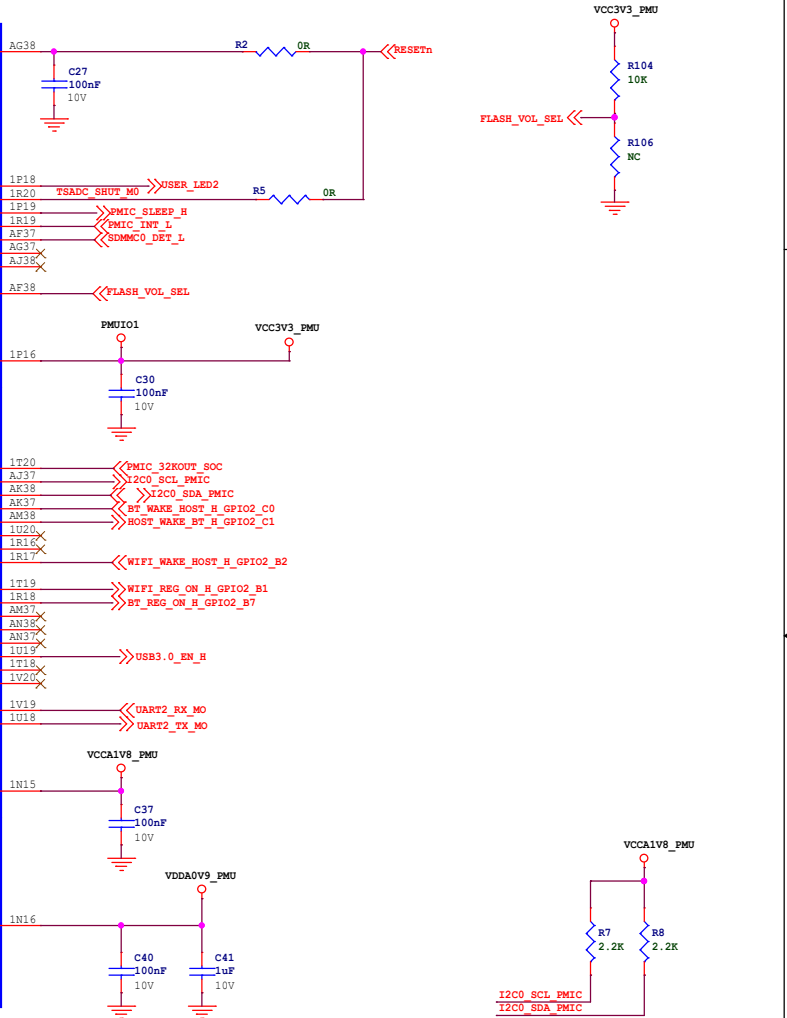

RK3566_ABCDE (Power&GND)

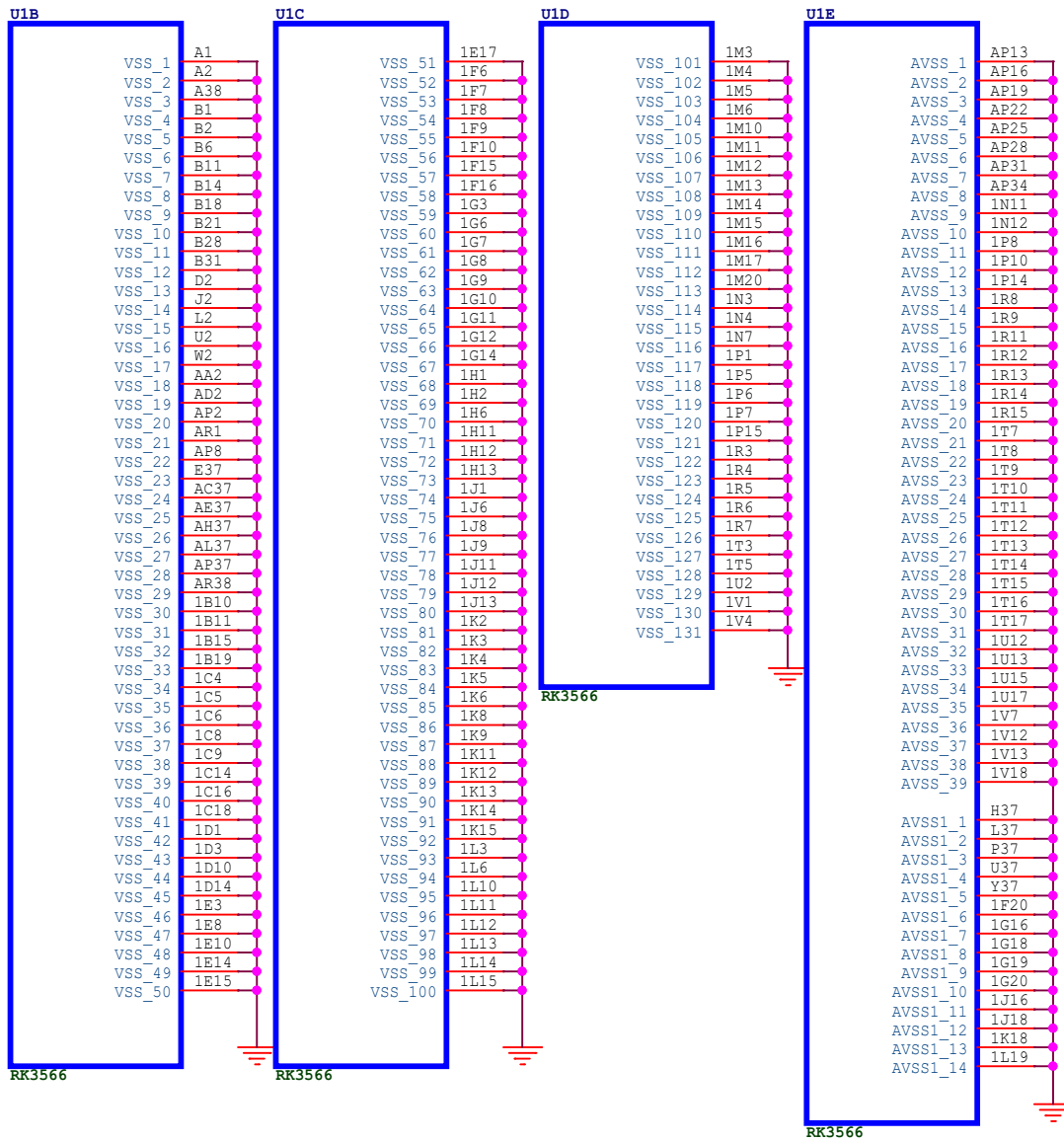
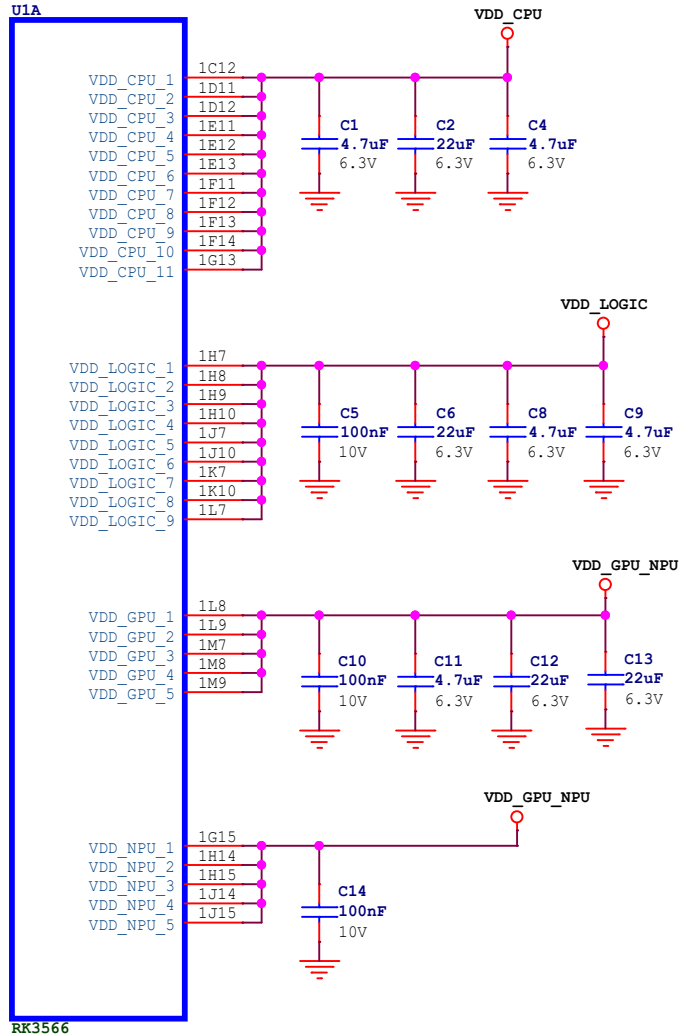

RK3566_F (DDR PHY)

UIF

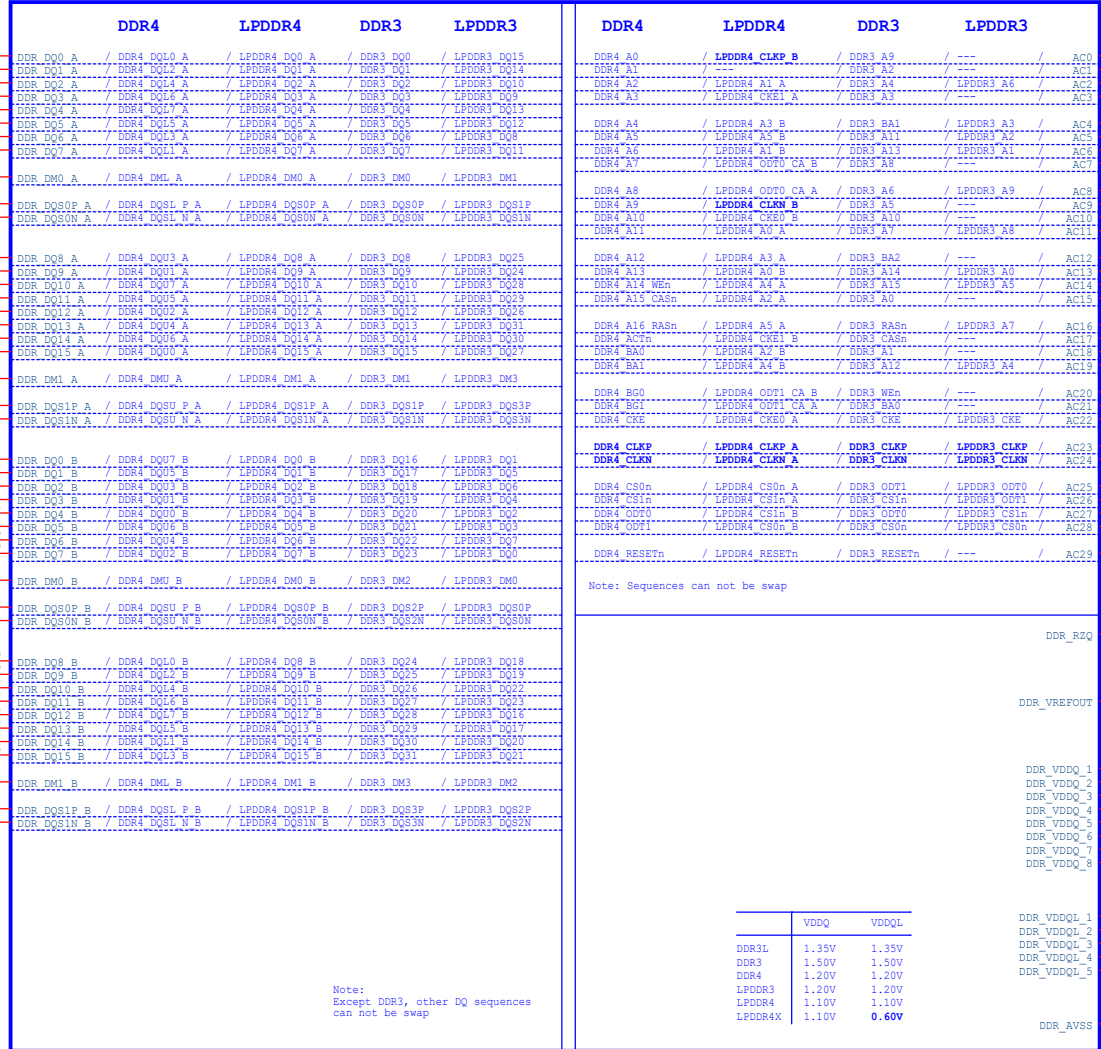

Note:
Except DDR3, other DQ sequences
can not be swap

RK3566

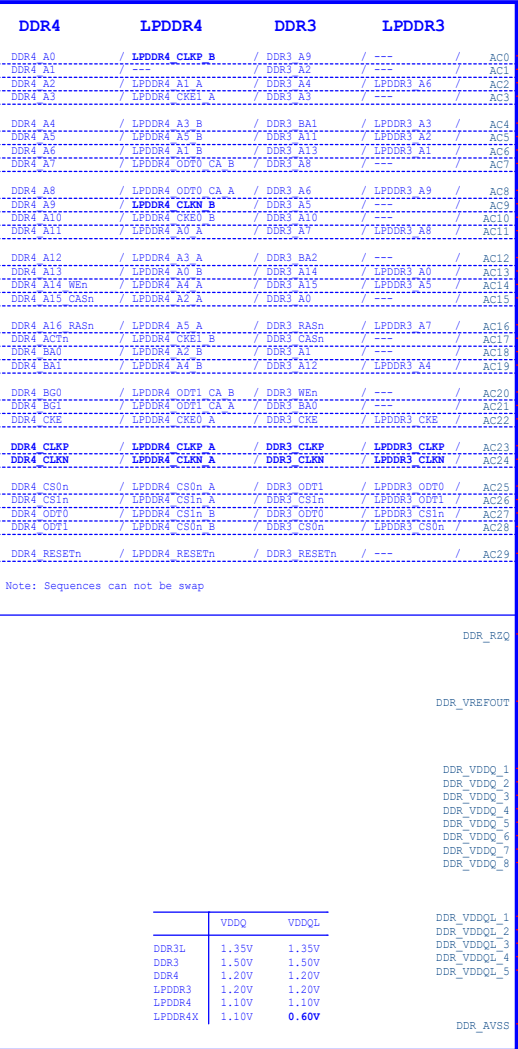

Note: Sequences can not be swap

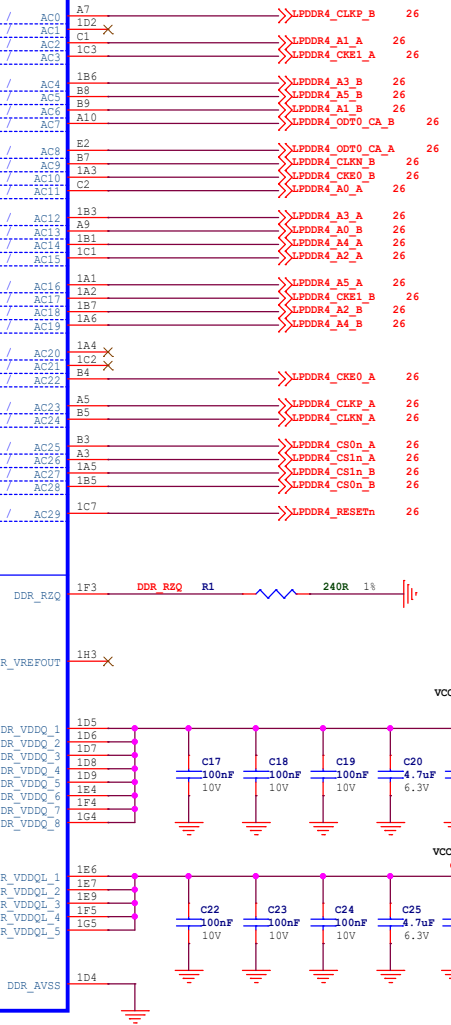

	VDDQ	VDDQL
DDR3L	1.35V	1.35V
DDR3	1.50V	1.50V
DDR4	1.20V	1.20V
LPDDR3	1.20V	1.20V
LPDDR4	1.10V	1.10V
LPDDR4X	1.10V	0.60V



RK3566_P (MIPI_CSI_RX)

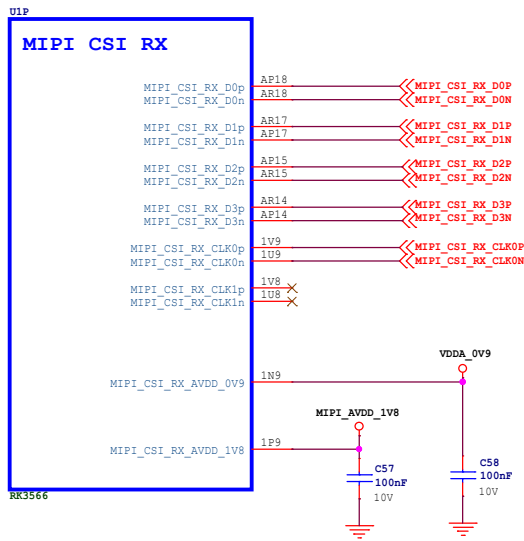

MIPI_CSI_RX 4Lanes

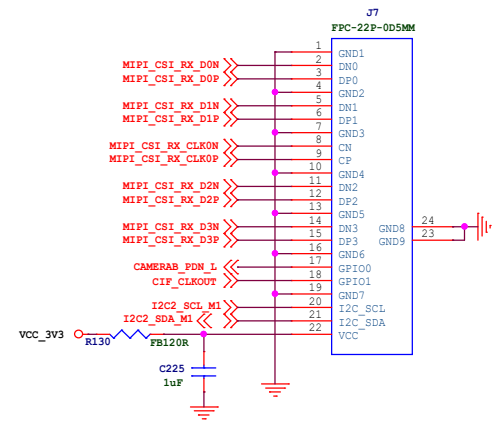

RK3566_M (VCCIO6 Domain)

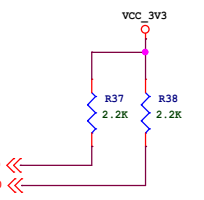
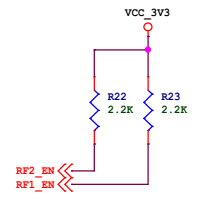
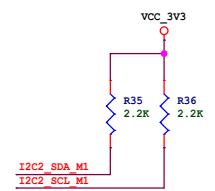
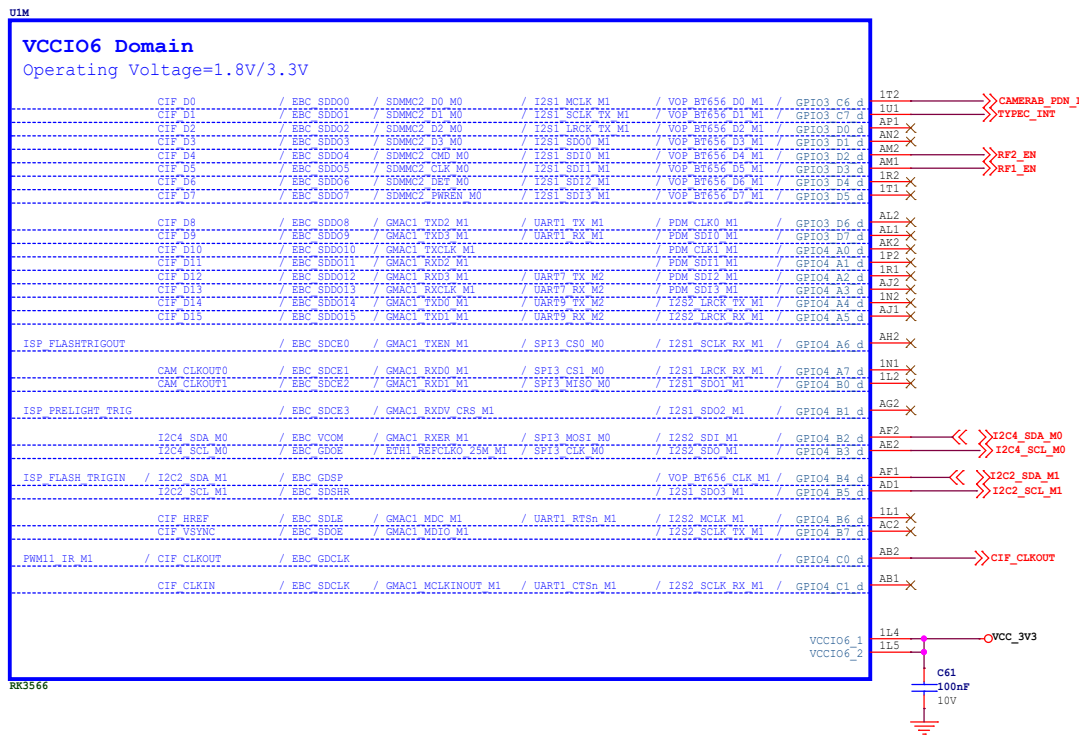

RK3566_R (MIPI_DSI_TX0/LVDS_TX0)

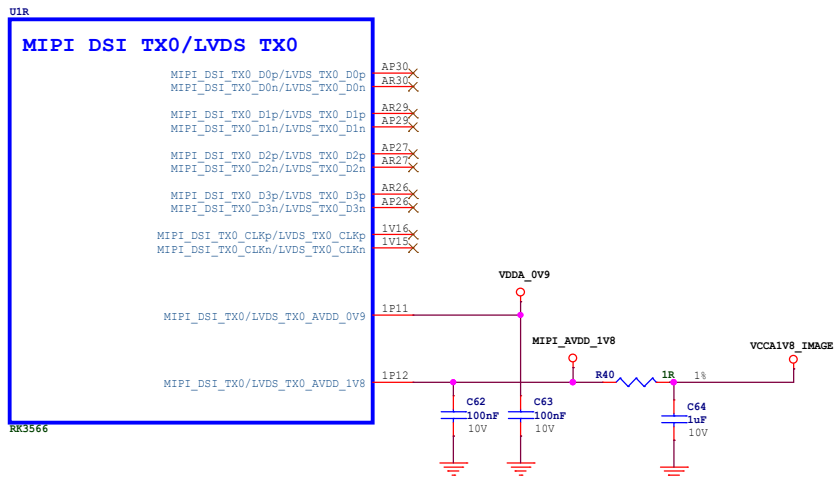

RK3566_S (MIPI_DSI_TX1/LVDS_TX1)

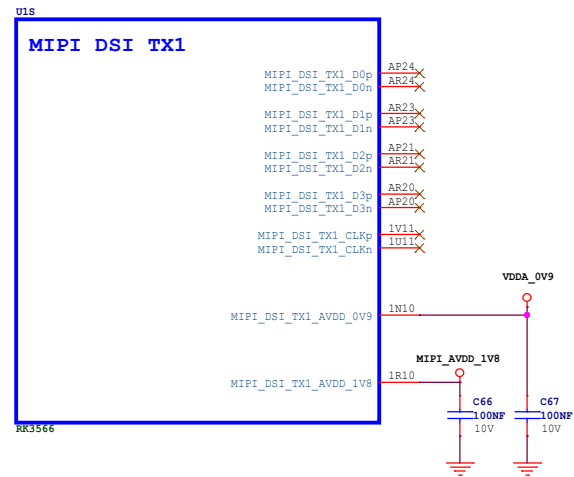

RK3566_T (eDP/DP TX)

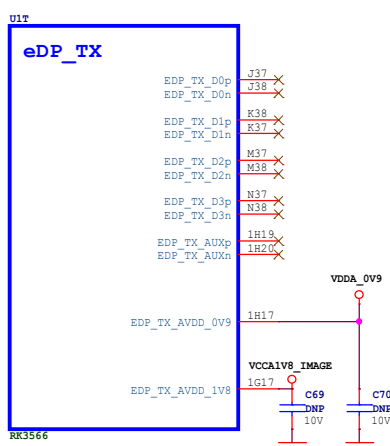

RK3566_Q (HDMI2.0 TX)

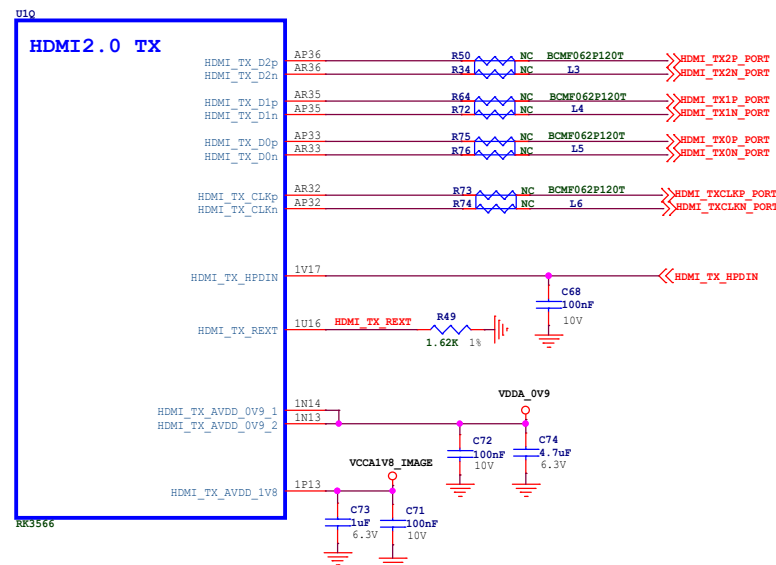

RK3566_L (VCCIO5 Domain)

U1L

VCCIO5 Domain

Operating Voltage=1.8V/3.3V

VOP BT1120 D0	/ SPI1 CS0 M1			/ SDMMC2 D0 M1	/ GPIO3 A1 d	1U5	>> GPIO3_A1_3V3
VOP BT1120 D1		/ GMAC1 TXD2 M0	/ I2S3 MCLK M0	/ SDMMC2 D1 M1	/ GPIO3 A2 d	AR10	>> GPIO3_A2_3V3
VOP BT1120 D2		/ GMAC1 TXD3 M0	/ I2S3 SCLK M0	/ SDMMC2 D2 M1	/ GPIO3 A3 d	AP10	>> GPIO3_A3_3V3
VOP BT1120 D3		/ GMAC1 RXD2 M0	/ I2S3 LRCK M0	/ SDMMC2 D3 M1	/ GPIO3 A4 d	AR9	>> GPIO3_A4_3V3
VOP BT1120 D4		/ GMAC1 RXD3 M0	/ I2S3 SDO M0	/ SDMMC2 CMD M1	/ GPIO3 A5 d	AP9	>> GPIO3_A5_3V3
VOP BT1120 CLK		/ GMAC1 TXCLK M0	/ I2S3 SDI M0	/ SDMMC2 CLK M1	/ GPIO3 A6 d	1U4	>> GPIO3_A6_3V3
VOP BT1120 D5		/ GMAC1 RXCLK M0		/ SDMMC2 DET M1	/ GPIO3 A7 d	1V3	>> GPIO3_A7_3V3
VOP BT1120 D6		/ ETH1 REFCLK0 25M M0		/ SDMMC2 PWREN M1	/ GPIO3 B0 d	AR7	>> GPIO3_B0_3V3
PWM8 M0	/ VOP BT1120 D7	/ GMAC1 RXD0 M0	/ UART4 RX M1		/ GPIO3 B1 d	AP7	>> GPIO3_B1_3V3
PWM9 M0	/ VOP BT1120 D8	/ GMAC1 RXD1 M0	/ UART4 TX M1		/ GPIO3 B2 d	AR6	>> GPIO3_B2_3V3
VOP BT1120 D9	/ I2C5 SCL M0	/ GMAC1 RXDV CRS M0		/ PDM SDI0 M2	/ GPIO3 B3 d	AP6	>> GPIO3_B3_3V3
VOP BT1120 D10	/ I2C5 SDA M0	/ GMAC1 RXER M0		/ PDM SDI1 M2	/ GPIO3 B4 d	1U3	>> GPIO3_B4_3V3
PWM10 M0	/ VOP BT1120 D11	/ I2C3 SCL M1	/ GMAC1 TXD0 M0		/ GPIO3 B5 d	1T4	>> I2C3_SCL_M1
PWM11 IR M0	/ VOP BT1120 D12	/ I2C3 SDA M1	/ GMAC1 TXD1 M0		/ GPIO3 B6 d	1V2	>> I2C3_SDA_M1
PWM12 M0		/ GMAC1 TXEN M0	/ UART3 TX M1	/ PDM SDI2 M2	/ GPIO3 B7 d	AP5	>> GMAC1_INT/FMEB_GPIO3_B7
PWM13 M0		/ GMAC1 MCLKINOUT M0	/ UART3 RX M1	/ PDM SDI3 M2	/ GPIO3 C0 d	AR4	>> GMAC1_RSTn_GPIO3_C0
VOP BT1120 D13	/ SPI1 MOSI M1		/ PCIE20 PERStn M1	/ I2S1 SDO2 M2	/ GPIO3 C1 d	AP4	>> GPIO3_C1_3V3
VOP BT1120 D14	/ SPI1 MISO M1		/ UART5 TX M1	/ I2S1 SDO3 M2	/ GPIO3 C2 d	AP3	>> GPIO3_C2_3V3
VOP BT1120 D15	/ SPI1 CLK M1		/ UART5 RX M1	/ I2S1 SCLK RX M2	/ GPIO3 C3 d	AR2	>> GPIO3_C3_3V3
PWM14 M0	/ VOP PWM M1	/ GMAC1 MDC M0	/ UART7 TX M1	/ PDM CLK1 M2	/ GPIO3 C4 d	1P3	>> GPIO3_C4_3V3
PWM15 IR M0	/ SPDIF TX M1	/ GMAC1 MDIO M0	/ UART7 RX M1	/ I2S1 LRCK RX M2	/ GPIO3 C5 d	1P4	>> GPIO3_C5_3V3

RK3566

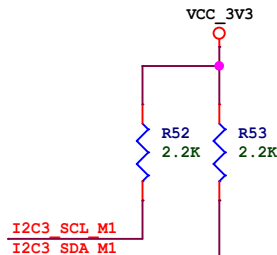
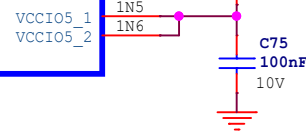

Size	Title: Zero 3W	REV
A4	Page Name: RK3566_VO Interface_2	V1.11
Date: Thursday, September 21, 2023 Sheet 11 of 22		

RK3566_H (VCCIO1 Domain)

U1H

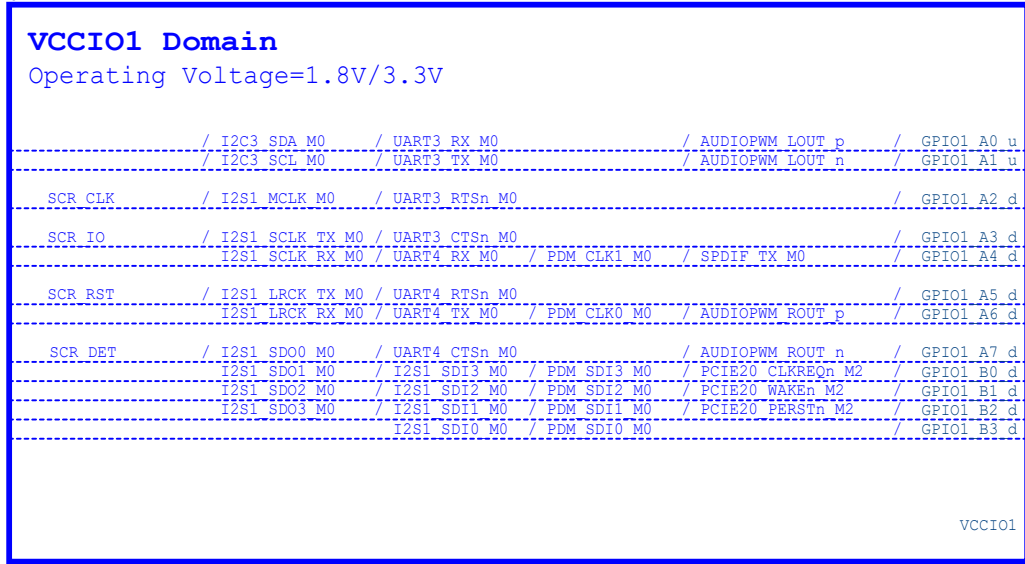

RK3566

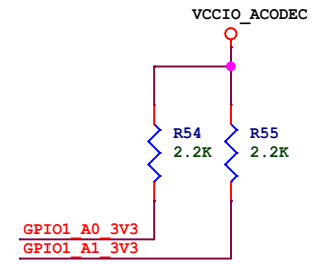
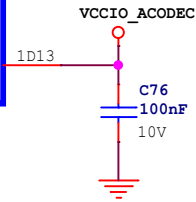
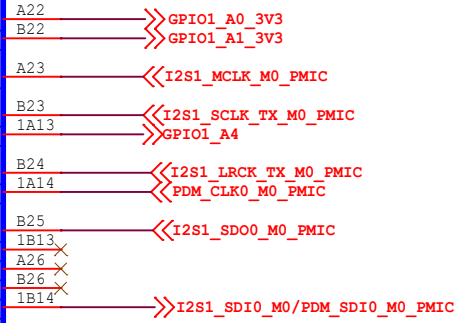

Size	Title: Zero 3W	REV
A4	Page Name: RK3566_Audio Interface	V1.11
Date: Thursday, September 21, 2023	Sheet 12 of 22	

RK3566_I (VCCIO2 Domain)

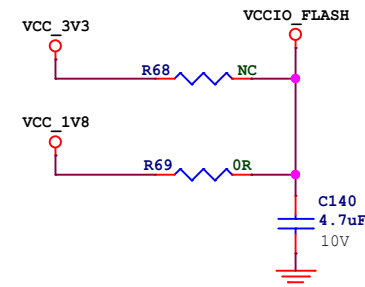
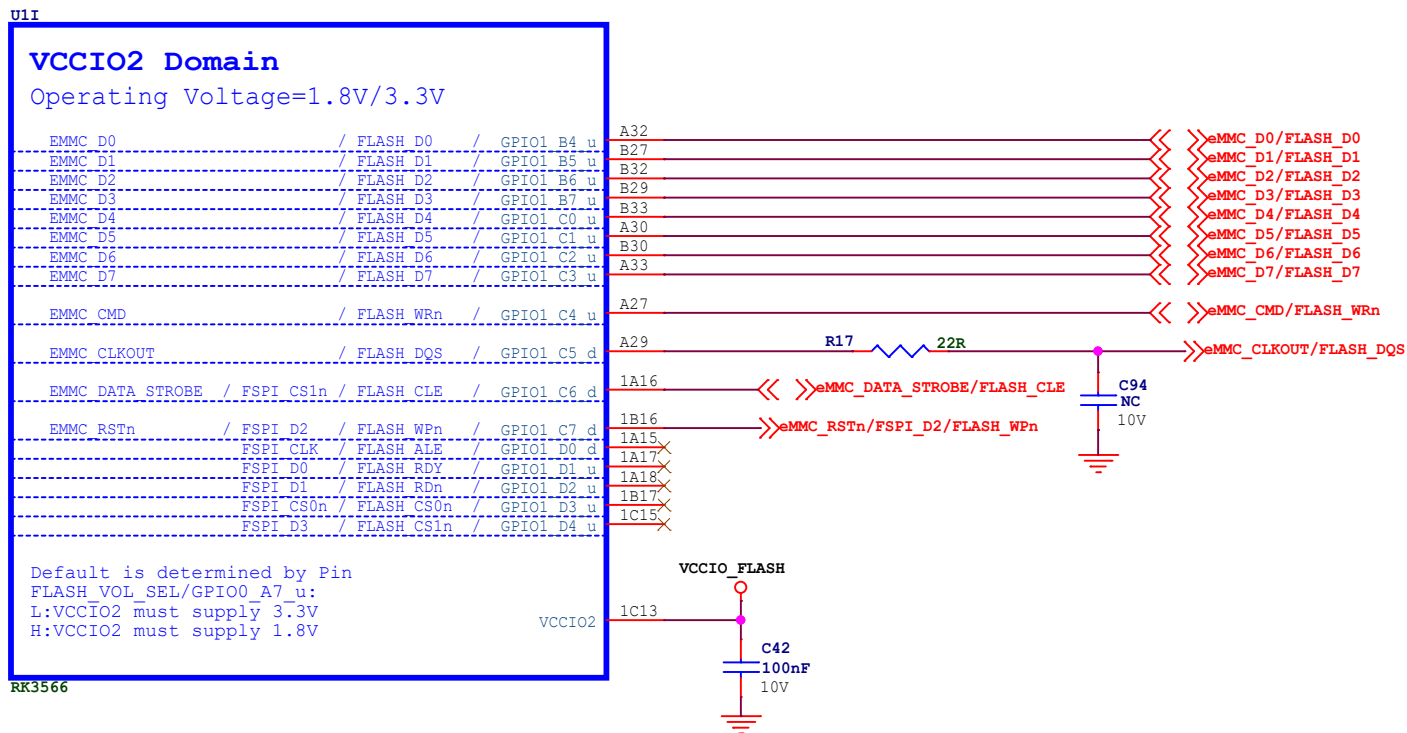

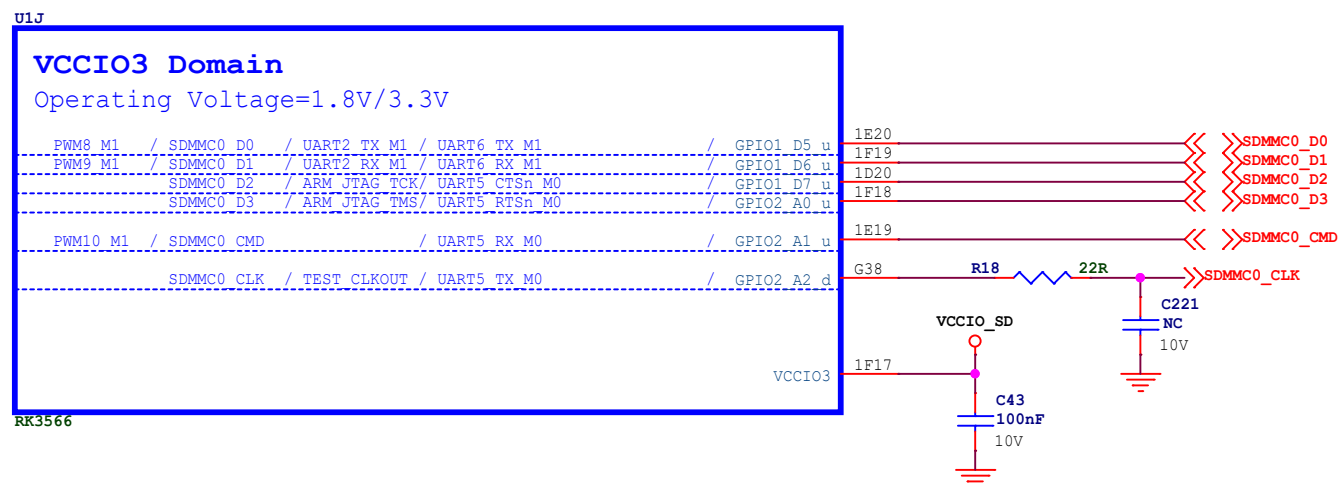

RK3566_J (VCCIO3 Domain)

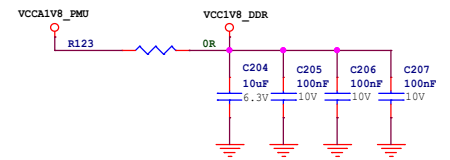
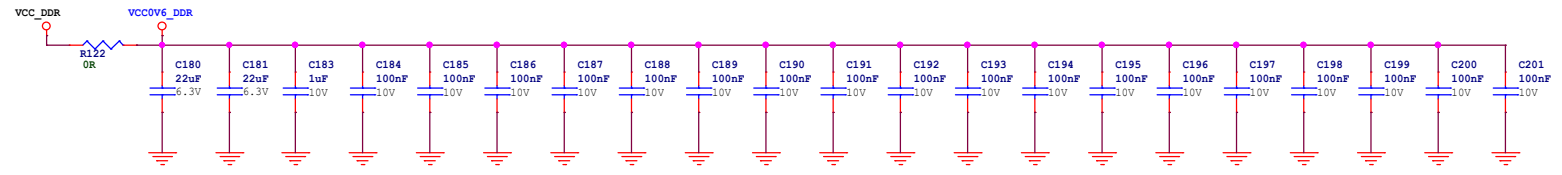
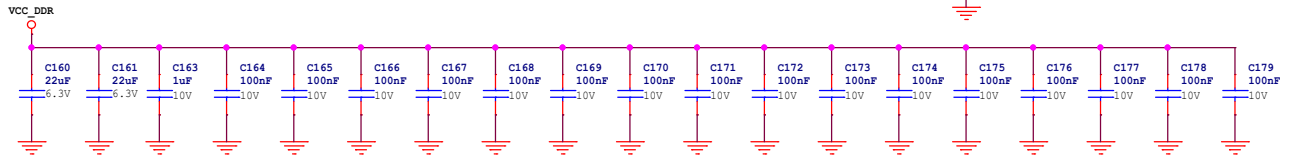
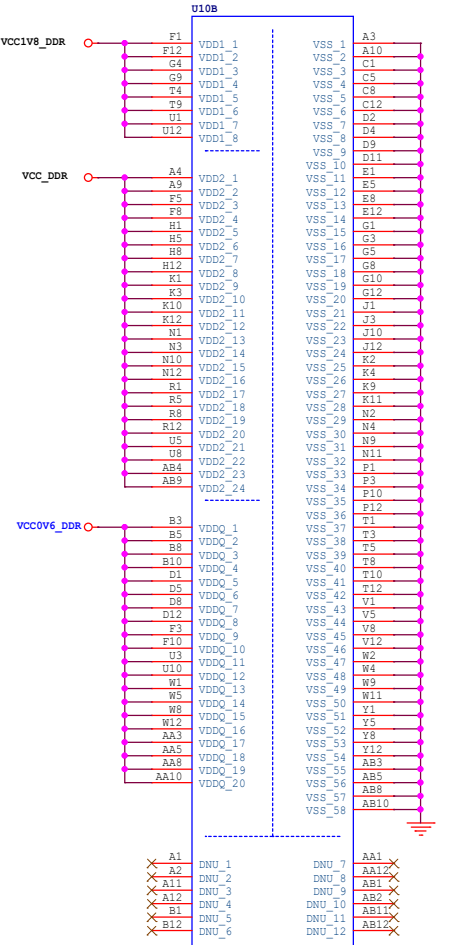
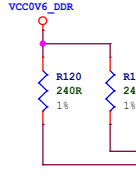
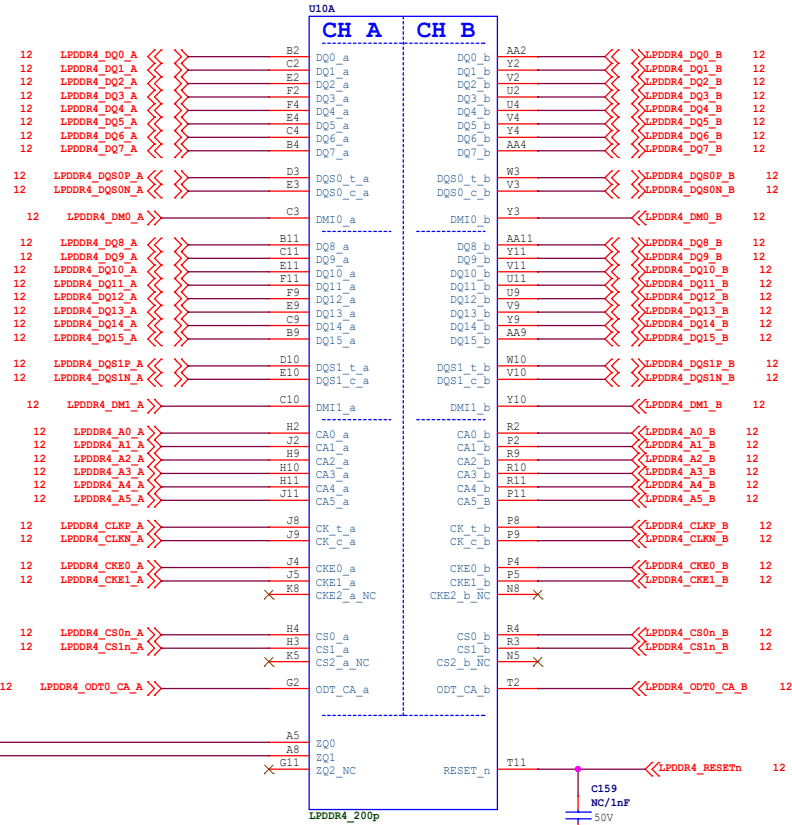

radxa

Size	Title: Zero 3W	REV
A4	Page Name: RK3566_Flash/SD	V1.11
Date: Thursday, September 21, 2023	Sheet 13	of 22





Size	Title: Zero 3W	REV
A3	Page Name: LPDDR4X_1X32bit	V1.11
Date: Thursday, September 21, 2023	Sheet 14	of 22

EMMC FLASH

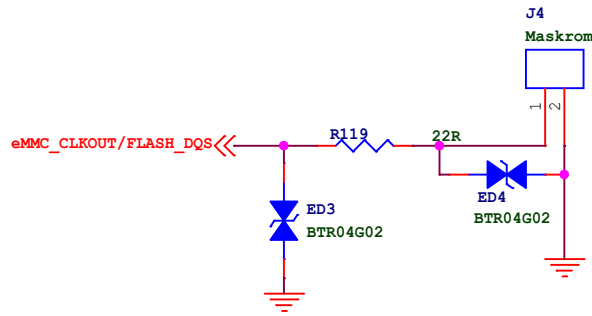
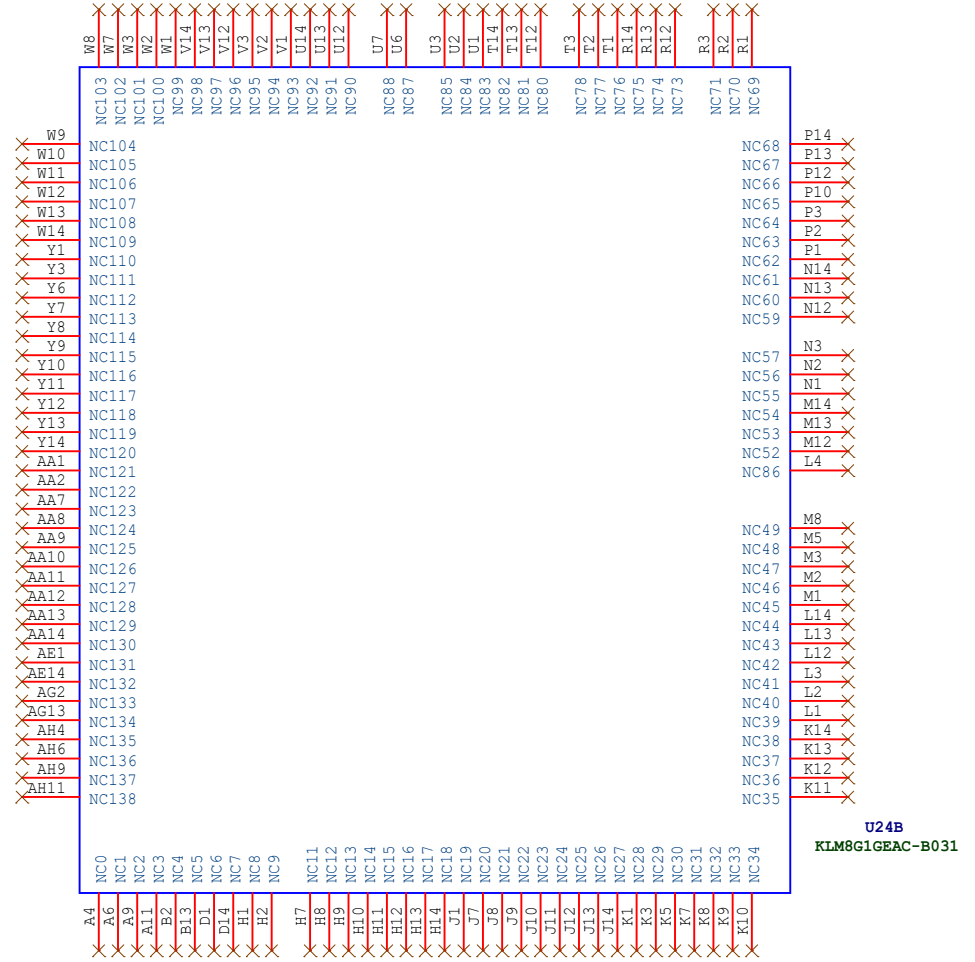
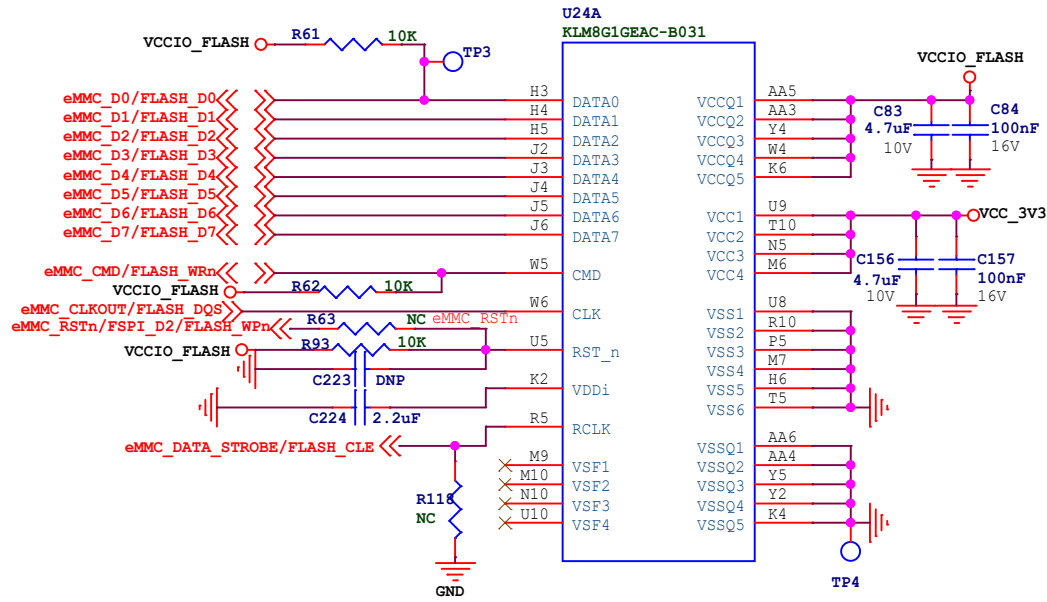

MicroSD Card

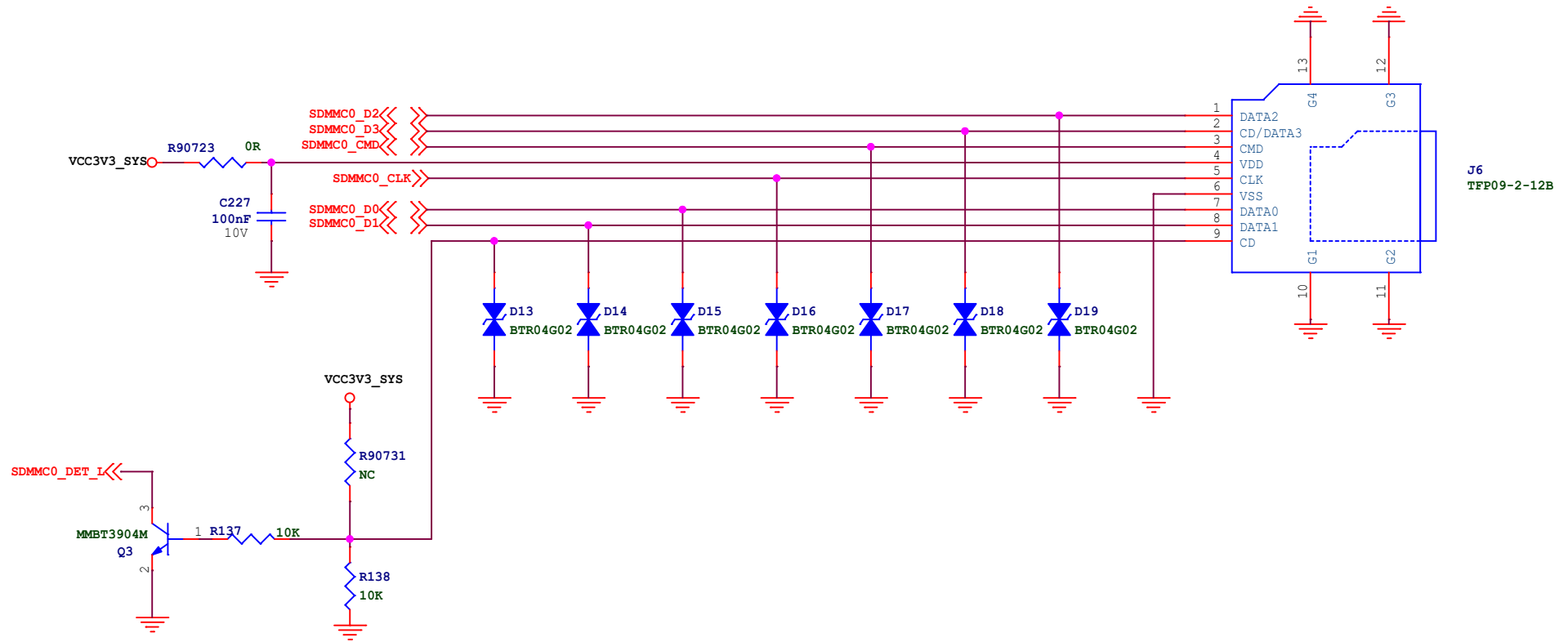

Size	Title: Zero 3W	REV
A4	Page Name: MicroSD Card	V1.11
Date: Thursday, September 21, 2023 Sheet 16 of 22		

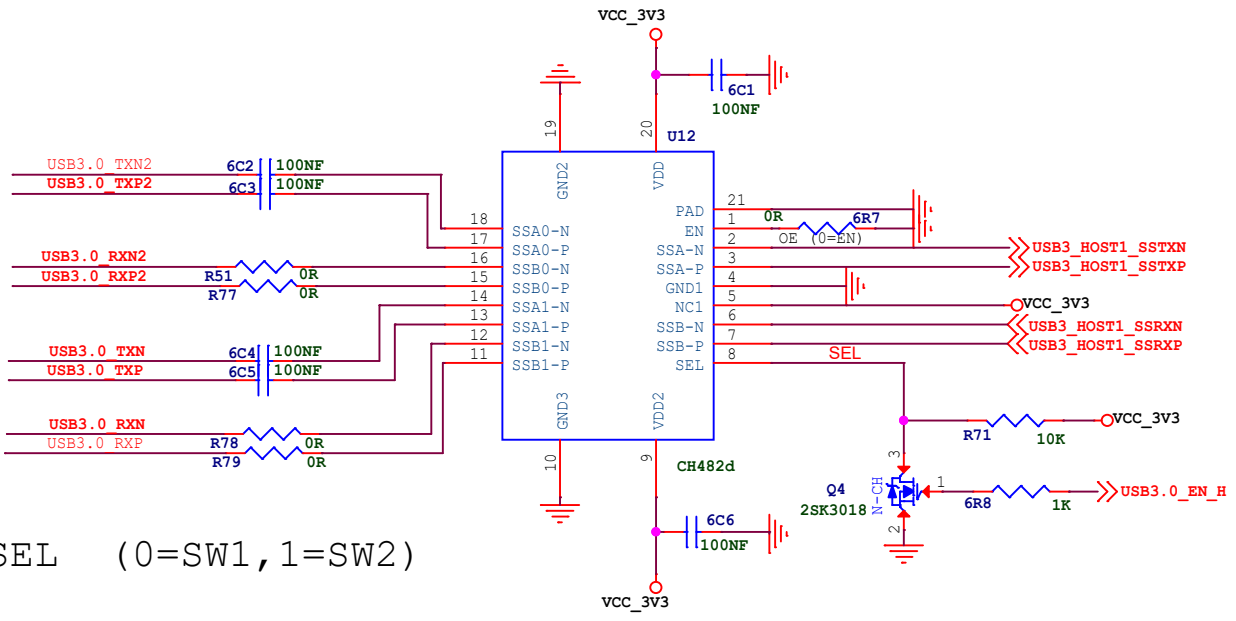
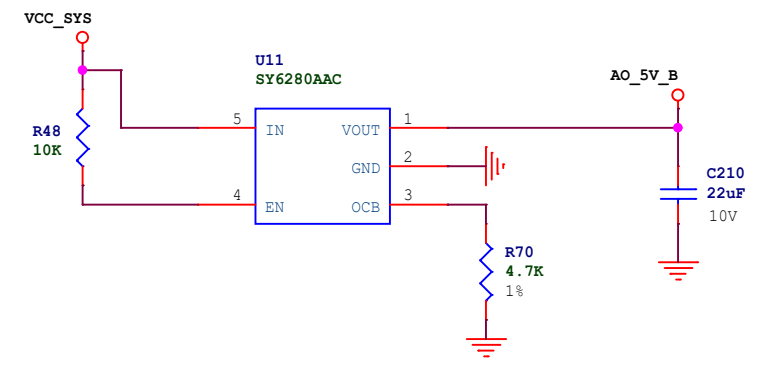
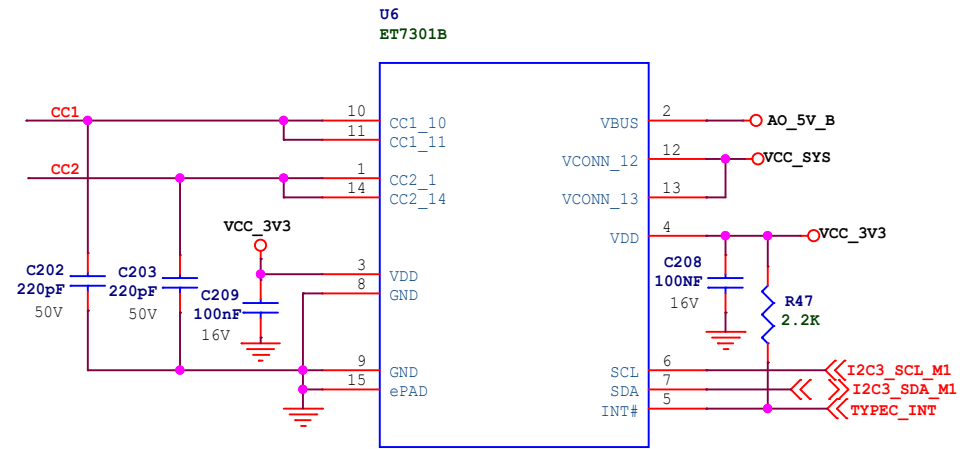
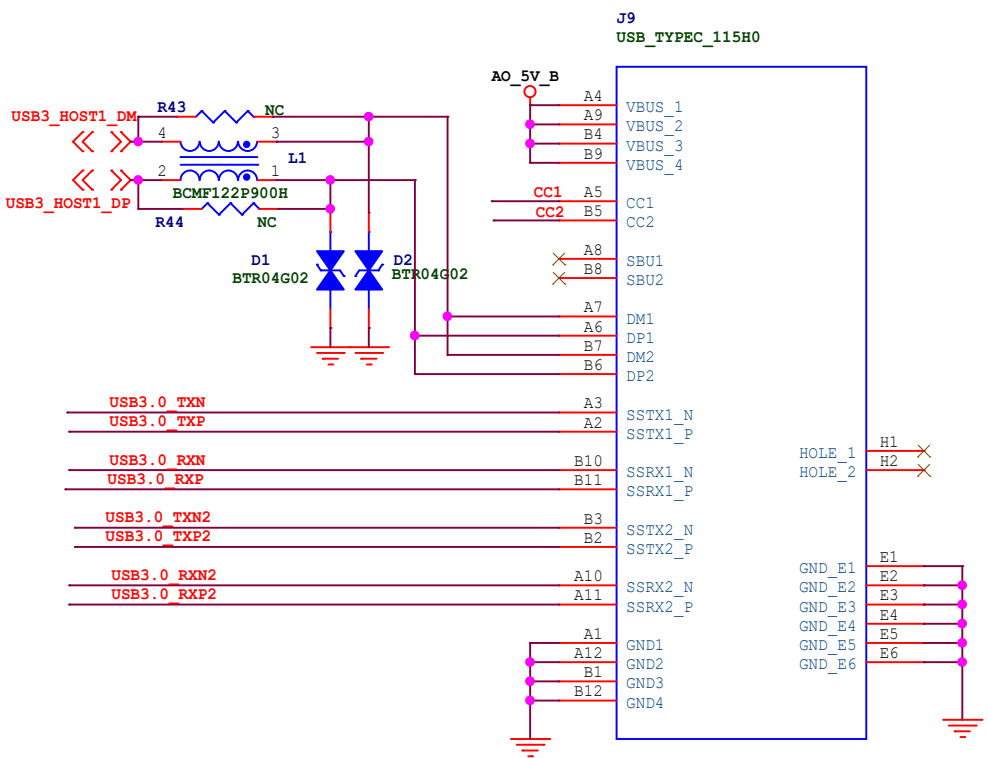

SEL (0=SW1, 1=SW2)



Size	Title: Zero 3W	REV
A4	Page Name: USB Port	V1.11
Date: Thursday, September 21, 2023	Sheet 17	of 22

>>>HDMI_TX2P_PORT
 >>>HDMI_TX2N_PORT
 >>>HDMI_TX1P_PORT
 >>>HDMI_TX1N_PORT
 >>>HDMI_TX0P_PORT
 >>>HDMI_TX0N_PORT
 >>>HDMI_TXCLKP_PORT
 >>>HDMI_TXCLKN_PORT

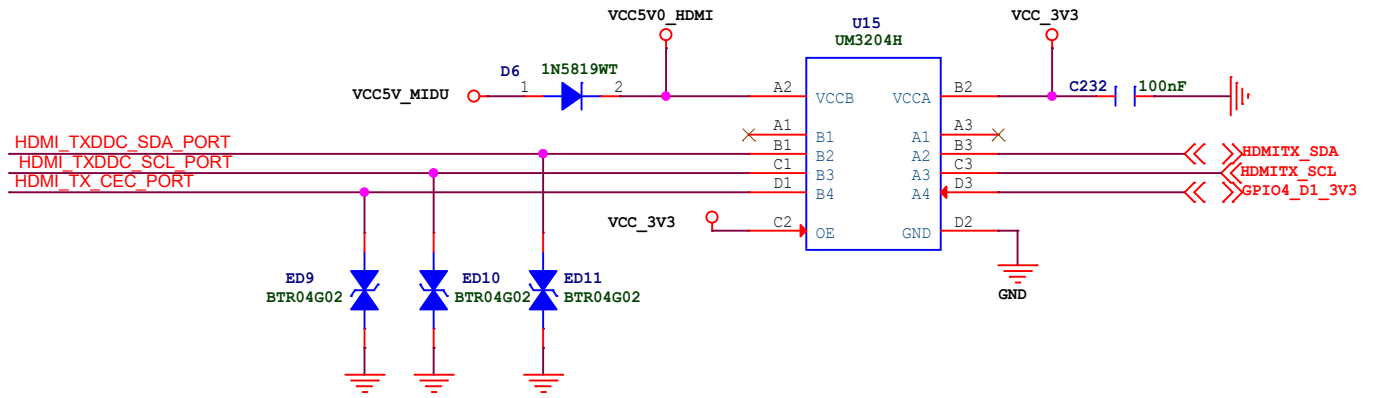

HDMI TX HPD

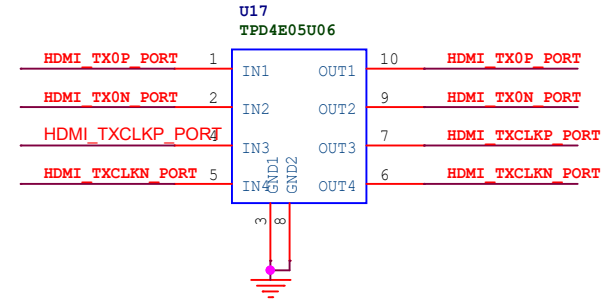
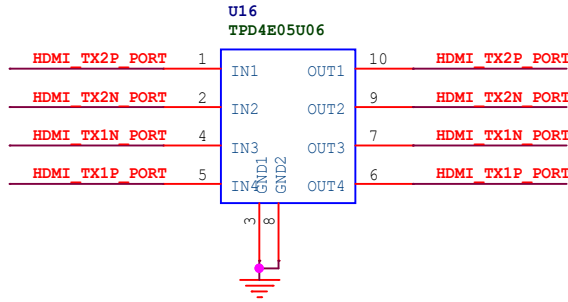
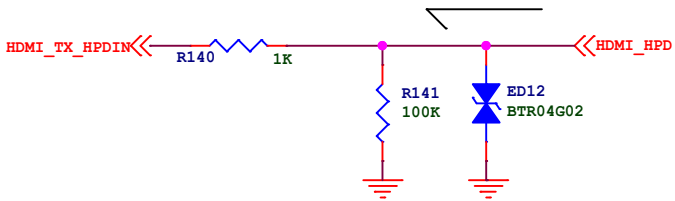

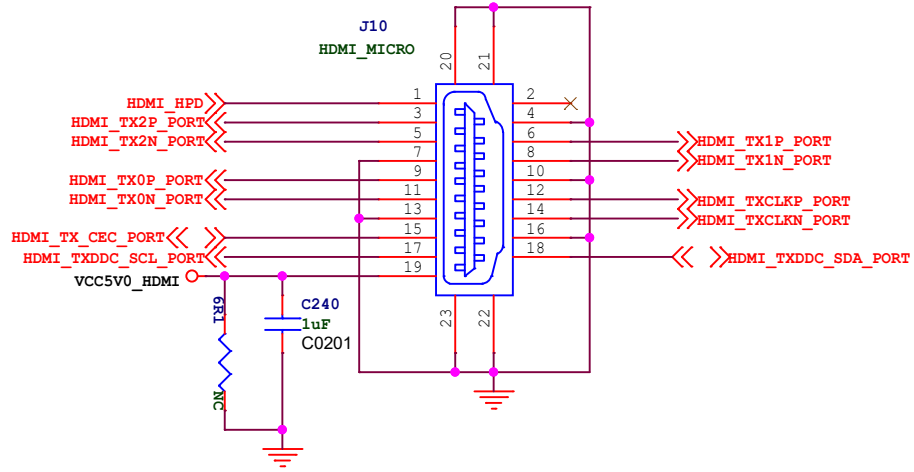

MICRO HDMI output

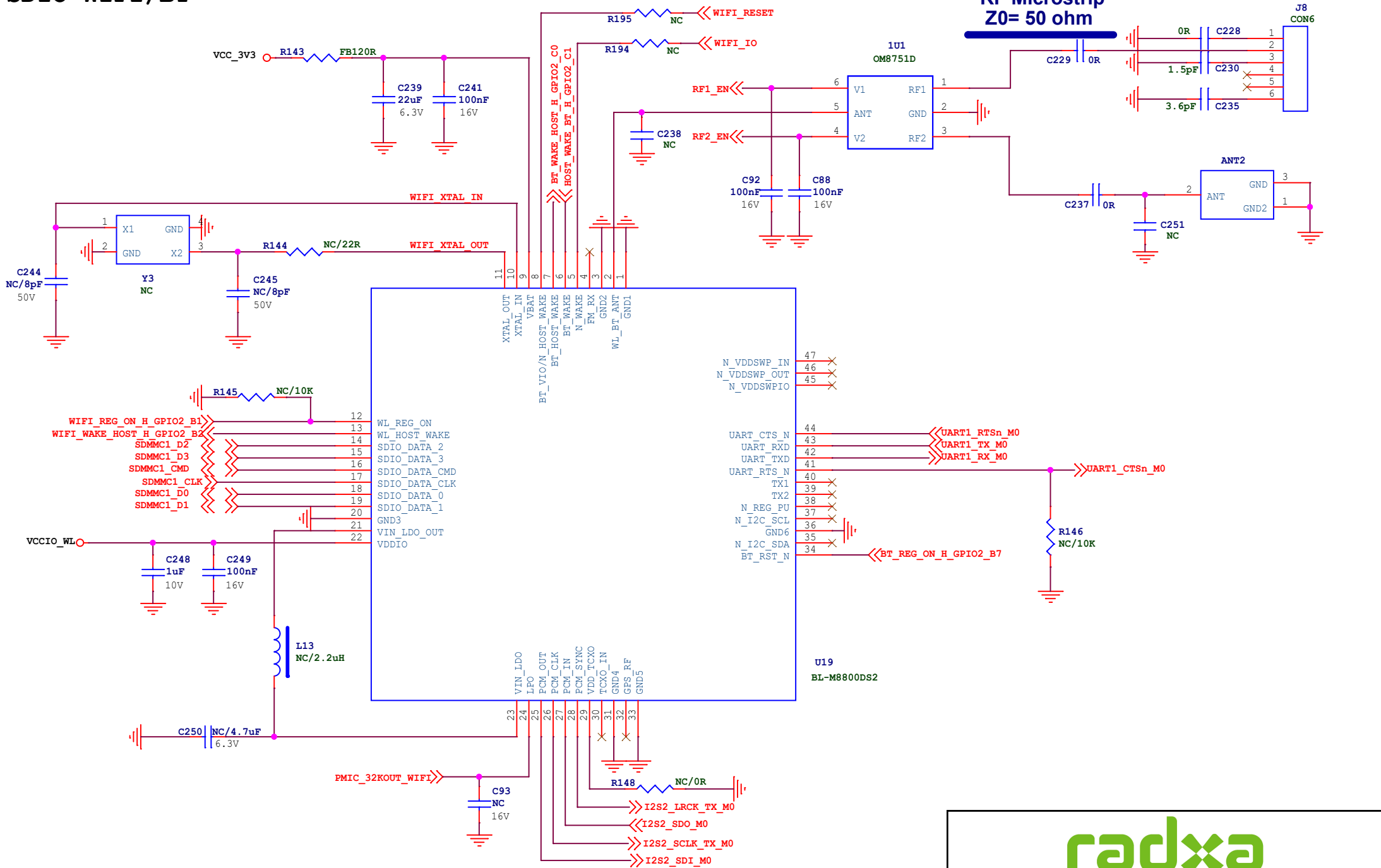

Size	Title:	Zero 3W
A4	Page Name:	HDMI2.0 TX
Date:	Thursday, September 21, 2023	Sheet 18 of 22
	REV	V1.11

SDIO WIFI/BT





Size	Title: Zero 3W	REV
A4	Page Name: WIFI/BT-SDIO	V1.11
Date:	Thursday, January 16, 2025	Sheet 19 of 22

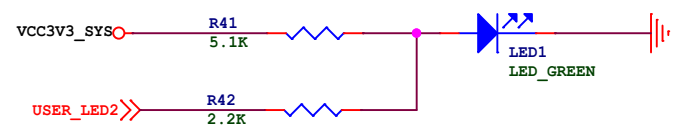
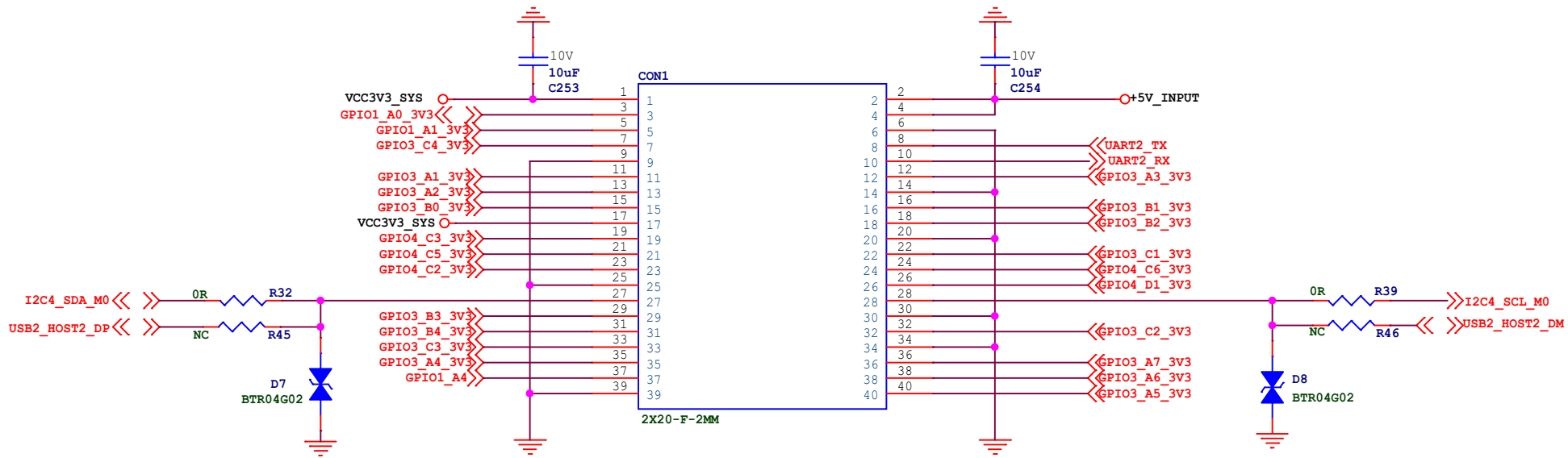



Size	Title: Zero 3W	REV
A4	Page Name: CONNECTOR	V1.11
Date: Thursday, September 21, 2023 Sheet 20 of 22		

PMIC RK817 DCDC

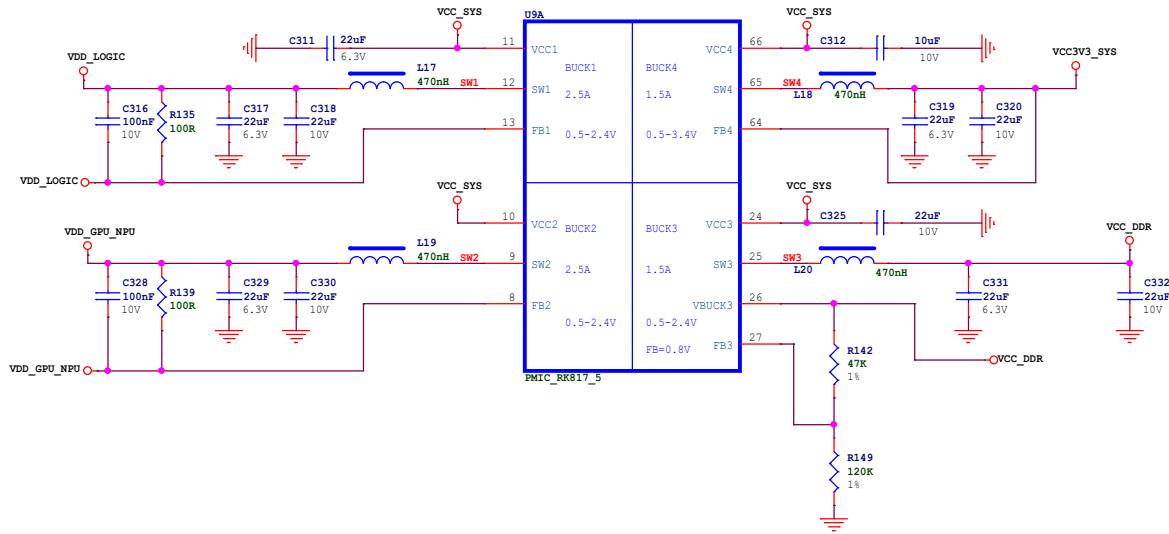

PMIC RK817 LDO

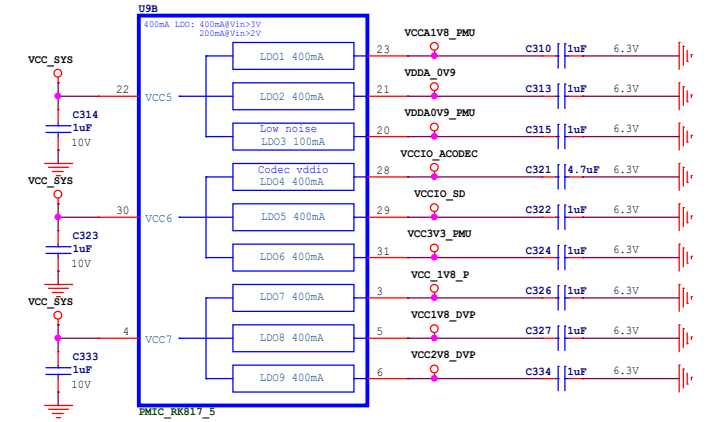

PMIC RK817 Management

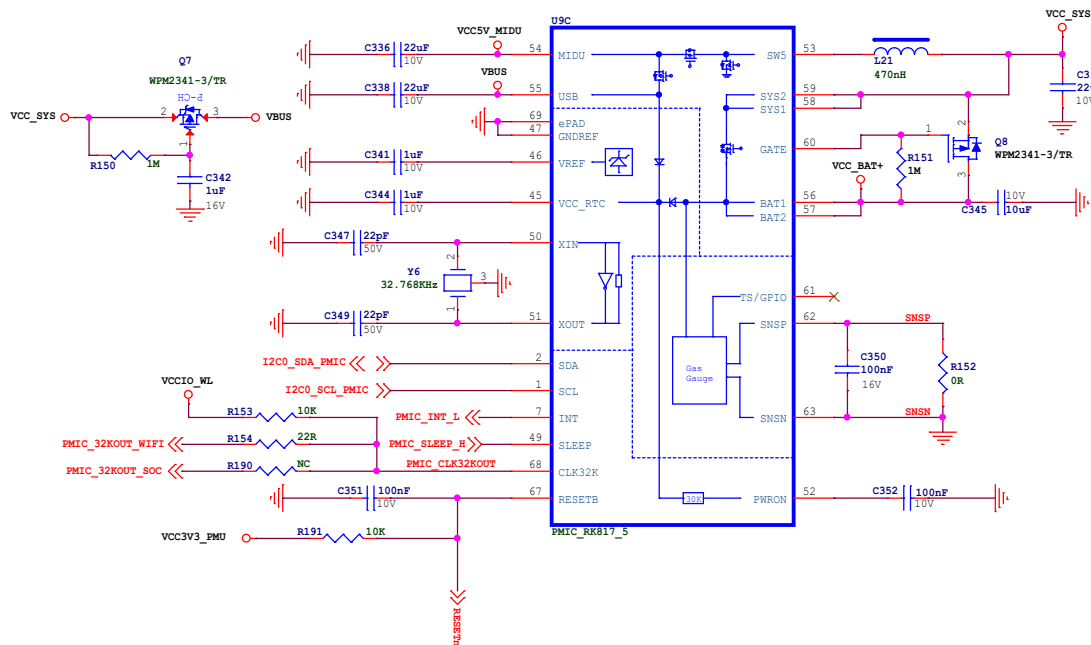

PMIC RK817 CODEC

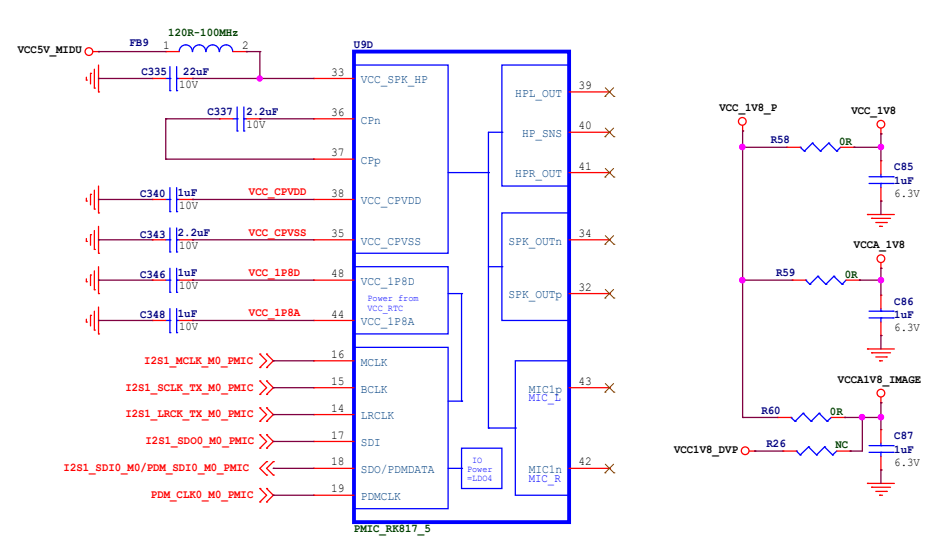

DC 5V IN

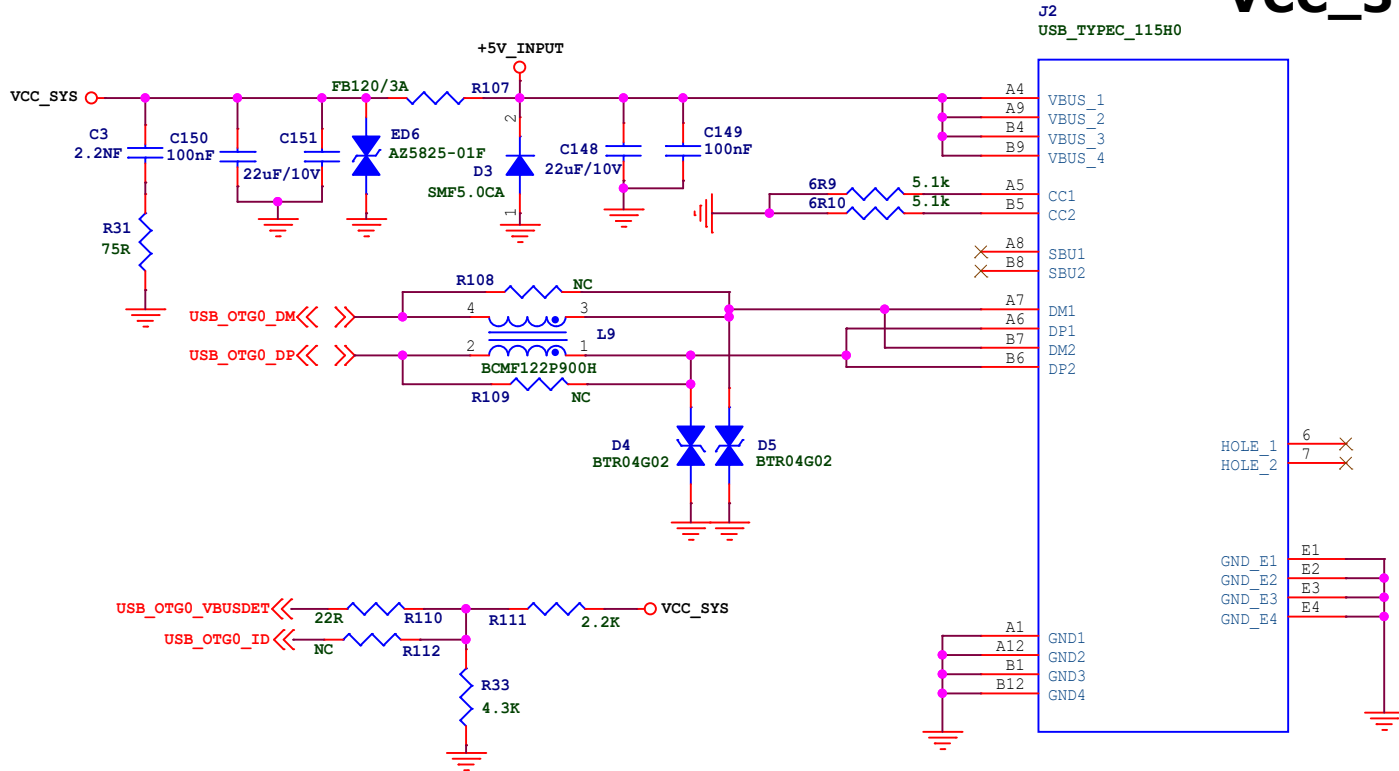

VCC_3V3 (Power OFF under SLEEP)

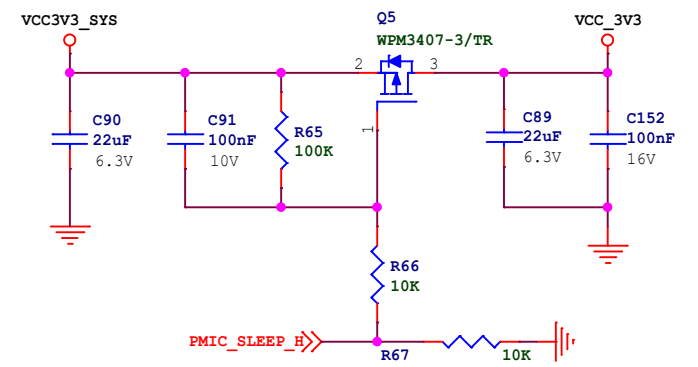

VDD_CPU_EXT

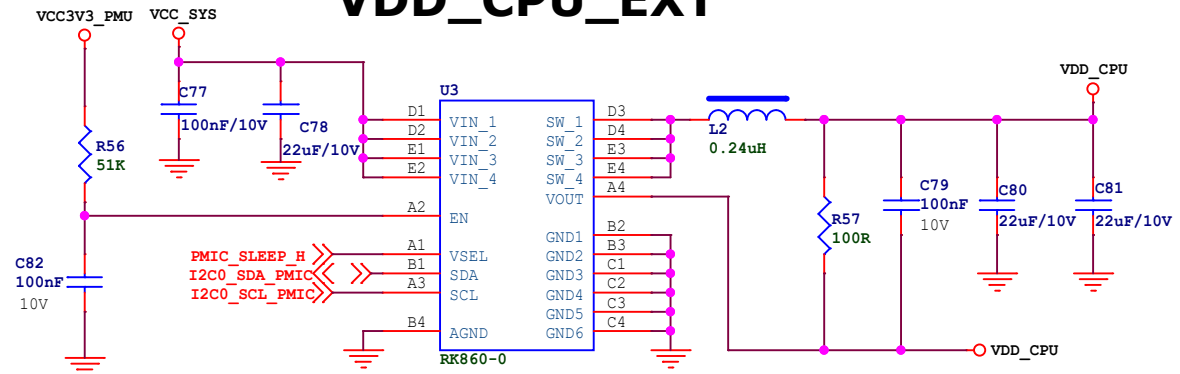

Size	Title:	Zero 3W	REV
A4	Page Name:	Power_DC IN	V1.11
Date:	Thursday, September 21, 2023	Sheet	22 of 22